

- 1. CONSTRUCTION            Red visual light emitting diodes featuring GaAsP packed with red diffused resin.
- 2. USAGE                    Power source for display unit.
- 3. DIMENSIONS            See Figure.1
- 4. ABSOLUTE MAXIMUM RATINGS (Ta=25°C)

|                       |       |       |                  |
|-----------------------|-------|-------|------------------|
| Power Dissipation     | P D   | ..... | 60mW             |
| Forward Current       | I F   | ..... | 20mA             |
| Peak Forward Current  | I F P | ..... | 60mA ( Notes 1 ) |
| Reverse Voltage       | V R   | ..... | 3V               |
| Operating Temperature | Topr  | ..... | -25°C ~ + 85°C   |
| Storage Temperature   | Tstg  | ..... | -30°C ~ +100°C   |

( Notes1 Duty 1/5 Pulse Width 1ms )

5. ELECTRO—OPTICAL CHARACTERISTICS ( Ta=25°C)

| DISCRIPTION              | SYMBOL | CONDITION | MIN. | TYP. | MAX. | UNITS |
|--------------------------|--------|-----------|------|------|------|-------|
| Forward Voltage          | VF     | IF=10mA   | —    | 2.0  | 3.0  | V     |
| Reverse Current          | IR     | VR=3V     | —    | —    | 10   | μ A   |
| Luminous Intensity       | IV     | IF=10mA   | 3.6  | 10   | (28) | mcd   |
| Peak Wave Length         | λP     | IF=10mA   | —    | 650  | —    | nm    |
| Spectral Line Half Width | Δλ     | IF=10mA   | —    | 40   | —    | nm    |

( ) : Reference

6. LUMINOUS CLASSIFICATION (Ta=25°C, IF=10mA)

| SYMBOL | LUMINOUS CLASSIFICATION RANGE |
|--------|-------------------------------|
| “K”    | 3.6 ~ 7.1 mcd                 |
| “L”    | 5.6 ~ 11 mcd                  |
| “M”    | 9.0 ~ 18 mcd                  |
| “N”    | 14 ~ (28) mcd                 |

( ) : Reference

Due to luminous intensity up, Intensity might shift.

- 7. PRODUCT WEIGHT        Product weight per piece, approx 0.12gm.

- 1. CONSTRUCTION                      Red visual light emitting diodes featuring GaAsP packed with transparent red-colored resin.
- 2. USAGE                                Power source for display unit.
- 3. DIMENSIONS                        See Figure.1
- 4. ABSOLUTE MAXIMUM RATINGS (Ta=25°C)

|                       |       |                                     |                  |
|-----------------------|-------|-------------------------------------|------------------|
| Power Dissipation     | P D   | .....                               | 60mW             |
| Forward Current       | I F   | .....                               | 20mA             |
| Peak Forward Current  | I F P | .....                               | 60mA ( Notes 1 ) |
| Reverse Voltage       | V R   | .....                               | 3V               |
| Operating Temperature | Topr  | .....                               | -25°C ~ + 85°C   |
| Storage Temperature   | Tstg  | .....                               | -30°C ~ +100°C   |
|                       |       | ( Notes1 Duty 1/5 Pulse Width 1ms ) |                  |

5. ELECTRO—OPTICAL CHARACTERISTICS ( Ta=25°C)

| DISCRIPTION              | SYMBOL | CONDITION | MIN. | TYP. | MAX. | UNITS |
|--------------------------|--------|-----------|------|------|------|-------|
| Forward Voltage          | VF     | IF=10mA   | —    | 2.0  | 3.0  | V     |
| Reverse Current          | IR     | VR=3V     | —    | —    | 10   | μ A   |
| Luminous Intensity       | IV     | IF=10mA   | 3.6  | 10   | (28) | mcd   |
| Peak Wave Length         | λ P    | IF=10mA   | —    | 650  | —    | nm    |
| Spectral Line Half Width | Δ λ    | IF=10mA   | —    | 40   | —    | nm    |

( ) : Reference

6. LUMINOUS CLASSIFICATION (Ta=25°C, IF=10mA)

| SYMBOL | LUMINOUS CLASSIFICATION RANGE |
|--------|-------------------------------|
| “K”    | 3.6 ~ 7.1 mcd                 |
| “L”    | 5.6 ~ 11 mcd                  |
| “M”    | 9.0 ~ 18 mcd                  |
| “N”    | 14 ~ (28) mcd                 |

( ) : Reference

Due to luminous intensity up, Intensity might shift.

- 7. PRODUCT WEIGHT                  Product weight per piece, approx 0.12gm.

- 1. CONSTRUCTION                      Orange visual light emitting diodes featuring GaAsP packed with orange diffused resin.
- 2. USAGE                                Power source for display unit.
- 3. DIMENSIONS                        See Figure.1
- 4. ABSOLUTE MAXIMUM RATINGS (Ta=25°C)

|                       |       |                                     |                  |
|-----------------------|-------|-------------------------------------|------------------|
| Power Dissipation     | P D   | .....                               | 60mW             |
| Forward Current       | I F   | .....                               | 20mA             |
| Peak Forward Current  | I F P | .....                               | 60mA ( Notes 1 ) |
| Reverse Voltage       | V R   | .....                               | 3V               |
| Operating Temperature | Topr  | .....                               | -25°C ~ + 85°C   |
| Storage Temperature   | Tstg  | .....                               | -30°C ~ +100°C   |
|                       |       | ( Notes1 Duty 1/5 Pulse Width 1ms ) |                  |

5. ELECTRO—OPTICAL CHARACTERISTICS ( Ta=25°C)

| DISCRIPTION              | SYMBOL | CONDITION | MIN. | TYP. | MAX. | UNITS |
|--------------------------|--------|-----------|------|------|------|-------|
| Forward Voltage          | VF     | IF=10mA   | —    | 2.0  | 3.0  | V     |
| Reverse Current          | IR     | VR=3V     | —    | —    | 10   | μ A   |
| Luminous Intensity       | IV     | IF=10mA   | 3.6  | 10   | (28) | mcd   |
| Peak Wave Length         | λ P    | IF=10mA   | —    | 610  | —    | nm    |
| Spectral Line Half Width | Δ λ    | IF=10mA   | —    | 40   | —    | nm    |

( ) : Reference

6. LUMINOUS CLASSIFICATION (Ta=25°C, IF=10mA)

| SYMBOL | LUMINOUS CLASSIFICATION RANGE |
|--------|-------------------------------|
| “K”    | 3.6 ~ 7.1 mcd                 |
| “L”    | 5.6 ~ 11 mcd                  |
| “M”    | 9.0 ~ 18 mcd                  |
| “N”    | 14 ~ (28) mcd                 |

( ) : Reference

Due to luminous intensity up, Intensity might shift.

- 7. PRODUCT WEIGHT                  Product weight per piece, approx 0.12gm.

- 1. CONSTRUCTION                      Orange visual light emitting diodes featuring GaAsP packed with transparent orange-colored resin.
- 2. USAGE                                Power source for display unit.
- 3. DIMENSIONS                        See Figure.1
- 4. ABSOLUTE MAXIMUM RATINGS (Ta=25°C)

|                       |       |                                     |                  |
|-----------------------|-------|-------------------------------------|------------------|
| Power Dissipation     | P D   | .....                               | 60mW             |
| Forward Current       | I F   | .....                               | 20mA             |
| Peak Forward Current  | I F P | .....                               | 60mA ( Notes 1 ) |
| Reverse Voltage       | V R   | .....                               | 3V               |
| Operating Temperature | Topr  | .....                               | -25°C ~ + 85°C   |
| Storage Temperature   | Tstg  | .....                               | -30°C ~ +100°C   |
|                       |       | ( Notes1 Duty 1/5 Pulse Width 1ms ) |                  |

5. ELECTRO—OPTICAL CHARACTERISTICS ( Ta=25°C)

| DISCRIPTION              | SYMBOL | CONDITION | MIN. | TYP. | MAX. | UNITS |
|--------------------------|--------|-----------|------|------|------|-------|
| Forward Voltage          | VF     | IF=10mA   | —    | 2.0  | 3.0  | V     |
| Reverse Current          | IR     | VR=3V     | —    | —    | 10   | μ A   |
| Luminous Intensity       | IV     | IF=10mA   | 5.6  | 16   | (45) | mcd   |
| Peak Wave Length         | λ P    | IF=10mA   | —    | 610  | —    | nm    |
| Spectral Line Half Width | Δ λ    | IF=10mA   | —    | 40   | —    | nm    |

( ) : Reference

6. LUMINOUS CLASSIFICATION (Ta=25°C, IF=10mA)

| SYMBOL | LUMINOUS CLASSIFICATION RANGE |
|--------|-------------------------------|
| “L”    | 5.6 ~ 11 mcd                  |
| “M”    | 9.0 ~ 18 mcd                  |
| “N”    | 14 ~ 28 mcd                   |
| “P”    | 22 ~ (45) mcd                 |

( ) : Reference

Due to luminous intensity up, Intensity might shift.

- 7. PRODUCT WEIGHT                  Product weight per piece, approx 0.12gm.

- 1. CONSTRUCTION                      Yellow visual light emitting diodes featuring GaAsP packed with transparent yellow-colored resin.
- 2. USAGE                                Power source for display unit.
- 3. DIMENSIONS                        See Figure.1
- 4. ABSOLUTE MAXIMUM RATINGS (Ta=25°C)

|                       |       |       |                  |
|-----------------------|-------|-------|------------------|
| Power Dissipation     | P D   | ..... | 60mW             |
| Forward Current       | I F   | ..... | 20mA             |
| Peak Forward Current  | I F P | ..... | 60mA ( Notes 1 ) |
| Reverse Voltage       | V R   | ..... | 3V               |
| Operating Temperature | Topr  | ..... | -25°C ~ + 85°C   |
| Storage Temperature   | Tstg  | ..... | -30°C ~ +100°C   |

( Notes1 Duty 1/5 Pulse Width 1ms )

5. ELECTRO—OPTICAL CHARACTERISTICS ( Ta=25°C)

| DISCRIPTION              | SYMBOL | CONDITION | MIN. | TYP. | MAX. | UNITS |
|--------------------------|--------|-----------|------|------|------|-------|
| Forward Voltage          | VF     | IF=10mA   | —    | 2.1  | 3.0  | V     |
| Reverse Current          | IR     | VR=3V     | —    | —    | 10   | μ A   |
| Luminous Intensity       | IV     | IF=10mA   | 3.6  | 10   | (28) | mcd   |
| Peak Wave Length         | λ P    | IF=10mA   | —    | 585  | —    | nm    |
| Spectral Line Half Width | Δ λ    | IF=10mA   | —    | 40   | —    | nm    |

( ) : Reference

6. LUMINOUS CLASSIFICATION (Ta=25°C, IF=10mA)

| SYMBOL | LUMINOUS CLASSIFICATION RANGE |
|--------|-------------------------------|
| “K”    | 3.6 ~ 7.1 mcd                 |
| “L”    | 5.6 ~ 11 mcd                  |
| “M”    | 9.0 ~ 18 mcd                  |
| “N”    | 14 ~ (28) mcd                 |

( ) : Reference

Due to luminous intensity up, Intensity might shift.

- 7. PRODUCT WEIGHT                  Product weight per piece, approx 0.12gm.

- 1. CONSTRUCTION                      Yellow Green visual light emitting diodes featuring GaP packed with green diffused resin.
- 2. USAGE                                Power source for display unit.
- 3. DIMENSIONS                        See Figure.1
- 4. ABSOLUTE MAXIMUM RATINGS (Ta=25°C)

|                       |       |                  |
|-----------------------|-------|------------------|
| Power Dissipation     | P D   | 75mW             |
| Forward Current       | I F   | 25mA             |
| Peak Forward Current  | I F P | 60mA ( Notes 1 ) |
| Reverse Voltage       | V R   | 3V               |
| Operating Temperature | Topr  | -25°C ~ + 85°C   |
| Storage Temperature   | Tstg  | -30°C ~ +100°C   |

( Notes1 Duty 1/5 Pulse Width 1ms )

5. ELECTRO—OPTICAL CHARACTERISTICS ( Ta=25°C)

| DISCRIPTION              | SYMBOL | CONDITION | MIN. | TYP. | MAX. | UNITS |
|--------------------------|--------|-----------|------|------|------|-------|
| Forward Voltage          | VF     | IF=10mA   | —    | 2.1  | 3.0  | V     |
| Reverse Current          | IR     | VR=3V     | —    | —    | 10   | μ A   |
| Luminous Intensity       | IV     | IF=10mA   | 5.6  | 16   | (45) | mcd   |
| Peak Wave Length         | λ P    | IF=10mA   | —    | 563  | —    | nm    |
| Spectral Line Half Width | Δ λ    | IF=10mA   | —    | 40   | —    | nm    |

( ) : Reference

6. LUMINOUS CLASSIFICATION (Ta=25°C, IF=10mA)

| SYMBOL | LUMINOUS CLASSIFICATION RANGE |
|--------|-------------------------------|
| “L”    | 5.6 ~ 11 mcd                  |
| “M”    | 9.0 ~ 18 mcd                  |
| “N”    | 14 ~ 28 mcd                   |
| “P”    | 22 ~ (45) mcd                 |

( ) : Reference

Due to luminous intensity up, Intensity might shift.

- 7. PRODUCT WEIGHT                      Product weight per piece, approx 0.12gm.

1. CONSTRUCTION Yellow Green visual light emitting diodes featuring GaP packed with transparent green-colored resin.

2. USAGE Power source for display unit.

3. DIMENSIONS See Figure.1

4. ABSOLUTE MAXIMUM RATINGS (Ta=25°C)

|                       |       |                  |
|-----------------------|-------|------------------|
| Power Dissipation     | P D   | 75mW             |
| Forward Current       | I F   | 25mA             |
| Peak Forward Current  | I F P | 60mA ( Notes 1 ) |
| Reverse Voltage       | V R   | 3V               |
| Operating Temperature | Topr  | -25°C ~ + 85°C   |
| Storage Temperature   | Tstg  | -30°C ~ +100°C   |

( Notes1 Duty 1/5 Pulse Width 1ms )

5. ELECTRO—OPTICAL CHARACTERISTICS ( Ta=25°C)

| DISCRIPTION              | SYMBOL | CONDITION | MIN. | TYP. | MAX. | UNITS |
|--------------------------|--------|-----------|------|------|------|-------|
| Forward Voltage          | VF     | IF=10mA   | —    | 2.1  | 3.0  | V     |
| Reverse Current          | IR     | VR=3V     | —    | —    | 10   | μ A   |
| Luminous Intensity       | IV     | IF=10mA   | 5.6  | 16   | (45) | mcd   |
| Peak Wave Length         | λ P    | IF=10mA   | —    | 563  | —    | nm    |
| Spectral Line Half Width | Δ λ    | IF=10mA   | —    | 40   | —    | nm    |

( ) : Reference

6. LUMINOUS CLASSIFICATION (Ta=25°C, IF=10mA)

| SYMBOL | LUMINOUS CLASSIFICATION RANGE |
|--------|-------------------------------|
| “L”    | 5.6 ~ 11 mcd                  |
| “M”    | 9.0 ~ 18 mcd                  |
| “N”    | 1.4 ~ 2.8 mcd                 |
| “P”    | 2.2 ~ (4.5) mcd               |

( ) : Reference

Due to luminous intensity up, Intensity might shift.

7. PRODUCT WEIGHT Product weight per piece, approx 0.12gram.

**【Figure.1 DIMENSIONS(Bulk drawing)】**

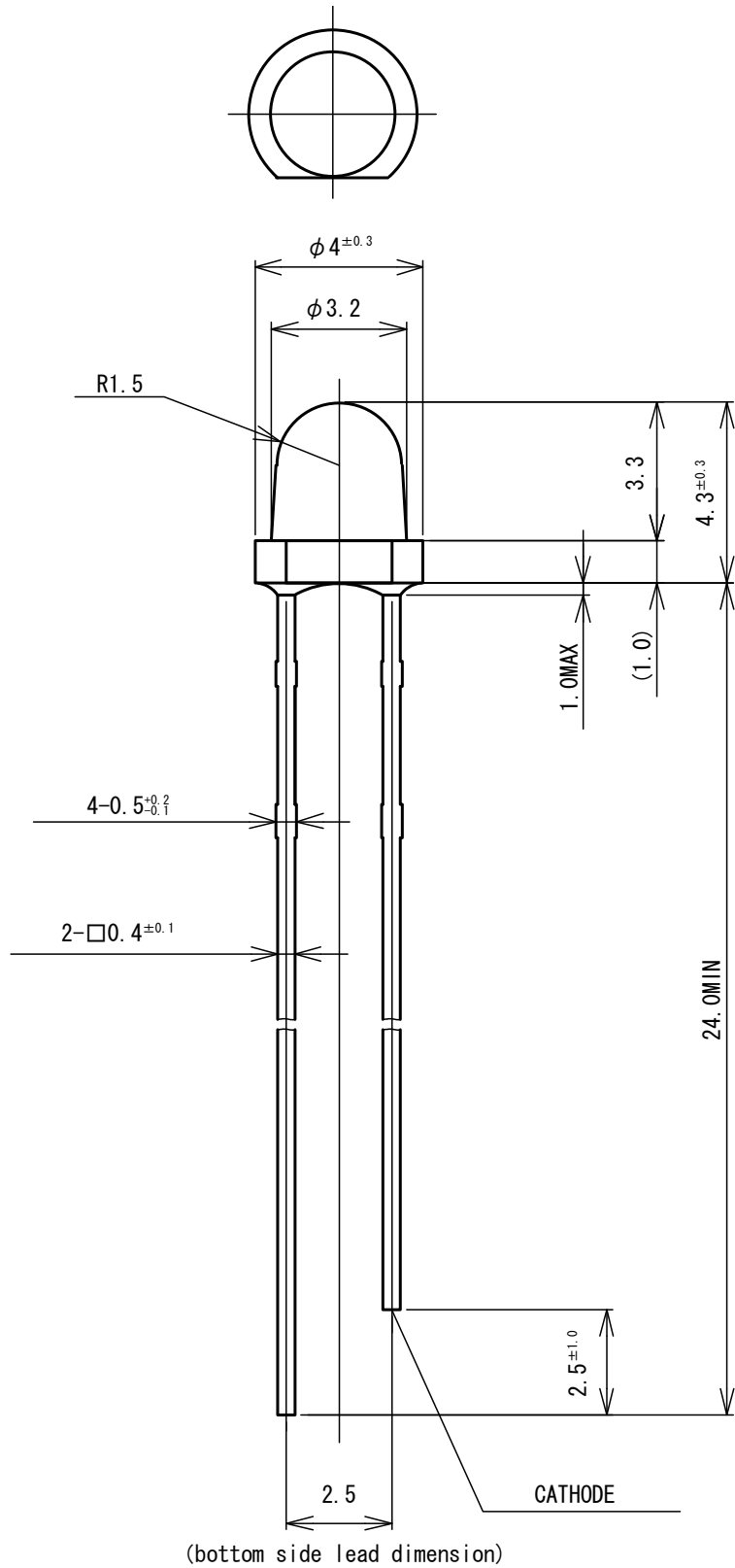

**【Taping : T32】**

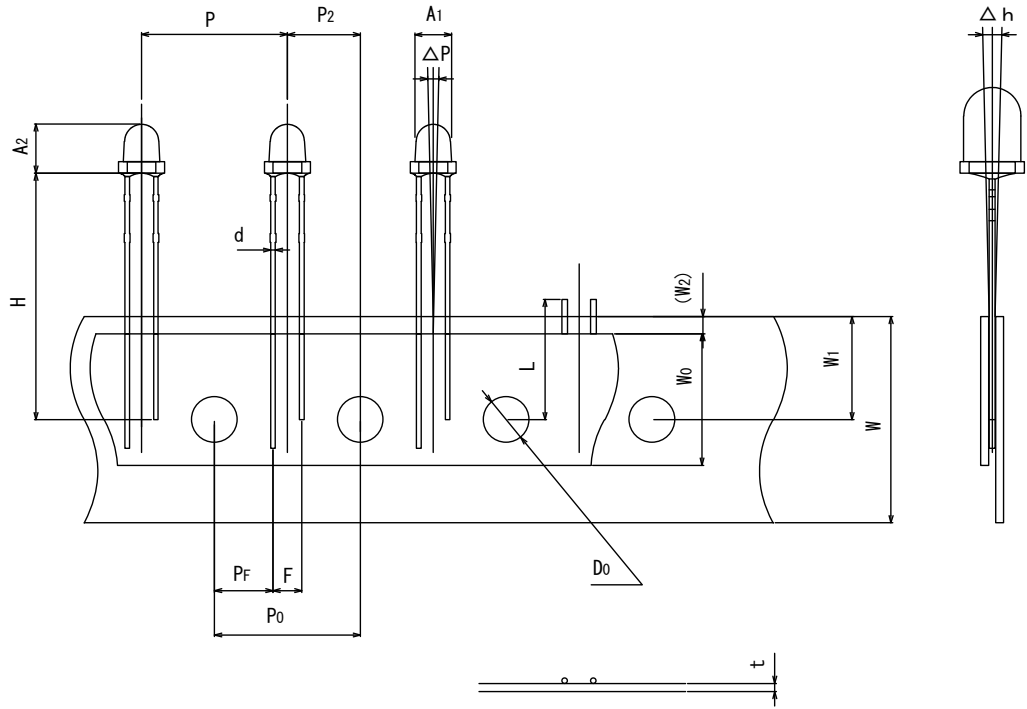

| ITEM                              | SYMBOL     | SPECIFICATION (Unit : mm)       |
|-----------------------------------|------------|---------------------------------|
| Body diameter                     | A1         | $\phi 3.2 \pm 0.2$              |
| Body height                       | A2         | $4.3 \pm 0.3$                   |
| Pitch of component                | P          | $12.7 \pm 1.0$                  |
| Feed hole pitch                   | P0         | $12.7 \pm 0.3$                  |
| Hole center to component center   | P2         | $6.35 \pm 0.4$                  |
| Hole pitch tolerance accumulation | P20        | For 20 pitches 1.0MAX           |
| Lead wire thickness               | d          | $\square 0.4 \pm 0.1$ ※         |
| Lead to lead distance             | F          | $2.5 \pm 0.8$                   |
| Clinch height                     | H          | $21.5 \pm 1.0$                  |
| Tape width                        | W          | $18.0^{+1.0}_{-0.5}$            |
| Hold down tape width              | W0         | $13.0 \pm 0.3$ , $10.0 \pm 0.3$ |
| Hole position                     | W1         | $9.0 \pm 0.5$                   |
| Hole down tape position           | W2         | 3.0MAX                          |
| Tape thickness                    | t          | $0.7 \pm 0.2$                   |
| Component alignment (1)           | $\Delta h$ | $0 \pm 2.0$                     |
| Component alignment (2)           | $\Delta P$ | $0 \pm 1.0$                     |
| Length of snapped lead            | L          | 11.0MAX                         |
| Feed hole center to lead center   | PF         | $5.1 \pm 0.8$                   |
| Feed hole diameter                | D0         | $\phi 4.0 \pm 0.2$              |

※Except flush

**【STRUCTURE・MATERIAL】**

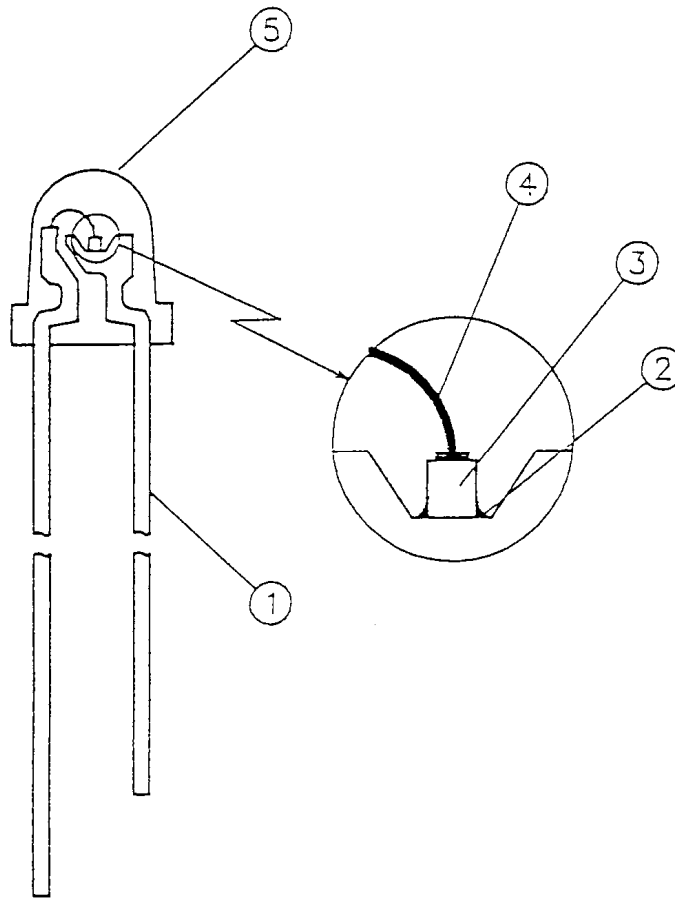

| No. | APPELLATION        | MATERIAL                                   |
|-----|--------------------|--|
| ①   | Lead Frame<br>Lead | Iron Copper + Silver Plating<br>Solder Dip |
| ②   | Die Bond           | Ag Paste                                   |
| ③   | LED Chip           | M, P : GaP<br>V, D, Y : GaAsP              |
| ④   | Bonding Wire       | Gold                                       |
| ⑤   | Resin              | Epoxy Resin                                |

**【PACKAGING REQUIREMENTS】**1.PACKGING

- 1.1 The tape is folded over across a pitch of 25 pieces or 26 pieces.
- 1.2 Tape leader and tape end leave 10 blank part positions.
- 1.3 Any reject units are clipped or cut off in the permissible location specified in the drawing.
- 1.4 No more than three consecutive blank and 10 pieces out of consecutive 1,000 pieces are permitted. However.

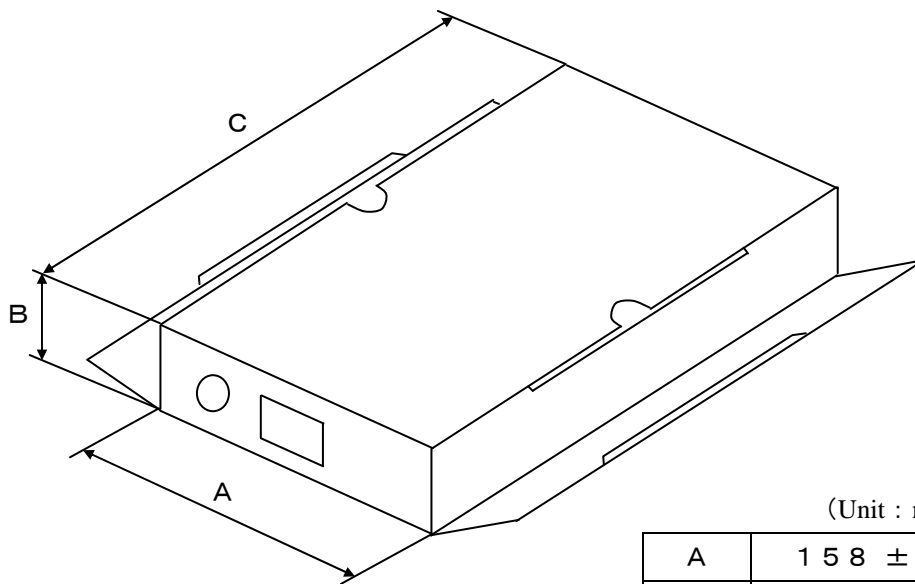
2.CARTON

(Unit : mm)

|   |         |
|---|---------|
| A | 158 ± 7 |
| B | 48 ± 7  |
| C | 340 ± 7 |

3.QUANTITY

2,000pcs/Box

4.TAPE TRAVEL INDICATION

Indication "C" on the four points where cathode lead leaves tape first,  
and indication "A" on the four points where anode lead leaves tape first.

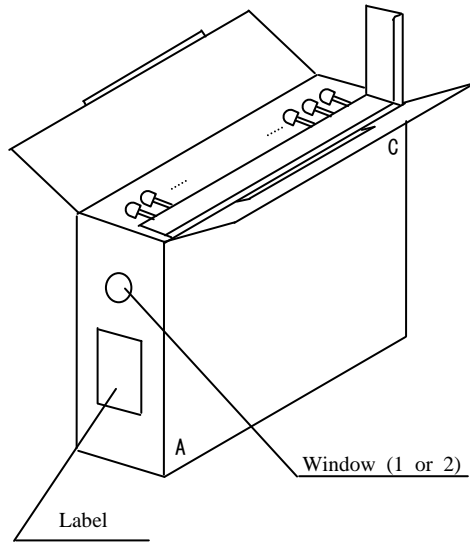

5.TAPE DEVICE RETENTION PARAMETERS

5.1 Horizontal direction

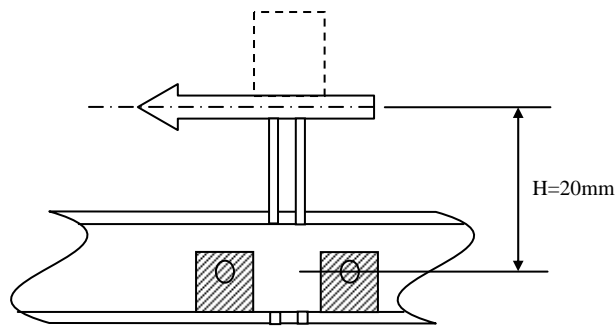

Stable  
F=1N {round 102gf} Applied for  $3 \pm 1$ sec

5.2 Vertical direction

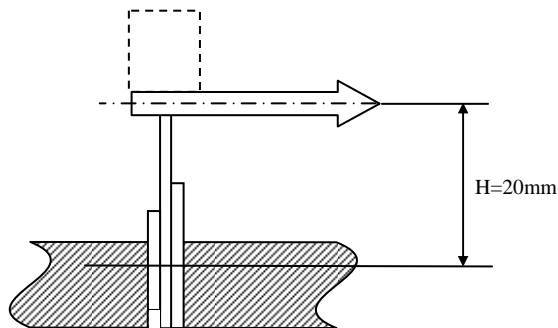

Stable  
F=0.7N {round 71.4gf} Applied for  $3 \pm 1$ sec

5.3 Adhesiveness

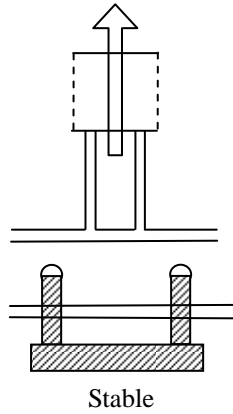

• More than 5N {round 510gf}  
Lead should not come off or  
be misaligned.

Force on to arrow direction.

6. ANNEX

6.1 No more three consecutive blank space permitted.

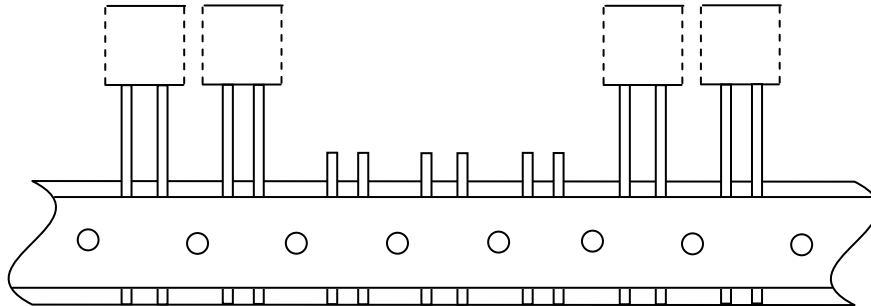

6.2 Tape jointing, in case of tape end or cutting, is done with jointing tape or sticky tape.  
The jointing area's thickness is 1.5mm max and strength is more than 10N {round 1.02kgf}.

6.3 Permissible misalignment is 1.0mm max across a pitch of 20 holes.

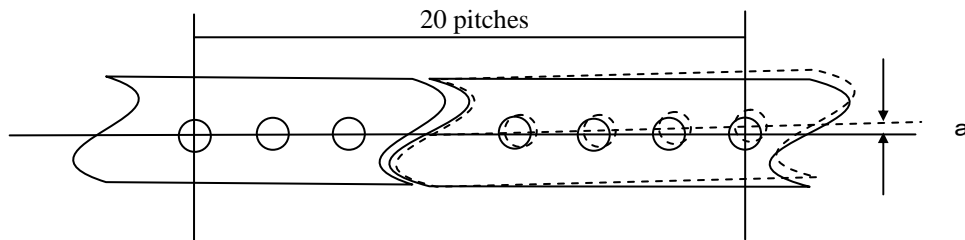

2.MARKING

The following information shall be described on a box label:  
ROHM type number, packaging quantity, luminous intensity rank, lot number etc.

【FORMER LABEL SPECIFICATION】

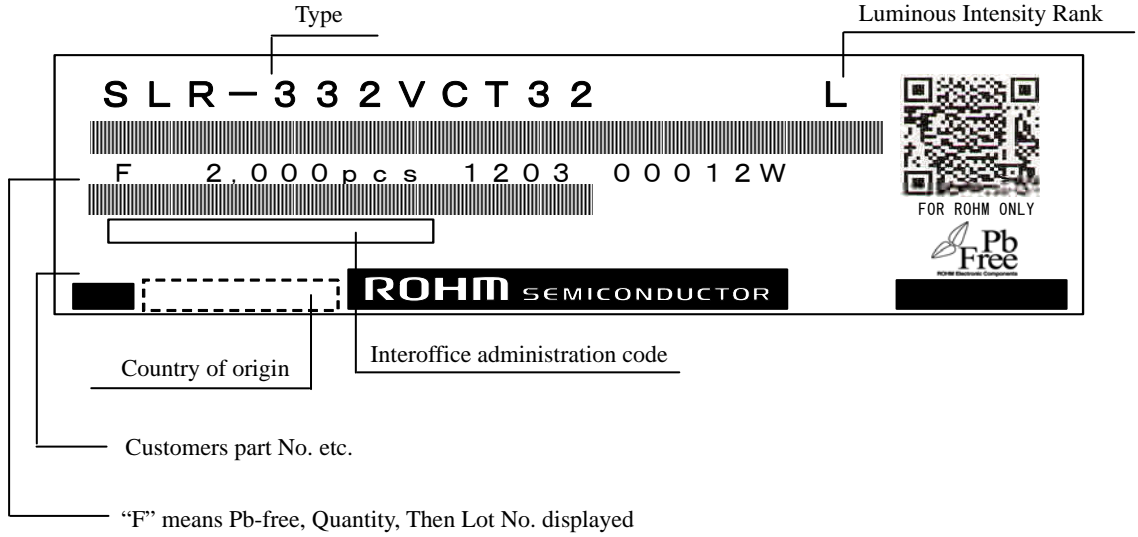

NOTE) Indicates bar code expressed by code 39

indicates Pb-free Products.

【EXAMPLE OF LOT NO. MARKING】

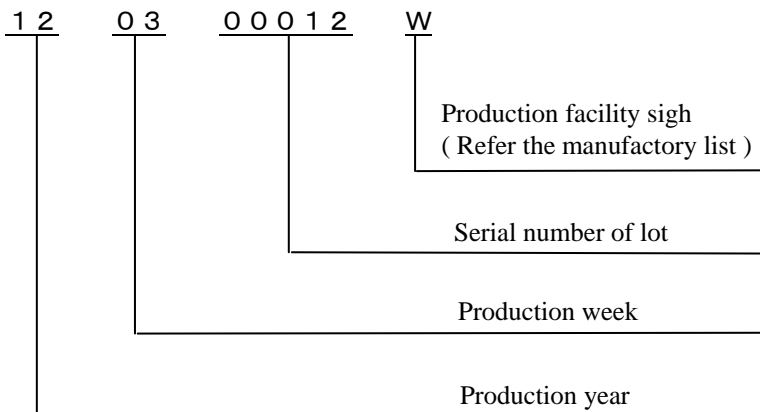

**【ATTENTION POINTS IN HANDLING】**

Visual light emitting diode does not contain reinforcement materials such as glass fillers.  
Therefore if sudden thermal and mechanical shock are given, destruction or inferiority of luminous intensity may occur. Please take care of the handling.

■ FIXATION METHOD

1. ATTENTION POINTS

- (1) Please do not give excessive heat over storage temperature to resin.  
In case that the product has to be heated in oven for the glue fixing of surface mount pads, this LED should be mounted after the glue fixing.
- (2) Please avoid stress to resin at high temperature.

2. TERMINATION PROCESSING

- (1) In case of termination processing, please fix the termination
- (2) Processing position, and process the reverse side of LED body.  
If stress is given during processing, It may cause non-lighting failure.
- (3) Please process before soldering.

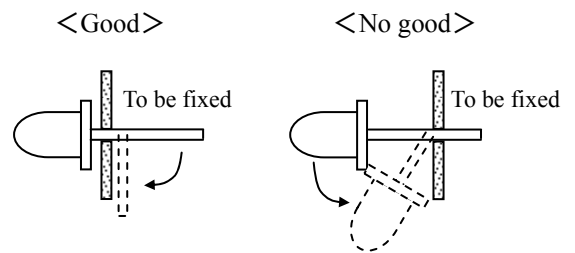

3. ASSEMBLY ON PC BOARD

- (1) In case of soldering on PCB, If the operation is done with stress, it may cause non-lighting failure during soldering or using.  
Please design the through-holes of PCB suitable for lead pins space or lead pins space after forming to avoid the physical stress on resin.

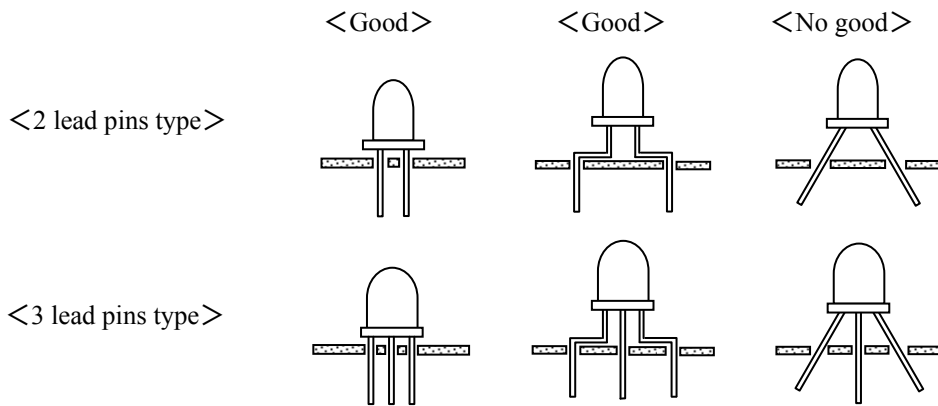

- (2) Using spacer between LED's body and PCB is recommended.  
In case of direct mount on PCB(SLR/SLI-343 series), please take care about clinch of led pins to avoid the remained stress and solder heat stress.  
Enough evaluation is requested before deciding assembly and soldering conditions.  
Please consult with us if any problems in the evaluation stage.

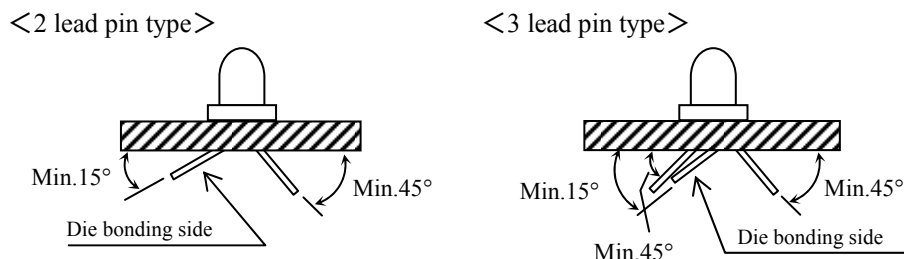

4. SOLDERING (Sn-3Ag-0.5Cu)

- (1) Please make soldering rapidly under the following temperature and time conditions.
- (2) Please avoid stress to LED lamp during soldering.
- (3) In case of double peak flow soldering, the temperature gap during 1<sup>st</sup> and 2<sup>nd</sup> soldering to be less than 100 degree C.

<Recommendable soldering conditions>

| ARTICLE        | SOLDERING TEMP | OPERATION TIME | Remarks                                   |   |
|----------------|----------------|----------------|---|---|
| Soldering Dip  | Pre-heat       | Max. 100°C     | 60sec Max.                                | -   |
|                | Soldering Bath | Max. 265°C     | 5sec Max.                                 | In case of double peak flow soldering, the operation time is counted from the beginning of 1 <sup>st</sup> peak to the end of 2 <sup>nd</sup> peak. |
| Soldering Iron | Max. 400°C     | 3sec Max.      | The iron should not touch the LED's body. |   |

5. CLEANING

In case of cleaning, some solvents may cause damage of resin or cause non-lighting failure, so please check the solvent before actual use.

The recommendable cleaning solvent is alcoholic one such as isopropyl alcohol.

<RECOMMENDABLE CLEANING CONDITIONS>

| METHOD              | CONDITIONS                         |
|---------------------|------------------------------------|
| Cleaning by solvent | Temperature of solvent : Max. 45°C |
|                     | Immersion time : Max. 3min         |
| Cleaning by solvent | Ultrasonic out : Max. 15W/Liter    |
|                     | Cleaning time : Max. 3min          |

6. RECOMMENDABLE ROUND PATTERN

Round pattern depends on the material PCB, density and circuit arrangement.

Our recommendation is as follow :

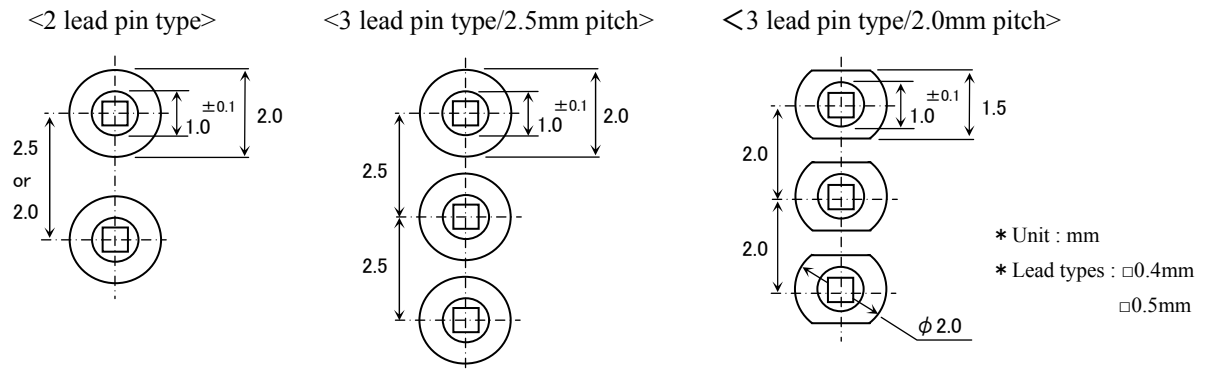

■ ATTENTION ON STORAGING

Storage in dry box is most desirable, but if it is not possible, we recommend following conditions.

<RECOMMENDABLE STORAGE CONDITIONS>

| ARTICLE    | Temperature | Humidity  | Expiration Date |
|------------|-------------|-----------|-----------------|
| CONDITIONS | 5~30°C      | Max.60%RH | Within 1 year   |

Poor storage conditions may cause some failure as bellow.

- (1) Lead pins may corrode if it is stored in the environment of high temperature and humidity and lead to defective soldering.
- (2) In case of soldering after LED's body absorb moisture highly, destruction or inferiority of luminous intensity may occur.

**■ APPLICATION METHOD**

## 1. Precaution for Drive System and Off Mode

- Design the circuit without the electric load exceeding the ABSOLUTE MAXIMUM RATING that applies on the products.
- If drive by constant voltage, it may cause current deviation of the LED and result in deviation of luminous intensity, so we recommend to drive by constant current. (Deviation of VF Value will cause deviation of current in LED.)
- Furthermore, for off mode, please do not apply voltage neither forward nor reverse. Especially, for the products with the Ag-paste used in the die bonding, there's high possibility to cause electro migration and result in function failure.

## 2. Operation Life Span

There's possibility for intensity of light drop according to working conditions and environments (applied current, surrounding temperature and humidity, corrosive gases ), please call our Sales staffs for inquiries about the concerned application below.

- (1) Longtime intensity of light life
- (2) On mode all the time

## 3. Usage

The Product is LED. We are not responsible for the usage as the diode such as Protection Chip, Rectifier, Switching and so on.

**■ OTHERS**

## 1. Surrounding Gas

Notice that if it is stored under the condition of acid gas (chlorine gas, sulfured gas) or alkali gas (ammonia), it may result in low soldering ability (caused by the change in quality of the plating surface ) or optical characteristics changes (light intensity, chrominance) and change in quality of die bonding (Ag-paste) materials. All of the above will cause function failure of the products.

Therefore, please pay attention to the storage environment for mounted product (concern the generated gas of the surrounding parts of the products and the atmospheric environment).

## 2. Electrostatic Damage

The product is part of semiconductor and electrostatic sensitive, there's high possibility to be damaged by the electrostatic discharge.



Please take appropriate measures to avoid the static electricity from human body and earthing setting of production equipment. The resistance values of electrostatic discharge (actual values) are different varies with products, therefore, please call our Sales staffs for inquiries.

## 3. Electromagnetic Wave

Please concern the influence on LED in case of application with strong electromagnetic wave such as IH (Induction heating).

## Looking for pricing, stock, or lifecycle information?

Click below to explore more details on WIN SOURCE:

-  [View SLR-332DCT32 on WIN SOURCE](#)
-  [Rohm Semiconductor](#) Information

## Optimize Your Supply Chain with WIN SOURCE Solutions

-  Global Sourcing Solution
-  Obsolete Management
-  Cost Control Management
-  Shortage Management
-  Alternative Solution
-  Excess Inventory Management