



# THE DATASHEET OF SP332CT-L



**Description**

The **SP332** is a monolithic device that contains both RS-232 and RS-485 line drivers and receivers. The configuration of the SP332 can be changed at any time by changing the logic state of two control pins. The device also includes a loop back function which internally connects driver outputs to receiver inputs for a chip self test. An MaxLinear-patented charge pump allows 5V-only operation.

**FEATURES**

- 5V only single supply operation
- Software programmable RS-232 or RS-485 selection
- 4 drivers, 4 receivers RS-232
- 2 drivers, 2 receivers RS-485
- Loop back function for self test
- 28-pin WSOIC package

Ordering Information - [Back Page](#)

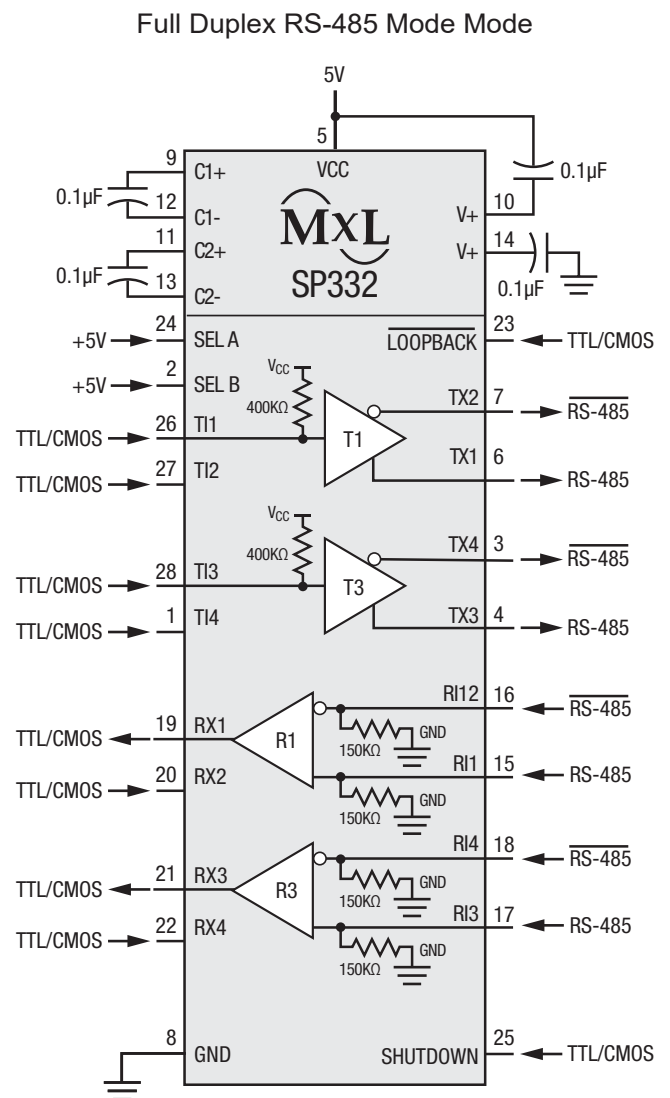
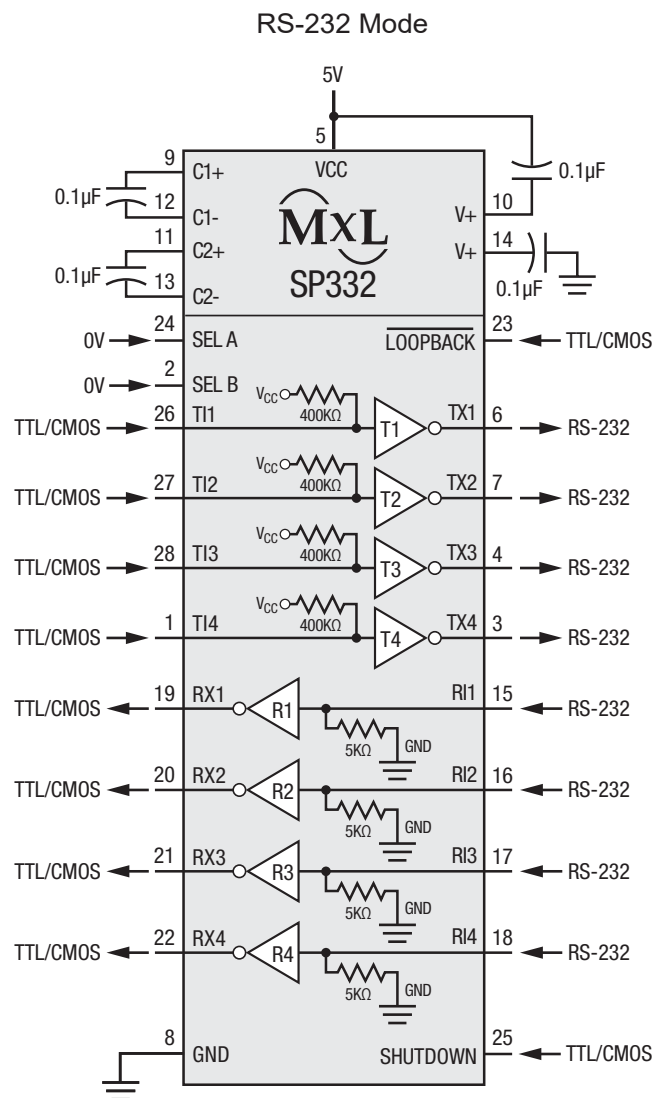
**Typical Applications Circuit**

## Absolute Maximum Ratings

These are stress ratings only and functional operation of the device at these ratings or any other above those indicated in the operation sections to the specifications below is not implied. Exposure to absolute maximum rating conditions for extended periods of time may affect reliability.

$V_{CC}$ .....	7V	Storage Temperature .....	-65°C to 150°C
Input Voltages		Power Dissipation	
Logic .....	-0.5V to ( $V_{CC} + 0.5V$ )	28-pin WSOIC .....	1000mW
Drivers .....	-0.5V to ( $V_{CC} + 0.5V$ )	Power Derating, $\theta_{JA}$	
Receivers.....	$\pm 30V @ \leq 100mA$	28-pin WSOIC .....	40°C/W
Driver Outputs .....	$\pm 15V$		
Maximum Data Rate.....	8Mbps <sup>(1)</sup>		

## Electrical Characteristics

Limits are specified at  $T_A = 25^\circ C$  and  $V_{CC} = 5.0V$  unless otherwise noted.

Parameters	Min.	Typ.	Max.	Units	Conditions
<b>RS-485 Driver DC Characteristics</b>					
Differential output voltage			$V_{CC}$	Volts	Unloaded; $R = \infty\Omega$ ; See Figure 1
Differential output voltage	2.0		5.0	Volts	With load; $R = 50\Omega$ (RS-422); See Figure 1
Differential output voltage	1.5		5.0	Volts	With load; $R = 27\Omega$ (RS-485); See Figure 1
Change in magnitude of driver differential output voltage for complementary states			0.2	Volts	$R = 27\Omega$ or $R = 50\Omega$ ; See Figure 1
Driver common-mode output voltage			3	Volts	$R = 27\Omega$ or $R = 50\Omega$ ; See Figure 1
Input high voltage	2.0			Volts	Applies to transmitter inputs, SEL A, SEL B, SD and $\overline{LB}$
Input low voltage			0.8	Volts	Applies to transmitter inputs, SEL A, SEL B, SD and $\overline{LB}$
Input current			$\pm 10$	$\mu A$	Applies to transmitter inputs, SEL A, SEL B, SD and $\overline{LB}$
Pull-up current		1.5		$\mu A$	
Pull-down current		3.0		$\mu A$	
Driver short circuit current $V_{OUT} = HIGH$	35		250	mA	$-7V \leq V_O \leq 10V$
Driver short circuit current $V_{OUT} = LOW$	35		250	mA	$-7V \leq V_O \leq 10V$
<b>RS-485 Driver AC Characteristics</b>					
Driver data rate	10			Mbps	
Driver data rate			8	Mbps	$T_A = 85^\circ C^{(1)}$
Driver input to output $t_{PLH}$		70	180	ns	$R_{DIFF} = 54\Omega$ , $C_{L1} = C_{L2} = 100pF$ ; see Figures 3 and 5
Driver input to output $t_{PHL}$		70	180	ns	$R_{DIFF} = 54\Omega$ , $C_{L1} = C_{L2} = 100pF$ ; see Figures 3 and 5
Driver skew		5	10	ns	From output to output; see Figures 3 and 5
Driver rise or fall time	3	15	40	ns	From 10% to 90%; $R_{DIFF} = 54\Omega$ , $C_{L1} = C_{L2} = 100pF$ ; see Figures 3 and 5

## Electrical Characteristics (Continued)

Limits are specified at  $T_A = 25^\circ\text{C}$  and  $V_{CC} = 5.0\text{V}$  unless otherwise noted.

Parameters	Min.	Typ.	Max.	Units	Conditions
<b>RS-485 Receiver DC Characteristics</b>					
Differential input threshold	-0.2		0.2	Volts	$-7\text{V} \leq V_{CM} \leq 12\text{V}$
Input hysteresis		70		mV	$V_{CM} = 0\text{V}$
Output voltage HIGH	3.5			Volts	$I_O = -4\text{mA}$ , $V_{ID} = 200\text{mV}$
Output voltage LOW			0.4	Volts	$I_O = 4\text{mA}$ , $V_{ID} = -200\text{mV}$
Input resistance	12	15		k $\Omega$	$-7\text{V} \leq V_{CM} \leq 12\text{V}$
Input current (A, B); $V_{IN} = 12\text{V}$			1.5	mA	$V_{IN} = 12\text{V}$ , A is the non-inverting receiver input. B is the inverting receiver input
Input current (A, B); $V_{IN} = -7\text{V}$			-0.8	mA	$V_{IN} = -7\text{V}$
Short circuit current			85	mA	$0\text{V} \leq V_{CM} \leq V_{CC}$
<b>RS-485 Receiver AC Characteristics</b>					
Receiver data rate	10			Mbps	
Receiver data rate			8	Mbps	$T_A = 85^\circ\text{C}^{(1)}$
Receiver input to output $t_{PLH}$		130	250	ns	$R_{DIFF} = 54\Omega$ , $C_{L1} = C_{L2} = 100\text{pF}$ ; Figures 3 and 6
Receiver input to output $t_{PHL}$		130	250	ns	$R_{DIFF} = 54\Omega$ , $C_{L1} = C_{L2} = 100\text{pF}$ ; Figures 3 and 6
Differential receiver skew $ t_{PHL} - t_{PLH} $		13		ns	$R_{DIFF} = 54\Omega$ , $C_{L1} = C_{L2} = 100\text{pF}$ ; Figures 3 and 6
<b>RS-232 Driver DC Characteristics</b>					
TTL input level $V_{IL}$			0.8	Volts	Applies to transmitter inputs, SEL A, SEL B, SD and $\overline{\text{LB}}$
TTL input level $V_{IH}$	2.0			Volts	Applies to transmitter inputs, SEL A, SEL B, SD and $\overline{\text{LB}}$
High level voltage output	5.0		15.0	Volts	$R_L = 3\text{k}\Omega$ to GND
Low level voltage output	-15.0		-5.0	Volts	$R_L = 3\text{k}\Omega$ to GND
Open circuit output			$\pm 15$	Volts	$R_L = \infty$
Short circuit current			$\pm 100$	mA	$V_{OUT} = 0\text{V}$
Power off impedance	300			$\Omega$	$V_{CC} = 0\text{V}$ ; $V_{OUT} = \pm 2\text{V}$
<b>RS-232 Driver AC Characteristics</b>					
Transmission rate	120			kbps	
Transition time			1.56	$\mu\text{s}$	Rise/fall time, 3V to -3V; -3V to 3V, $R_L = 3\text{k}\Omega$ , $C_L = 2500\text{pF}$
Propagation delay; $t_{PHL}$		2	4	$\mu\text{s}$	$R_L = 3\text{k}\Omega$ , $C_L = 2500\text{pF}$ , from 1.5V of $T_{IN}$ to 50% of $V_{OUT}$
Propagation delay; $t_{PLH}$		2	4	$\mu\text{s}$	$R_L = 3\text{k}\Omega$ , $C_L = 2500\text{pF}$ , from 1.5V of $T_{IN}$ to 50% of $V_{OUT}$
Slew rate		10	30	V/ $\mu\text{s}$	$R_L = 3\text{k}\Omega$ , $C_L = 50\text{pF}$ ; From 3V to -3V or -3V to 3V

## Electrical Characteristics (Continued)

Limits are specified at  $T_A = 25^\circ\text{C}$  and  $V_{CC} = 5.0\text{V}$  unless otherwise noted.

Parameters	Min.	Typ.	Max.	Units	Conditions
<b>RS-232 Receiver DC Characteristics</b>					
TTL output level; $V_{OL}$			0.4	Volts	$I_{SINK} = 4\text{mA}$
TTL output level; $V_{OH}$	3.5			Volts	$I_{SOURCE} = -4\text{mA}$
Input high threshold		2.1	3.0	Volts	
Input low threshold	0.8	1.6		Volts	
Input voltage range	-15		15	Volts	
Input impedance	3	5	7	$k\Omega$	$V_{IN} = \pm 15\text{V}$
Hysteresis	0.2	0.5	1.0	Volts	$V_{CC} = 5\text{V}$
<b>RS-232 Receiver AC Characteristics</b>					
Transmission rate	120			kbps	
Transition time		50		ns	Rise/fall time, 10% to 90%
Propagation delay $t_{PHL}$		100	300	ns	From 50% of $V_{IN}$ to 1.5V of $R_{OUT}$
Propagation delay $t_{PLH}$		100	200	ns	
<b>Power Requirements</b>					
No load supply current		19	25	mA	No load; $V_{CC} = 5.0\text{V}$ ; $T_A = 25^\circ\text{C}$
Full load supply current		90	120	mA	RS-232 drivers $R_L = 3k\Omega$ to GND, DC input RS-485 drivers $R_L = 54\Omega$ from A to B; DC input
Shutdown supply current		5	50	$\mu\text{A}$	$T_A = 25^\circ\text{C}$ , $V_{CC} = 5.0\text{V}$

### NOTE

- Exceeding the maximum data rate may damage the device.

Test Circuits

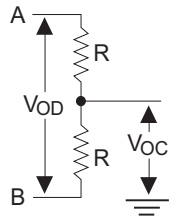

Figure 1: RS-485 Driver DC Test Load Circuit

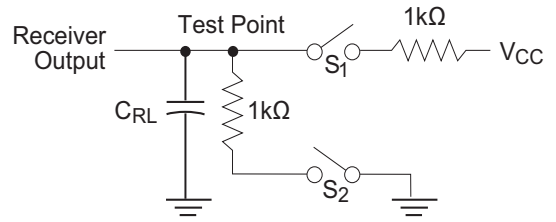

Figure 2: Receiver Timing Test Load Circuit

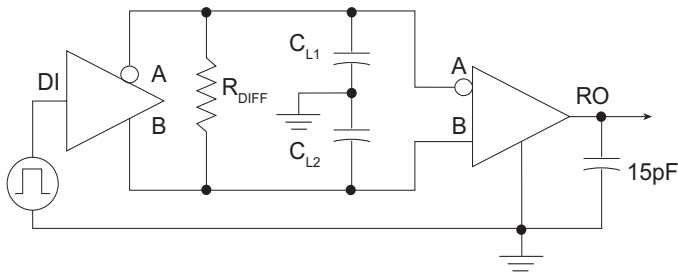

Figure 3: RS-485 Driver/Receiver Timing Test Circuit

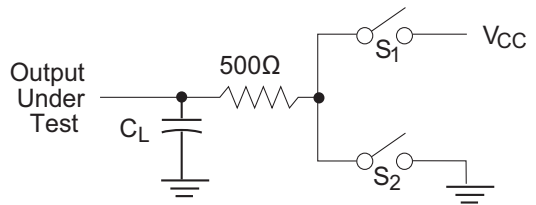

Figure 4: RS-485 Driver Timing Test Load #2 Circuit

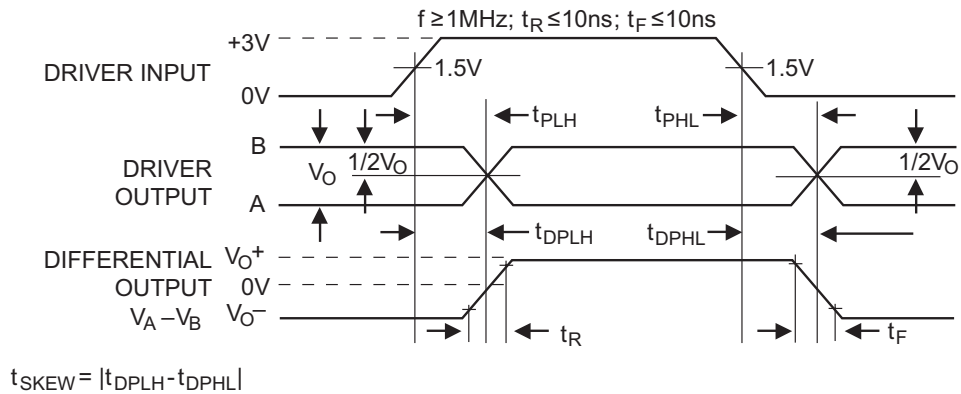

Figure 5: RS-485 Driver Propagation Delays

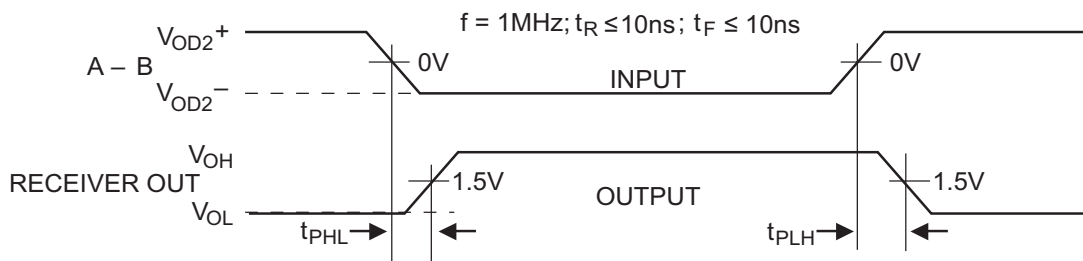
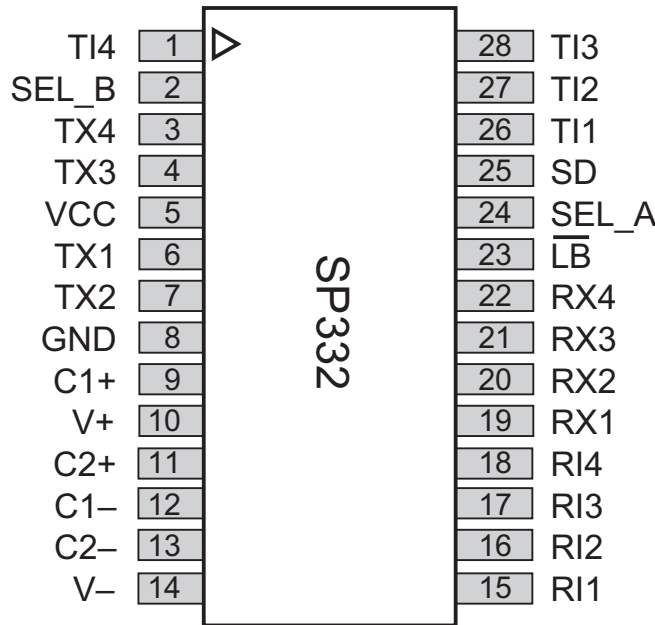

Figure 6: RS-485 Receiver Propagation Delays

Pin Configuration



Typical Applications Circuits

RS-232 Mode

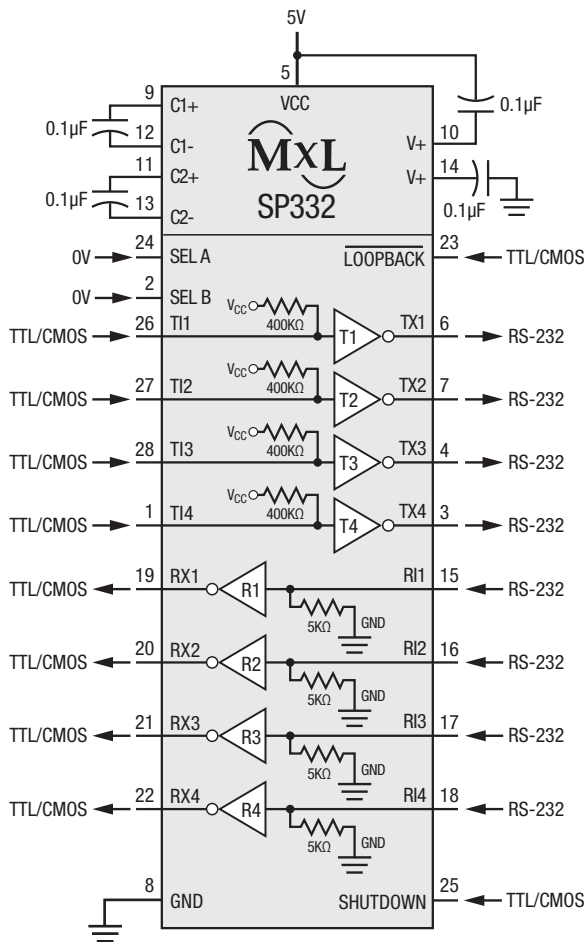

Full Duplex RS-485 Mode Mode

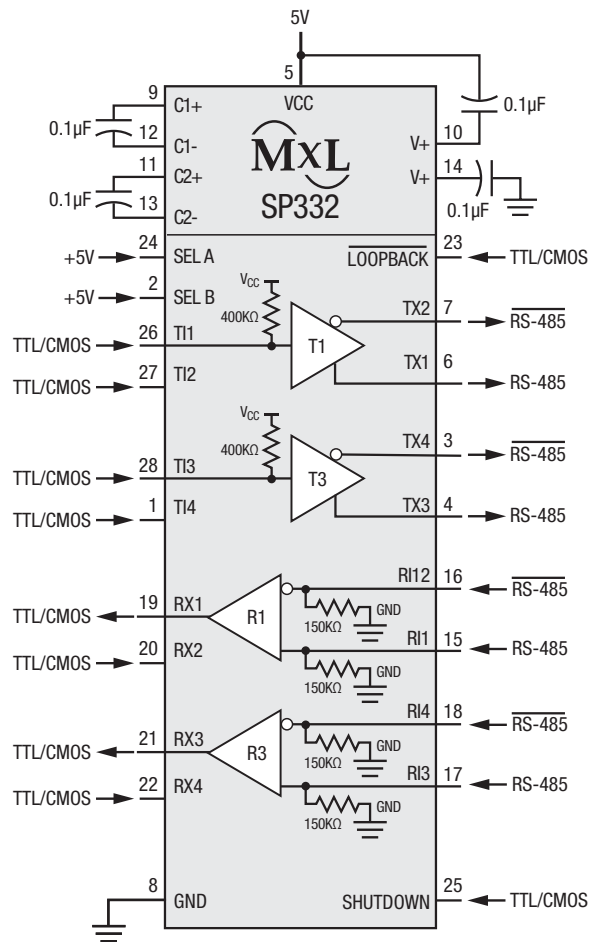

SP332 Control Logic Configuration

SEL A	0	0	1	1
SEL B	0	1	0	1
$\overline{\text{LB}}$	1	1	1	1
SD	0	0	0	0
SEL A	0	0	1	1
SEL B	0	1	0	1
$\overline{\text{LB}}$	0	0	0	0
SD	0	0	0	0

Receiver Inputs are inactive in Loopback Mode ( $\overline{\text{LOOPBACK}} = 0$ )  
 Driver Outputs are Tri-stated in Loopback Mode ( $\overline{\text{LOOPBACK}} = 0$ )  
 Unused Outputs are Tri-stated

## Functional Description

The SP332 is single chip device that can be configured via software for either RS-232, RS-485 or both interface modes at any time. The SP332 is made up of three basic circuit elements, single-ended drivers and receivers, differential drivers and receivers and charge pump.

### Differential Driver/Receiver

#### RS-485, RS-422 Drivers

The differential drivers and receivers comply with the RS-485 and RS-422 standards. The driver circuits are able to drive a minimum of 1.5V when terminated with a 54 $\Omega$  resistor across the two outputs. The typical propagation delay from driver input to output is 60ns. The driver outputs are current limited to less than 250mA, and can tolerate shorts to ground, or to any voltage within a 10V to -7V range with no damage.

#### RS-485, RS-422 Receivers

The differential receivers of the SP332 comply with the RS-485 and RS-422 standards. The input to the receiver is equipped with a common mode range of 12V to -7V. The input threshold over this range is a minimum of  $\pm 200$ mV. The differential receivers can receive data up to 10Mbps. The typical propagation delay from the receiver input to output is 90ns.

### Single Ended Driver / Receiver

#### RS-232 (V.28) Drivers

The single-ended drivers and receivers comply with the RS-232 and V.28 standards. The drivers are inverting transmitters which accept either TTL or CMOS inputs and output the RS-232 signals with an inverted sense relative to the input logic levels. Typically, the RS-232 driver output voltage swing is  $\pm 9$ V with no load and is guaranteed to be greater than  $\pm 5$ V under full load. The drivers rely on the V+ and V- voltages generated by the on-chip charge pump to maintain proper RS-232 output levels. With worst case load conditions of 3k $\Omega$  and 2500pF, the four RS-232 drivers can still maintain  $\pm 5$ V output levels. The drivers can operate up to 120kbps; the propagation delay from input to output is typically 2 $\mu$ s.

#### RS-232 (V.28) Receivers

The RS-232 receivers convert RS-232 input signals to inverted TTL signals. Each of the four receivers features 500mV of hysteresis margin to minimize the affects of noisy transmission lines. The inputs also have a 5k $\Omega$  resistor to ground, in an open circuit situation the input of the receiver will be forced low, committing the output to a logic high state. The input resistance will maintain 3k $\Omega$  to

7k $\Omega$  over a  $\pm 15$ V range. The maximum operating voltage range for the receiver is  $\pm 30$ V, under these conditions the input current to the receiver must be limited to less than 100mA. Due to the on-chip ESD protection circuitry, the receiver inputs will be clamped to  $\pm 15$ V levels. The RS-232 receivers can operate up to 120kbps.

### Charge-Pump

The charge pump is a MaxLinear-patented design (U.S. 5,306,954) and uses a unique approach compared to older less efficient designs. The charge pump still requires four external capacitors, but uses a four-phase voltage shifting technique to attain symmetrical 10V power supplies. Figure 7(a) shows the waveform found on the positive side of capacitor C<sub>2</sub>, and Figure 7(b) shows the negative side of capacitor C<sub>2</sub>. There is a free-running oscillator that controls the four phases of the voltage shifting. A description of each phase follows.

#### Phase 1 — V<sub>SS</sub> charge storage

During this phase of the clock cycle, the positive side of capacitors C<sub>1</sub> and C<sub>2</sub> are initially charged to 5V. C<sub>1</sub><sup>+</sup> is then switched to ground and charge on C<sub>1</sub><sup>-</sup> is transferred to C<sub>2</sub><sup>-</sup>. Since C<sub>2</sub><sup>+</sup> is connected to 5V, the voltage potential across capacitor C<sub>2</sub> is now 10V.

#### Phase 2 — V<sub>SS</sub> transfer

Phase two of the clock connects the negative terminal of C<sub>2</sub> to the V<sub>SS</sub> storage capacitor and the positive terminal of C<sub>2</sub> to ground, and transfers the generated -10V to C<sub>3</sub>. Simultaneously, the positive side of capacitor C<sub>1</sub> is switched to 5V and the negative side is connected to ground.

#### Phase 3 — V<sub>DD</sub> charge storage

The third phase of the clock is identical to the first phase — the charge transferred in C<sub>1</sub> produces -5V in the negative terminal of C<sub>1</sub>, which is applied to the negative side of capacitor C<sub>2</sub>. Since C<sub>2</sub><sup>+</sup> is at +5V, the voltage potential across C<sub>2</sub> is 10V.

#### Phase 4 — V<sub>DD</sub> transfer

The fourth phase of the clock connects the negative terminal of C<sub>2</sub> to ground and transfers the generated 10V across C<sub>2</sub> to C<sub>4</sub>, the V<sub>DD</sub> storage capacitor. Again, simultaneously with this, the positive side of capacitor C<sub>1</sub> is switched to 5V and the negative

side is connected to ground, and the cycle begins again.

Since both  $V^+$  and  $V^-$  are separately generated from  $V_{CC}$  in a no-load condition,  $V^+$  and  $V^-$  will be symmetrical. Older charge pump approaches that generate  $V^-$  from  $V^+$  will show a decrease in the

magnitude of  $V^-$  compared to  $V^+$  due to the inherent inefficiencies in the design.

The clock rate for the charge pump typically operates at 15kHz. The external capacitors must be 0.1 $\mu$ F with a 16V breakdown rating.

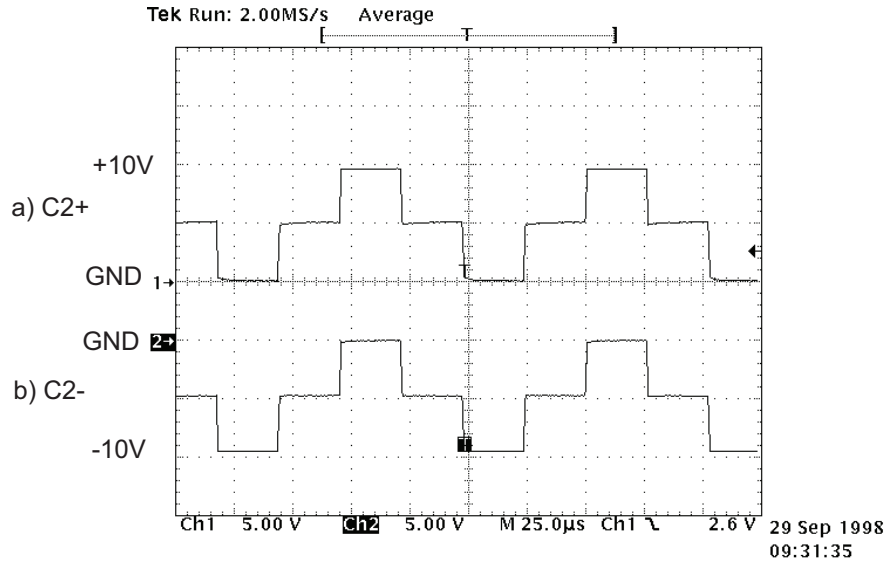

Figure 7: Charge Pump Waveforms

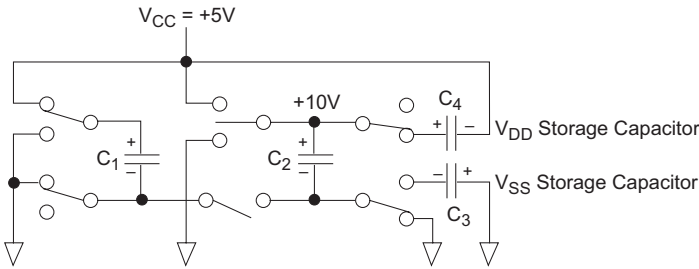

Figure 8: Charge Pump Phase 1

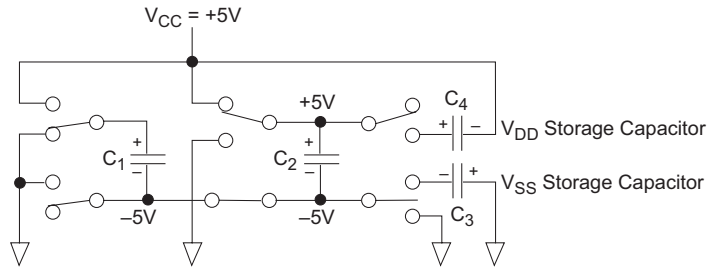

Figure 9: Charge Pump Phase 3

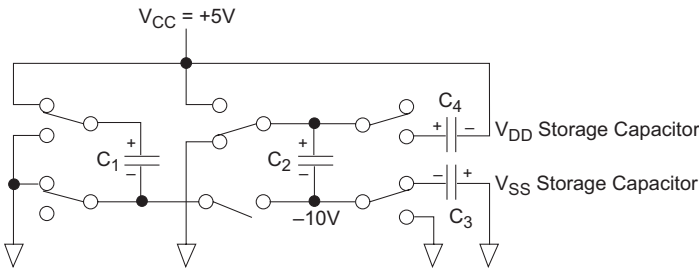

Figure 10: Charge Pump Phase 2

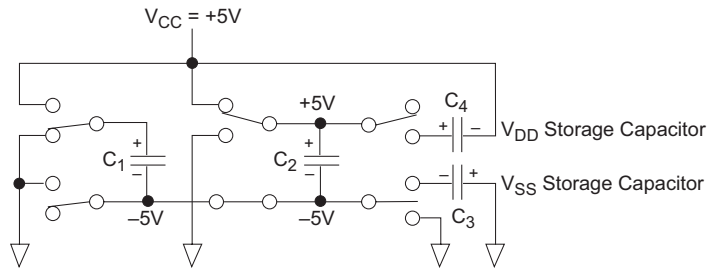
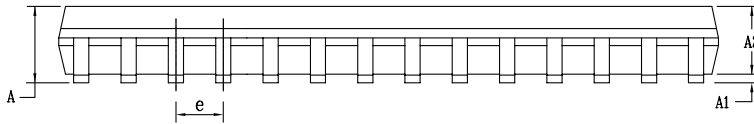
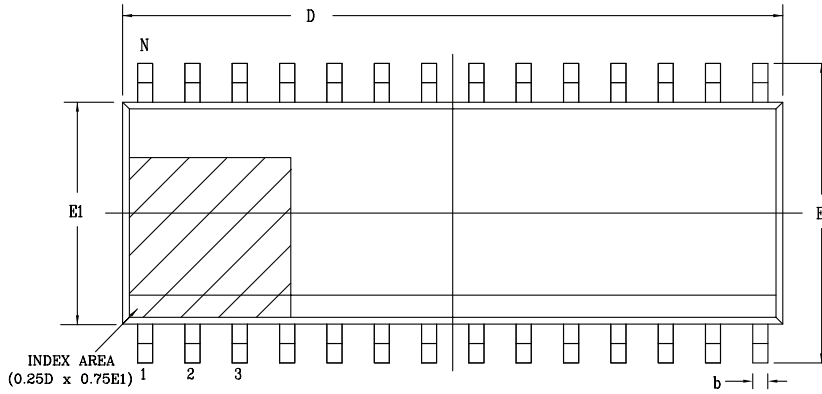

Figure 11: Charge Pump Phase 4

Package Description

WSOIC28

Top View



Side View

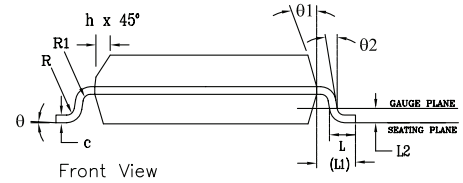

Front View

PACKAGE OUTLINE SOIC .300" BODY JEDEC MS-013 VARIATION AE						
SYMBOLS	COMMON DIMENSIONS IN MM (Control Unit)			COMMON DIMENSIONS IN MM (Reference Unit)		
	MIN	NOM	MAX	MIN	NOM	MAX
A	2.35	—	2.65	0.093	—	0.104
A1	0.10	—	0.30	0.004	—	0.012
A2	2.05	—	2.55	0.081	—	0.100
b	0.31	—	0.51	0.012	—	0.020
c	0.20	—	0.33	0.008	—	0.013
E	10.30 BSC			0.406 BSC		
E1	7.50 BSC			0.295 BSC		
e	1.27 BSC			0.050 BSC		
h	0.25	—	0.75	0.010	—	0.030
L	0.40	—	1.27	0.016	—	0.050
L1	1.40 REF			0.055 REF		
L2	0.25 BSC			0.010 BSC		
R	0.07	—	—	0.003	—	—
R1	0.07	—	—	0.003	—	—
$\theta$	0°	—	8°	0°	—	8°
$\theta1$	5°	—	15°	5°	—	15°
$\theta2$	0°	—	—	0°	—	—
D	17.90 BSC			0.705 BSC		
N	28					

Drawing No: POD-00000106

Revision: A

Ordering Information<sup>(1)</sup>

Part Number	Operating Temperature Range	Lead-Free	Package	Packaging Method
SP332CT-L	0°C to 70°C	Yes <sup>(2)</sup>	28-pin WSOIC	Tube
SP332CT-L/TR <sup>(3)</sup>				Reel
SP332ET-L	-40°C to 85°C			Tube
SP332ET-L/TR				Reel

**NOTE:**

1. Refer to [www.exar.com/SP332](http://www.exar.com/SP332) for most up-to-date Ordering Information.
2. Visit [www.exar.com](http://www.exar.com) for additional information on Environmental Rating.
3. NRND - Not recommended for new designs.

## Revision History

Revision	Date	Description
9617RO	-	Legacy Sipex Datasheet
01/26/10	1.0.0	Convert to Exar Format. Add Revision History table. Change revision to 1.0.0. Add Note 1 and change maximum RS-485 data rate at +85C. Update ABS Max Rating table.
10/16/17	1.0.1	Remove GND from Differential Output Voltage min (page 2). Update to MaxLinear logo. Update format and ordering information table. Theory of Operation section moved to after SP332 Control Logic Configuration section, and renamed Functional Description.

**Corporate Headquarters:**

5966 La Place Court  
Suite 100  
Carlsbad, CA 92008  
Tel.: +1 (760) 692-0711  
Fax: +1 (760) 444-8598  
[www.maxlinear.com](http://www.maxlinear.com)

**High Performance Analog:**

1060 Rincon Circle  
San Jose, CA 95131  
Tel.: +1 (669) 265-6100  
Fax: +1 (669) 265-6101  
Email: [serial\\_techsupport@exar.com](mailto:serial_techsupport@exar.com)  
[www.exar.com](http://www.exar.com)

The content of this document is furnished for informational use only, is subject to change without notice, and should not be construed as a commitment by MaxLinear, Inc.. MaxLinear, Inc. assumes no responsibility or liability for any errors or inaccuracies that may appear in the informational content contained in this guide. Complying with all applicable copyright laws is the responsibility of the user. Without limiting the rights under copyright, no part of this document may be reproduced into, stored in, or introduced into a retrieval system, or transmitted in any form or by any means (electronic, mechanical, photocopying, recording, or otherwise), or for any purpose, without the express written permission of MaxLinear, Inc.

MaxLinear, Inc. does not recommend the use of any of its products in life support applications where the failure or malfunction of the product can reasonably be expected to cause failure of the life support system or to significantly affect its safety or effectiveness. Products are not authorized for use in such applications unless MaxLinear, Inc. receives, in writing, assurances to its satisfaction that: (a) the risk of injury or damage has been minimized; (b) the user assumes all such risks; (c) potential liability of MaxLinear, Inc. is adequately protected under the circumstances.

MaxLinear, Inc. may have patents, patent applications, trademarks, copyrights, or other intellectual property rights covering subject matter in this document. Except as expressly provided in any written license agreement from MaxLinear, Inc., the furnishing of this document does not give you any license to these patents, trademarks, copyrights, or other intellectual property.

Company and product names may be registered trademarks or trademarks of the respective owners with which they are associated.

© 2010-2017 MaxLinear, Inc. All rights reserved

## Looking for pricing, stock, or lifecycle information?

Click below to explore more details on WIN SOURCE:

 [View SP332CT-L on WIN SOURCE](#)

 [MaxLinear Inc Information](#)

## Optimize Your Supply Chain with WIN SOURCE Solutions

-  Global Sourcing Solution
-  Obsolete Management
-  Cost Control Management
-  Shortage Management
-  Alternative Solution
-  Excess Inventory Management