



**THE DATASHEET OF  
AS3643-ZWLT-500**





**austriamicrosystems AG**

**is now**

**ams AG**

The technical content of this austriamicrosystems datasheet is still valid.

**Contact information:**

**Headquarters:**

ams AG

Tobelbaderstrasse 30

8141 Unterpremstaetten, Austria

Tel: +43 (0) 3136 500 0

e-Mail: [ams\\_sales@ams.com](mailto:ams_sales@ams.com)

Please visit our website at [www.ams.com](http://www.ams.com)

# AS3643

## 1300mA High Current LED Flash Driver



### 1 General Description

The AS3643 is an inductive high efficient DCDC step up converter with two current sinks. The DCDC step up converter operates at a fixed frequency of 4MHz and includes soft startup to allow easy integration into noise sensitive RF systems. The two current sinks can operate in flash / torch / assist (=video) light modes.

The AS3643 includes flash timeout, overvoltage, over-temperature, undervoltage and LED short circuit protection functions. A TXMASK/TORCH function reduces the flash current in case of parallel operation to the RF power amplifier and avoids a system shutdown. Alternatively this pin can be used to directly operate the torch light directly.

The AS3643 is controlled by an I<sup>2</sup>C interface and has a hardware automatic shutdown if SCL=0 for 100ms. Therefore no additional enable input is required for shutting down of the device once the system shuts down.

The AS3643 is available in a space-saving WL-CSP package measuring only 2.25x1.5x0.6mm and operates over the -30°C to +85°C temperature range.

Figure 1. Typical Operating Circuit

### 2 Key Features

- High efficiency 4MHz fixed frequency DCDC Boost converter with soft start allows small coils
  - Stable even in coil current limit
- LED current adjustable up to 1300mA
- Automatic current adjustment for low battery voltage
- PWM operation for lower output current for reliable light output of the LED; running at 31.25kHz to avoid audible noise
- Protection functions:
  - Automatic Flash Timeout timer to protect the LED(s)
  - Overvoltage and undervoltage Protection
  - Overtemperature Protection
  - LED short/open circuit protection
- I<sup>2</sup>C Interface with automatic shutdown
- 5V constant voltage mode operation
- Available in tiny WL-CSP Package, 13 balls 0.5mm pitch 2.25x1.5x0.6mm, package size

### 3 Applications

Flash/torch/videolight for smartphones, feature-phones, tablets, DSCs, DVCs

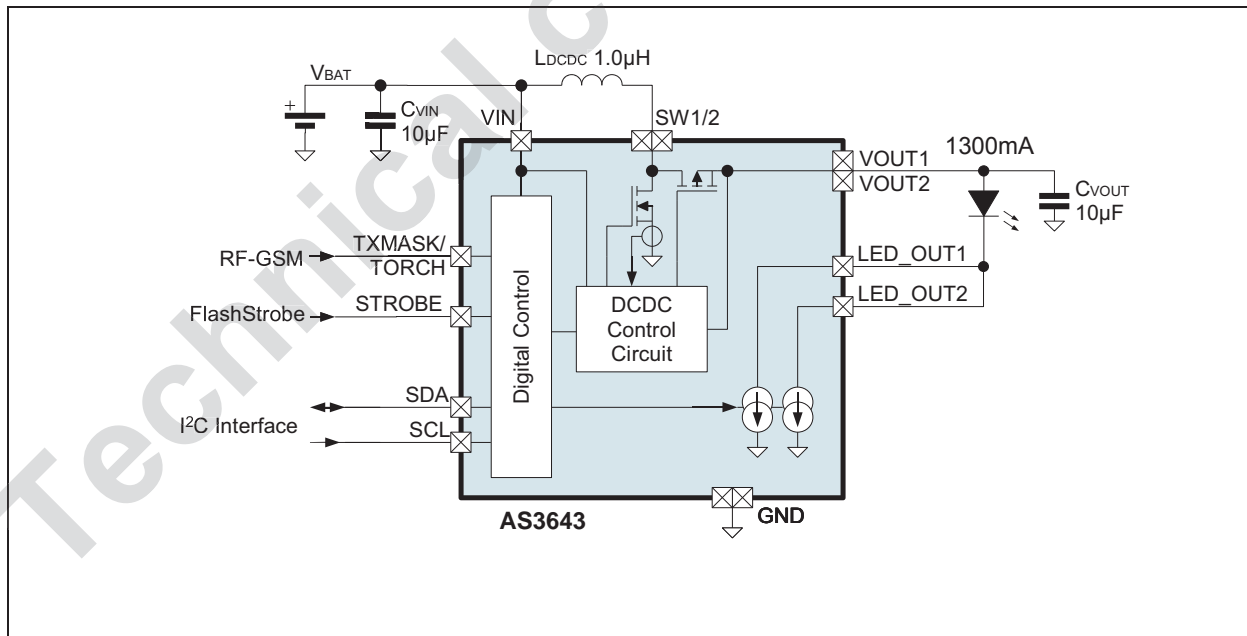

## 4 Pinout

### Pin Assignment

Figure 2. Pin Assignments (Top View)

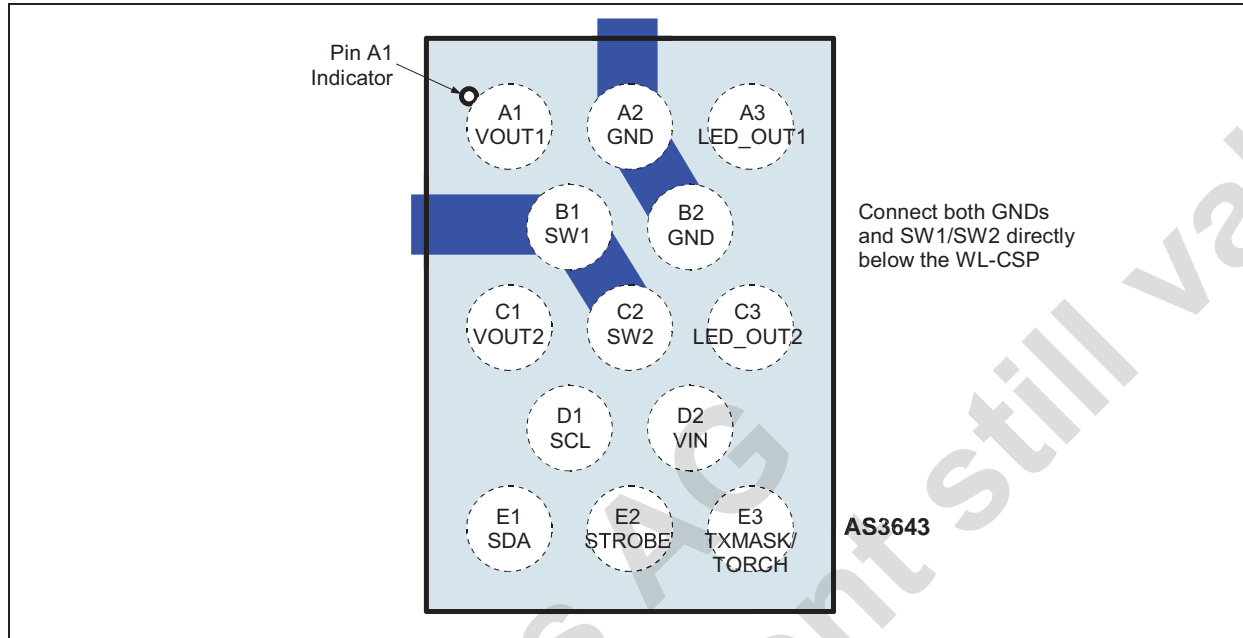

### Pin Description

Table 1. Pin Description for AS3643

Pin Number	Pin Name	Description
A1	VOUT1	DCDC converter output capacitor - make a short connection to C <sub>VOUT</sub> / VOUT2
A2	GND	Power and analog ground; make a short connection between both balls
A3	LED_OUT1	Flash LED current sink
B1	SW1	DCDC converter switching node - make a short connection to SW2 / coil L <sub>DCDC</sub>
B2	GND	Power and analog ground; make a short connection between both balls
C1	VOUT2	DCDC converter output capacitor - make a short connection to C <sub>VOUT</sub> / VOUT1
C2	SW2	DCDC converter switching node - make a short connection to SW1 /coil L <sub>DCDC</sub>
C3	LED_OUT2	Flash LED current sink
D1	SCL	serial clock input for I <sup>2</sup> C interface
D2	VIN	Positive supply voltage input - connect to supply and make a short connection to input capacitor C <sub>VIN</sub> and to coil L <sub>DCDC</sub>
E1	SDA	serial data input/output for I <sup>2</sup> C interface (needs external pullup resistor)
E2	STROBE	Digital input with pulldown to control strobe time for flash function
E3	TXMASK/ TORCH	Function 1: Connect to RF power amplifier enable signal - reduces currents during flash to avoid a system shutdown due to parallel operation of the RF PA and the flash driver Function 2: Operate torch current level without using the I <sup>2</sup> C interface to operate the torch without need to start a camera processor (if the I <sup>2</sup> C is connected to the camera processor)

## 5 Absolute Maximum Ratings

Stresses beyond those listed in Table 3 may cause permanent damage to the device. These are stress ratings only, and functional operation of the device at these or any other conditions beyond those indicated in Table 4, "Electrical Characteristics," on page 4 is not implied. Exposure to absolute maximum rating conditions for extended periods may affect device reliability.

Table 3. Absolute Maximum Ratings

Parameter	Min	Max	Units	Comments
VIN to GND	-0.3	+7.0	V	
STROBE, TXMASK/TORCH, SCL, SDA to GND	-0.3	VIN + 0.3	V	max. +7V
SW1/2, VOUT1/2, LED_OUT1/2 to GND	-0.3	+7.0	V	
VOUT1/2 to SW1/2	-0.3		V	<b>Note:</b> Diode between VOUT1/2 and SW1/2
voltage between GND pins	0.0	0.0	V	short connection recommended
Input Pin Current without causing latchup	-100	+100 +IIN	mA	Norm: EIA/JESD78
<b>Continuous Power Dissipation (TA = +70°C)</b>				
Continuous power dissipation		1230	mW	PT at 70°C <sup>1</sup>
Continuous power dissipation derating factor		16.7	mW/°C	PDERATE <sup>2</sup>
<b>Electrostatic Discharge</b>				
ESD HBM pins LED_OUT1/2 <sup>3</sup>		±8000	V	Norm: JEDEC JESD22-A114F
ESD HBM		±2000	V	
ESD CDM		±500	V	Norm: JEDEC JESD 22-C101E
ESD MM		±100	V	Norm: JEDEC JESD 22-A115-B
<b>Temperature Ranges and Storage Conditions</b>				
Junction to ambient thermal resistance		60 <sup>4</sup>	°C/W	For more information about thermal metrics, see application note AN01 Thermal Characteristics
Junction Temperature		+150	°C	Internally limited (overtemperature protection), max. 20000s
Storage Temperature Range	-55	+125	°C	
Humidity	5	85	%	Non condensing
Body Temperature during Soldering		+260	°C	according to IPC/JEDEC J-STD-020
Moisture Sensitivity Level (MSL)		MSL 1		Represents a max. floor life time of unlimited

1. Depending on actual PCB layout and PCB used measured on demoboard; for peak power dissipation during flashing see document 'AS3643 Thermal Measurements'
2. PDERATE derating factor changes the total continuous power dissipation (PT) if the ambient temperature is not 70°C. Therefore for e.g. TAMB=85°C calculate PT at 85°C = PT - PDERATE \* (85°C - 70°C)
3. Pins LED\_OUT1 connected to LED\_OUT2 and capacitor CVOUT connected to VOUT1/2 and GND; both GND pins connected together
4. Measured on AS3643 Demoboard.

## 6 Electrical Characteristics

V<sub>VIN</sub> = +2.7V to +4.4V, T<sub>AMB</sub> = -30°C to +85°C, unless otherwise specified. Typical values are at V<sub>VIN</sub> = +3.7V, T<sub>AMB</sub> = +25°C, unless otherwise specified.

Table 4. Electrical Characteristics

Symbol	Parameter	Condition	Min	Typ	Max	Unit
<b>General Operating Conditions</b>						
V <sub>VIN</sub>	Supply Voltage	pin VIN	2.7	3.7	4.4	V
V <sub>VINREDUCE_D_FUNC</sub>	Supply Voltage	AS3643 functionally working, but not all parameters fulfilled	2.5 4.4		2.7 5.5	V
I <sub>SHUTDOWN</sub>	Shutdown Current	TXMASK/TORCH=L, SCL=SDA=0V, V <sub>VIN</sub> <3.7V		0.6	2.0	µA
I <sub>STANBY</sub>	Standby Current	interface active, TXMASK/TORCH=L, V <sub>VIN</sub> <3.7V <sup>1</sup>		1.0	10	µA
T <sub>AMB</sub>	Operating Temperature		-30	25	85	°C
Eta	Application Efficiency (DCDC and current sink)	L <sub>COIL</sub> =0.6µH@3A, L <sub>ESR</sub> =60mΩ, LED_OUT1,2=1300mA <sup>2</sup> , t <sub>FLASH</sub> <300ms		84		%
<b>DCDC Step Up Converter</b>						
V <sub>VOUT</sub>	DCDC Boost output Voltage (pin VOUT1/2)		2.8		5.5	V
V <sub>VOUT5V</sub>	DCDC Boost output Voltage (pin VOUT1/2)	constant voltage mode operation const_v_mode (see page 23)=1		5.0		V
R <sub>PMOS</sub>	On-resistance	DCDC internal PMOS switch		70		mΩ
R <sub>NMOS</sub>	On-resistance	DCDC internal NMOS switch		70		mΩ
f <sub>CLK</sub>	Operating Frequency	All internal timings are derived from this oscillator	-7.5%	4.0	+7.5%	MHz
<b>Current Sinks</b>						
V <sub>LED</sub>	LED forward voltage	single LED at 1300mA	2.8	3.4	4.2	V
I <sub>LED_OUT</sub>	LED_OUT1/2 current sinks output combined	single LED	0		1300	mA
I <sub>LED_OUTΔ</sub>	LED_OUT1/2 current sink accuracy	I <sub>LED_OUT</sub> >650mA or I <sub>LED_OUT</sub> <500mA 0°C < T <sub>J</sub> < 100°C	-7		+7	%
		500mA<I <sub>LED_OUT</sub> <650mA, 0°C < T <sub>J</sub> < 100°C	-5		+5	%
I <sub>LED_OUT RAMP</sub>	LED_OUT1/2 ramp time	Ramp-up During startup		250	1000	µs
		Ramp-down		500	1000	µs
I <sub>LED_OUT RIPPLE</sub>	LED_OUT current ripple	I <sub>LED_OUT</sub> = 1000mA, BW=20MHz		20		mAPP
V <sub>ILED_COMP</sub>	LED_OUT current sink voltage compliance	Minimum voltage between pin LED_OUT1/2 and GND for operation of the current sink		286		mV
V <sub>HIGH_VDS</sub>	Comparator High VDS	low vds and high vds comparator - see 4MHz/ 1MHz Operating Mode Switching on page 11		870		mV
V <sub>LOW_VDS</sub>	Comparator Low VDS			280		
I <sub>LEAK_LED_OUT</sub>	LED_OUT1/2 Leakage Current	Pins LED_OUT1 and LED_OUT2	-1.0	0.0	+1.0	µA
<b>Protection and Fault Detection Functions (see page 11)</b>						

Table 4. Electrical Characteristics (Continued)

Symbol	Parameter	Condition	Min	Typ	Max	Unit	
V <sub>VOUTMAX</sub>	V <sub>VOUT</sub> overvoltage protection	DCDC Converter Overvoltage Protection	5.0	5.3	5.6	V	
I <sub>LIMIT</sub>	Current Limit for coil LDCDC (Pin SW) measured at 40% <sup>3</sup> PWM duty cycle maximum 40000s lifetime operation in overcurrent limit	coil_peak=00b		1.0		A	
		coil_peak=01b		1.5			
		default value	coil_peak=10b	1.8	2.0		2.23
		coil_peak=11b		2.5			
V <sub>LLEDSHORT</sub>	Flash LED short circuit detection voltage	Voltage measured between pins V <sub>OUT1,2</sub> and LED_OUT1,2		1.0		V	
T <sub>OVTEMP</sub>	Overtemperature Protection	Junction temperature		144		°C	
T <sub>OVTEMPHYST</sub>	Overtemperature Hysteresis			5		°C	
t <sub>FLASHTIMEOUT</sub>	Flash Timeout Timer	Can be adjusted with register flash_timeout (page 24)	2		1280	ms	
		accuracy	-7.5		+7.5	%	
V <sub>VULO</sub>	Undervoltage Lockout	Falling V <sub>VIN</sub>	2.25	2.4	2.5	V	
		Rising V <sub>VIN</sub>	V <sub>VULO</sub> +0.05	V <sub>VULO</sub> +0.1	V <sub>VULO</sub> +0.15	V	
<b>Digital Interface</b>							
V <sub>IH</sub>	High Level Input Voltage	Pins SCL, SDA. Pin TXMASK/TORCH in external torch mode (ext_torch_on=10)	1.26		V <sub>VIN</sub>	V	
V <sub>IL</sub>	Low Level Input Voltage		0.0		0.54	V	
V <sub>IHFLASH</sub>	High Level Input Voltage	Pin STROBE. Pin TXMASK/TORCH for TxMask mode	0.7		V <sub>VIN</sub>	V	
V <sub>ILFLASH</sub>	Low Level Input Voltage	(ext_torch_on=01) <sup>4</sup>	0.0		0.54	V	
V <sub>OL</sub>	Low Level Output Voltage	pin SDA, I <sub>OL</sub> =3mA			0.3	V	
I <sub>LEAK</sub>	Leakage current	Pins SCL, SDA	-1.0	0.0	+1.0	µA	
I <sub>PD</sub>	Pulldown current to GND <sup>5</sup>	Pins TORCH, STROBE and TXMASK/TORCH		36		µA	
t <sub>DEBTORCH</sub>	TORCH debounce time		6.3	9	11.7	ms	
t <sub>TIMEOUT</sub>	SCL timeout	In indicator, assist or flash mode, if SCL is low longer than this timeout, the AS3643 automatically enters shutdown mode	35		100	ms	
<b>I<sup>2</sup>C mode timings - see Figure 3 on page 7</b>							
f <sub>SCLK</sub>	SCL Clock Frequency			1/ t <sub>TIMEOUT</sub>	400	kHz	
t <sub>BUF</sub>	Bus Free Time Between a STOP and START Condition		1.3			µs	
t <sub>HD:STA</sub>	Hold Time (Repeated) START Condition <sup>6</sup>		0.6			µs	

Table 4. Electrical Characteristics (Continued)

Symbol	Parameter	Condition	Min	Typ	Max	Unit
$t_{\text{LOW}}$	LOW Period of SCL Clock		1.3			$\mu\text{s}$
$t_{\text{HIGH}}$	HIGH Period of SCL Clock		0.6			$\mu\text{s}$
$t_{\text{SU:STA}}$	Setup Time for a Repeated START Condition		0.6			$\mu\text{s}$
$t_{\text{HD:DAT}}$	Data Hold Time <sup>7</sup>		0		0.9	$\mu\text{s}$
$t_{\text{SU:DAT}}$	Data Setup Time <sup>8</sup>		100			ns
$t_{\text{R}}$	Rise Time of Both SDA and SCL Signals		$20 + 0.1C_{\text{B}}$		300	ns
$t_{\text{F}}$	Fall Time of Both SDA and SCL Signals		$20 + 0.1C_{\text{B}}$		300	ns
$t_{\text{SU:STO}}$	Setup Time for STOP Condition		0.6			$\mu\text{s}$
$C_{\text{B}}$	Capacitive Load for Each Bus Line	$C_{\text{B}}$ — total capacitance of one bus line in pF			400	pF
$C_{\text{I/O}}$	I/O Capacitance (SDA, SCL)				10	pF

1. For  $V_{\text{BAT}}=4.5\text{V}$ ,  $SCL=1.8\text{V}$ ,  $SDA=1.8\text{V}$  maximum  $I_{\text{STANBY}}$  is  $<16\mu\text{A}$ .
2. To improve efficiency at low output currents, the active part of the internal switching transistor PMOS is reduced in size to 1/5 its original size. This reduces the current required to drive the PMOS transistor and therefore improves overall efficiency at low output currents.
3. Due to slope compensation of the current limit,  $I_{\text{LIMIT}}$  changes with duty cycle.
4. The logic input levels  $V_{\text{IH}}$  and  $V_{\text{IL}}$  allow for 1.2V or 1.8V supplied driving circuit
5. A pulldown current of  $36\mu\text{A}$  is equal to a pulldown resistor of  $42\text{k}\Omega$  at 1.5V
6. After this period, the first clock pulse is generated.
7. A device must internally provide a hold time of at least 300ns for the SDA signal (referred to the  $V_{\text{IHMIN}}$  of the SCL signal) to bridge the undefined region of the falling edge of SCL.
8. A fast-mode device can be used in a standard-mode system, but the requirement  $t_{\text{SU:DAT}} =$  to 250ns must then be met. This is automatically the case if the device does not stretch the LOW period of the SCL signal. If such a device does stretch the LOW period of the SCL signal, it must output the next data bit to the SDA line  $t_{\text{R max}} + t_{\text{SU:DAT}} = 1000 + 250 = 1250\text{ns}$  before the SCL line is released.

## Timing Diagrams

Figure 3. I<sup>2</sup>C mode Timing Diagram

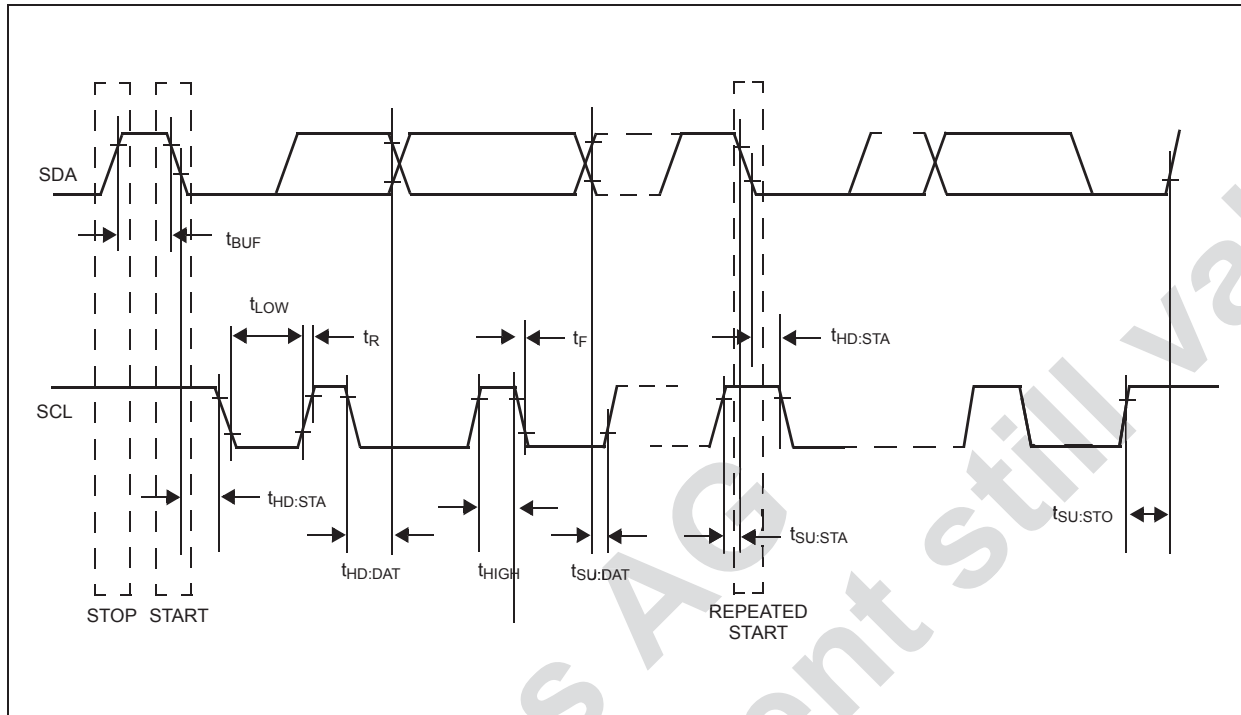

## 7 Typical Operating Characteristics

$V_{IN} = 3.7V$ ,  $T_A = +25^{\circ}C$  (unless otherwise specified), LED: Osram Phaser 2 ( $V_{FLED}=3.8V$  at 1A)

Figure 4. DCDC Efficiency vs.  $V_{IN}$

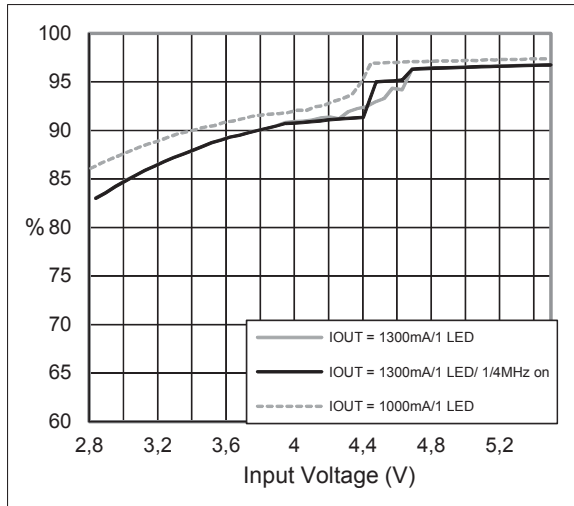

Figure 5. Application Efficiency ( $P_{LED}/P_{VIN}$ ) vs.  $V_{IN}$

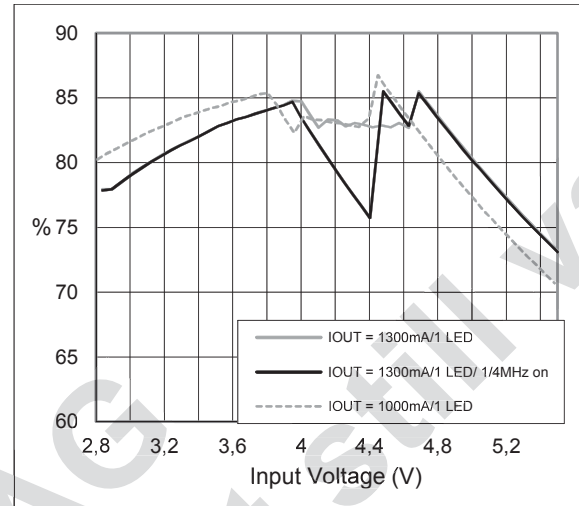

Figure 6. Battery Current vs.  $V_{IN}$

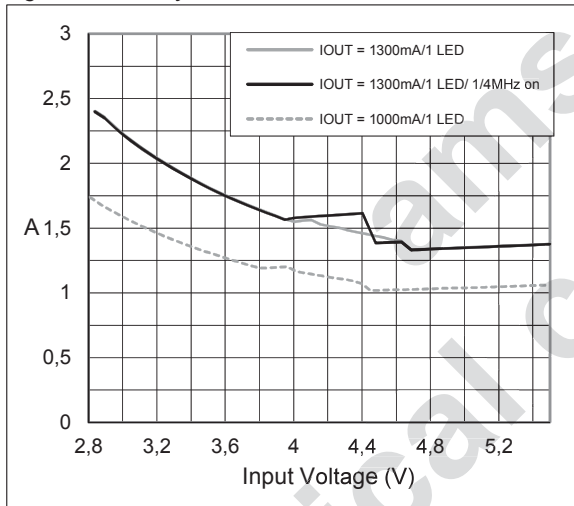

Figure 7. Efficiency at low currents (300mA)

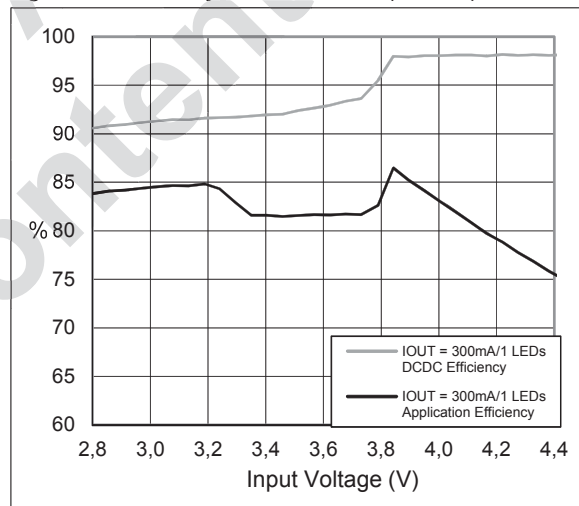

Figure 8.  $I_{LED}$  Startup ( $I_{LED\_OUT}=1.0A$ )

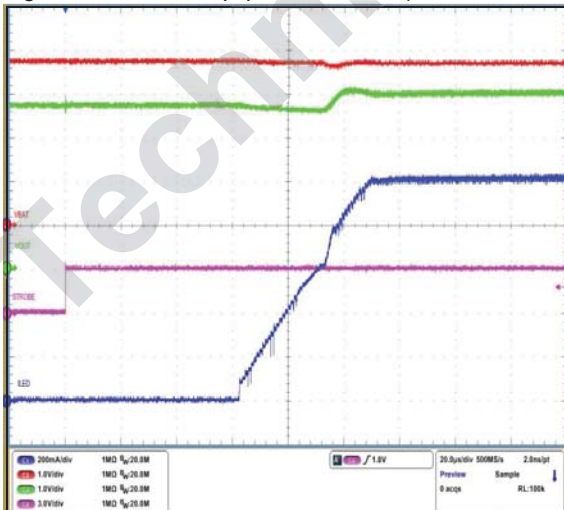

Figure 9.  $I_{VIN}$ ,  $I_{LED}$  Startup ( $I_{LED\_OUT}=800mA$ )

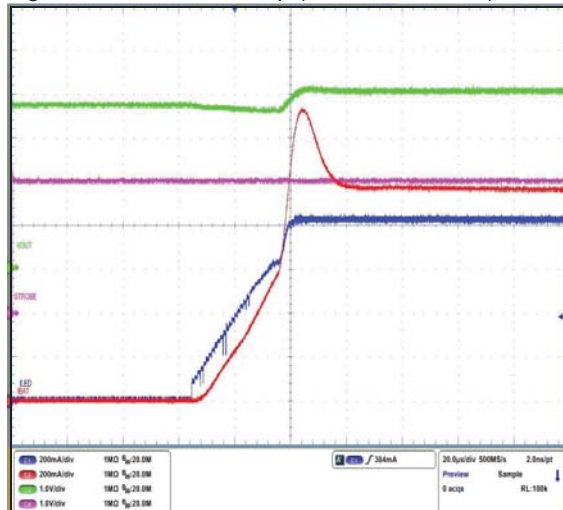

Figure 10. ILED Startup (ILED\_OUT=60mA)

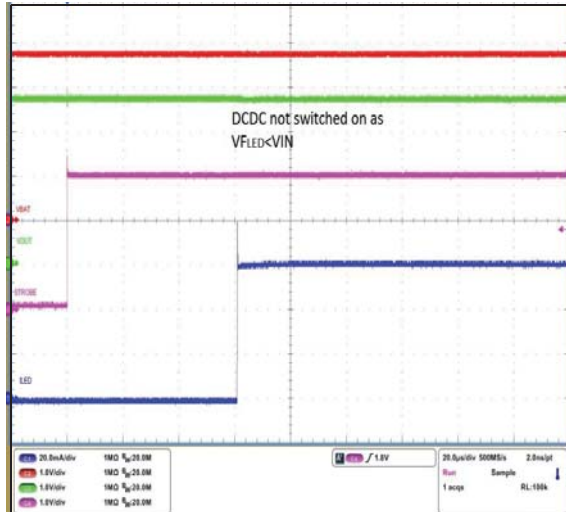

Figure 11. VOUT / ILED\_OUT ripple, ILED\_OUT = 1.0A

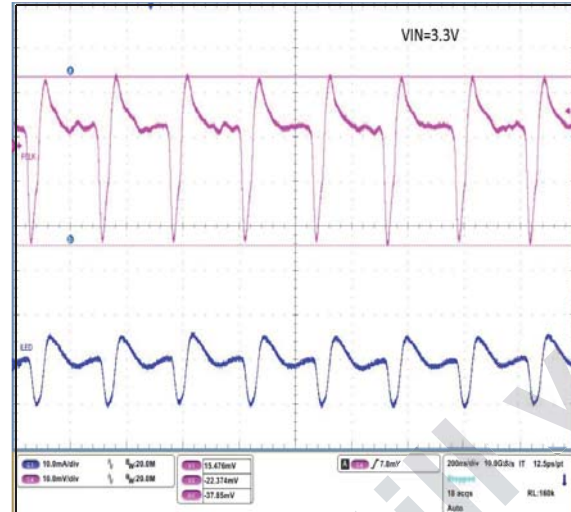

Figure 12. ILED Rampdown (ILED\_OUT=1.0A)

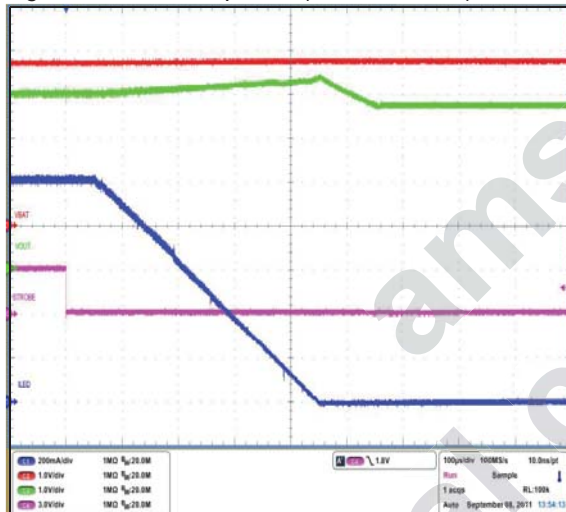

Figure 13. ILED\_OUT vs. TAMB

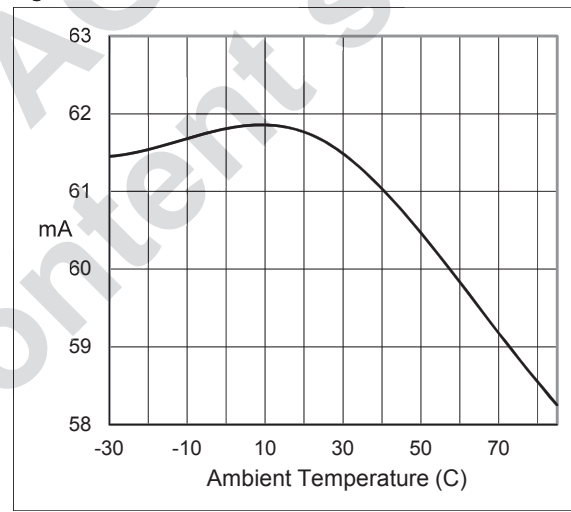

Figure 14. Oscillator frequency fCLK vs. TAMB

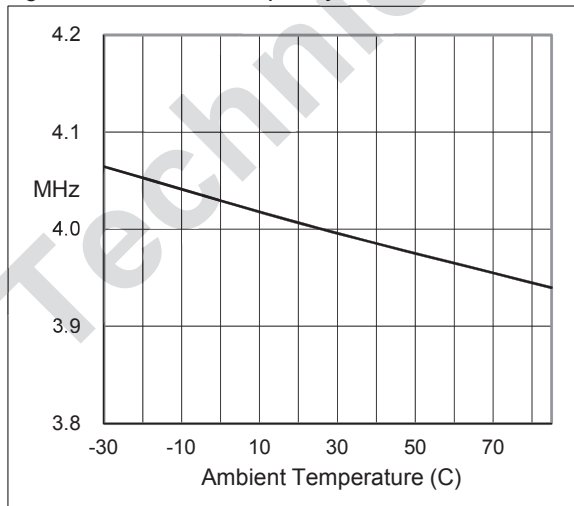
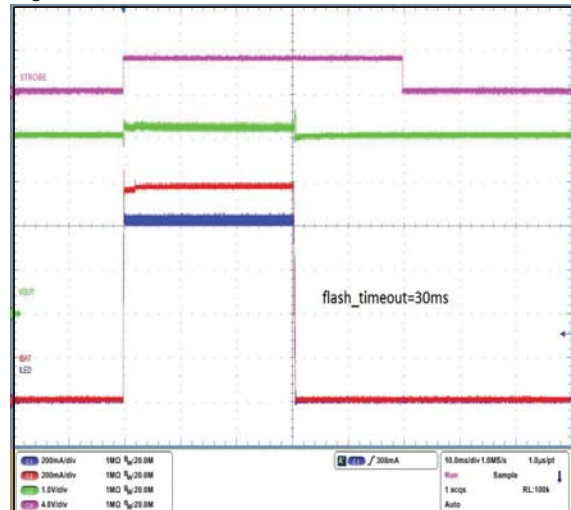

Figure 15. Flash Timeout



## 8 Detailed Description

The AS3643 is a high performance DCDC step up converter with internal PMOS and NMOS switches. Its output is connected to one flash LED with an internal current sink. The device is controlled by the pins SDA and SCL in I<sup>2</sup>C mode.

The actual operating mode like standby, assist light, indicator or flash mode, can then be chosen by the interface. If not in standby mode, the device automatically enters shutdown mode by keeping SCL low for more than  $t_{TIMEOUT}^1$ .

The AS3643 includes a fixed frequency DCDC step-up with accurate startup control. Together with the current sink (on LED\_OUT1/2) it includes several protection and safety functions.

### Internal Circuit Diagram

Figure 16. Internal circuit Diagram

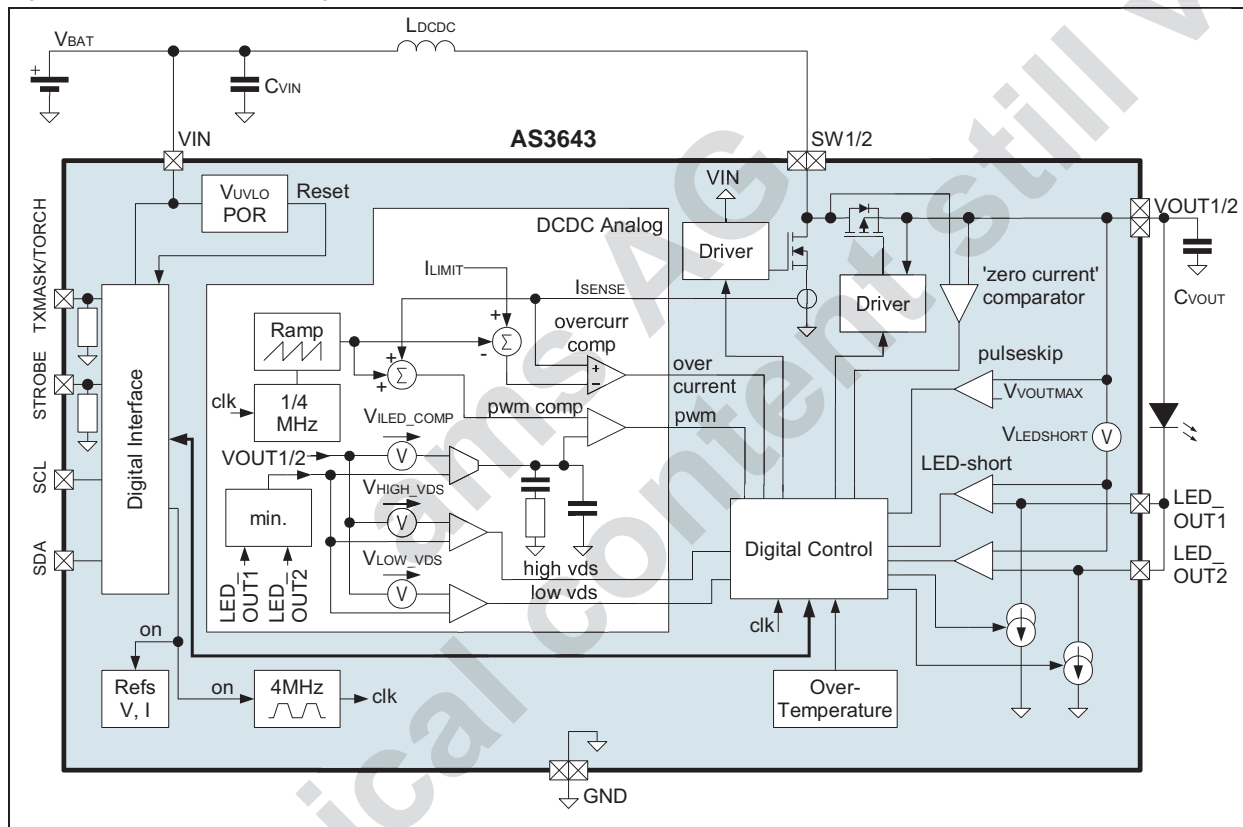

### Softstart / Soft ramp down

During startup and ramp down the LED current is smoothly ramped up and ramped down. If the DCDC converter goes out of regulation (measured by monitoring the voltage across the current sinks), the ramp up is temporarily stopped in order for the DCDC to return to regulation<sup>2</sup>.

1. Following registers are reset to their default value if the timeout expires: `out_on=0`, `ext_torch_on=00`, `mode_setting=00`, `const_v_mode=0`.
2. The actual value of the LED current setting can be readout by the register `led_current_actual` (see page 26) to allow the camera processor to adopt to the actual operating conditions.

## 4MHz/1MHz Operating Mode Switching

If `freq_switch_on` (see page 26)=1 and in flash and assist light mode (indicator mode or low current mode using PWM mode -see `mode_setting` (page 24) - always will use pulseskip) if `led_current`>=40h, the DCDC converter always operates in PWM mode (exception: PFM mode is allowed during startup) to reduce EMI in EMI sensitive systems. For flash and assist light mode and high duty cycles close to 100% on-time (maximum duty cycle) of the PMOS, the DCDC converter can switch into a 1MHz operating mode and maximum duty cycle to improve efficiency for this load condition<sup>3</sup>. The DCDC converter returns back to its normal 4MHz operating frequency when load or supply conditions change. Due to this switching between two fixed frequencies the noise spectrum of the system is exactly defined and predictable. If improved efficiency is required, the fixed switching between 1MHz / 4MHz can be disabled by `freq_switch_on` (see page 26)=0. In this case pulseskip will be used.

The internal circuit for switching between these two frequencies is shown in Figure 17:

Figure 17. Internal circuit of 4MHz/1MHz selection

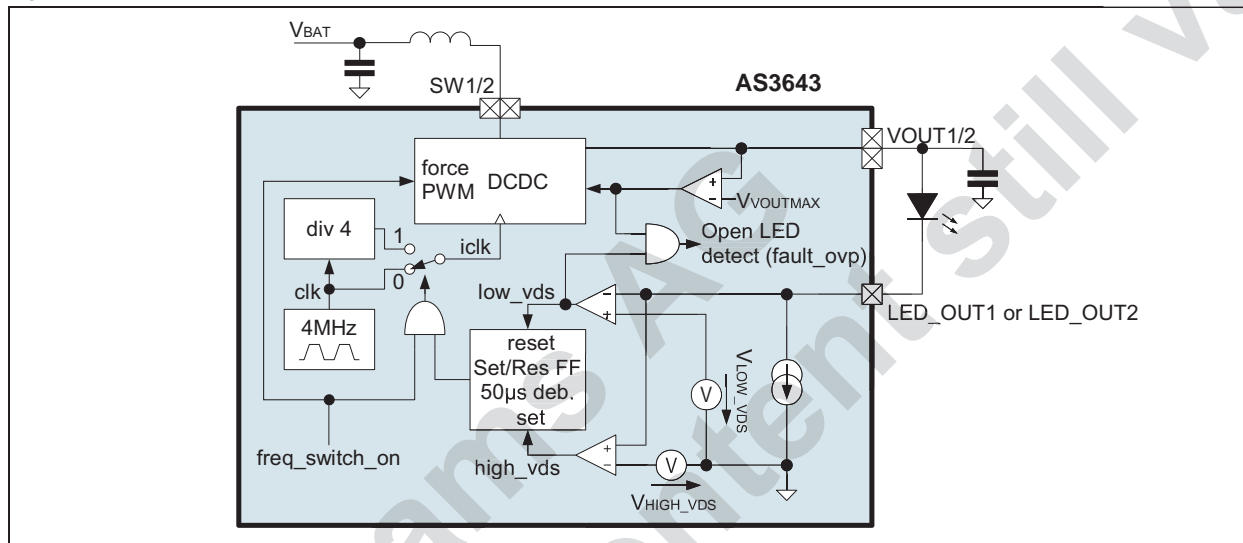

**Note:** For simplicity Figure 17 shows only a single current sink.

## Protection and Fault Detection Functions

The protection functions protect the AS3643 and the LED(s) against physical damage. In most cases a `Fault` register bit is set, which can be readout by the I<sup>2</sup>C interface. The fault bits are automatically cleared by a I<sup>2</sup>C readout of the fault register. Additionally the DCDC is stopped and the current sinks are disabled<sup>4</sup> by resetting `out_on`=0, `mode_setting`=00 and `ext_torch_on`=00.

### Overvoltage Protection

In case of no or a broken LED(s) at the pin LED\_OUT1/2 and an enabled DCDC converter, the voltage on VOUT1/2 rises until it reaches  $V_{VOUTMAX}$  (overvoltage condition) and the voltage across the current source is below  $low\_vds$ <sup>5</sup>, the DCDC converter is stopped, the current sources are disabled and the bit `fault_ovp` (see page 25) is set<sup>6</sup>.

3. Efficiency compared to a 4MHz only DCDC converter forced to operate with minimum duty cycle.
4. Applies for all faults except `TXMASK event occurred`
5. If overvoltage is reached, but none of the `low_vds` comparator(s) triggers, VOUT1/2 is still regulated below  $V_{VOUTMAX}$ .
6. In constant voltage mode (5V generation, register bit `const_v_mode`=1) this fault is disabled.

### Short Circuit Protection

After the startup of the DCDC converter, the voltage on LED\_OUT1/2 is continuously monitored and compared against  $V_{LED\_SHORT}$  if the LED current is above 20mA<sup>7</sup> (see Figure 18). If the voltage across the LED ( $V_{FLED} = V_{OUT1/2}$ -LED\_OUT1/2) stays below  $V_{LED\_SHORT}$ , the DCDC is stopped (as a shorted LED is assumed), the current sinks are disabled and the bit `fault_led_short` (see page 25) is set.

Figure 18. Short LED detection

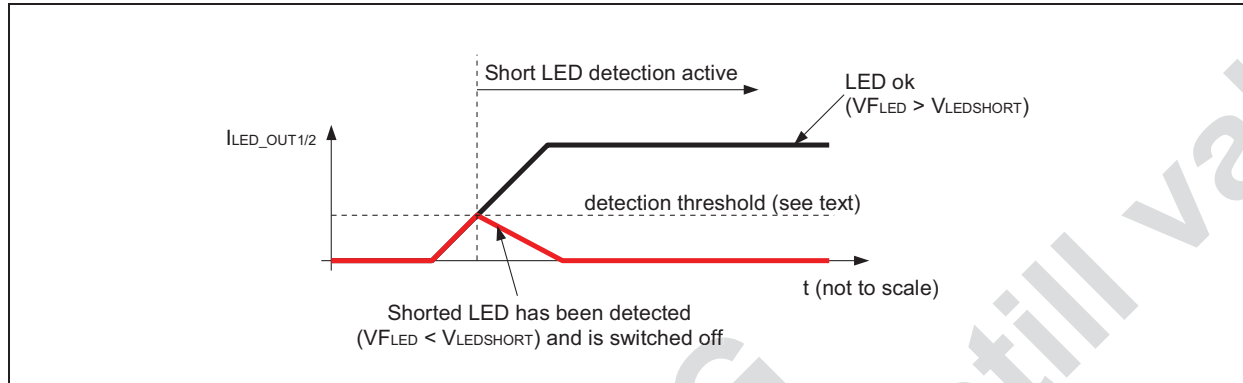

### Overtemperature Protection

The junction temperature of the AS3643 is continuously monitored. If the temperature exceeds  $T_{OVTEMP}$ , the DCDC is stopped, the current sinks are disabled (instantaneous) and the bit `fault_overtemp` (see page 25) is set. The driver is automatically re-enabled<sup>8</sup> once the junction temperature drops below  $T_{OVTEMP}-T_{OVTEMPHYST}$ .

### TXMASK event occurred

If during flash, TXMASK current reduction is enabled (see TXMASK on page 15, configured by `ext_torch_on=01`) and a TXMASK event happened (pin TXMASK/TORCH=1), the fault register bit `fault_txmask` (see page 25) is set.

### Flash Timeout

If the flash is started a timeout timer is started in parallel. If the flash duration defined by the STROBE input (`strobe_on = 1` and `strobe_type = 1`, see Figure 25 on page 17) exceeds  $t_{FLASH\_TIMEOUT}$  (adjustable by register `flash_timeout` (see page 24)), the DCDC is stopped and the flash current sinks (on pin LED\_OUT1/2) are disabled and `fault_timeout` is set.

If the flash duration is defined by the timeout timer itself (`strobe_on = 0`, see Figure 23 on page 17), the register `fault_timeout` is set after the flash has been finished.

### Supply undervoltage Protection

If the voltage on the pin VIN (=battery voltage) is or falls below  $V_{UVLO}$ , the AS3643 is kept in shutdown state and all registers are set to their default state.

### Wakeup Circuit - Power off detection

In flash, assist light and indicator mode (register `mode_setting` (page 24)=01, 10 or 11) and `out_on` (page 24)=1, if SCL is L for more than  $t_{TIMEOUT}$ , shutdown mode is automatically entered. This feature automatically detects a power-off of the controlling circuit driving SCL and SDA ( $V_{DD\_I/F}$  goes to 0V e.g. due to a low power condition of the driving circuit) - the internal circuit is shown in Figure 19:

7. To avoid errors in short LED detection for LEDs with a high leakage current

8. In constant voltage mode (`const_v_mode=1`) the DCDC will not be automatically re-enabled.

Figure 19. Device Shutdown and Wakeup

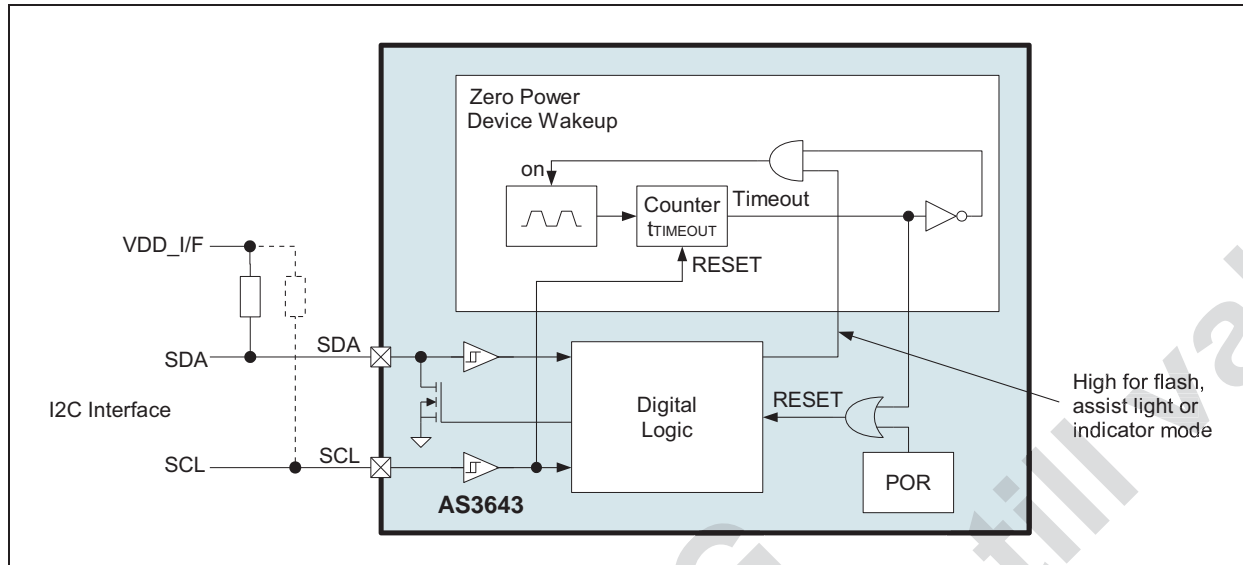

In shutdown mode once pin SCL goes high for the first time, the internal counter shown in Figure 19 is immediately reset thus releasing the internal RESET (assuming VIN is above  $V_{UVLO}$ ) signal and allows instant communication on the I<sup>2</sup>C bus. Therefore no additional action is required to leave the shutdown mode and start I<sup>2</sup>C communication.

#### Purpose of this circuit

The purpose of this circuit is an additional security mechanism.

Assume the user programmed torch or indicator operation (there is no timeout for these operating modes) and the battery slowly drops below the undervoltage limit of the system. The processor would get a reset by the PMIC and the LDO operating VDD\_I/F is switched off, but the processor might not have been able to switch-off the torch/indicator operation of the AS3643. Due to the implemented security mechanism the AS3643 detects a power off of VDD\_I/F and automatically enters shutdown.

#### Current consumption in standby/shutdown mode

The AS3643 is designed to draw minimum current in standby and shutdown mode. There is a small difference in current consumption between these two operating modes (typ. 300nA) only due to the internal level shifters (see the schmitt trigger input buffers connected to SCL and SDA in Figure 19) for shifting up the voltage on SCL/SDA (VDD\_I/F e.g. 1.8V) to the supply voltage on VIN (e.g. 3.7V). If the AS3643 is driven with digital levels close to 0V/VIN, the current consumption for standby mode is identical to shutdown mode.

## Operating Mode and Currents

The output currents and operating mode are selected according to the following table:

Table 5. Operating Mode and current settings

AS3643 configuration					operating mode and currents		
SCL and SDA	TORCH	STROBE	mode_setting (see page 24)	out_on (see page 24)	Condition	Mode	LED_OUT1/2 output current  Always write same content to register <b>Current Set1 (led_current)</b> and <b>Current Set2</b>
SCL low for tTIMEOUT <sup>1</sup>	X	X	X	X	if previous operating mode was indicator, assist light or flash mode	shutdown all registers are reset to their default values	0
I <sup>2</sup> C commands are accepted	X	X	10, 01 or 11	0		standby	0
	X	X	00	X	ext_torch_on (see page 22) not 10		
	0	X			ext_torch_on = 10		
	1	X	ext_torch_on = 10	external torch mode	LED current is defined by the 7LSB <sup>2</sup> bits of <b>led_current</b> and <b>led_current2</b>		
	X	X	01	1	indicator mode or low current pwm mode <sup>3</sup>	LED current is defined by the 6LSB bits (bits 5...0) of <b>led_current</b> and <b>led_current2</b> pwm modulated with 31.25kHz defined by register <b>inct_pwm</b> (1/16...4/16)	
	X	X	10	1	assist light mode	LED current is defined by the 7LSB <sup>2</sup> bits (6...0) of <b>led_current</b> and <b>led_current2</b>	
	X	X	11	1	strobe_on (see page 25) = 0	flash mode;	LED current is defined by <b>led_current</b> and <b>led_current2</b> - the current can be reduced during flash, see <b>Flash Current Reductions</b> below
	X	0->1			strobe_on = 1 and strobe_type (see page 25) = 0	flash duration defined by <b>flash_timeout</b> (see page 24)	
X	1	strobe_on = 1 and strobe_type = 1			flash duration defined by STROBE input; timeout defined by <b>flash_timeout</b>		

1. SCL low for tTIMEOUT and operating mode is indicator, assist or flash mode then shutdown mode is entered.
2. The MSB bit of this register not used to protect the LED; therefore the maximum assist / torch light current = half the maximum flash current
3. The low current mode is a general purpose PWM mode to drive less current through the LED in average, but keep the actual pulsed current in a range where the light output from the LED is still specified. As only the 6 LSBs of **led\_current** are used the maximum current is limited to 1/4 of the maximum flash current.

## Flash Current Reductions

### TXMASK

Usually the flash current is defined by the register `led_current`. If the TXMASK/TORCH input is used and (configured by `ext_torch_on=01`), the flash current is reduced to `flash_txmask_current` if TXMASK/TORCH=1.

### Current Reduction by VIN measurements in Flash Mode

Due to the high load of the flash driver and the ESR of the battery (especially critical at low temperatures), the voltage on the battery drops. If the voltage drops below the reset threshold of the system would reset. To prevent this condition the AS3643 monitors the battery voltage and keeps it above `vin_low_v_run` as follows:

Before a flash is started the voltage on VIN is measured. If the voltage is below the setting of `vin_low_v` the `fault_uvlo` (see page 25) is set and the flash is disabled (driver stays in shutdown) if `vin_low_v_shutdown=1`. The flash current is reduced to `flash_txmask_current` if `vin_low_v_shutdown=0`.

During flash, if the voltage on VIN drops below the threshold defined by `vin_low_v_run`, the flash current is reduced (or ramping of the current is stopped during flash current startup) and `fault_uvlo` is set. The timing for the reduction of the current is  $8\mu\text{s}/\text{LSB}$  current change.

During the flash pulse the actual used current can be readout by the register `led_current_actual`.

After the flash pulse the minimum current can be readout by the register `led_current_min` - this allows to adjust the camera sensitivity (gain or iso-settings) for the subsequent flash pulse (e.g. when using a pre-flash and a main flash pulse).

The internal circuit for low voltage current reductions are shown in Figure 20:

Figure 20. Low Voltage current Reduction Internal Circuit

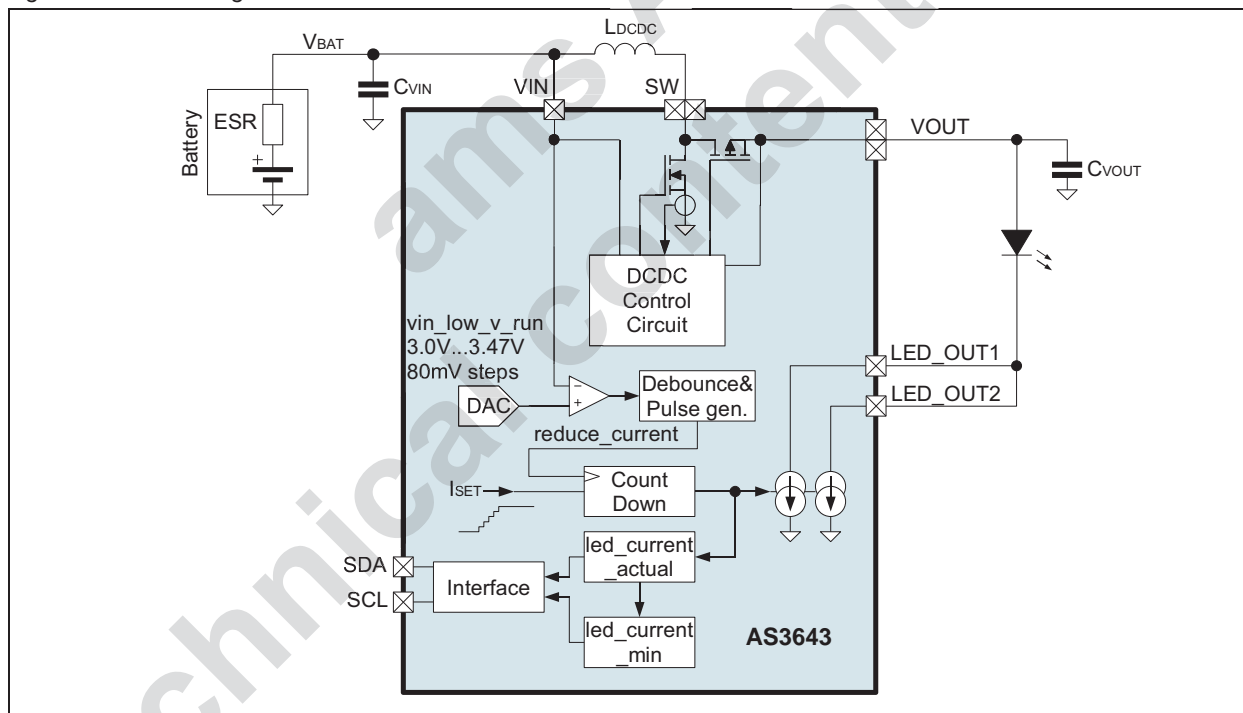

A mobile phone camera flash system can trigger a diagnostic flash and a main-flash:

The diagnostic flash is initiated by the processor. After this diagnostic flash, the determined maximum flash current can be read back through the I<sup>2</sup>C interface from register `led_current_min` (see page 26) and used for the setting for the main flash. Therefore the current in the main-flash is constant and additionally the camera system can use this current for picture quality adjustments - the waveforms for this concept are shown in Figure 21:

Figure 21. Low Voltage current Reduction Waveform with diagnostic-Flash and Main-Flash Phase

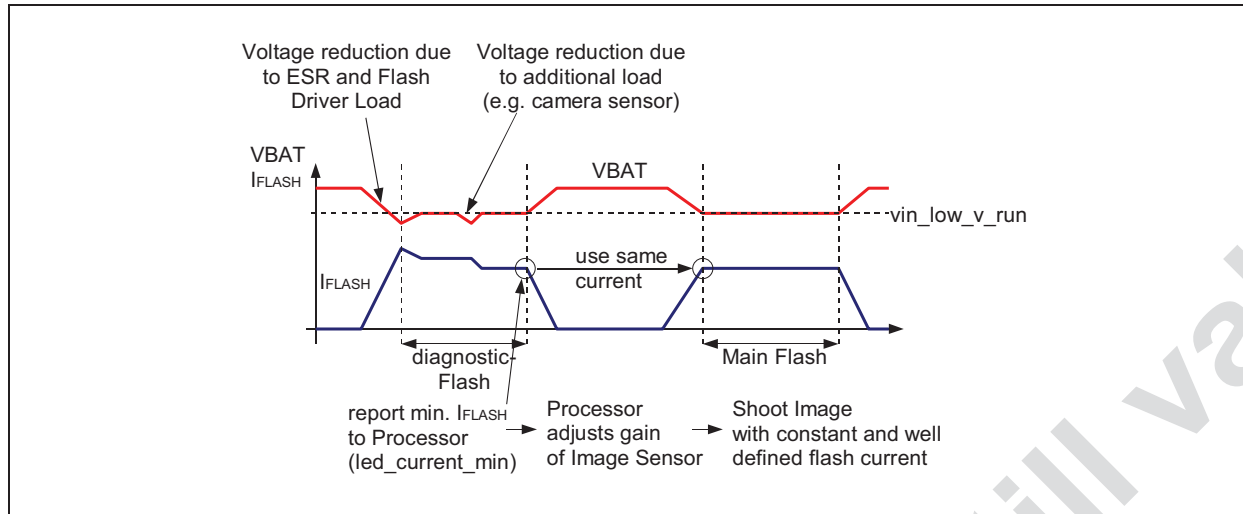

If the diagnostic flash should be short (e.g. 10ms) it is recommended to operate this diagnostic flash at slightly higher `vin_low_v_run` setting compared to the main flash as shown in Figure 22:

Figure 22. Low Voltage current Reduction Waveform with short diagnostic-Flash and Main-Flash Phase

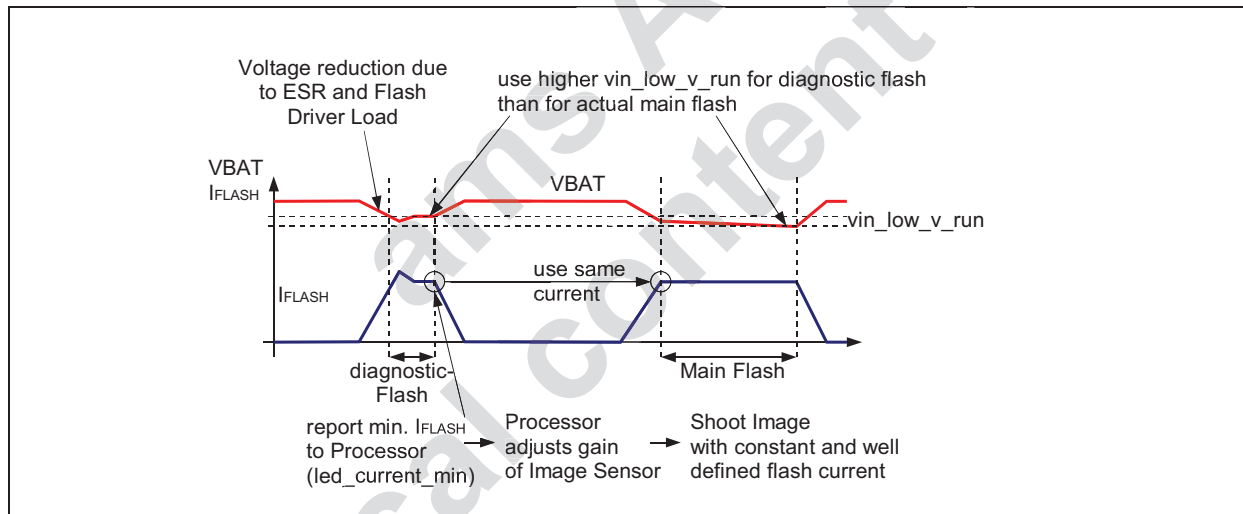

The different settings for `vin_low_v_run` allow a constant main flash current without dropping VIN below `vin_low_v_run`.

## Flash Strobe Timings

The flash timing are defined as follows:

- Flash duration defined by register `flash_timeout` and flash is started immediately when this mode is selected by the I<sup>2</sup>C command (see Figure 23):  
set `strobe_on` = 0, start the flash by setting `out_on` = 1
- Flash duration defined by register `flash_timeout` and flash started with a rising edge on pin STROBE (see Figure 24):  
set `strobe_on` = 1 and `strobe_type` = 0
- Flash start and timing defined by the pin STROBE; the flash duration is limited by the timeout timer defined by `flash_timeout` (see Figure 25 and Figure 26):  
set `strobe_on` = 1 and `strobe_type` = 1

Figure 23. AS3643 flash duration defined by *flash\_timeout* without using STROBE input

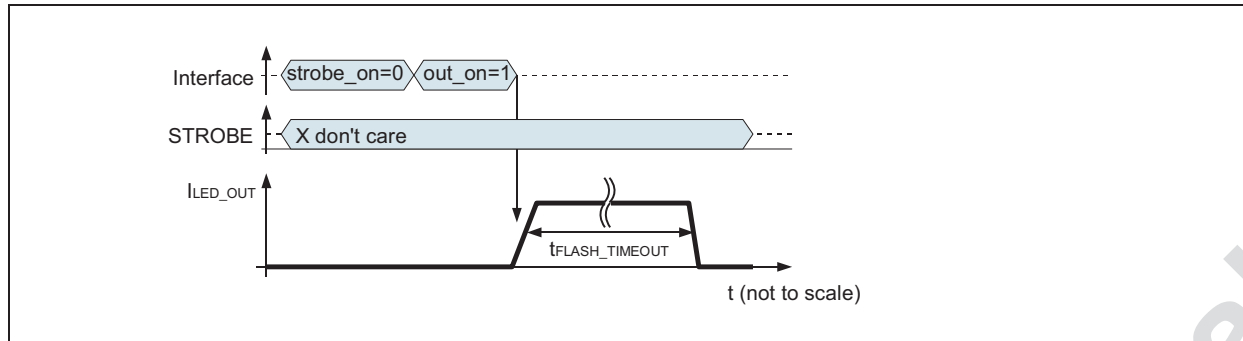

Figure 24. AS3643 flash duration defined by *flash\_timeout*, starting flash with STROBE rising edge

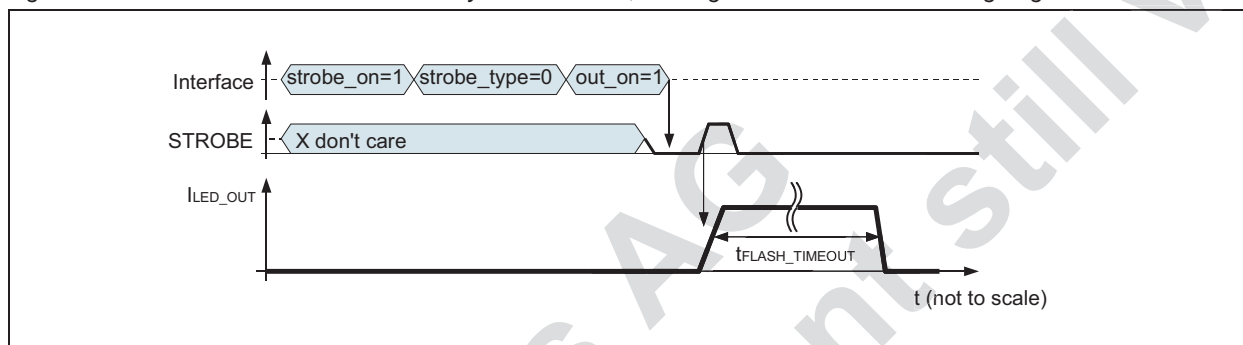

Figure 25. AS3643 flash duration and start defined by STROBE, limited by *flash\_timeout*; timer not expired

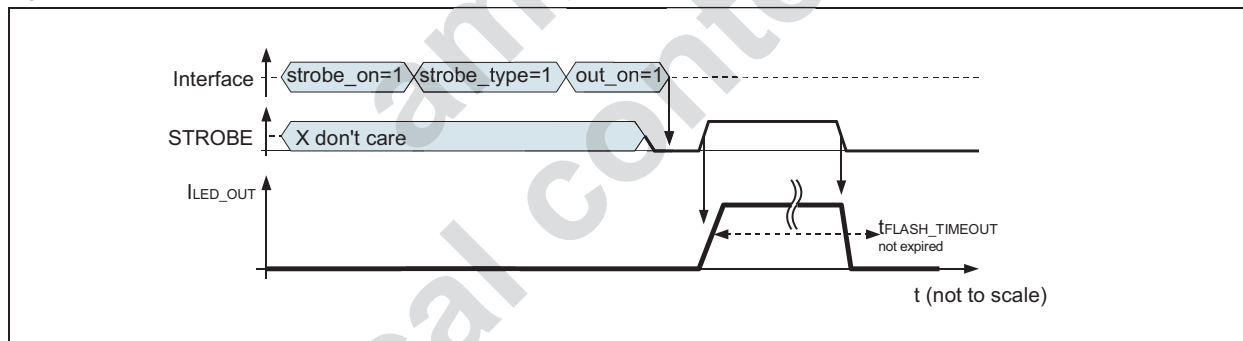
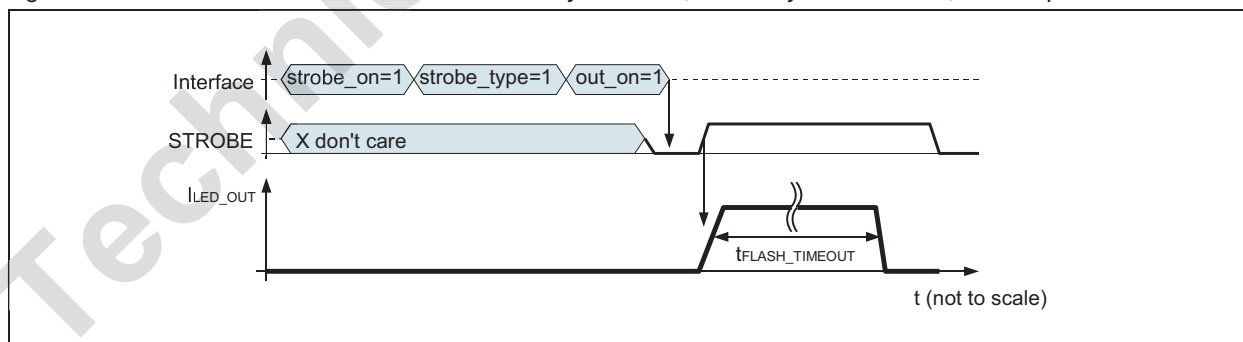

Figure 26. AS3643 flash duration and start defined by STROBE, limited by *flash\_timeout*; timer expired



## I<sup>2</sup>C Serial Data Bus

The AS3643 supports the I<sup>2</sup>C bus protocol. A device that sends data onto the bus is defined as a transmitter and a device receiving data as a receiver. The device that controls the message is called a master. The devices that are controlled by the master are referred to as slaves. A master device that generates the serial clock (SCL), controls the bus access, and generates the START and STOP conditions must control the bus. The AS3643 operates as a slave on the I<sup>2</sup>C bus. Within the bus specifications a standard mode (100kHz maximum clock rate) and a fast mode (400kHz maximum clock rate) are defined. The AS3643 works in both modes. Connections to the bus are made through the open-drain I/O lines SDA and SCL.

The following bus protocol has been defined (Figure 27):

- Data transfer may be initiated only when the bus is not busy.
- During data transfer, the data line must remain stable whenever the clock line is HIGH. Changes in the data line while the clock line is HIGH are interpreted as control signals.

Accordingly, the following bus conditions have been defined:

### *Bus Not Busy*

Both data and clock lines remain HIGH.

### *Start Data Transfer*

A change in the state of the data line, from HIGH to LOW, while the clock is HIGH, defines a START condition.

### *Stop Data Transfer*

A change in the state of the data line, from LOW to HIGH, while the clock line is HIGH, defines the STOP condition.

### *Data Valid*

The state of the data line represents valid data when, after a START condition, the data line is stable for the duration of the HIGH period of the clock signal. The data on the line must be changed during the LOW period of the clock signal. There is one clock pulse per bit of data.

Each data transfer is initiated with a START condition and terminated with a STOP condition. The number of data bytes transferred between START and STOP conditions are not limited, and are determined by the master device. The information is transferred byte-wise and each receiver acknowledges with a ninth bit.

### *Acknowledge*

Each receiving device, when addressed, is obliged to generate an acknowledge after the reception of each byte. The master device must generate an extra clock pulse that is associated with this acknowledge bit.

A device that acknowledges must pull down the SDA line during the acknowledge clock pulse in such a way that the SDA line is stable LOW during the HIGH period of the acknowledge-related clock pulse. Of course, setup and hold times must be taken into account. A master must signal an end of data to the slave by not generating an acknowledge bit on the last byte that has been clocked out of the slave. In this case, the slave must leave the data line HIGH to enable the master to generate the STOP condition.

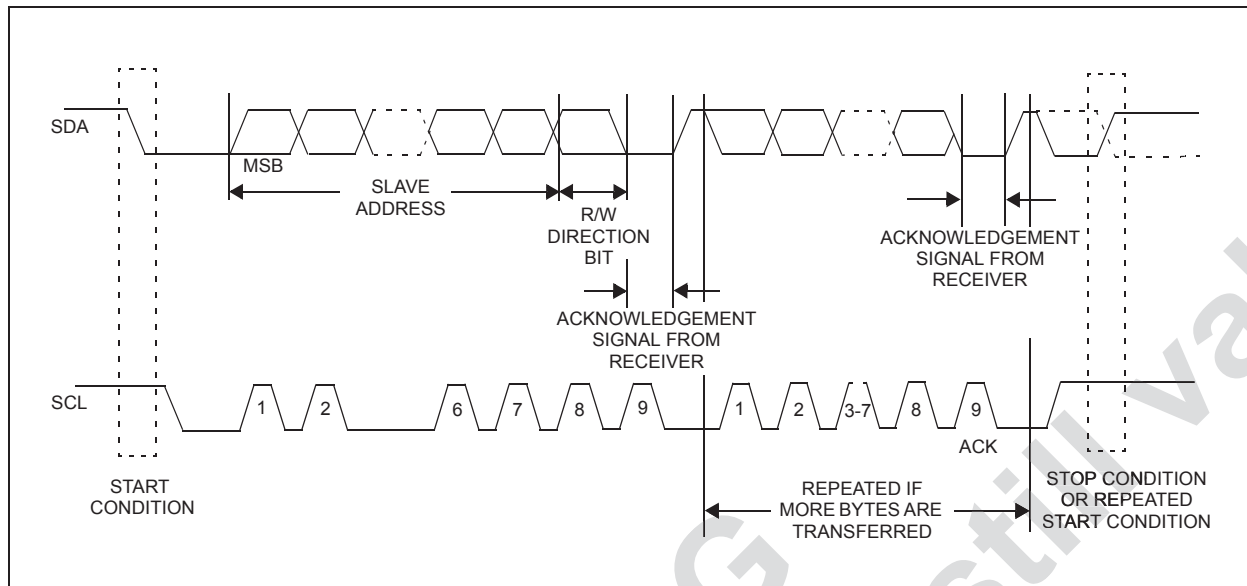
Figure 27. Data Transfer on I<sup>2</sup>C Serial Bus

Depending upon the state of the R/W bit, two types of data transfer are possible:

1. **Data transfer from a master transmitter to a slave receiver.** The first byte transmitted by the master is the slave address. Next follows a number of data bytes. The slave returns an acknowledge bit after each received byte. Data is transferred with the most significant bit (MSB) first.
2. **Data transfer from a slave transmitter to a master receiver.** The master transmits the first byte (the slave address). The slave then returns an acknowledge bit, followed by the slave transmitting a number of data bytes. The master returns an acknowledge bit after all received bytes other than the last byte. At the end of the last received byte, a "not acknowledge" is returned. The master device generates all of the serial clock pulses and the START and STOP conditions. A transfer is ended with a STOP condition or with a repeated START condition. Since a repeated START condition is also the beginning of the next serial transfer, the bus is not released. Data is transferred with the most significant bit (MSB) first.

The AS3643 can operate in the following two modes:

1. **Slave Receiver Mode (Write Mode):** Serial data and clock are received through SDA and SCL. After each byte is received an acknowledge bit is transmitted. START and STOP conditions are recognized as the beginning and end of a serial transfer. Address recognition is performed by hardware after reception of the slave address and direction bit (see Figure 28). The slave address byte is the first byte received after the master generates the START condition. The slave address byte contains the 7-bit AS3643 address, which is 0110000, followed by the direction bit (R/W), which, for a write, is 0.<sup>9</sup> After receiving and decoding the slave address byte the device outputs an acknowledge on the SDA line. After the AS3643 acknowledges the slave address + write bit, the master transmits a register address to the AS3643. This sets the register pointer on the AS3643. The master may then transmit zero or more bytes of data, with the AS3643 acknowledging each byte received. The address pointer will increment after each data byte is transferred. The master generates a STOP condition to terminate the data write.
2. **Slave Transmitter Mode (Read Mode):** The first byte is received and handled as in the slave receiver mode. However, in this mode, the direction bit indicates that the transfer direction is reversed. Serial data is transmitted on SDA by the AS3643 while the serial clock is input on SCL. START and STOP conditions are recognized as the beginning and end of a serial transfer (Figure 29 and Figure 30). The slave address byte is the first byte received after the master generates a START condition. The slave address byte contains the 7-bit AS3643 address, which is 0110000, followed by the direction bit (R/W), which, for a read, is 1.<sup>10</sup> After receiving and decoding the slave address byte the device outputs an acknowledge on the SDA line. The AS3643 then begins to transmit data starting with the register address pointed to by the register pointer. If the register

9. The address for writing to the AS3643 is 60h = 01100000b

10. The address for read mode from the AS3643 is 61h = 01100001b

pointer is not written to before the initiation of a read mode the first address that is read is the last one stored in the register pointer. The AS3643 must receive a “not acknowledge” to end a read.

Figure 28. Data Write - Slave Receiver Mode

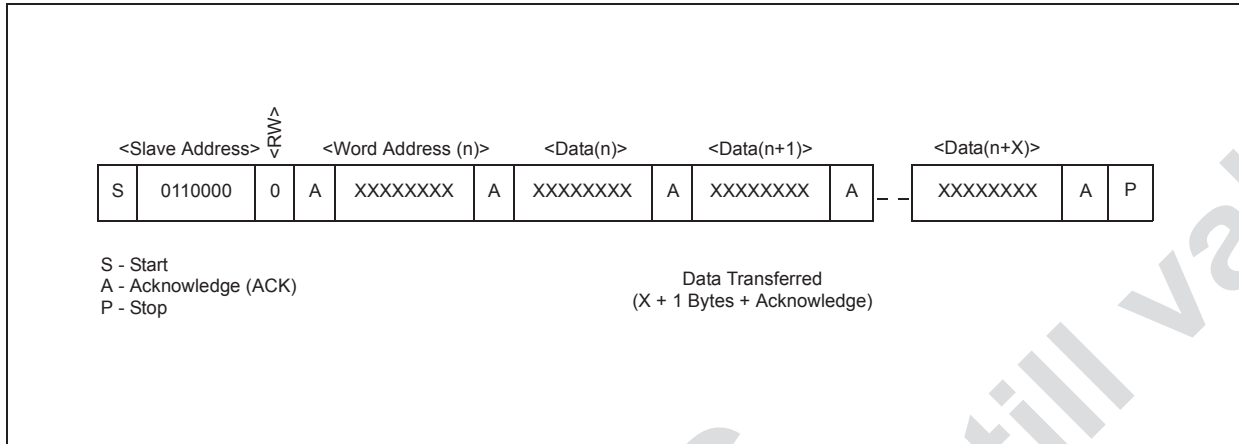

Figure 29. Data Read (from Current Pointer Location) - Slave Transmitter Mode

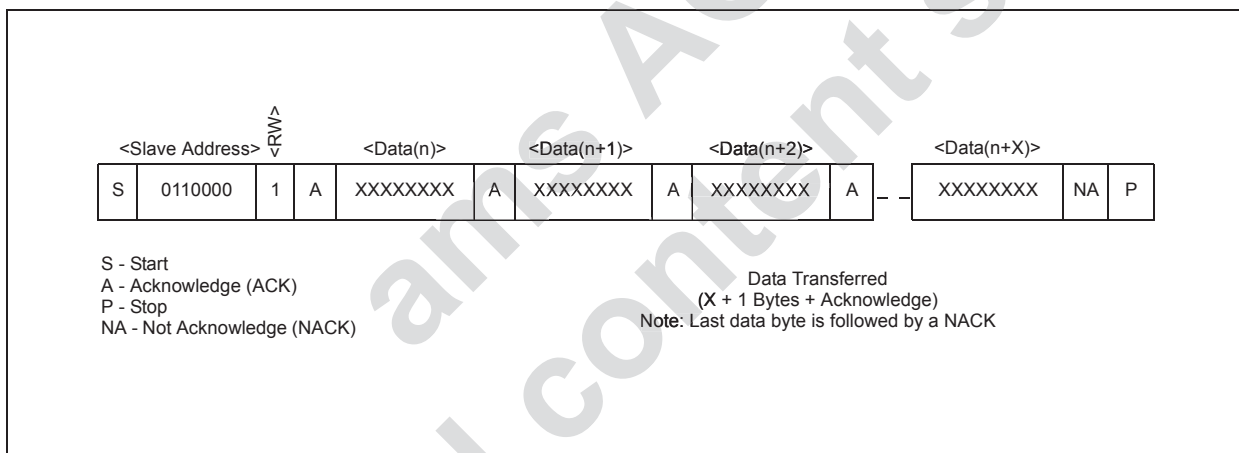
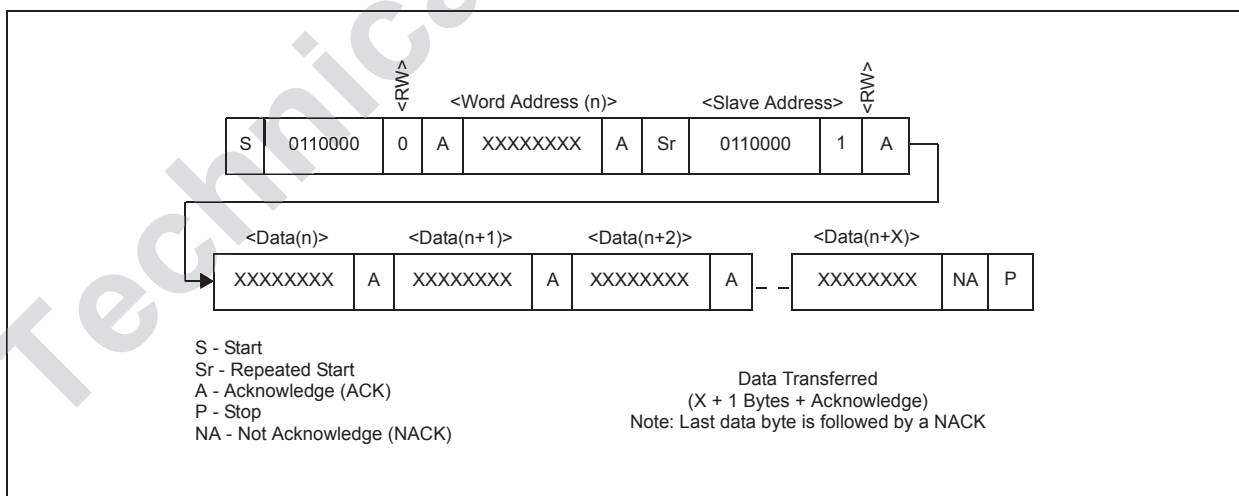

Figure 30. Data Read (Write Pointer, Then Read) - Slave Receive and Transmit



## Register Description

Table 6. *ChipID Register*

Addr: 0		ChipID Register		
		This register has a fixed ID		
Bit	Bit Name	Default	Access	Description
2:0	version	Xh	R	AS3643 chip version number
7:3	fixed_id	10110b	R	This is a fixed identification (e.g. to verify the I <sup>2</sup> C communication)

Table 7. *Current Set1 Register*

Addr: 1		Current Set1 Register			
		This register defines design versions			
Bit	Bit Name	Default	Access	Description	
7:0	led_current	9Ch	R/W	Define the current on pin LED_OUT1/2 (combined; each current sink has identical currents) assist mode uses bits 6:0 of this current setting (max. half of full current setting) indicator or low current pwm mode uses only 5:0 of this current setting (max. 1/4 of full current setting) <b>Caution:</b> Always write same content to this register Current Set1 (1h) and Current Set2 (2h)	
				0h	0mA
				1h	5.1mA
				2h	10.2mA
				...	...
				3Fh	321.2mA (maximum current for indicator or low current pwm mode, <a href="#">mode_setting=01</a> )
				...	...
				7Fh	647.5mA (maximum current for assist light mode, <a href="#">mode_setting=10</a> )
				...	...
				9Ch	795.3mA - default setting
				...	...
				FEh	1295mA
				FFh	1300mA

Table 9. TXMask Register

Addr: 3		TXMask Register			
This register defines the TXMask settings and coil peak current					
Bit	Bit Name	Default	Access	Description	
1:0	ext_torch_on	00	R/W	Defines operating mode for input pin TXMASK/TORCH	
				00	pin has no effect
				01	txmask-mode; during flash if TXMASK/TORCH=1, the LED current is set to flash_txmask_current - (see TXMASK on page 15)
				10	external torch mode: if TXMASK/TORCH=1 and mode_setting=00, the AS3643 is set into external torch mode (LED current is defined by the 7LSB <sup>1</sup> bits of led_current )
				11	don't use
3:2	coil_peak	10	R/W	Defines the maximum coil current (parameter I <sub>LIMIT</sub> )	
				00	I <sub>LIMIT</sub> = 1.0A
				01	I <sub>LIMIT</sub> = 1.5A
				10	I <sub>LIMIT</sub> = 2.0A
				11	I <sub>LIMIT</sub> = 2.5A
7:4	flash_txmask_current <sup>2</sup>	6h	R/W	Define the current on pin LED_OUT1/2 in flash mode if ext_torch_on=01 and TXMASK/TORCH=1	
				0h	0mA
				1h	82mA
				2h	163mA
				3h	245mA
				4h	326mA
				5h	408mA
				6h	489mA - default
				7h	571mA
				8h	653mA
				9h	734mA
				Ah	816mA
				Bh	897mA
				Ch	979mA
				Dh	1060mA
Eh	1142mA				
Fh	1224mA				

1. The MSB bit of this register not used to protect the LED; therefore the maximum current = half the maximum flash current

2.

Table 10. Low Voltage Register

Addr: 4		Low Voltage Register			
This register defines the operating mode with low battery voltages					
Bit	Bit Name	Default	Access	Description	
2:0	vin_low_v_run	4h	R/W	Voltage level on VIN where current reduction triggers during operation (see <a href="#">Current Reduction by VIN measurements in Flash Mode on page 15</a> ) - only in flash mode; if VIN drops below this voltage during current ramp up, the current ramp up is stopped; during operation the current is decreased until the voltage on VIN rises above this threshold - <a href="#">fault_uvlo</a> is set	
				0h	function is disabled
				1h	3.0V
				2h	3.07V
				3h	3.14V
				4h	3.22V - default
				5h	3.3V
				6h	3.38V
5:3	vin_low_v	5h	R/W	Voltage level on VIN where driver will change current before startup (only in flash mode) if before startup ( <a href="#">out_on</a> set from 0 to 1), the voltage on VIN is below <a href="#">vin_low_v</a> , the current is changed to <a href="#">flash_txmask_current</a> ( <a href="#">vin_low_v_shutdown</a> =0) or 0=shutdown ( <a href="#">vin_low_v_shutdown</a> =1) and <a href="#">fault_uvlo</a> is set	
				0h	function is disabled
				1h	3.0V
				2h	3.07V
				3h	3.14V
				4h	3.22V
				5h	3.3V - default
				6h	3.38V
6	vin_low_v_shutdown	0	R/W	Enables Shutdown of current reduction under low voltage conditions	
				0	if before startup ( <a href="#">out_on</a> set from 0 to 1), the voltage on VIN is below <a href="#">vin_low_v</a> , the current is changed to <a href="#">flash_txmask_current</a> and <a href="#">fault_uvlo</a> is set
7	const_v_mode	0	R/W	Enables Constant output voltage mode	
				0	Normal operation defined by <a href="#">mode_setting</a>
				1	5V constant voltage mode on VOUT1/2; reset registers <a href="#">mode_setting</a> , <a href="#">out_on</a> and <a href="#">ext_torch_on</a> before setting this bit

Table 11. Flash Timer Register

Addr: 5		Flash Timer Register			
This register identifies the flash timer and timeout settings					
Bit	Bit Name	Default	Access	Description	
7:0	flash_timeout	23h	R/W	Define the duration of the flash timer and timeout timer	
				0h	2ms
				1h	4ms
				2h	6ms
				...	...
				23h	72ms - default
				...	...
				7F	256ms
				80	264ms(now 8 ms LSB steps from here on) <sup>1</sup>
				81	272ms
				82	280ms
				...	...
				FEh	1272ms
FFh	1280ms				

1. Internal calculation for codes above 80h: flash timeout [ms] = (flash\_timeout-127) \* 8 + 256 [ms]

Table 12. Control Register

Addr: 6		Control Register			
This register identifies the operating mode and includes an all on/off bit					
Bit	Bit Name	Default	Access	Description	
1:0	mode_setting	00	R/W	Define the AS3643 operating mode	
				00	shutdown or external torch mode if <a href="#">ext_torch_on</a> (page 22)=10
				01	indicator mode (or low current mode using PWM) LED current is defined by the 6LSB bits of <a href="#">led_current</a> pwm modulated with 31.25kHz defined by register <a href="#">inct_pwm</a> (1/16..4/16)
				10	assist light mode: LED current is defined by the 7LSB <sup>1</sup> bits of <a href="#">led_current</a>
				11	flash mode: LED current is defined by <a href="#">led_current</a> ( <a href="#">out_on</a> and <a href="#">mode_setting</a> are automatically cleared after a flash pulse)
2	reserved	X	R	reserved - don't use, always write 0	
3	out_on	0	R/W	Enables the output current sinks (pin LED_OUT1/2)	
				0	outputs disabled
				1	outputs enabled ( <a href="#">out_on</a> and <a href="#">mode_setting</a> are automatically cleared after a flash pulse)

1. The MSB bit of this register not used to protect the LED; therefore the maximum assist light current = half the maximum flash current

Table 13. *Strobe Signalling Register*

Addr: 7		Strobe Signalling Register			
This register defines the flash current reducing and mode for STROBE					
Bit	Bit Name	Default	Access	Description	
6	strobe_type	1	R/W	Defines if the STROBE input is edge or level sensitive; see also bit <a href="#">strobe_on</a> (page 25)	
				0	STROBE input is edge sensitive
				1	STROBE input is level sensitive
7	strobe_on	1	R/W	Enables the STROBE input	
				0	STROBE input disabled
				1	STROBE input enabled in flash mode

Table 14. *Fault Register*

Addr: 8		Fault Register			
This register identifies all the different fault conditions and provide information about the LED detection					
Bit	Bit Name	Default	Access	Description	
0	fault_uvlo	0	R/sC <sup>1</sup>	an undervoltage event has happened - see <a href="#">Current Reduction by VIN measurements in Flash Mode on page 15</a>	
				0	No
				1	Yes
1	reserved	0	R	reserved - don't use	
2	reserved	0	R	reserved - don't use	
3	fault_txmask	0	R/sC <sup>1</sup>	TXMASK/TORCH event triggered during flash - see <a href="#">TXMASK event occurred on page 12</a>	
				0	No
				1	Yes
4	fault_timeout	0	R/sC <sup>1</sup>	see <a href="#">Flash Timeout on page 12</a>	
				0	No fault
				1	Flash timeout exceeded
5	fault_overtemp	0	R/sC <sup>1</sup>	see <a href="#">Overtemperature Protection on page 12</a>	
				0	No fault
				1	Junction temperature limit has been exceeded
6	fault_led_short	0	R/sC <sup>1</sup>	see <a href="#">Short Circuit Protection on page 12</a>	
				0	No fault
				1	A shorted LED is detected (pin LED_OUT1/2)
7	fault_ovp	0	R/sC <sup>1</sup>	see <a href="#">Overvoltage Protection on page 11</a>	
				0	No fault
				1	An overvoltage condition is detected (pin VOUT)

1. R/sC = Read, self clear; after readout the register is automatically cleared

Table 15. *PWM and Indicator Register*

Addr: 9		PWM and Indicator Register			
		This register defines the PWM mode (e.g. for indicator) and 4/1MHz mode switching			
Bit	Bit Name	Default	Access	Description	
1:0	inct_pwm	00	R/W	Define the AS3643 PWM with 31.25kHz operation for indicator or low current mode ( <code>mode_setting=01</code> )	
				00	1/16 duty cycle
				01	2/16 duty cycle
				10	3/16 duty cycle
				4/16 duty cycle	
2	freq_switch_on	0	R/W	Exact frequency switching between 4MHz/1MHz for assist and flash modes for operation close to maximum pulsewidth	
				0	Pulseskip operation is allowed for all modes - results in better efficiency
				1	In flash and assist light mode (indicator mode or low current mode using PWM always will use pulseskip) if <code>led_current</code> $\geq 40h$ , the DCDC is running at 4MHz or 1MHz (pulseskip is disabled) - results in improved noise performance;

Table 17. *Minimum LED Current Register*

Addr: Eh		Minimum LED Current Register		
		This register reports the minimum LED current from the last operation cycle		
Bit	Bit Name	Default	Access	Description
7:0	led_current_min <sup>12</sup>	00h	R	Minimum current through the current sink (only including all current reductions as described in <a href="#">Current Reduction by VIN measurements in Flash Mode</a> excluding current reductions caused by TXMASK)

- As the internal change of this register is asynchronous to the readout, it is recommended to readout the register after the flash pulse. The register will store the minimum current through the LED after e.g. a previous flash. This current can be used for a subsequent flash pulse for a safe operating range.
- This register is only set if an actual current reduction happens (`fault_uvlo` (see page 25)=1) otherwise `led_current_min=0`.

Table 18. *Actual LED Current Register*

Addr: Fh		Actual LED Current Register		
		This register reports the actual set LED current		
Bit	Bit Name	Default	Access	Description
7:0	led_current_actual <sup>1</sup>	00h	R	Actual set current through the current sink (including all current reductions as described in <a href="#">Flash Current Reductions</a> including LED current ramp up/down)

- As the internal change of this register is asynchronous to the readout, it is recommended to readout the register twice and compare the results.

## Register Map

Table 21. Register Map <sup>1</sup>

Register Definition	Addr	Default	Content								
			b7	b6	b5	b4	b3	b2	b1	b0	
ChipID	0	Bxh	fixed_id				version				
Current Set1	1	9Ch	led_current always write same content in register Current Set1 and Current Set2								
Current Set2	2	9Ch	always write same content in register Current Set1 and Current Set2								
TXMask	3	68h	flash_txmask_current			coil_peak		ext_torch_on			
Low Voltage	4	2Ch	const_v_mode	vin_low_v_shut_down	vin_low_v			vin_low_v_run			
Flash Timer	5	23h	flash_timeout								
Control	6	00h					out_on	reserve_d	mode_setting		
Strobe Signalling	7	C0h	strobe_on	strobe_type							
Fault	8	00h	fault_ovp	fault_led_short	fault_ovtemp	fault_timeout	fault_txmask	reserve_d	reserve_d	fault_uvlo	
PWM and Indicator	9	00h						freq_switch_on	inct_pwm		
Minimum LED Current	Eh	00h	led_current_min								
Actual LED Current	Fh	00h	led_current_actual								

1. Always write '0' to undefined register bits (e.g. to bits 4..7 of register 6)

## 9 Application Information

### External Components

#### Input Capacitor $C_{VIN}$

Low ESR input capacitors reduce input switching noise and reduce the peak current drawn from the battery. Ceramic capacitors are required for input decoupling and should be located as close to the device as is practical.

Table 22. Recommended Input Capacitor

Part Number	C	TC Code	Rated Voltage	Size	Manufacturer
GRM188R60J106ME47	10 $\mu$ >3 $\mu$ F@4.5V >2 $\mu$ F@5.25V	X5R	6V3	0603	Murata <a href="http://www.murata.com">www.murata.com</a>
LMK107BBJ106MA	10 $\mu$ >3 $\mu$ F@4.5V	X5R	6V3	0603	Taiyo Yuden <a href="http://www.t-yuden.com">www.t-yuden.com</a>

If a different input capacitor is chosen, ensure similar ESR value and at least 3 $\mu$ F capacitance at the maximum input supply voltage. Larger capacitor values (C) may be used without limitations.

Add a smaller capacitor in parallel to the input pin VIN (e.g. Murata GRM155R61C104, >50nF @ 3V, 0402 size).

#### Output Capacitor $C_{VOUT}$

Low ESR capacitors should be used to minimize VOUT ripple. Multi-layer ceramic capacitors are recommended since they have extremely low ESR and are available in small footprints. The capacitor should be located as close to the device as is practical.

X5R dielectric material is recommended due to their ability to maintain capacitance over wide voltage and temperature range.

Table 23. Recommended Output Capacitor

Part Number	C	TC Code	Rated Voltage	Size	Manufacturer
GRM219R61A116U	10 $\mu$ F +/-10% >4.2 $\mu$ F@5V	X5R	10V	0805	Murata <a href="http://www.murata.com">www.murata.com</a>
GRM188R60J106ME84 <sup>1</sup>	10 $\mu$ F +/-20% >4.2 $\mu$ F@4V	X5R	6.3V	0603 (1.6x0.8x0.85mm max. 0.95mm height)	

1. Use only for VLED < 3.75V

If a different output capacitor is chosen, ensure similar ESR values and at least 4.2 $\mu$ F capacitance at 5V output voltage.

### Inductor L<sub>DCDC</sub>

The fast switching frequency (4MHz) of the AS3643 allows for the use of small SMDs for the external inductor. The saturation current I<sub>SATURATION</sub> should be chosen to be above the maximum value of I<sub>LIMIT</sub><sup>11</sup>. The inductor should have very low DC resistance (DCR) to reduce the I<sup>2</sup>R power losses - high DCR values will reduce efficiency.

Table 24. Recommended Inductor

Part Number	L	DCR	I <sub>SATURATION</sub>	Size	Manufacturer
C3-P1.5R	1.5µH	58mΩ	2.4A@25°C, 2.0A <sup>1</sup>	3x3x1.5mm (height is max.)	Mitsumi <a href="http://www.mitsumi.com">www.mitsumi.com</a>
LQM32PN1R0MG0	1.0µH >0.6µH @ 3.0A	60mΩ	3.0A	3.2x2.5x0.9 mm max 1.0mm height	Murata <a href="http://www.murata.com">www.murata.com</a>
LQM2HPN1R0MGC	1.0µH >0.6µH @ 2.0A	100mΩ	1.5A (2.0A) <sup>2</sup>	2.5x2.0x0.9 mm max 1.00mm height	
CIG32W1R0MNE	1.0µH >0.7µH @ 2.7A >0.6µH @ 3.0A	60mΩ +/-25%	3.0A	3.2x2.5mm max 1.0mm height	Samsung Electro- Mechanics <a href="http://www.sem.samsung.co.kr">www.sem.samsung.co.kr</a>
NRH2412T1R0N	1.0µH >0.6µH @ 2.5A	77mΩ	2.5A	2.4x2.4x1.2 mm (height is max.)	Taiyo Yuden <a href="http://www.t-yuden.com">www.t-yuden.com</a>
CKP3225N1R0M	1.0µH >0.6µH @ 3.0A	<60mΩ	3.0A	3.2x2.5x0.9 mm max 1.0mm height	
MAMK2520T1R0M	1.0µH >0.6µH @ 2.75A	45mΩ	3.0A	2.5x2.0x1.2 mm height is max	
MDMK2020T1R0M	1.0µH >0.6µH @ 2.75A	56mΩ	2.55A	2.0x2.0x1.2 mm height is max	
MAKK2016T1R0M	1.0µH >0.6µH @ 2.75A	65mΩ	2.0A <sup>3</sup>	2.0x1.6x1.0 mm height is max	

1. Do not exceed maximum I<sub>SATURATION</sub> - can be ensured by setting `coil_peak` (will limit LED current)
2. Flash cycle limit: 150ms on, 500ms off; repeat maximum 50 times.(if used with default `coil_peak=0b` (2A))
3. Set current limit to 2A (`coil_peak=10b`) - can limit maximum output current.

If a different inductor is chosen, ensure similar DCR values and at least 0.6µH inductance at I<sub>LIMIT</sub>.

### PCB Layout Guideline

The high speed operation requires proper layout for optimum performance. Route the power traces first and try to minimize the area and wire length of the two high frequency/high current loops:

Loop1: CVIN/CVIN2 - LDCDC - pin SW1/2 - pin GND - CVIN/CVIN2

Loop2: CVIN/CVIN2 - LDCDC - pin SW1/2 - pin VOUT1/2 - CVOUT - pin GND - CVIN/CVIN2

11. Can be adjusted in I<sup>2</sup>C mode with register `coil_peak` (see page 22)

At the pin GND a single via (or more vias, which are closely combined) connects to the common ground plane. This via(s) will isolate the DCDC high frequency currents from the common ground (as most high frequency current will flow between Loop1 and Loop2 and will not pass the ground plane) - see the 'island' in Figure 31.

Figure 31. Layout recommendation

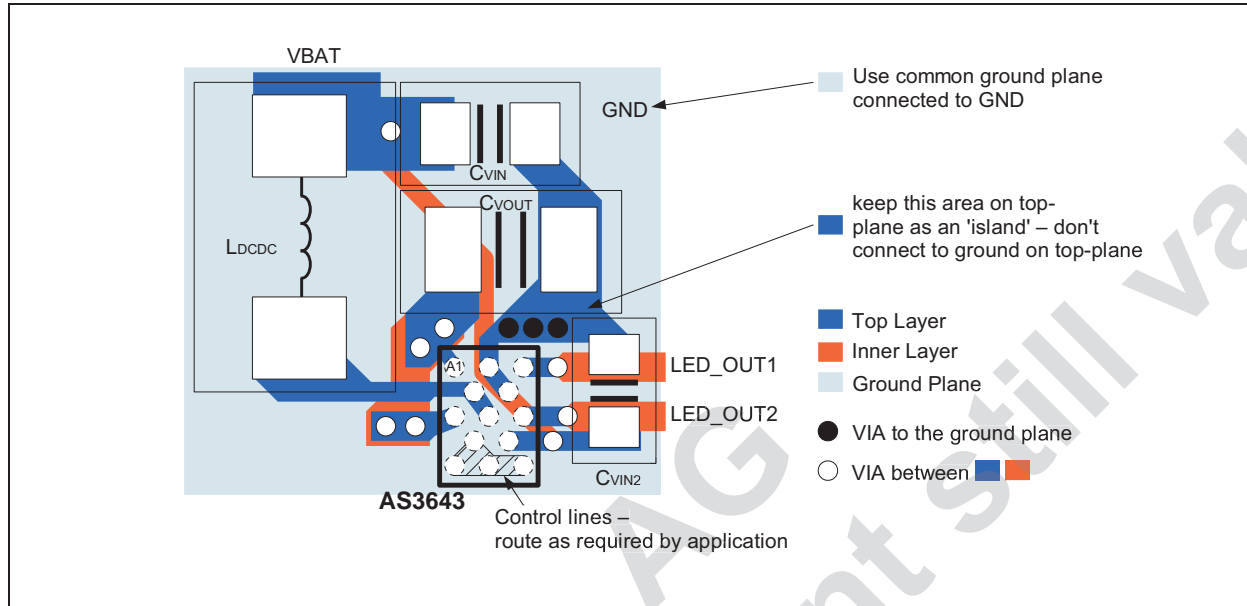

**Note:** If component placement rules allow, move all components close to the AS3643 to reduce the area and length of Loop1 and Loop2.

An additional 100nF (e.g. Murata GRM155R61C104, >50nF @ 3V, 0402 size) capacitor CVIN2 in parallel to CVIN is recommended to filter high frequency noise for the power supply of AS3643. This capacitor should be as close as possible to the GND/VIN pins of AS3643.

## 5V Operating Mode

The AS3643 can be used to power a 5V system (e.g. audio amplifier). The operating mode is selected by setting register bit `const_v_mode` (page 23)=1. In this operating mode, the current sinks are disabled and cannot be switched on (no flash/torch operation is possible).

**Note:** There is always a diode between VIN and VOUT1/2 due to the internal circuit. Therefore VOUT1/2 cannot be completely switched off

Figure 32. 5V Operating Mode

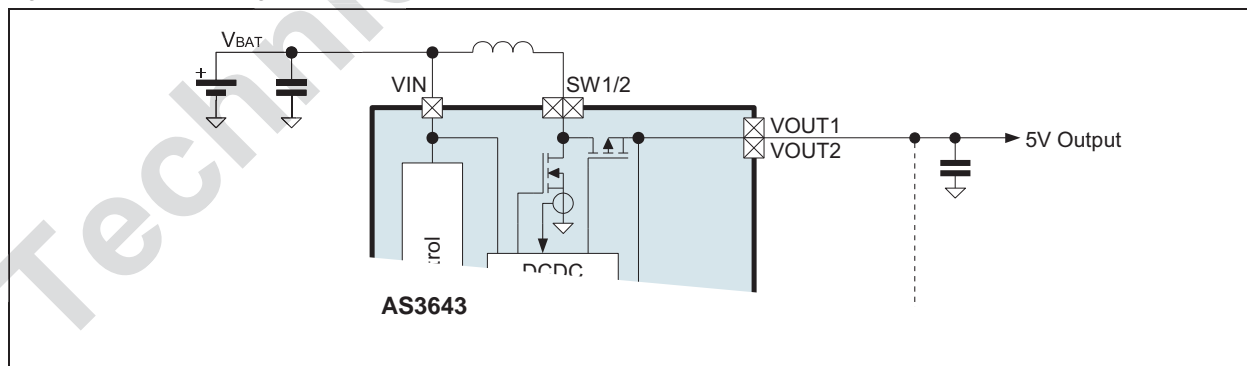

# 10 Package Drawings and Markings

Figure 33. WL-CSP13 Marking

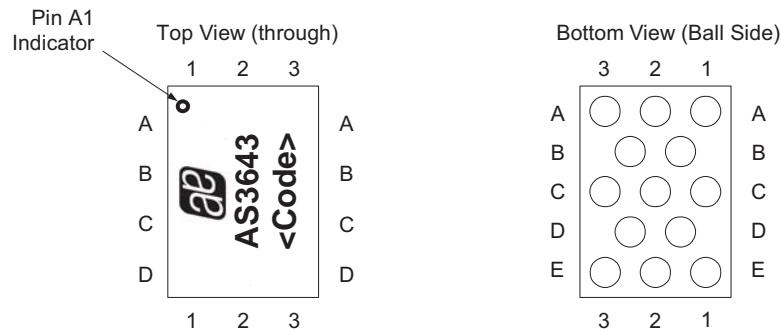

**Note:**

- Line 1: austriamicrosystems logo
- Line 2: AS3643
- Line 3: <Code>  
Encoded Datecode (4 characters)

Figure 34. WL-CSP13 Package Dimensions

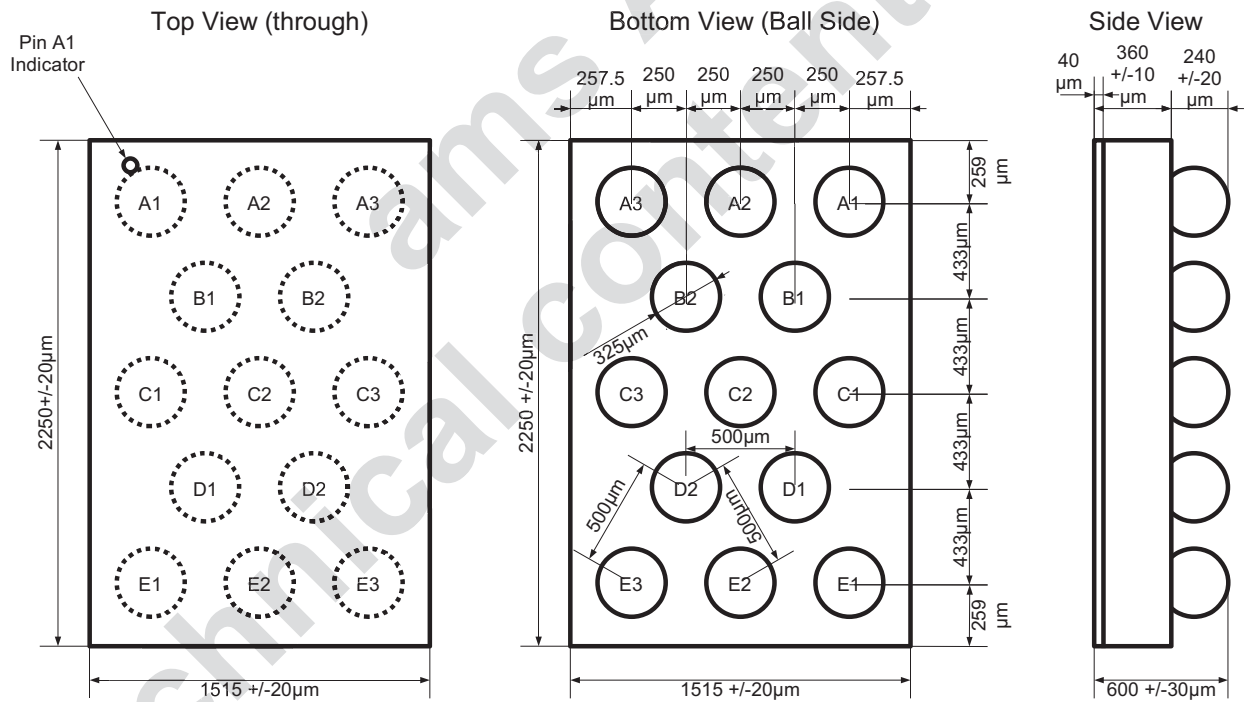

The coplanarity of the balls is 40µm.



## 11 Ordering Information

The devices are available as the standard products shown in [Table 25](#).

Table 25. Ordering Information

Model	Description	Delivery Form	Package
AS3643-ZWLT	1300mA High Current LED Flash Driver	Tape & Reel	13-pin WL-CSP (2.25x1.5x0.6mm) 0.5mm pitch RoHS compliant / Pb-Free / Green

**Note:** All products are RoHS compliant and austriamicrosystems green.

Buy our products or get free samples online at ICdirect: <http://www.austriamicrosystems.com/ICdirect>

Technical support is found at <http://www.austriamicrosystems.com/Technical-Support>

For further information and requests, please contact us <mailto:sales@austriamicrosystems.com>  
or find your local distributor at <http://www.austriamicrosystems.com/distributor>

**Note:** AS3643-ZWLT

AS3643-

Z Temperature Range: -30°C - 85°C

WL Package: Wafer Level Chip Scale Package (WL-CSP) 2.25x1.5x0.6mm

T Delivery Form: Tape & Reel

## Copyrights

Copyright © 1997-2012, austriamicrosystems AG, Schloss Premstaetten, 8141 Unterpremstaetten, Austria-Europe. Trademarks Registered ®. All rights reserved. The material herein may not be reproduced, adapted, merged, translated, stored, or used without the prior written consent of the copyright owner.

All products and companies mentioned are trademarks or registered trademarks of their respective companies.

## Disclaimer

Devices sold by austriamicrosystems AG are covered by the warranty and patent indemnification provisions appearing in its Term of Sale. austriamicrosystems AG makes no warranty, express, statutory, implied, or by description regarding the information set forth herein or regarding the freedom of the described devices from patent infringement. austriamicrosystems AG reserves the right to change specifications and prices at any time and without notice. Therefore, prior to designing this product into a system, it is necessary to check with austriamicrosystems AG for current information. This product is intended for use in normal commercial applications. Applications requiring extended temperature range, unusual environmental requirements, or high reliability applications, such as military, medical life-support or life-sustaining equipment are specifically not recommended without additional processing by austriamicrosystems AG for each application. For shipments of less than 100 parts the manufacturing flow might show deviations from the standard production flow, such as test flow or test location.

The information furnished here by austriamicrosystems AG is believed to be correct and accurate. However, austriamicrosystems AG shall not be liable to recipient or any third party for any damages, including but not limited to personal injury, property damage, loss of profits, loss of use, interruption of business or indirect, special, incidental or consequential damages, of any kind, in connection with or arising out of the furnishing, performance or use of the technical data herein. No obligation or liability to recipient or any third party shall arise or flow out of austriamicrosystems AG rendering of technical or other services.



## Contact Information

### Headquarters

austriamicrosystems AG

Tobelbaderstrasse 30

Schloss Premstaetten

A-8141 Austria

Tel: +43 (0) 3136 500 0

Fax: +43 (0) 3136 525 01

For Sales Offices, Distributors and Representatives, please visit:

<http://www.austriamicrosystems.com/contact>

## Looking for pricing, stock, or lifecycle information?

Click below to explore more details on WIN SOURCE:

 [View AS3643-ZWLT-500 on WIN SOURCE](#)

 [ams Information](#)

## Optimize Your Supply Chain with WIN SOURCE Solutions

-  Global Sourcing Solution
-  Obsolete Management
-  Cost Control Management
-  Shortage Management
-  Alternative Solution
-  Excess Inventory Management