



**THE DATASHEET OF
AS339MTR-G1**



Description

The AS339/339A consist of four independent precision voltage comparators with a typical offset voltage of 2.0mV and high gain. They are specifically designed to operate from a single power supply over wide range of voltages. Operation from split power supply is also possible and the low power supply current drain is independent of the magnitude of the power supply voltage.

The AS339/339A series are compatible with industry standard 339. The AS339A has more stringent input offset voltage than the AS339.

The AS339 is available in SO-14 and TSSOP-14 packages, and the AS339A is available in SO-14 package.

Features

- Wide Supply Voltage Range
 - Single Supply: 2.0V to 36V
 - Dual Supplies: $\pm 1.0V$ to $\pm 18V$
- Low Supply Current Drain: 0.9mA
- Low Input Bias Current: 25nA (Typical)
- Low Input Offset Current: $\pm 5.0nA$ (Typical)
- Low Input Offset Voltage: 2.0mV (Typical)
- Input Common Mode Voltage Range Includes Ground
- Differential Input Voltage Range Equals to the Power Supply Voltage
- Low Output Saturation Voltage: 200mV at 4mA
- Open Collector Output
- Lead-Free Packages: SO-14, TSSOP-14
 - **Totally Lead-Free; RoHS Compliant (Notes 1 & 2)**
- Lead-Free Packages, Available in "Green" Molding Compound: SO-14, TSSOP-14
 - **Totally Lead-Free & Fully RoHS Compliant (Notes 1 & 2)**
 - **Halogen and Antimony Free. "Green" Device (Note 3)**

- Notes:
1. No purposely added lead. Fully EU Directive 2002/95/EC (RoHS), 2011/65/EU (RoHS 2) & 2015/863/EU (RoHS 3) compliant.
 2. See <https://www.diodes.com/quality/lead-free/> for more information about Diodes Incorporated's definitions of Halogen- and Antimony-free, "Green" and Lead-free.
 3. Halogen- and Antimony-free "Green" products are defined as those which contain <900ppm bromine, <900ppm chlorine (<1500ppm total Br + Cl) and <1000ppm antimony compounds.

Pin Assignments

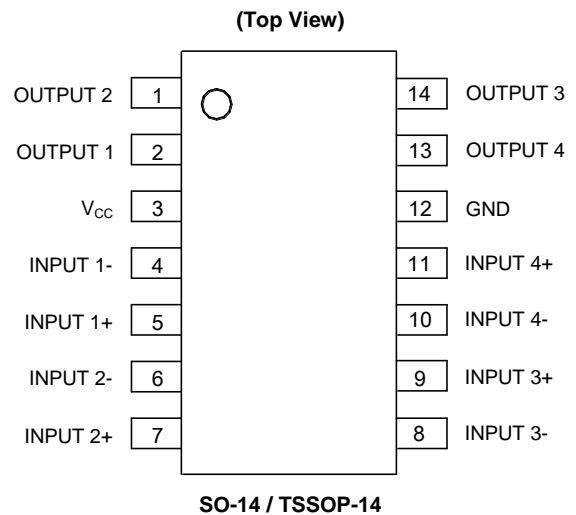

Applications

- Battery Charger
- Cordless Telephone
- Switching Power Supply
- DC-DC Module
- PC Motherboard
- Communication Equipment

Typical Applications Circuit

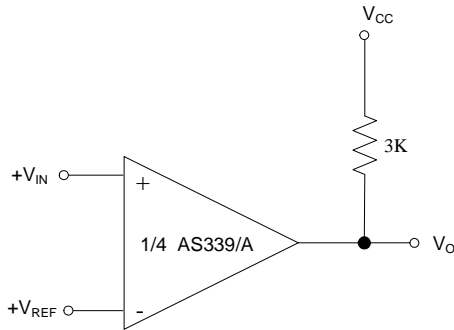

Basic Comparator

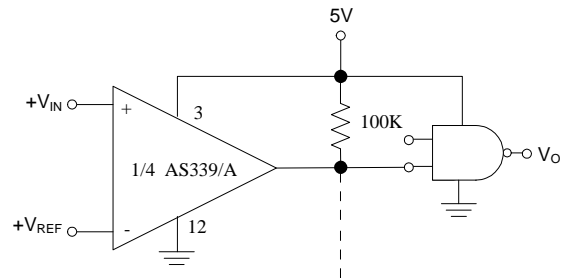

Driving CMOS

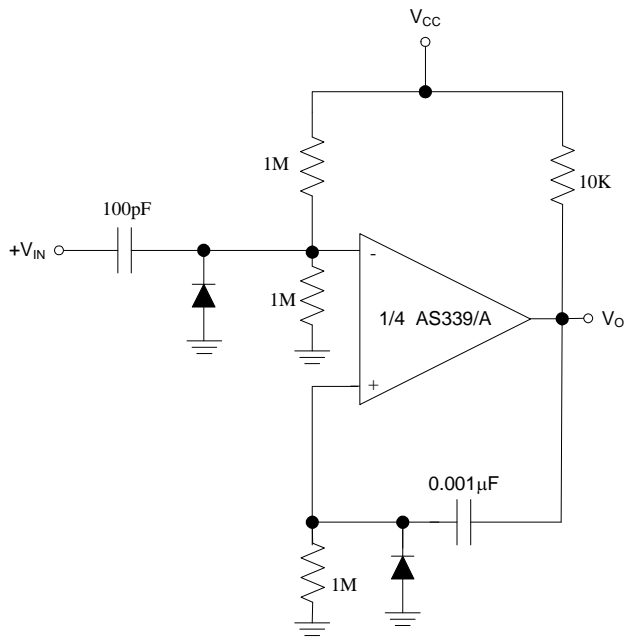

One Shot Multivibrator

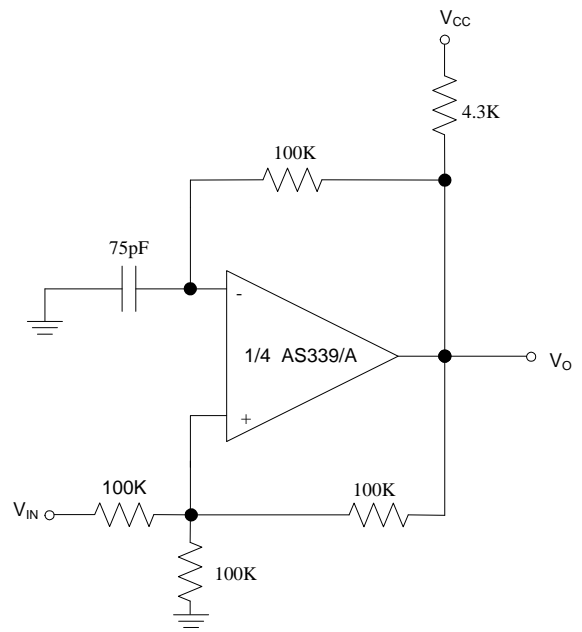

Squarewave Oscillator

Functional Block Diagram

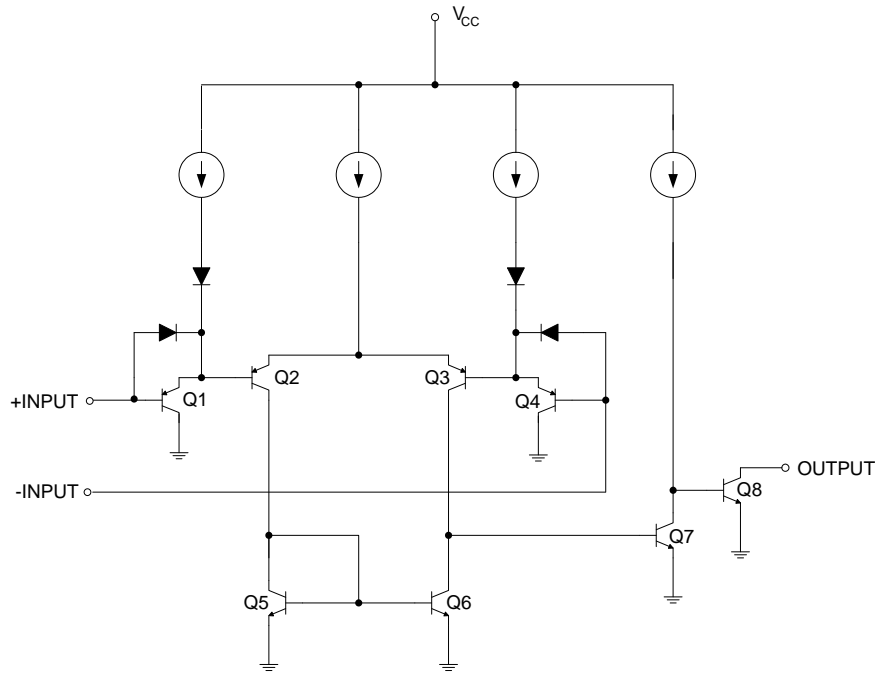

Absolute Maximum Ratings (Note 4)

Symbol	Parameter	Rating	Unit
V _{CC}	Supply Voltage	40	V
V _{ID}	Differential Input Voltage	40	V
V _{IN}	Input Voltage	-0.3 to 40	V
I _{IN}	Input Current (V _{IN} < -0.3V) (Note 5)	50	mA
—	Output Short-Circuit to Ground	Continuous	—
P _D	Power Dissipation (T _A = +25°C)	SO-14	890
		TSSOP-14	790
T _J	Operating Junction Temperature	+150	°C
T _{STG}	Storage Temperature Range	-65 to +150	°C
T _{LEAD}	Lead Temperature (Soldering, 10 Seconds)	+260	°C

- Notes:
- Stresses greater than those listed under “Absolute Maximum Ratings” may cause permanent damage to the device. These are stress ratings only, and functional operation of the device at these or any other conditions beyond those indicated under “Recommended Operating Conditions” is not implied. Exposure to “Absolute Maximum Ratings” for extended periods may affect device reliability.
 - This input current will only exist when the voltage at any of the input leads is driven negative. It is due to the collector-base junction of the input PNP transistors becoming forward biased and thereby acting as input diode clamps. In addition to this diode action, there is also lateral NPN parasitic transistor action on the IC chip. This transistor action can cause the output voltages of the comparators to go to the V+ voltage level (or to ground for a large overdrive) for the time duration that an input is driven negative. This is not destructive and normal output states will re-establish when the input voltage, which was negative, again returns to a value greater than -0.3 V_{DC} (at +25°C).

Recommended Operating Conditions

Symbol	Parameter	Min	Max	Unit
V _{CC}	Supply Voltage	2	36	V
T _A	Operating Temperature Range	-40	+85	°C

Electrical Characteristics

(Limits in standard typeface are for T_A = +25°C, **bold** typeface applies over T_A = -40°C to +85°C (Note 6), V_{CC} = 5V, GND = 0V, unless otherwise specified.)

Parameter	Conditions		Min	Typ	Max	Unit
Input Offset Voltage	V _O = 1.4V, R _S = 0Ω, V _{CC} from 5V to 30V	AS339	—	2	5	mV
			—	—	7	
		AS339A	—	2	3	
			—	—	5	
Input Bias Current	I _{IN+} or I _{IN-} with output in Linear Range, V _{CM} = 0V	—	25	250	nA	
		—	—	400		
Input Offset Current	I _{IN+} - I _{IN-} , V _{CM} = 0V	—	5.0	50	nA	
		—	—	200		
Input Common Mode Voltage Range (Note 7)	V _{CC} = 30V		0	—	V _{CC} -1.5	V
Supply Current	R _L = ∞	V _{CC} = 5V	—	0.9	2.0	mA
			—	—	3.0	
		V _{CC} = 30V	—	1.2	2.5	
			—	—	3.5	
Voltage Gain	R _L ≥ 15kΩ, V _{CC} = 15V, V _O = 1V to 11V		50	200	—	V/mV
Large Signal Response Time	V _{IN} = TTL Logic Swing, V _{REF} = 1.4V V _{RL} = 5V, R _L = 5.1kΩ		—	200	—	ns
Response Time	V _{RL} = 5V, R _L = 5.1kΩ		—	1.3	—	μs
Output Sink Current	V _{IN-} = 1V, V _{IN+} = 0, V _O = 1.5V		6.0	16	—	mA
Output Leakage Current	V _{IN-} = 0V, V _{IN+} = 1V, V _O = 5V		—	0.1	—	nA
	V _{IN-} = 0V, V _{IN+} = 1V, V _O = 30V		—	—	1	μA
Saturation Voltage	V _{IN-} = 1V, V _{IN+} = 0, I _{SINK} ≤ 4mA		—	200	400	mV
			—	—	500	
Thermal Resistance (Junction to Case)	SO-14		—	15	—	°C/W
	TSSOP-14		—	6	—	
Thermal Resistance (Junction to Ambient)	SO-14		—	89	—	
	TSSOP-14		—	125	—	

Notes: 6. Limits over the full temperature are guaranteed by design, but not tested in production.

7. The input common-mode voltage of either input signal voltage should not be allowed to go negatively by more than 0.3V (at +25°C). The upper end of the common-mode voltage range is V_{CC} -1.5V (at +25°C), but either or both inputs can go to +36V without damages, independent of the magnitude of the V_{CC}.

Performance Characteristics

Supply Voltage vs. Supply Current

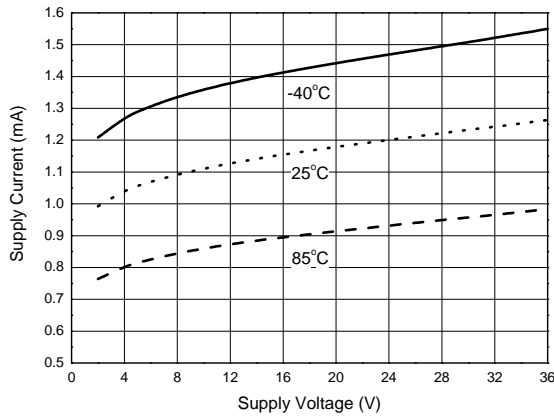

Supply Voltage vs. Input Bias Current

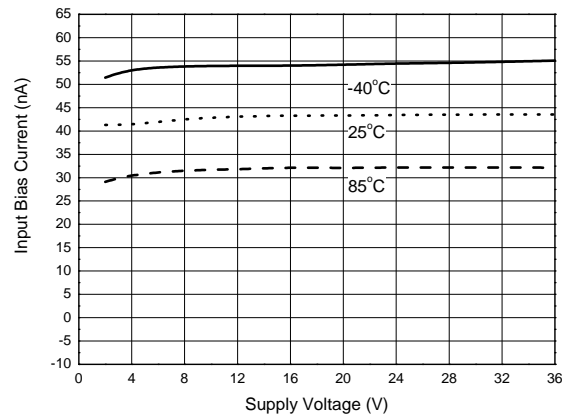

Output Sink Current vs. Saturation Voltage

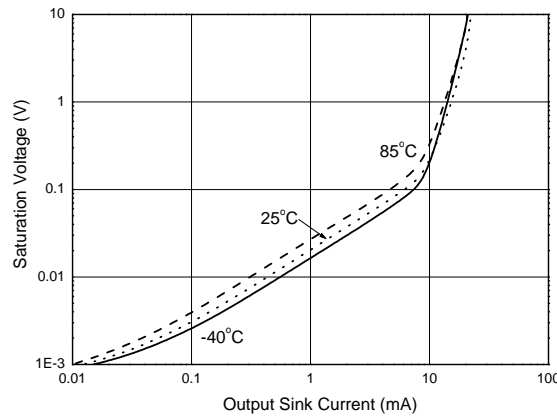

Response Time for 5mV Input Overdrive - Negative Transition

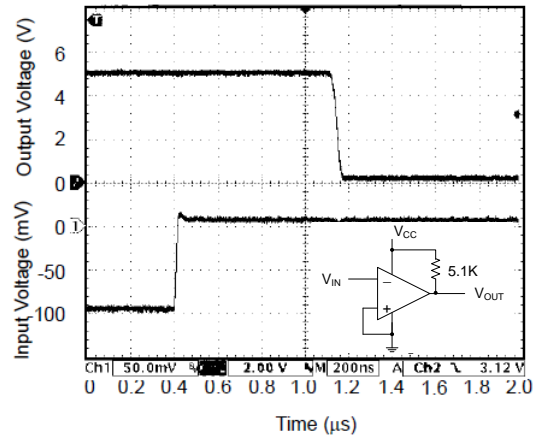



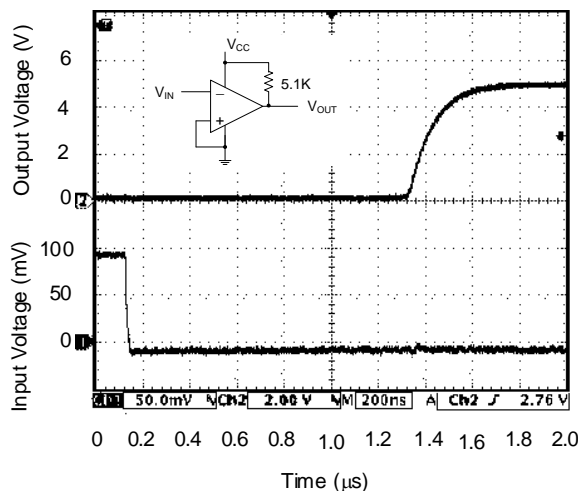



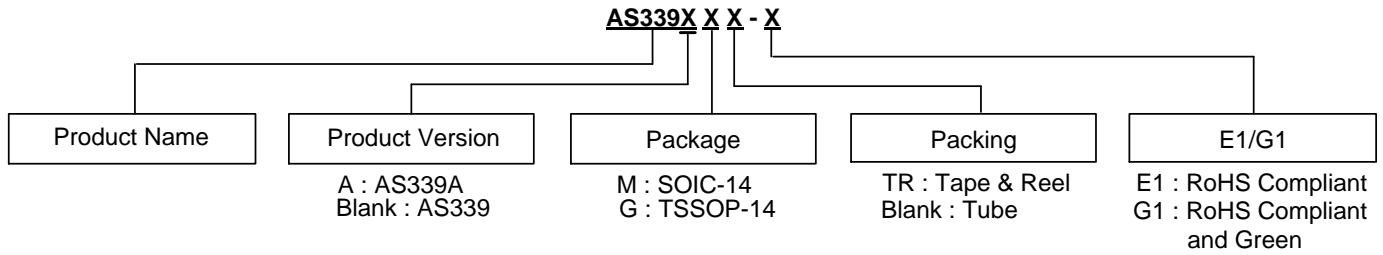



Response Time for 5mV Input Overdrive - Positive Transition



Ordering Information



	Part Number	Package (Note 9)	RoHS Compliant Lead Free / Green	Marking ID	Packing	Quantity	Status (Note 8)	Alternative
 Lead-Free	AS339M-E1	SO-14	Lead Free	AS339M-E1	Tube	NA	End of Life	AS339MTR-G1
 Lead-Free	AS339MTR-E1	SO-14	Lead Free	AS339M-E1	Tape & Reel	2500	NRND	AS339MTR-G1
 Lead-Free	AS339AM-E1	SO-14	Lead Free	AS339AM-E1	Tube	NA	End of Life	AS339AMTR-G1
 Lead-Free	AS339AMTR-E1	SO-14	Lead Free	AS339AM-E1	Tape & Reel	2500	NRND	AS339AMTR-G1
 Lead-Free Green	AS339M-G1	SO-14	Green	AS339M-G1	Tube	NA	End of Life	AS339MTR-G1
 Lead-Free Green	AS339MTR-G1	SO-14	Green	AS339M-G1	Tape & Reel	2500	In Production	—
 Lead-Free Green	AS339AM-G1	SO-14	Green	AS339AM-G1	Tube	NA	End of Life	AS339AMTR-G1
 Lead-Free Green	AS339AMTR-G1	SO-14	Green	AS339AM-G1	Tape & Reel	2500	In Production	—
 Lead-Free	AS339GTR-E1	TSSOP-14	Lead Free	EGS339	Tape & Reel	2500	NRND	AS339GTR-G1
 Lead-Free Green	AS339GTR-G1	TSSOP-14	Green	GG339	Tape & Reel	2500	In Production	—

- Notes:
- 8. All variants in Tube packing with package SO-14 are End of Life.
All variants with package DIP-14 are End of Life without replacements.
NRND: Not Recommended for New Design.
 - 9. For packaging details, go to our website at: <https://www.diodes.com/design/support/packaging/diodes-packaging/>.

Marking information

(1) SO-14

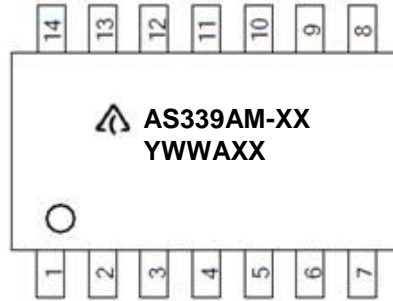
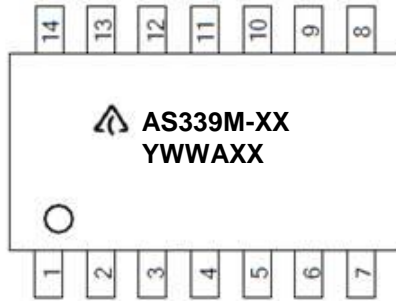

First Line: Logo and Marking ID
(See Ordering Information)
Second Line: Date Code
Y: Year
WW: Work Week of Molding
A: Assembly House Code
XX: 7th and 8th Digits of Batch Number

(2) TSSOP14

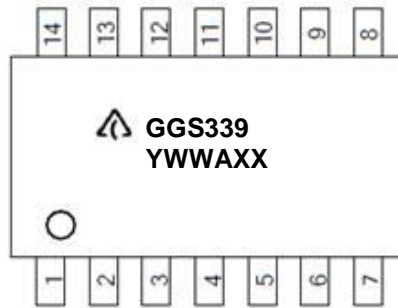
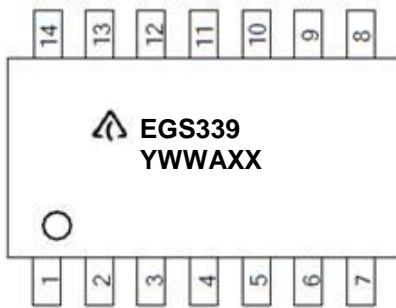

First Line: Logo and Marking ID
(See Ordering Information)
Second Line: Date Code
Y: Year
WW: Work Week of Molding
A: Assembly House Code
XX: 7th and 8th Digits of Batch Number

Package Outline Dimensions (All dimensions in mm(inch).)

(1) Package Type: SO-14

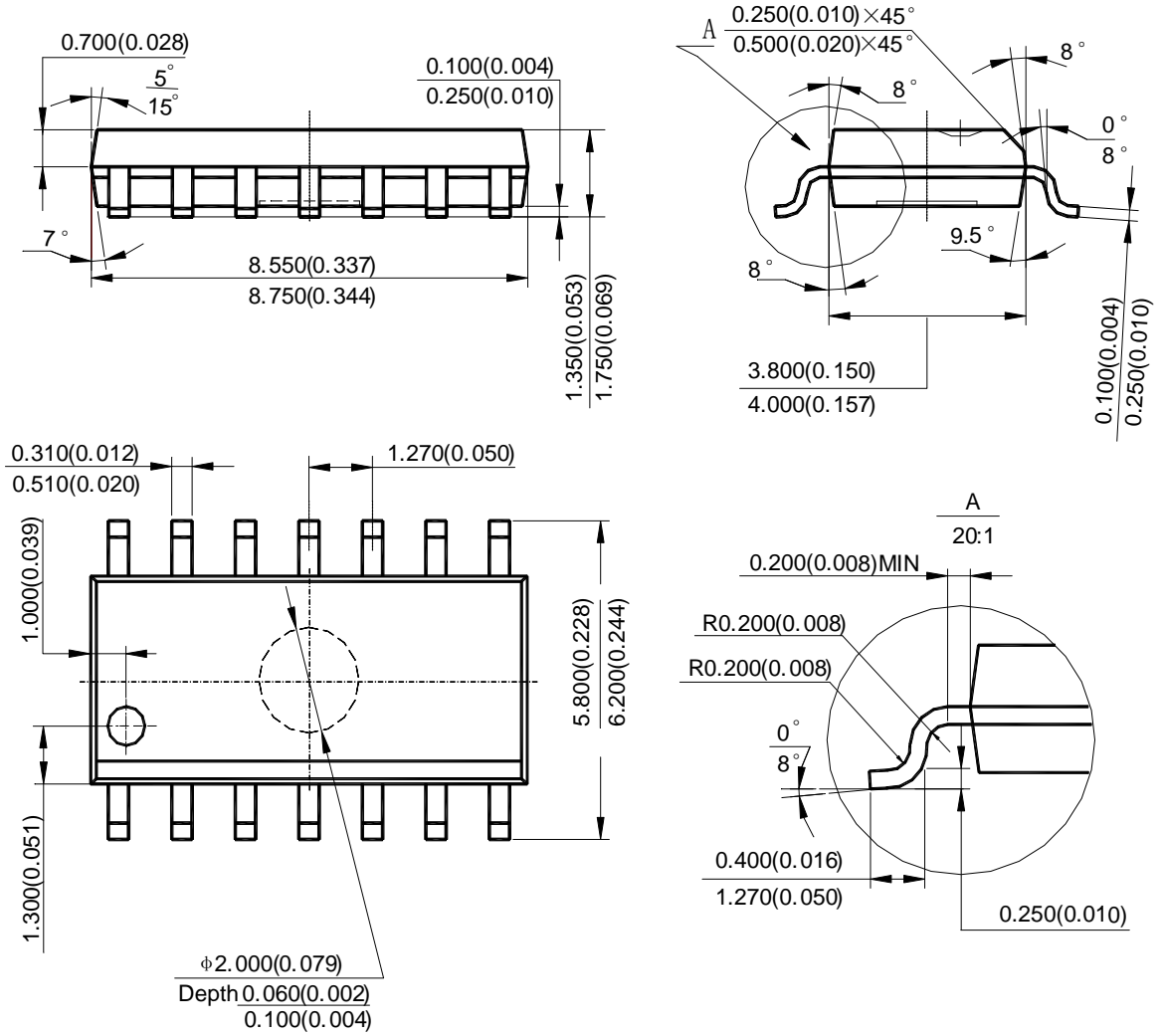

Note: Eject hole, oriented hole and mold mark is optional.

Suggested Pad Layout

(1) Package Type: SO-14

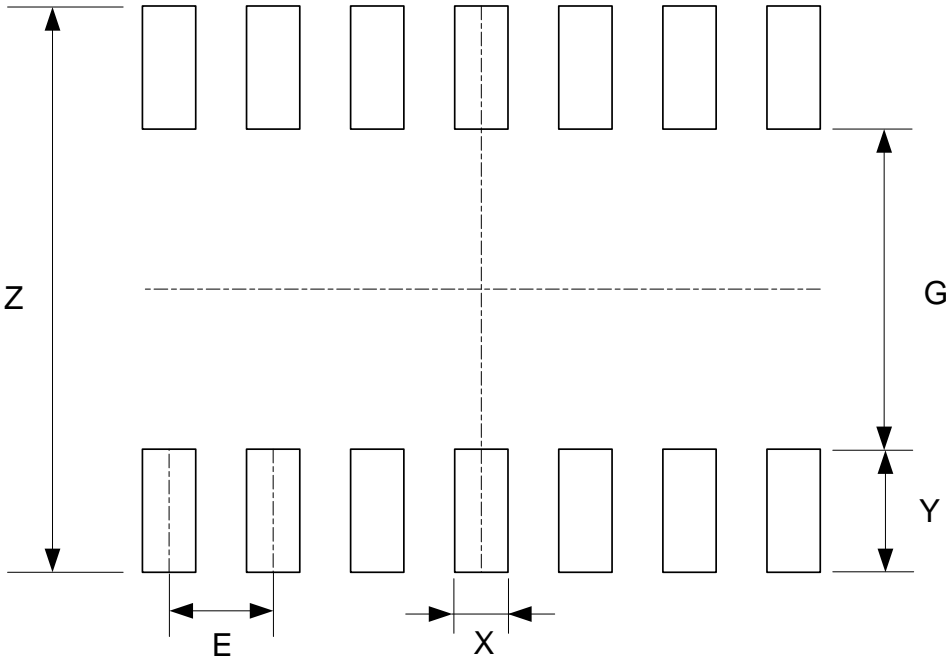

Dimensions	Z (mm)/(inch)	G (mm)/(inch)	X (mm)/(inch)	Y (mm)/(inch)	E (mm)/(inch)
Value	6.900/0.272	3.900/0.154	0.650/0.026	1.500/0.059	1.270/0.050

Suggested Pad Layout (Cont.)

(2) Package Type: TSSOP-14

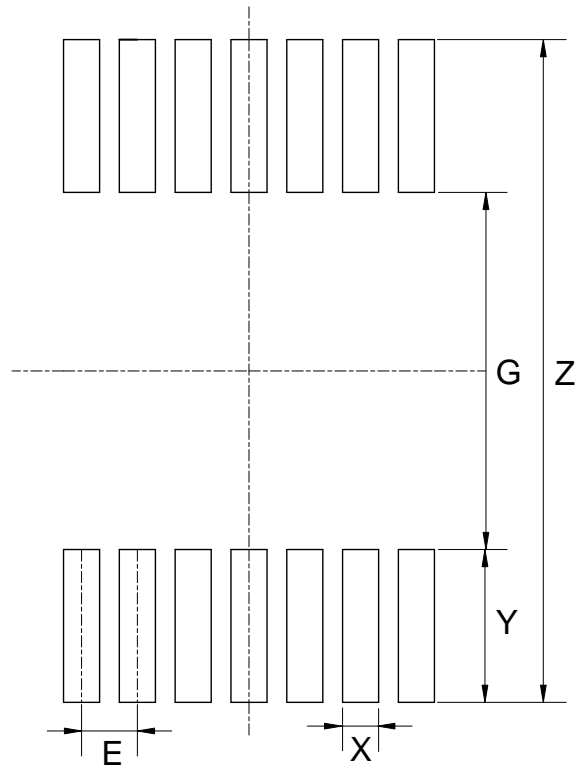

Dimensions	Z (mm)/(inch)	G (mm)/(inch)	X (mm)/(inch)	Y (mm)/(inch)	E (mm)/(inch)
Value	7.720/0.304	4.160/0.164	0.420/0.017	1.780/0.070	0.650/0.026

IMPORTANT NOTICE

DIODES INCORPORATED MAKES NO WARRANTY OF ANY KIND, EXPRESS OR IMPLIED, WITH REGARDS TO THIS DOCUMENT, INCLUDING, BUT NOT LIMITED TO, THE IMPLIED WARRANTIES OF MERCHANTABILITY AND FITNESS FOR A PARTICULAR PURPOSE (AND THEIR EQUIVALENTS UNDER THE LAWS OF ANY JURISDICTION).

Diodes Incorporated and its subsidiaries reserve the right to make modifications, enhancements, improvements, corrections or other changes without further notice to this document and any product described herein. Diodes Incorporated does not assume any liability arising out of the application or use of this document or any product described herein; neither does Diodes Incorporated convey any license under its patent or trademark rights, nor the rights of others. Any Customer or user of this document or products described herein in such applications shall assume all risks of such use and will agree to hold Diodes Incorporated and all the companies whose products are represented on Diodes Incorporated website, harmless against all damages.

Diodes Incorporated does not warrant or accept any liability whatsoever in respect of any products purchased through unauthorized sales channel. Should Customers purchase or use Diodes Incorporated products for any unintended or unauthorized application, Customers shall indemnify and hold Diodes Incorporated and its representatives harmless against all claims, damages, expenses, and attorney fees arising out of, directly or indirectly, any claim of personal injury or death associated with such unintended or unauthorized application.

Products described herein may be covered by one or more United States, international or foreign patents pending. Product names and markings noted herein may also be covered by one or more United States, international or foreign trademarks.

This document is written in English but may be translated into multiple languages for reference. Only the English version of this document is the final and determinative format released by Diodes Incorporated.

LIFE SUPPORT

Diodes Incorporated products are specifically not authorized for use as critical components in life support devices or systems without the express written approval of the Chief Executive Officer of Diodes Incorporated. As used herein:

A. Life support devices or systems are devices or systems which:

1. are intended to implant into the body, or
2. support or sustain life and whose failure to perform when properly used in accordance with instructions for use provided in the labeling can be reasonably expected to result in significant injury to the user.

B. A critical component is any component in a life support device or system whose failure to perform can be reasonably expected to cause the failure of the life support device or to affect its safety or effectiveness.

Customers represent that they have all necessary expertise in the safety and regulatory ramifications of their life support devices or systems, and acknowledge and agree that they are solely responsible for all legal, regulatory and safety-related requirements concerning their products and any use of Diodes Incorporated products in such safety-critical, life support devices or systems, notwithstanding any devices- or systems-related information or support that may be provided by Diodes Incorporated. Further, Customers must fully indemnify Diodes Incorporated and its representatives against any damages arising out of the use of Diodes Incorporated products in such safety-critical, life support devices or systems.

Copyright © 2018, Diodes Incorporated

www.diodes.com

Looking for pricing, stock, or lifecycle information?

Click below to explore more details on WIN SOURCE:

 [View AS339MTR-G1 on WIN SOURCE](#)

 [Diodes Incorporated](#) Information

Optimize Your Supply Chain with WIN SOURCE Solutions

-  Global Sourcing Solution
-  Obsolete Management
-  Cost Control Management
-  Shortage Management
-  Alternative Solution
-  Excess Inventory Management