



THE DATASHEET OF MPC9447ACR2



The Freescale Semiconductor, Inc. MPC9447 is a 3.3 V or 2.5 V compatible, 1:9 clock fanout buffer targeted for high performance clock tree applications. With output frequencies up to 350 MHz and output skews less than 150 ps, the device meets the needs of most demanding clock applications.

Features

- 9 LVC MOS Compatible Clock Outputs
- 2 Selectable, LVC MOS Compatible Inputs
- Maximum Clock Frequency of 350 MHz
- Maximum Clock Skew of 150 ps
- Synchronous Output Stop in Logic Low State Eliminates Output Runt Pulses
- High-Impedance Output Control
- 3.3 V or 2.5 V Power Supply
- Drives up to 18 Series Terminated Clock Lines
- Ambient Temperature Range -40°C to +85°C
- 32-Lead LQFP Packaging, Pb-free
- Supports Clock Distribution in Networking, Telecommunications, and Computer Applications
- Pin and Function Compatible to MPC947
- **For drop in replacement use 83947AYILN**

**LOW VOLTAGE
3.3 V/2.5 V LVC MOS 1:9
CLOCK FANOUT BUFFER**

**AC SUFFIX
32-LEAD LQFP PACKAGE
Pb-FREE PACKAGE
CASE 873A-03**

Functional Description

MPC9447 is specifically designed to distribute LVC MOS compatible clock signals up to a frequency of 350 MHz. Each output provides a precise copy of the input signal with a near zero skew. The outputs buffers support driving of 50 Ω terminated transmission lines on the incident edge. Each is capable of driving either one parallel terminated or two series terminated transmission lines.

Two selectable independent LVC MOS compatible clock inputs are available, providing support of redundant clock source systems. The MPC9447 CLK_STOP control is synchronous to the falling edge of the input clock. It allows the start and stop of the output clock signal only in a logic low state, and thus, eliminates potential output runt pulses. Applying the OE control will force the outputs into high-impedance mode.

All inputs have an internal pull-up or pull-down resistor preventing unused and open inputs from floating. The device supports a 2.5 V or 3.3 V power supply and an ambient temperature range of -40°C to +85°C. The MPC9447 is pin and function compatible but performance-enhanced to the MPC947.

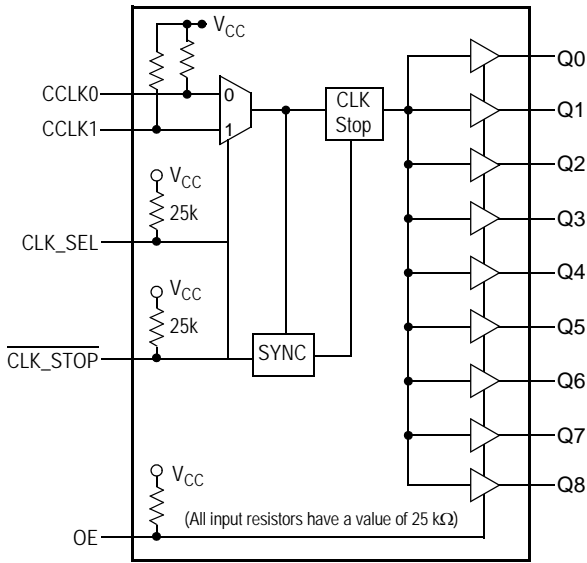

Figure 1. Logic Diagram

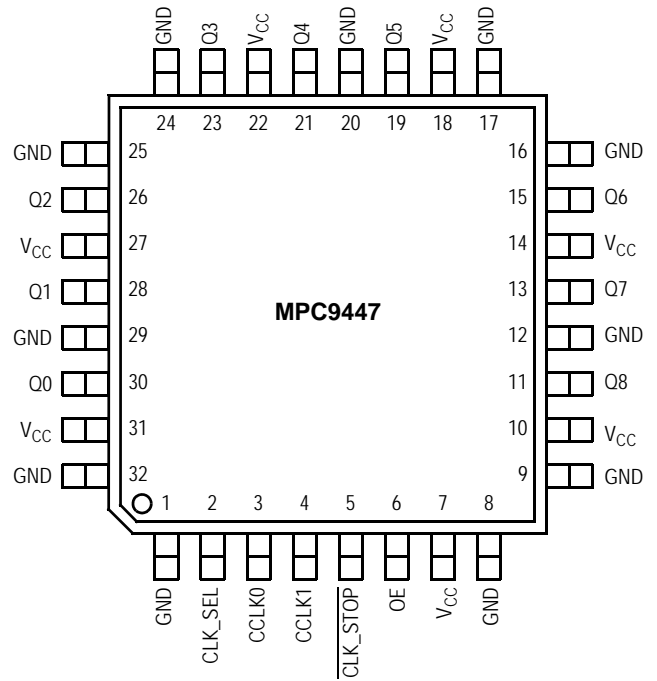

Figure 2. 32-Lead Pinout (Top View)

Table 1. Function Table

Control	Default	0	1
CLK_SEL	1	CLK0 input selected	CLK1 input selected
OE	1	Outputs disabled (high-impedance state) ⁽¹⁾	Outputs enabled
$\overline{\text{CLK_STOP}}$	1	Outputs synchronously stopped in logic low state	Outputs active

1. OE = 0 will high-impedance tristate all outputs independent on $\overline{\text{CLK_STOP}}$.

Table 2. Pin Configurations

Pin	I/O	Type	Function
CCLK0	Input	LVC MOS	Clock Signal Input
CCLK1	Input	LVC MOS	Alternative Clock Signal Input
CLK_SEL	Input	LVC MOS	Clock Input Select
$\overline{\text{CLK_STOP}}$	Input	LVC MOS	Clock Output Enable/Disable
OE	Input	LVC MOS	Output Enable/Disable (high-impedance tristate)
Q0–8	Output	LVC MOS	Clock Outputs
GND	Supply	Ground	Negative Power Supply (GND)
V _{CC}	Supply	V _{CC}	Positive power supply for I/O and core. All V _{CC} pins must be connected to the positive power supply for correct operation

Table 3. General Specifications

Symbol	Characteristics	Min	Typ	Max	Unit	Condition
V_{TT}	Output Termination Voltage		$V_{CC} \div 2$		V	
MM	ESD Protection (Machine model)	200			V	
HBM	ESD Protection (Human body model)	2000			V	
LU	Latch-up Immunity	200			mA	
C_{PD}	Power Dissipation Capacitance		10		pF	Per output
C_{IN}	Input Capacitance		4.0		pF	Inputs

Table 4. Absolute Maximum Ratings⁽¹⁾

Symbol	Characteristics	Min	Max	Unit	Condition
V_{CC}	Supply Voltage	-0.3	3.9	V	
V_{IN}	DC Input Voltage	-0.3	$V_{CC} + 0.3$	V	
V_{OUT}	DC Output Voltage	-0.3	$V_{CC} + 0.3$	V	
I_{IN}	DC Input Current		± 20	mA	
I_{OUT}	DC Output Current		± 50	mA	
T_S	Storage temperature	-65	125	°C	

1. Absolute maximum continuous ratings are those maximum values beyond which damage to the device may occur. Exposure to these conditions or conditions beyond those indicated may adversely affect device reliability. Functional operation at absolute-maximum-rated conditions is not implied.

Table 5. DC Characteristics ($V_{CC} = 3.3 \text{ V} \pm 5\%$, $T_A = -40^\circ\text{C}$ to $+85^\circ\text{C}$)

Symbol	Characteristics	Min	Typ	Max	Unit	Condition
V_{IH}	Input High Voltage	2.0		$V_{CC} + 0.3$	V	LVC MOS
V_{IL}	Input Low Voltage	-0.3		0.8	V	LVC MOS
V_{OH}	Output High Voltage	2.4			V	$I_{OH} = -24 \text{ mA}^{(1)}$
V_{OL}	Output Low Voltage			0.55 0.30	V V	$I_{OL} = 24 \text{ mA}$ $I_{OL} = 12 \text{ mA}$
Z_{OUT}	Output Impedance		17		Ω	
I_{IN}	Input Current ⁽²⁾			± 300	μA	$V_{IN} = V_{CC}$ or GND
I_{CCQ}	Maximum Quiescent Supply Current ⁽³⁾			2.0	mA	All V_{CC} Pins

- The MPC9447 is capable of driving 50Ω transmission lines on the incident edge. Each output drives one 50Ω parallel terminated transmission line to a termination voltage of V_{TT} . Alternatively, the device drives up to two 50Ω series terminated transmission lines (for $V_{CC} = 3.3 \text{ V}$).
- Inputs have pull-down or pull-up resistors affecting the input current.
- I_{CCQ} is the DC current consumption of the device with all outputs open and the input in its default state or open.

Table 6. AC Characteristics ($V_{CC} = 3.3\text{ V} \pm 5\%$, $T_A = -40^\circ\text{C}$ to $+85^\circ\text{C}$)⁽¹⁾

Symbol	Characteristics	Min	Typ	Max	Unit	Condition
f_{ref}	Input Frequency	0		350	MHz	
f_{max}	Output Frequency	0		350	MHz	
$f_{P,REF}$	Reference Input Pulse Width	1.4			ns	
t_r, t_f	CCLK0, CCLK1 Input Rise/Fall Time			1.0 ⁽²⁾	ns	0.8 to 2.0 V
$t_{PLH/HL}$	Propagation Delay CCLK0 or CCLK1 to any Q	1.3		3.3	ns	
$t_{PLZ, HZ}$	Output Disable Time			11	ns	
$t_{PZL, ZH}$	Output Enable Time			11	ns	
t_S	Setup Time CCLK0 or CCLK1 to $\overline{CLK_STOP}$ ⁽³⁾	0.0			ns	
t_H	Hold Time CCLK0 or CCLK1 to $\overline{CLK_STOP}$ ⁽³⁾	1.0			ns	
$t_{sk(O)}$	Output-to-Output Skew			150	ps	
$t_{sk(PP)}$	Device-to-Device Skew			2.0	ns	
$t_{SK(P)}$ DC_Q	Output Pulse Skew ⁽⁴⁾ Output Duty Cycle $f_Q < 170\text{ MHz}$	45	50	300 55	ps %	$DC_{REF} = 50\%$
t_r, t_f	Output Rise/Fall Time	0.1		1.0	ns	0.55 to 2.4 V
t_{JIT}	Buffer Additive Phase Jitter, RMS		0.03		ps	156.25MHz, Integration Range: 12kHz - 20MHz

1. AC characteristics apply for parallel output termination of $50\ \Omega$ to V_{TT} .
2. Violation of the 1.0 ns maximum input rise and fall time limit will affect the device propagation delay, device-to-device skew, reference input pulse width, output duty cycle and maximum frequency specifications.
3. Setup and hold times are referenced to the falling edge of the selected clock signal input.
4. Output pulse skew is the absolute difference of the propagation delay times: $|t_{PLH} - t_{PHL}|$.

Table 7. DC Characteristics ($V_{CC} = 2.5\text{ V} \pm 5\%$, $T_A = -40^\circ\text{C}$ to $+85^\circ\text{C}$)

Symbol	Characteristics	Min	Typ	Max	Unit	Condition
V_{IH}	Input High Voltage	1.7		$V_{CC} + 0.3$	V	LVC MOS
V_{IL}	Input Low Voltage	-0.3		0.7	V	LVC MOS
V_{OH}	Output High Voltage	1.8			V	$I_{OH} = -15\text{ mA}$ ⁽¹⁾
V_{OL}	Output Low Voltage			0.6	V	$I_{OL} = 15\text{ mA}$
Z_{OUT}	Output Impedance		19		Ω	
I_{IN}	Input Current ⁽²⁾			± 300	μA	$V_{IN} = V_{CC}$ or GND
I_{CCQ}	Maximum Quiescent Supply Current ⁽³⁾			2.0	mA	All V_{CC} Pins

1. The MPC9447 is capable of driving $50\ \Omega$ transmission lines on the incident edge. Each output drives one $50\ \Omega$ parallel terminated transmission line to a termination voltage of V_{TT} . Alternatively, the device drives one $50\ \Omega$ series terminated transmission lines per output ($V_{CC} = 2.5\text{ V}$).
2. Inputs have pull-down or pull-up resistors affecting the input current.
3. I_{CCQ} is the DC current consumption of the device with all outputs open and the input in its default state or open.

Table 8. AC Characteristics ($V_{CC} = 2.5\text{ V} \pm 5\%$, $T_A = -40^\circ\text{C}$ to $+85^\circ\text{C}$)(1)

Symbol	Characteristics	Min	Typ	Max	Unit	Condition
f_{ref}	Input Frequency	0		350	MHz	
f_{max}	Output Frequency	0		350	MHz	
$f_{P,REF}$	Reference Input Pulse Width	1.4			ns	
t_r, t_f	CCLK0, CCLK1 Input Rise/Fall Time			1.0 ⁽²⁾	ns	0.7 to 1.7 V
$t_{PLH/HL}$	Propagation Delay CCLK0 or CCLK1 to any Q	1.7		4.4	ns	
$t_{PLZ, HZ}$	Output Disable Time			11	ns	
$t_{PZL, ZH}$	Output Enable Time			11	ns	
t_S	Setup Time CCLK0 or CCLK1 to $\overline{\text{CLK_STOP}}$ ⁽³⁾	0.0			ns	
t_H	Hold Time CCLK0 or CCLK1 to $\overline{\text{CLK_STOP}}$ ⁽³⁾	1.0			ns	
$t_{sk(O)}$	Output-to-Output Skew			150	ps	
$t_{sk(PP)}$	Device-to-Device Skew			2.7	ns	
$t_{SK(P)}$ DC_Q	Output Pulse Skew ⁽⁴⁾ Output Duty Cycle $f_Q < 350\text{ MHz}$	45	50	200 55	ps %	$DC_{REF} = 50\%$
t_r, t_f	Output Rise/Fall Time	0.1		1.0	ns	0.6 to 1.8 V
t_{JIT}	Buffer Additive Phase Jitter, RMS		0.03		ps	156.25MHz, Integration Range: 12kHz - 20MHz

1. AC characteristics apply for parallel output termination of $50\ \Omega$ to V_{TT} .
2. Violation of the 1.0 ns maximum input rise and fall time limit will affect the device propagation delay, device-to-device skew, reference input pulse width, output duty cycle and maximum frequency specifications.
3. Setup and hold times are referenced to the falling edge of the selected clock signal input.
4. Output pulse skew is the absolute difference of the propagation delay times: $|t_{PLH} - t_{PHL}|$.

APPLICATION INFORMATION

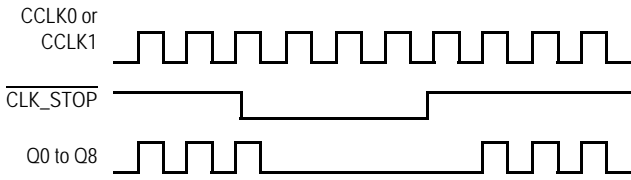

Figure 3. Output Clock Stop (CLK_STOP) Timing Diagram

Driving Transmission Lines

The MPC9447 clock driver was designed to drive high-speed signals in a terminated transmission line environment. To provide the optimum flexibility to the user, the output drivers were designed to exhibit the lowest impedance possible. With an output impedance of $17\ \Omega$ ($V_{CC} = 3.3\text{ V}$), the outputs can drive either parallel or series terminated transmission lines. For more information on transmission lines, the reader is referred to Freescale application note AN1091. In most high performance clock networks, point-to-point distribution of signals is the method of choice. In a point-to-point scheme, either series terminated or parallel terminated transmission lines can be used. The parallel technique terminates the signal at the end of the line with a $50\ \Omega$ resistance to $V_{CC} \div 2$.

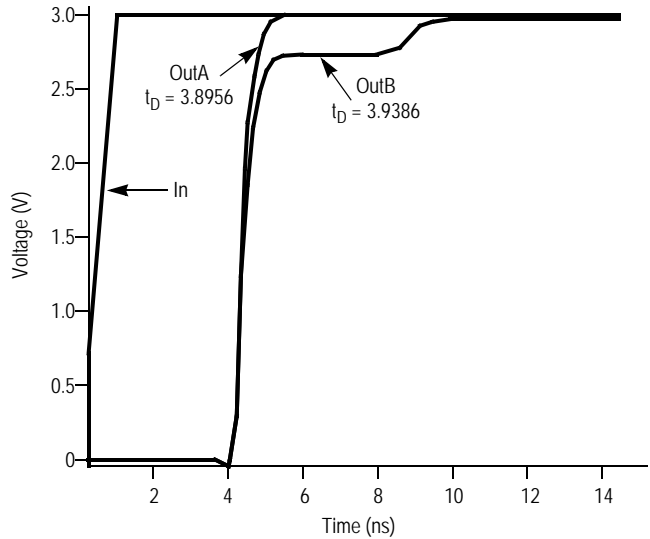

Figure 5. Single versus Dual Line Termination Waveforms

The waveform plots in Figure 5 show the simulation results of an output driving a single line versus two lines. In both cases, the drive capability of the MPC9447 output buffer is more than sufficient to drive $50\ \Omega$ transmission lines on the incident edge. Note from the delay measurements in the simulation, a delta of only 43 ps exists between the two differently loaded outputs. This suggests that the dual line driving need not be used exclusively to maintain the tight output-to-output skew of the MPC9447. The output waveform in Figure 5 shows a step in the waveform; this step is caused by the impedance mismatch seen looking into the driver. The parallel combination of the $33\ \Omega$ series resistor, plus the output impedance, does not match the parallel combination of the line impedances. The voltage wave launched down the two lines will equal:

$$V_L = V_S (Z_0 \div (R_S + R_0 + Z_0))$$

$$Z_0 = 50\ \Omega \parallel 50\ \Omega$$

$$R_S = 33\ \Omega \parallel 33\ \Omega$$

$$R_0 = 17\ \Omega$$

$$V_L = 3.0 (25 \div (16.5 + 17 + 25))$$

$$= 1.28\text{ V}$$

At the load end, the voltage will double, due to the near unity reflection coefficient, to 2.5 V. It will then increment towards the quiescent 3.0 V in steps separated by one round trip delay (in this case 4.0 ns).

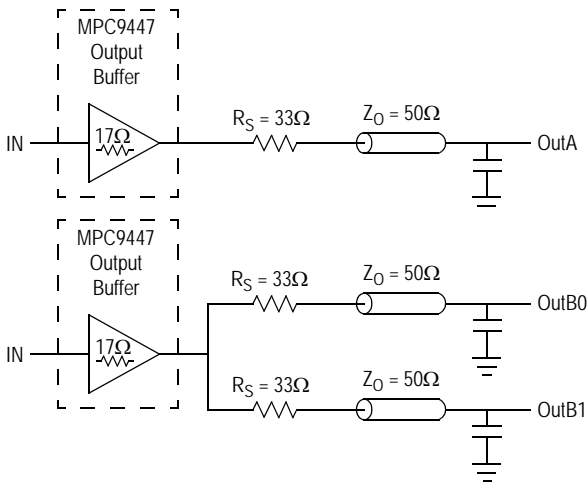

Figure 4. Single versus Dual Transmission Lines

This technique draws a fairly high level of DC current, and thus, only a single terminated line can be driven by each output of the MPC9447 clock driver. For the series terminated case, however, there is no DC current draw; thus, the outputs can drive multiple series terminated lines. Figure 4 illustrates an output driving a single series terminated line versus two series terminated lines in parallel. When taken to its extreme, the fanout of the MPC9447 clock driver is effectively doubled due to its capability to drive multiple lines at $V_{CC} = 3.3\text{ V}$.

Since this step is well above the threshold region, it will not cause any false clock triggering; however, designers may be uncomfortable with unwanted reflections on the line. To better match the impedances when driving multiple lines, the situation in Figure 6 should be used. In this case, the series terminating resistors are reduced such that when the parallel combination is added to the output buffer impedance, the line impedance is perfectly matched.

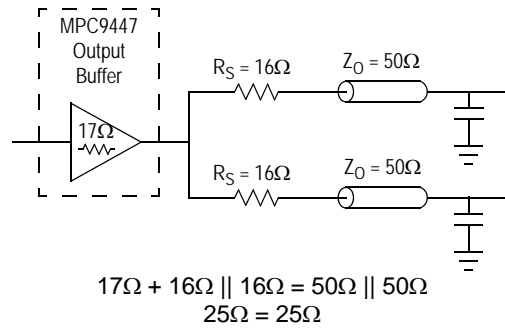

Figure 6. Optimized Dual Line Termination

The Following Figures Illustrate the Measurement Reference for the MPC9447 Clock Driver Circuit

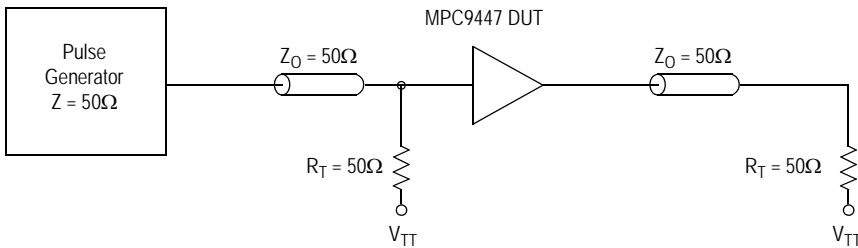

Figure 7. CCLK MPC9447 AC Test Reference for $V_{CC} = 3.3\text{ V}$ and $V_{CC} = 2.5\text{ V}$

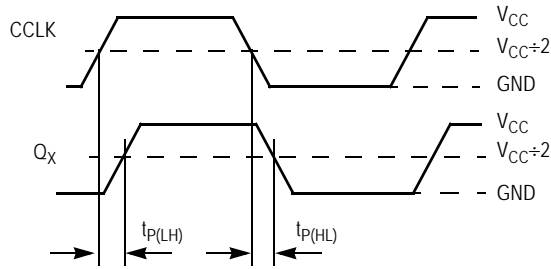
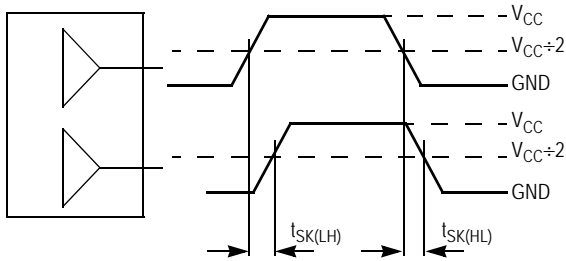

Figure 8. Propagation Delay (t_{PD}) Test Reference



The pin-to-pin skew is defined as the worst case difference in propagation delay between any similar delay path within a single device.

Figure 9. Output-to-Output Skew $t_{SK(LH, HL)}$

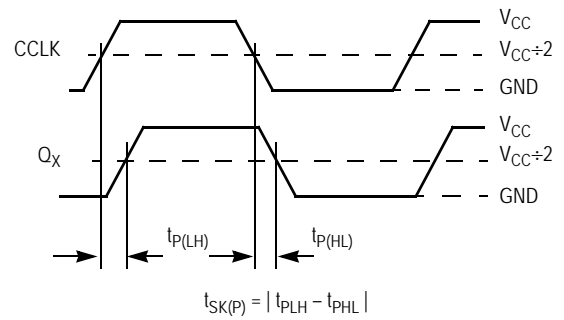
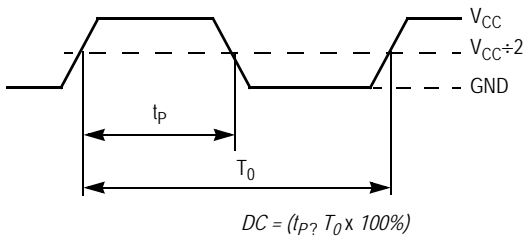

Figure 10. Output Pulse Skew ($t_{SK(P)}$) Test Reference



The time from the output controlled edge to the non-controlled edge, divided by the time between output controlled edges, expressed as a percentage.

Figure 11. Output Duty Cycle (DC)

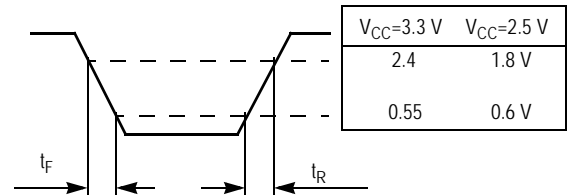
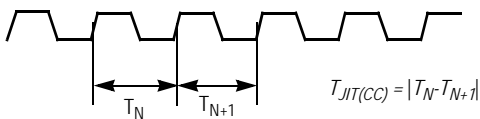

Figure 12. Output Transition Time Test Reference



The variation in cycle time of a signal between adjacent cycles, over a random sample of adjacent cycle pairs.

Figure 13. Cycle-to-Cycle Jitter

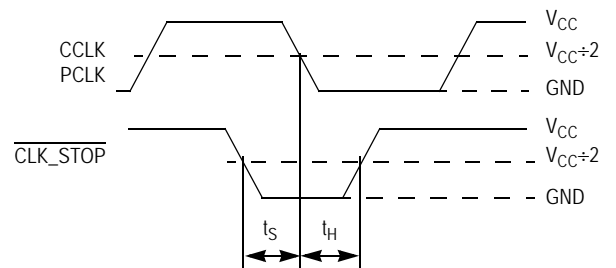
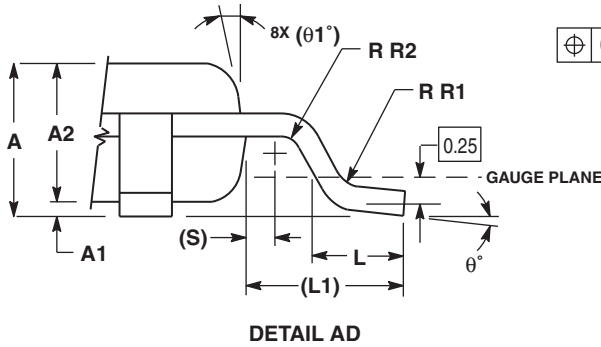
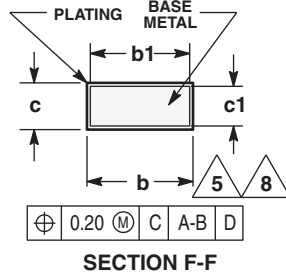
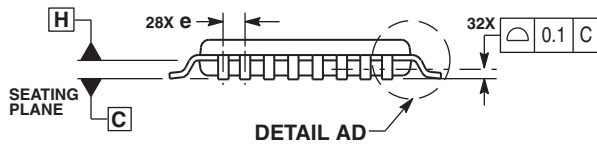
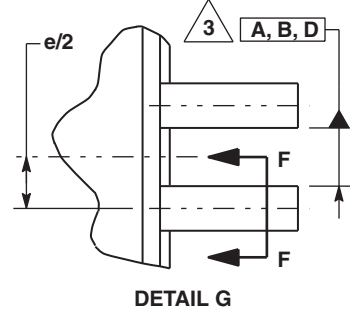
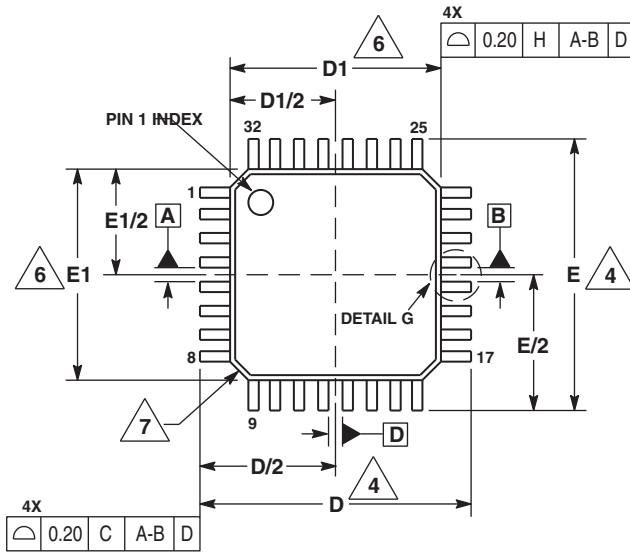

Figure 14. Setup and Hold Time (t_S, t_H) Test Reference

PACKAGE DIMENSIONS



- NOTES:
1. DIMENSIONS ARE IN MILLIMETERS.
 2. INTERPRET DIMENSIONS AND TOLERANCES PER ASME Y14.5M, 1994.
 3. DATUMS A, B, AND D TO BE DETERMINED AT DATUM PLANE H.
 4. DIMENSIONS D AND E TO BE DETERMINED AT SEATING PLANE C.
 5. DIMENSION b DOES NOT INCLUDE DAMBAR PROTRUSION. ALLOWABLE DAMBAR PROTRUSION SHALL NOT CAUSE THE LEAD WIDTH TO EXCEED THE MAXIMUM b DIMENSION BY MORE THAN 0.08-mm. DAMBAR CANNOT BE LOCATED ON THE LOWER RADIUS OR THE FOOT. MINIMUM SPACE BETWEEN PROTRUSION AND ADJACENT LEAD OR PROTRUSION: 0.07-mm.
 6. DIMENSIONS D1 AND E1 DO NOT INCLUDE MOLD PROTRUSION. ALLOWABLE PROTRUSION IS 0.25-mm PER SIDE. D1 AND E1 ARE MAXIMUM PLASTIC BODY SIZE DIMENSIONS INCLUDING MOLD MISMATCH.
 7. EXACT SHAPE OF EACH CORNER IS OPTIONAL.
 8. THESE DIMENSIONS APPLY TO THE FLAT SECTION OF THE LEAD BETWEEN 0.1-mm AND 0.25-mm FROM THE LEAD TIP.

DIM	MILLIMETERS	
	MIN	MAX
A	1.40	1.60
A1	0.05	0.15
A2	1.35	1.45
b	0.30	0.45
b1	0.30	0.40
c	0.09	0.20
c1	0.09	0.16
D	9.00	BSC
D1	7.00	BSC
e	0.80	BSC
E	9.00	BSC
E1	7.00	BSC
L	0.50	0.70
L1	1.00	REF
q	0°	7°
q1	12	REF
R1	0.08	0.20
R2	0.08	---
S	0.20	REF

CASE 873A-03
ISSUE B
32-LEAD LQFP PACKAGE

REVISION HISTORY SHEET

Rev	Table	Page	Description of Change	Date
7	T6, T8	1	Functional Description - corrected pin name CLK_STOP to $\overline{\text{CLK_STOP}}$.	9/12/11
		2	Logic Diagram (fig 1) - corrected pin name CLK_STOP to $\overline{\text{CLK_STOP}}$ and deleted bar from pin 1, 2, 3, 4, 6, 9, 11, 20, 25.	
		4, 5	AC Characteristics table - corrected pin name CLK_STOP to $\overline{\text{CLK_STOP}}$.	
		6	Figure 3 Diagram and Title - corrected pin name CLK_STOP to $\overline{\text{CLK_STOP}}$.	
8		1	Removed leaded part information	11/16/12
8		1	NRND – Not Recommend for New Designs	12/21/12
9		1	Removed NRND and updated data sheet format	3/18/15
9		1	Product Discontinuation Notice - Last time buy expires September 7, 2016. PDN N-16-02	3/15/16

IMPORTANT NOTICE AND DISCLAIMER

RENESAS ELECTRONICS CORPORATION AND ITS SUBSIDIARIES (“RENESAS”) PROVIDES TECHNICAL SPECIFICATIONS AND RELIABILITY DATA (INCLUDING DATASHEETS), DESIGN RESOURCES (INCLUDING REFERENCE DESIGNS), APPLICATION OR OTHER DESIGN ADVICE, WEB TOOLS, SAFETY INFORMATION, AND OTHER RESOURCES “AS IS” AND WITH ALL FAULTS, AND DISCLAIMS ALL WARRANTIES, EXPRESS OR IMPLIED, INCLUDING, WITHOUT LIMITATION, ANY IMPLIED WARRANTIES OF MERCHANTABILITY, FITNESS FOR A PARTICULAR PURPOSE, OR NON-INFRINGEMENT OF THIRD-PARTY INTELLECTUAL PROPERTY RIGHTS.

These resources are intended for developers who are designing with Renesas products. You are solely responsible for (1) selecting the appropriate products for your application, (2) designing, validating, and testing your application, and (3) ensuring your application meets applicable standards, and any other safety, security, or other requirements. These resources are subject to change without notice. Renesas grants you permission to use these resources only to develop an application that uses Renesas products. Other reproduction or use of these resources is strictly prohibited. No license is granted to any other Renesas intellectual property or to any third-party intellectual property. Renesas disclaims responsibility for, and you will fully indemnify Renesas and its representatives against, any claims, damages, costs, losses, or liabilities arising from your use of these resources. Renesas' products are provided only subject to Renesas' Terms and Conditions of Sale or other applicable terms agreed to in writing. No use of any Renesas resources expands or otherwise alters any applicable warranties or warranty disclaimers for these products.

(Disclaimer Rev.1.01 Jan 2024)

Corporate Headquarters

TOYOSU FORESIA, 3-2-24 Toyosu,
Koto-ku, Tokyo 135-0061, Japan
www.renesas.com

Trademarks

Renesas and the Renesas logo are trademarks of Renesas Electronics Corporation. All trademarks and registered trademarks are the property of their respective owners.

Contact Information

For further information on a product, technology, the most up-to-date version of a document, or your nearest sales office, please visit www.renesas.com/contact-us/.

Looking for pricing, stock, or lifecycle information?

Click below to explore more details on WIN SOURCE:

- ⊖ [View MPC9447ACR2](#) on WIN SOURCE
- ⊖ [Renesas Electronics America](#) Information

Optimize Your Supply Chain with WIN SOURCE Solutions

- ✓ Global Sourcing Solution
- ✓ Obsolete Management
- ✓ Cost Control Management
- ✓ Shortage Management
- ✓ Alternative Solution
- ✓ Excess Inventory Management