



THE DATASHEET OF SN74LS42NSR



SN5442A, SN54LS42, SN7442A, SN74LS42 4-LINE BCD TO 10-LINE DECIMAL DECODERS

SDLS109 – MARCH 1974 – REVISED MARCH 1988

- All Outputs Are High for Invalid Input Conditions
- Also for Application as
4-Line-to-16-Line Decoders
3-Line-to-8-Line Decoders
- Diode-Clamped Inputs

TYPES	TYPICAL POWER DISSIPATION	TYPICAL PROPAGATION DELAYS
'42A	140 mW	17 ns
'LS42	35 mW	17 ns

description

These monolithic BCD-to-decimal decoders consist of eight inverters and ten four-input NAND gates. The inverters are connected in pairs to make BCD input data available for decoding by the NAND gates. Full decoding of valid input logic ensures that all outputs remain off for all invalid input conditions.

The '42A and 'LS42 feature inputs and outputs that are compatible for use with most TTL and other saturated low-level logic circuits. DC noise margins are typically one volt.

The SN5442A and SN54LS42 are characterized for operation over the full military temperature range of -55°C to 125°C . The SN7442A and SN74LS42 are characterized for operation from 0°C to 70°C .

SN5442A, SN54LS42 . . . J OR W PACKAGE
SN7442A . . . N PACKAGE
SN74LS42 . . . D OR N PACKAGE
(TOP VIEW)

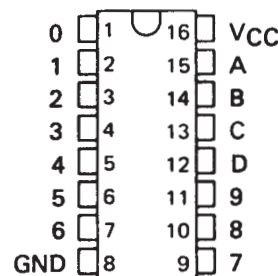

SN54LS42 . . . FK PACKAGE
(TOP VIEW)

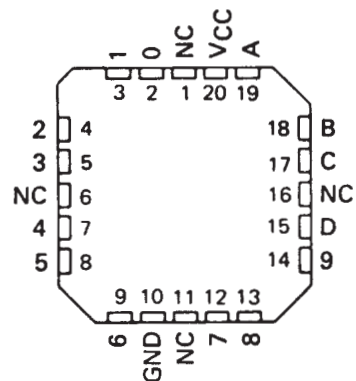

NC - No internal connection

SN5442A, SN54LS42, SN7442A, SN74LS42 4-LINE BCD TO 10-LINE DECIMAL DECODERS

SDLS109 – MARCH 1974 – REVISED MARCH 1988

logic symbol†

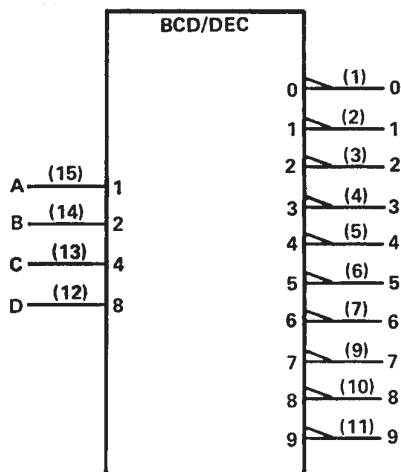

† This symbol is in accordance with ANSI/IEEE Std 91-1984 and IEC Publication 617-12.

logic diagram (positive logic)

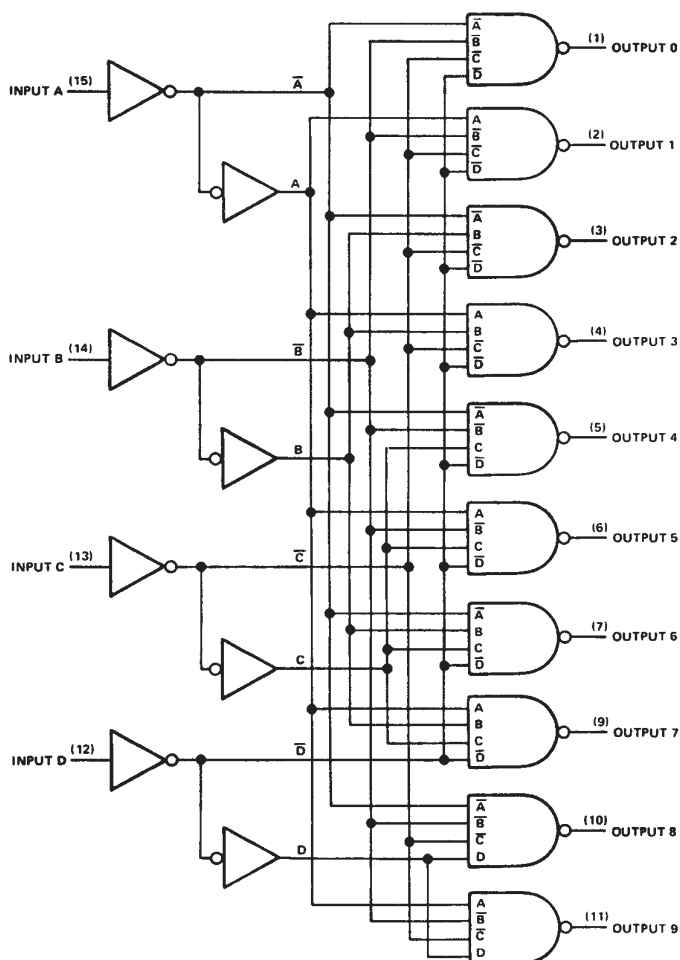

Pin numbers shown are for D, J, N, and W packages.



POST OFFICE BOX 655303 • DALLAS, TEXAS 75265

SN5442A, SN54LS42, SN7442A, SN74LS42
 4-LINE BCD TO 10-LINE DECIMAL DECODERS

SDLS109 – MARCH 1974 – REVISED MARCH 1988

schematics of inputs and outputs

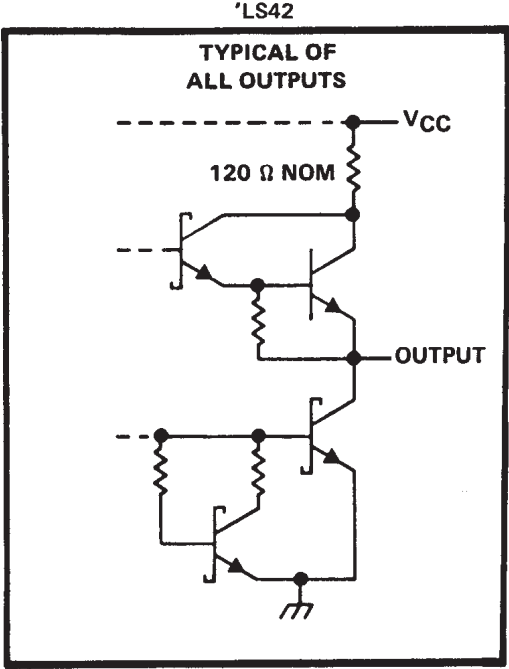
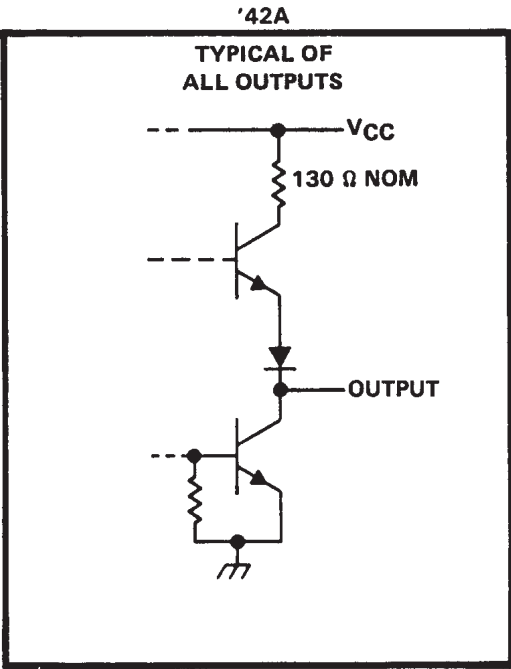
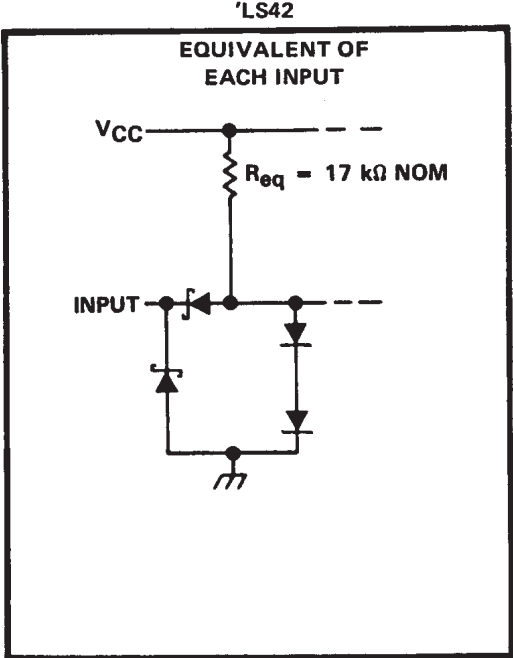
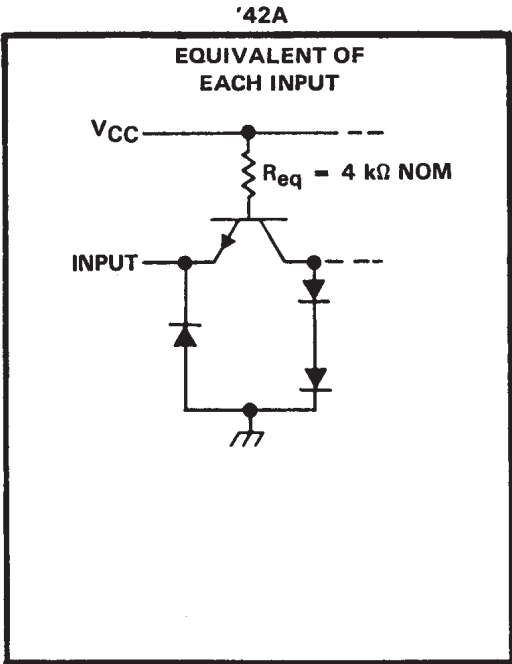

SN5442A, SN54LS42, SN7442A, SN74LS42

4-LINE BCD TO 10-LINE DECIMAL DECODERS

SDLS109 – MARCH 1974 – REVISED MARCH 1988

FUNCTION TABLE

NO.	BCD INPUT				DECIMAL OUTPUT									
	D	C	B	A	0	1	2	3	4	5	6	7	8	9
0	L	L	L	L	L	H	H	H	H	H	H	H	H	H
1	L	L	L	H	H	L	H	H	H	H	H	H	H	H
2	L	L	H	L	H	H	L	H	H	H	H	H	H	H
3	L	L	H	H	H	H	H	L	H	H	H	H	H	H
4	L	H	L	L	H	H	H	H	L	H	H	H	H	H
5	L	H	L	H	H	H	H	H	H	L	H	H	H	H
6	L	H	H	L	H	H	H	H	H	H	L	H	H	H
7	L	H	H	H	H	H	H	H	H	H	H	L	H	H
8	H	L	L	L	H	H	H	H	H	H	H	H	L	H
9	H	L	L	H	H	H	H	H	H	H	H	H	H	L
INVALID	H	L	H	L	H	H	H	H	H	H	H	H	H	H
	H	L	H	H	H	H	H	H	H	H	H	H	H	H
	H	H	L	L	H	H	H	H	H	H	H	H	H	H
	H	H	L	H	H	H	H	H	H	H	H	H	H	H
	H	H	H	L	H	H	H	H	H	H	H	H	H	H

H = high level, L = low level

absolute maximum ratings over operating free-air temperature range (unless otherwise noted)

- Supply voltage, V_{CC} (see Note 1) 7 V
- Input voltage: '42A 5.5 V
- 'LS42 7 V
- Operating free-air temperature range: SN5442A, SN54LS42 -55°C to 125°C
- SN7442A, SN74LS42 0°C to 70°C
- Storage temperature range -65°C to 150°C

NOTE 1: Voltage values are with respect to network ground terminal.



POST OFFICE BOX 655303 • DALLAS, TEXAS 75265

SN5442A, SN54LS42, SN7442A, SN74LS42 4-LINE BCD TO 10-LINE DECIMAL DECODERS

SDLS109 – MARCH 1974 – REVISED MARCH 1988

recommended operating conditions

	SN5442A			SN7442A			UNIT
	MIN	NOM	MAX	MIN	NOM	MAX	
Supply voltage, V_{CC}	4.5	5	5.5	4.75	5	5.25	V
High-level output current, I_{OH}			-800			-800	μ A
Low-level output current, I_{OL}			16			16	mA
Operating free-air temperature, T_A	-55		125	0		70	$^{\circ}$ C

electrical characteristics over recommended operating free-air temperature range (unless otherwise noted)

PARAMETER	TEST CONDITIONS [†]	SN5442A			SN7442A			UNIT
		MIN	TYP [‡]	MAX	MIN	TYP [‡]	MAX	
V_{IH} High-level input voltage		2			2			V
V_{IL} Low-level input voltage				0.8			0.8	V
V_{IK} Input clamp voltage	$V_{CC} = \text{MIN}, I_I = -12 \text{ mA}$			-1.5			-1.5	V
V_{OH} High-level output voltage	$V_{CC} = \text{MIN}, V_{IH} = 2 \text{ V}, V_{IL} = 0.8 \text{ V}, I_{OH} = -800 \mu\text{A}$	2.4	3.4		2.4	3.4		V
V_{OL} Low-level output voltage	$V_{CC} = \text{MIN}, V_{IH} = 2 \text{ V}, V_{IL} = 0.8 \text{ V}, I_{OL} = 16 \text{ mA}$		0.2	0.4		0.2	0.4	V
I_I Input current at maximum input voltage	$V_{CC} = \text{MAX}, V_I = 5.5 \text{ V}$			1			1	mA
I_{IH} High-level input current	$V_{CC} = \text{MAX}, V_I = 2.4 \text{ V}$			40			40	μ A
I_{IL} Low level input current	$V_{CC} = \text{MAX}, V_I = 0.4 \text{ V}$			-1.6			-1.6	mA
I_{OS} Short-circuit output current [§]	$V_{CC} = \text{MAX}$	-20		-55	-18		-55	mA
I_{CC} Supply current	$V_{CC} = \text{MAX}, \text{ See Note 2}$		28	41		28	56	mA

[†] For conditions shown as MIN or MAX, use the appropriate values specified under recommended operating conditions.

[‡] All typical values are at $V_{CC} = 5 \text{ V}, T_A = 25^{\circ}\text{C}$.

[§] Not more than one output should be shorted at a time.

NOTE 2: I_{CC} is measured with all outputs open and all inputs grounded.

switching characteristics, $V_{CC} = 5 \text{ V}, T_A = 25^{\circ}\text{C}$

PARAMETER	TEST CONDITIONS	MIN	TYP	MAX	UNIT
t_{PHL} Propagation delay time, high-to-low-level output from A, B, C, or D through 2 levels of logic	$C_L = 15 \text{ pF}, R_L = 400 \Omega,$ See Note 3		14	25	ns
t_{PHL} Propagation delay time, high-to-low-level output from A, B, C, or D through 3 levels of logic			17	30	ns
t_{PLH} Propagation delay time, low-to-high-level output from A, B, C, and D through 2 levels of logic			10	25	ns
t_{PLH} Propagation delay time, low-to-high-level output from A, B, C, and D through 3 levels of logic			17	30	ns

NOTE 3: Load circuits and voltage waveforms are shown in Section 1.

SN5442A, SN54LS42, SN7442A, SN74LS42

4-LINE BCD TO 10-LINE DECIMAL DECODERS

SDLS109 – MARCH 1974 – REVISED MARCH 1988

recommended operating conditions

	SN54LS42			SN74LS42			UNIT
	MIN	NOM	MAX	MIN	NOM	MAX	
Supply voltage, V_{CC}	4.5	5	5.5	4.75	5	5.25	V
High-level output current, I_{OH}			-400			-400	μ A
Low-level output current, I_{OL}			4			8	mA
Operating free-air temperature, T_A	-55		125	0		70	$^{\circ}$ C

electrical characteristics over recommended operating free-air temperature range (unless otherwise noted)

PARAMETER	TEST CONDITIONS†	SN54LS42			SN74LS42			UNIT	
		MIN	TYP‡	MAX	MIN	TYP‡	MAX		
V_{IH} High-level input voltage		2			2			V	
V_{IL} Low-level input voltage				0.7			0.8	V	
V_{IK} Input clamp voltage	$V_{CC} = \text{MIN}, I_I = -18 \text{ mA}$			-1.5			-1.5	V	
V_{OH} High-level output voltage	$V_{CC} = \text{MIN}, V_{IH} = 2 \text{ V}, V_{IL} = V_{IL \text{ max}}, I_{OH} = -400 \mu\text{A}$	2.5	3.5		2.7	3.5		V	
V_{OL} Low-level output voltage	$V_{CC} = \text{MIN}, V_{IH} = 2 \text{ V}, V_{IL} = V_{IL \text{ max}}$	$I_{OL} = 4 \text{ mA}$		0.25	0.4	0.25	0.4	V	
		$I_{OL} = 8 \text{ mA}$				0.35	0.5		
I_I Input current at maximum input voltage	$V_{CC} = \text{MAX}, V_I = 7 \text{ V}$			0.1			0.1	mA	
I_{IH} High-level input current	$V_{CC} = \text{MAX}, V_I = 2.7 \text{ V}$			20			20	μ A	
I_{IL} Low-level input current	$V_{CC} = \text{MAX}, V_I = 0.4 \text{ V}$			-0.4			-0.4	mA	
I_{OS} Short-circuit output current §	$V_{CC} = \text{MAX}$	-20		-100		-20		-100	mA
I_{CC} Supply current	$V_{CC} = \text{MAX}, \text{ See Note 2}$		7	13		7	13	mA	

†For conditions shown as MIN or MAX, use the appropriate value specified under recommended operating conditions.

‡All typical values are at $V_{CC} = 5 \text{ V}, T_A = 25^{\circ}\text{C}$.

§Not more than one output should be shorted at a time, and duration of the short-circuit should not exceed one second.

NOTE 2. I_{CC} is measured with all outputs open and inputs grounded.

switching characteristics, $V_{CC} = 5 \text{ V}, T_A = 25^{\circ}\text{C}$

PARAMETER	TEST CONDITIONS	MIN	TYP	MAX	UNIT
t_{PHL} Propagation delay time, high-to-low-level output from A, B, C, or D through 2 levels of logic	$C_L = 15 \text{ pF}, R_L = 2 \text{ k}\Omega, \text{ See Note 3}$		15	25	ns
t_{PHL} Propagation delay time, high-to-low-level output from A, B, C, or D through 3 levels of logic			20	30	ns
t_{PLH} Propagation delay time, low-to-high-level output from A, B, C, and D through 2 levels of logic			15	25	ns
t_{PLH} Propagation delay time, low-to-high-level output from A, B, C, and D through 3 levels of logic			20	30	ns

NOTE 3: Load circuits and voltage waveforms are shown in Section 1.



IMPORTANT NOTICE

Texas Instruments Incorporated and its subsidiaries (TI) reserve the right to make corrections, modifications, enhancements, improvements, and other changes to its products and services at any time and to discontinue any product or service without notice. Customers should obtain the latest relevant information before placing orders and should verify that such information is current and complete. All products are sold subject to TI's terms and conditions of sale supplied at the time of order acknowledgment.

TI warrants performance of its hardware products to the specifications applicable at the time of sale in accordance with TI's standard warranty. Testing and other quality control techniques are used to the extent TI deems necessary to support this warranty. Except where mandated by government requirements, testing of all parameters of each product is not necessarily performed.

TI assumes no liability for applications assistance or customer product design. Customers are responsible for their products and applications using TI components. To minimize the risks associated with customer products and applications, customers should provide adequate design and operating safeguards.

TI does not warrant or represent that any license, either express or implied, is granted under any TI patent right, copyright, mask work right, or other TI intellectual property right relating to any combination, machine, or process in which TI products or services are used. Information published by TI regarding third-party products or services does not constitute a license from TI to use such products or services or a warranty or endorsement thereof. Use of such information may require a license from a third party under the patents or other intellectual property of the third party, or a license from TI under the patents or other intellectual property of TI.

Reproduction of TI information in TI data books or data sheets is permissible only if reproduction is without alteration and is accompanied by all associated warranties, conditions, limitations, and notices. Reproduction of this information with alteration is an unfair and deceptive business practice. TI is not responsible or liable for such altered documentation. Information of third parties may be subject to additional restrictions.

Resale of TI products or services with statements different from or beyond the parameters stated by TI for that product or service voids all express and any implied warranties for the associated TI product or service and is an unfair and deceptive business practice. TI is not responsible or liable for any such statements.

TI products are not authorized for use in safety-critical applications (such as life support) where a failure of the TI product would reasonably be expected to cause severe personal injury or death, unless officers of the parties have executed an agreement specifically governing such use. Buyers represent that they have all necessary expertise in the safety and regulatory ramifications of their applications, and acknowledge and agree that they are solely responsible for all legal, regulatory and safety-related requirements concerning their products and any use of TI products in such safety-critical applications, notwithstanding any applications-related information or support that may be provided by TI. Further, Buyers must fully indemnify TI and its representatives against any damages arising out of the use of TI products in such safety-critical applications.

TI products are neither designed nor intended for use in military/aerospace applications or environments unless the TI products are specifically designated by TI as military-grade or "enhanced plastic." Only products designated by TI as military-grade meet military specifications. Buyers acknowledge and agree that any such use of TI products which TI has not designated as military-grade is solely at the Buyer's risk, and that they are solely responsible for compliance with all legal and regulatory requirements in connection with such use.

TI products are neither designed nor intended for use in automotive applications or environments unless the specific TI products are designated by TI as compliant with ISO/TS 16949 requirements. Buyers acknowledge and agree that, if they use any non-designated products in automotive applications, TI will not be responsible for any failure to meet such requirements.

Following are URLs where you can obtain information on other Texas Instruments products and application solutions:

Products

Audio	www.ti.com/audio
Amplifiers	amplifier.ti.com
Data Converters	dataconverter.ti.com
DLP® Products	www.dlp.com
DSP	dsp.ti.com
Clocks and Timers	www.ti.com/clocks
Interface	interface.ti.com
Logic	logic.ti.com
Power Mgmt	power.ti.com
Microcontrollers	microcontroller.ti.com
RFID	www.ti-rfid.com
RF/IF and ZigBee® Solutions	www.ti.com/lprf

Applications

Communications and Telecom	www.ti.com/communications
Computers and Peripherals	www.ti.com/computers
Consumer Electronics	www.ti.com/consumer-apps
Energy and Lighting	www.ti.com/energy
Industrial	www.ti.com/industrial
Medical	www.ti.com/medical
Security	www.ti.com/security
Space, Avionics and Defense	www.ti.com/space-avionics-defense
Transportation and Automotive	www.ti.com/automotive
Video and Imaging	www.ti.com/video
Wireless	www.ti.com/wireless-apps

TI E2E Community Home Page

e2e.ti.com

Mailing Address: Texas Instruments, Post Office Box 655303, Dallas, Texas 75265
Copyright © 2011, Texas Instruments Incorporated

Looking for pricing, stock, or lifecycle information?

Click below to explore more details on WIN SOURCE:

- ⊖ [View SN74LS42NSR on WIN SOURCE](#)
- ⊖ [Texas Instruments Information](#)

Optimize Your Supply Chain with WIN SOURCE Solutions

- ✓ Global Sourcing Solution
- ✓ Obsolete Management
- ✓ Cost Control Management
- ✓ Shortage Management
- ✓ Alternative Solution
- ✓ Excess Inventory Management