



**THE DATASHEET OF  
AS1507-BTDT-100**



# AS1507

## Dual 256-Tap Digital Potentiometer with SPI Interface and High Endurance EEPROM

### 1 General Description

The AS1507 is a linear, dual 256-tap digital potentiometer specifically designed to replace discrete/mechanical potentiometers and is ideal for applications requiring a low-temperature-coefficient variable resistor.

The device is controlled via a 3-wire SPI-compatible interface and features an internal EEPROM for storing wiper positions.

Several device variants are available differentiated by end-to-end resistance as shown in [Table 1](#) (see also [Ordering Information on page 17](#)).

Table 1. Standard Products

Model	End-to-End Resistance (kΩ)
AS1507-10	10
AS1507-50	50
AS1507-100	100

The 3-wire SPI-compatible serial interface allows communication at data rates up to 5MHz. The internal EEPROM stores the last wiper position for initialization during power-up.

The devices are available in an TQFN 3x3mm 16-pin package.

### 2 Key Features

- High Endurance: EEPROM up to 10M cycles
- High Reliability: EEPROM up to 150 years data retention @ 85°C
- Wiper Position Retained in EEPROM and loaded at Power-Up
- 256 Tap Positions
- ±0.5LSB DNL in Voltage Divider Mode
- ±0.5LSB INL in Voltage Divider Mode
- End-to-End Resistance: 10/50/100kΩ
- Low End-to-End Resistance Temperature Coefficient: 90ppm/°C
- Low-Power Standby Mode: 100nA
- 5MHz SPI-Compatible Serial Interface
- Single-Supply Operation: +2.7 to +5.5V
- TQFN 3x3mm 16-pin Package

### 3 Applications

The device is ideal for mechanical potentiometer replacement, low-drift programmable gain amplifiers, audio volume control, LCD contrast control, and low-drift programmable filters.

Figure 1. AS1507 - Block Diagram

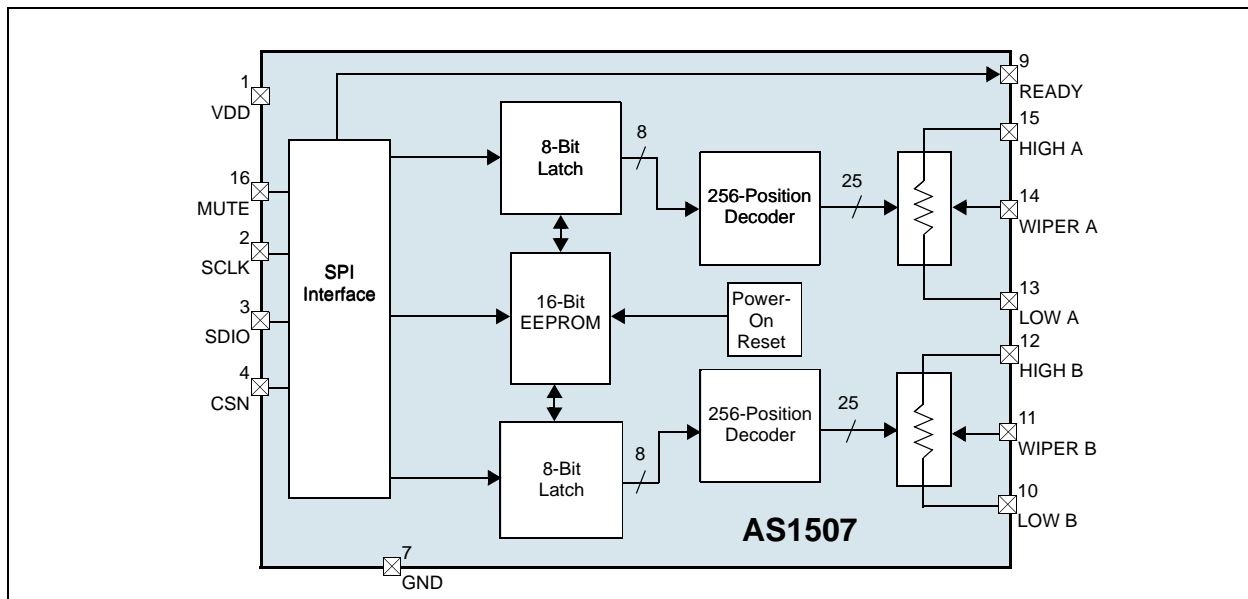

## 4 Pinout

### Pin Assignments

Figure 2. Pin Assignments (Top View)

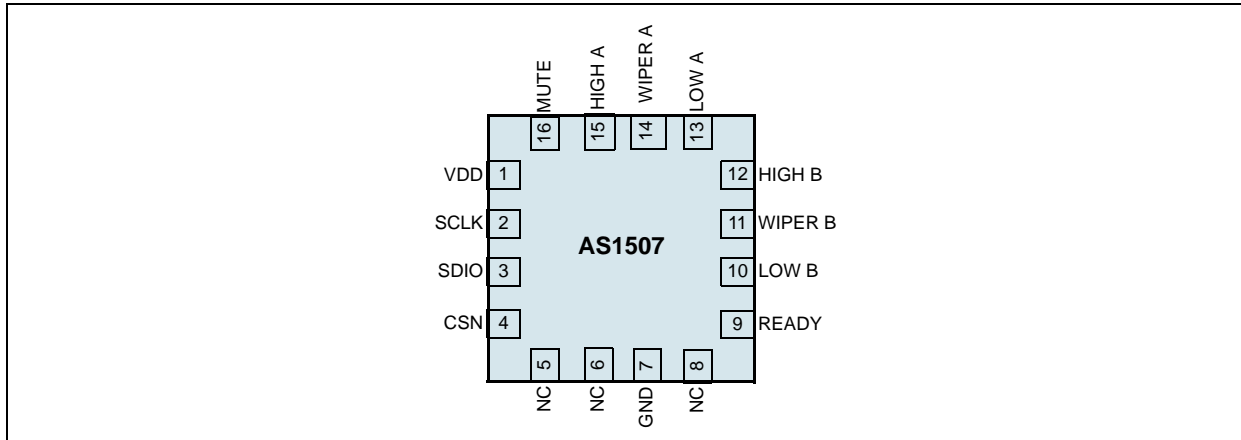

### Pin Descriptions

Table 2. Pin Descriptions

Pin Number	Pin Name	Description
1	VDD	<b>2.5V to 5.5V Supply Voltage.</b> Bypass with a 0.1µF capacitor to GND.
2	SCLK	<b>Serial Clock Input</b>
3	SDIO	<b>Serial Data Input</b>
4	CSN	<b>Active-Low Chip Select</b>
5, 6, 8	NC	<b>Not Connected</b>
7	GND	<b>Ground</b>
9	READY	<b>EEPROM Ready.</b> Active-Low indicates an ongoing write operation in the EEPROM.
10	LOW B	<b>Low Terminal of Resistor B.</b> The voltage at this pin can be greater than or less than the voltage at pin HIGH. Current can flow into or out of this pin.
11	WIPER B	<b>Wiper Terminal for Resistor B</b>
12	HIGH B	<b>High Terminal of Resistor B.</b> The voltage at this pin can be greater than or less than the voltage at pin LOW. Current can flow into or out of this pin.
13	LOW A	<b>Low Terminal of Resistor A.</b> The voltage at this pin can be greater than or less than the voltage at pin HIGH. Current can flow into or out of this pin.
14	WIPER A	<b>Wiper Terminal for Resistor A</b>
15	HIGH A	<b>High Terminal of Resistor A.</b> The voltage at this pin can be greater than or less than the voltage at pin LOW. Current can flow into or out of this pin.
16	MUTE	<b>Mute.</b> Both wiper registers are asynchronously set to zero. Data stored in the EEPROM is not affected. Active-High signal. Internal pull-down resistor. Can be left unconnected if not used.
N/A	Exposed Pad	The exposed pad is not internally connected. Connect to GND or leave floating.

## 5 Absolute Maximum Ratings

Stresses beyond those listed in [Table 3](#) may cause permanent damage to the device. These are stress ratings only, and functional operation of the device at these or any other conditions beyond those indicated in [Electrical Characteristics on page 4](#) is not implied. Exposure to absolute maximum rating conditions for extended periods may affect device reliability.

Table 3. Absolute Maximum Ratings

Parameter		Min	Max	Units	Comments
V <sub>DD</sub> to GND		-0.3	+7.0	V	
All Other Pins to GND		-0.3	V <sub>DD</sub> + 0.3	V	
Maximum Continuous Current into Pins HIGH, WIPER, and LOW	AS1507-10	+1		mA	
	AS1507-50	+1			
	AS1507-100	+1			
Electrostatic Discharge		1		kV	HBM MIL-Std. 883E 3015.7 methods
Latch-Up <sup>1</sup>		-100	100	mA	JEDEC 78
Thermal Resistance $\Theta_{JA}$		48		°C/W	on PCB
Operating Temperature Range		-40	+85	°C	
Storage Temperature Range		-60	+150	°C	
Junction Temperature			+150	°C	
Package Body Temperature			+260	°C	The reflow peak soldering temperature (body temperature) specified is in accordance with IPC/JEDEC J-STD-020D "Moisture/Reflow Sensitivity Classification for Non-Hermetic Solid State Surface Mount Devices". The lead finish for Pb-free leaded packages is matte tin (100% Sn).

1. The maximum rating voltage must not be exceeded during Latch-up test of the device.

## 6 Electrical Characteristics

$V_{DD} = +2.7$  to  $+5.5V$ ,  $HIGH = V_{DD}$ ,  $LOW = GND$ ,  $T_{AMB} = -40$  to  $+85^{\circ}C$ . *Typ values are at  $V_{DD} = +5.0V$ ,  $T_{AMB} = +25^{\circ}C$  (unless otherwise specified).*

Table 4. Electrical Characteristics

Symbol	Parameter	Condition	Min	Typ	Max	Unit
<b>Power Supply</b>						
$V_{DD}$			2.70		5.5	V
$I_{DD}$	Standby Current	Digital Inputs = $V_{DD}$ or $GND$ , $T_{AMB} = +25^{\circ}C$		0.1	0.5	$\mu A$
$I_{OP}$	Operating Current (CMOS write)	Includes Non-Volatile Write to Memory <sup>1</sup>		110	200	$\mu A$
<b>DC Performance (Voltage Divider Mode)</b>						
N	Resolution		256			Taps
INL	Integral Linearity <sup>2</sup>	AS1507-10		$\pm 0.5$	$\pm 1$	LSB
		AS1507-50 & -100		$\pm 0.25$	$\pm 0.5$	
DNL	Differential Non-Linearity <sup>2</sup>	AS1507-10		$\pm 0.5$	$\pm 1$	LSB
		AS1507-50 & -100		$\pm 0.25$	$\pm 0.5$	
TCR	End-to-End Resistance Temperature Coefficient	$T_{AMB} = 0$ to $+85^{\circ}C$		90		ppm/ $^{\circ}C$
	Full Scale Error	AS1507-10		2.5	4	LSB
		AS1507-50		1.5	2.5	
		AS1507-100		1.5	2.5	
	Zero Scale Error	AS1507-10		1	2	LSB
		AS1507-50		0.1	0.7	
		AS1507-100		0.1	0.7	
<b>DC Performance (Variable Resistor Mode)</b>						
INL	Integral Linearity <sup>3</sup>	AS1507-10		$\pm 1$	$\pm 2$	LSB
		AS1507-50 & -100 @ 3V		$\pm 0.6$	$\pm 1.5$	
		AS1507-50 & -100 @ 5V		$\pm 0.5$	$\pm 1$	
DNL	Differential Non-Linearity	AS1507-10		$\pm 0.5$	$\pm 1$	LSB
		AS1507-50 & -100		$\pm 0.5$	$\pm 1$	
<b>DC Performance (Resistor Characteristics)</b>						
RW	Wiper Resistance <sup>4</sup>	$V_{DD} = 3V$		200		$\Omega$
		$V_{DD} = 5V$		120		
CW	Wiper Capacitance			15		pF
REE	End-to-End Resistance	AS1507-10	7.5	10	12.5	k $\Omega$
		AS1507-50	37.5	50	62.5	
		AS1507-100	75	100	125	
<b>Inputs and Outputs</b>						
	WIPER Voltage Range		GND-0.3		$V_{DD}+0.3$	V
	HIGH Voltage Range					
	LOW Voltage Range					
$V_{IH}$	Digital Input High Voltage <sup>5</sup>	$V_{DD} = 3V$	2.1			V
		$V_{DD} = 5V$	2.4			
$V_{IL}$	Digital Input Low Voltage <sup>5</sup>	$V_{DD} = 3V$			0.6	V
		$V_{DD} = 5V$			0.8	
$I_{LEAK}$	Digital Input Leakage Current			200	500	nA
$C_{IN}$	Digital Input Capacitance			5		pF
$I_{CONT}$	Continuous DAC current				1000	$\mu A$

Table 4. Electrical Characteristics (Continued)

Symbol	Parameter	Condition	Min	Typ	Max	Unit
<b>Dynamic Characteristics</b>						
	Wiper -3dB Bandwidth <sup>6</sup>	AS1507-10		1200		kHz
		AS1507-50		220		
		AS1507-100		120		
ts	Wiper Settling Time <sup>7</sup>	AS1507-10		1100		ns
		AS1507-50		1600		
		AS1507-100		2200		
<b>Non-Volatile Memory Reliability</b>						
	Data Retention <sup>8</sup>	T <sub>AMB</sub> = +85°C		150		Years
	Endurance <sup>8</sup>	T <sub>AMB</sub> = +25°C		10M		Write Cycles
		T <sub>AMB</sub> = +85°C		1M		
t <sub>BUSY</sub>	Write Non-Volatile Register Busy Time				20	ms

- The programming current operates only during power-up and non-volatile memory writes.
- DNL and INL are measured with the potentiometer configured as a voltage-divider with HIGH = V<sub>DD</sub> and LOW = GND. The wiper terminal is unloaded and measured with a high-input-impedance voltmeter.
- DNL and INL are measured with the potentiometer configured as a variable resistor. HIGH is unconnected and LOW = GND. For the 5V condition, the wiper terminal is driven with a source current of 400µA @ 10kΩ, 80µA @ 50kΩ, 40µA @ 100kΩ. In 3V conditions, the wiper terminal is driven with a source current of 200µA @ 10kΩ, 40µA @ 50kΩ, 20µA @ 100kΩ.
- The wiper resistance is measured using the source currents given in Note 3. The number is the worst case resistance over TAP positions.
- The device draws higher supply current when the digital inputs are driven with voltages between (V<sub>DD</sub> - 0.5V) and (GND + 0.5V).
- Wiper at midscale with a 10pF load (DC measurement) V<sub>DD</sub> = 5V, LOW = GND. An AC source (5V peak to peak sinus signal) is applied to HIGH and the WIPER output is measured. A 3dB bandwidth occurs when the AC WIPER/HIGH value is 3dB lower than the DC WIPER/HIGH value.
- Wiper-settling time is the worst-case 0 to 50% rise-time measured between successive wiper positions. HIGH = V<sub>DD</sub>, LOW = GND; WIPER is unloaded and measured with a 10pF load.
- This parameter is not tested but ensured by characterization.

**Note:** All limits are guaranteed. The parameters with min and max values are guaranteed with production tests or SQC (Statistical Quality Control) methods.

## Timing Characteristics

$V_{DD} = +2.7$  to  $+5.5V$ ,  $HIGH = V_{DD}$ ,  $LOW = GND$ ,  $T_{AMB} = -40$  to  $+85^{\circ}C$ . Typ values are at  $V_{DD} = +5.0V$ ,  $T_{AMB} = +25^{\circ}C$  (unless otherwise specified). See [Figure 20 on page 10](#). Digital timing data is guaranteed by design and characterization, and is not production tested.

Table 5. Timing Characteristics

Symbol	Parameter	Condition	Min	Typ	Max	Unit
fSCLK	SCLK Frequency				5	MHz
tCP	SCLK Clock Period		200			ns
tCH	SCLK Pulse-Width High		40			ns
tCL80	SCLK Pulse-Width Low		40			ns
tCSS	CSN-Fall to SCLK Rise Setup		40			ns
tCSH	SCLK-Rise to CSN-Rise Hold		40			ns
tDS	SDIO to SCLK Setup		10			ns
tDH	SDIO Hold after SCLK		0			ns
tCS0	SCLK-Rise to CSN-Fall Delay		40			ns
tCS1	CSN-Rise to SCLK-Rise Hold		40			ns
tCSW	CSN Pulse-Width High		200			ns
tBUSY	Write Non-Volatile Register Busy Time				20	ms

## 7 Typical Operating Characteristics

VDD = 5V (unless otherwise specified).

Figure 3. DNL vs. TAP Position 10k $\Omega$ , Divider Mode

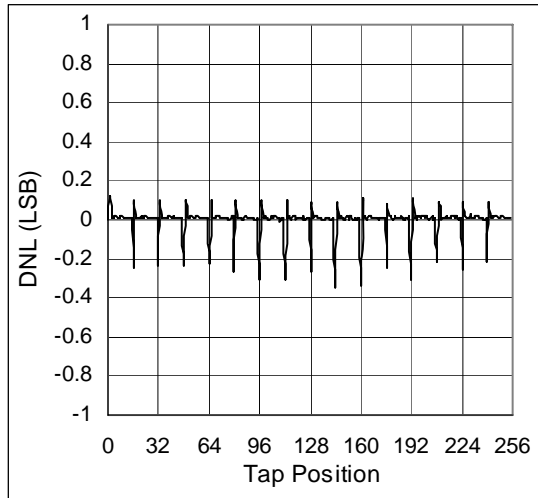

Figure 4. INL vs. TAP Position 10k $\Omega$ , Divider Mode

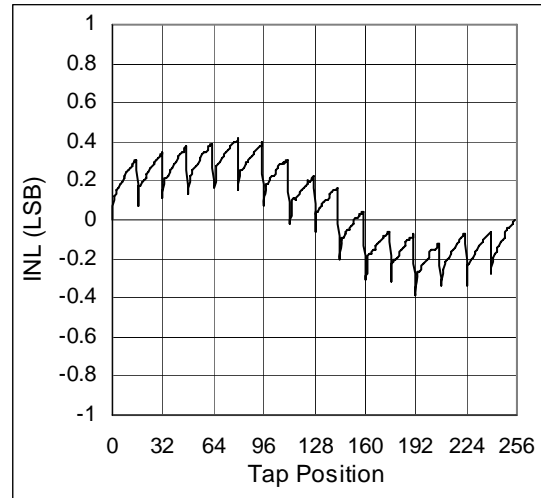

Figure 5. DNL vs. TAP Position 50k $\Omega$ , Divider Mode

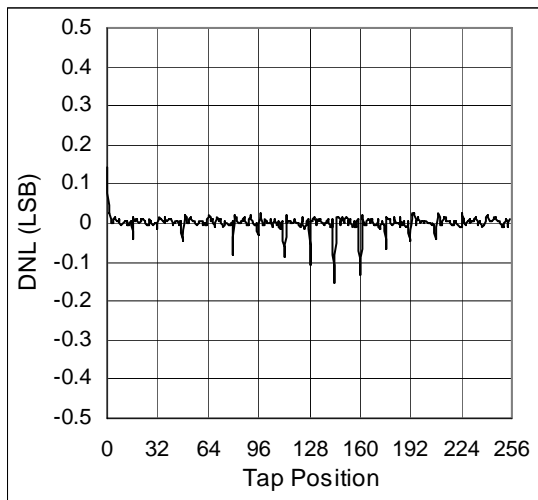

Figure 6. INL vs. TAP Position 50k $\Omega$ , Divider Mode

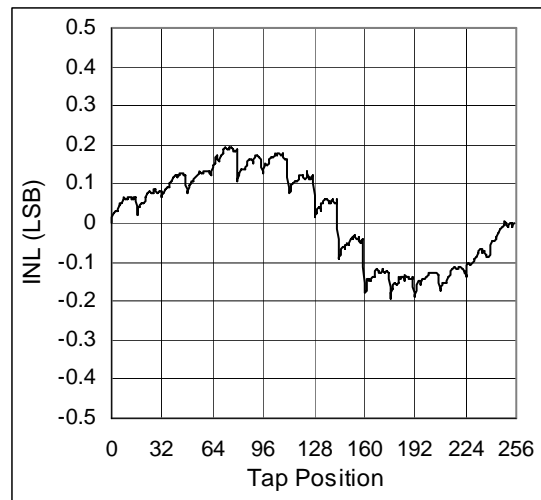

Figure 7. DNL vs. TAP Position 100k $\Omega$ , Divider Mode

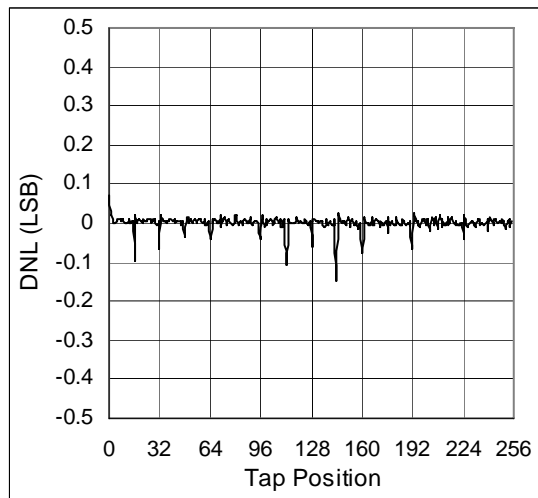

Figure 8. INL vs. TAP Position 100k $\Omega$ , Divider Mode

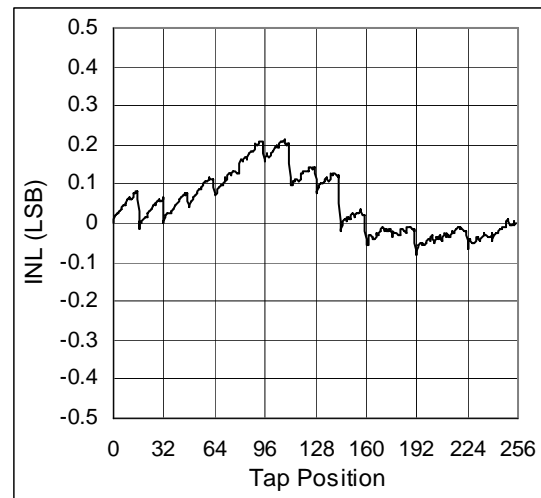

Figure 9. DNL vs. TAP Position 10kΩ, Varistor Mode

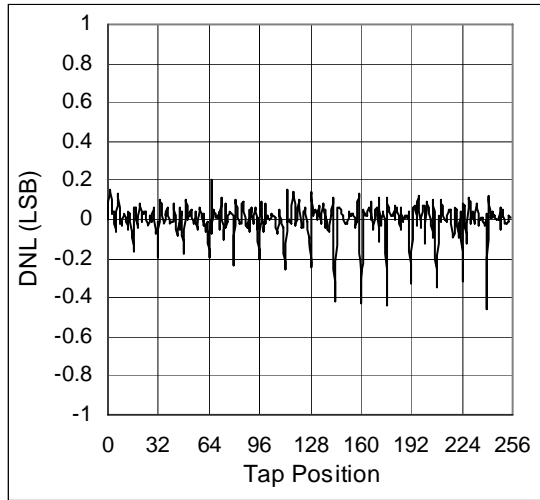

Figure 10. INL vs. TAP Position 10kΩ, Varistor Mode

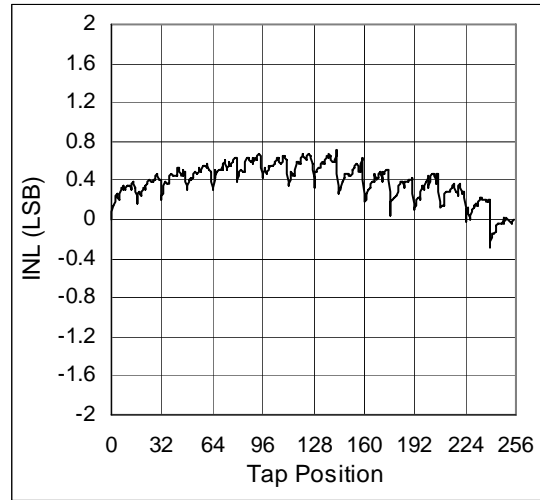

Figure 11. DNL vs. TAP Position 50kΩ, Varistor Mode

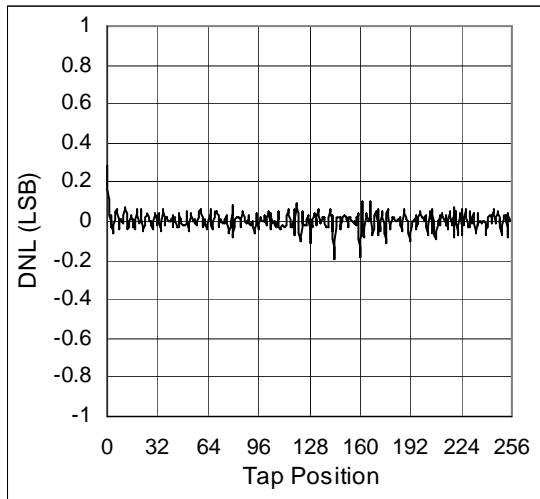

Figure 12. INL vs. TAP Position 50kΩ, Varistor Mode

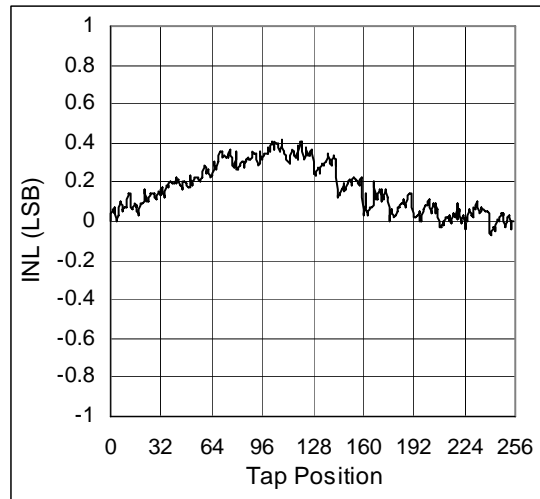

Figure 13. DNL vs. TAP Position 100kΩ, Varistor Mode

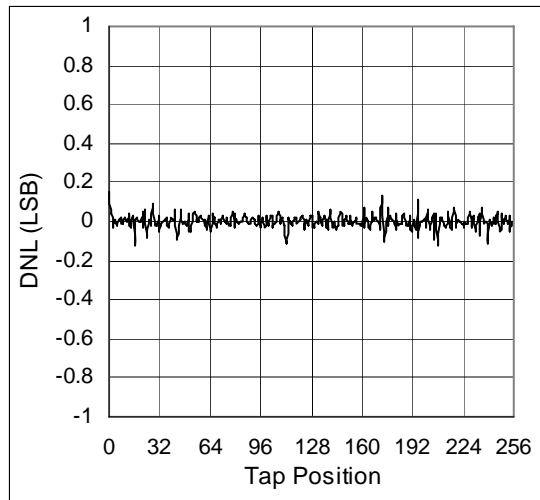

Figure 14. INL vs. TAP Position 100kΩ, Varistor Mode

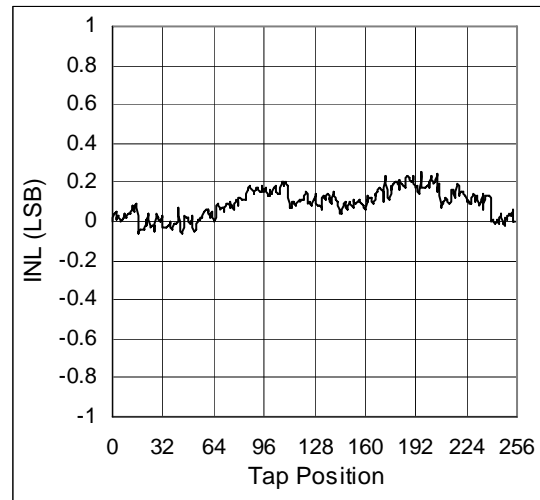

Figure 15. Wiper Resistance vs. TAP; 5V

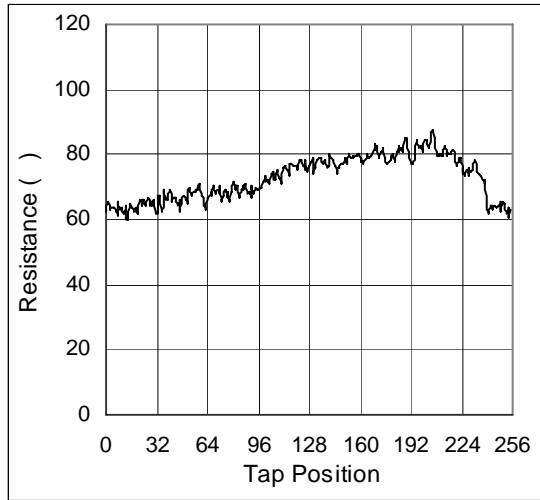

Figure 16. Wiper Resistance vs. TAP; 3V

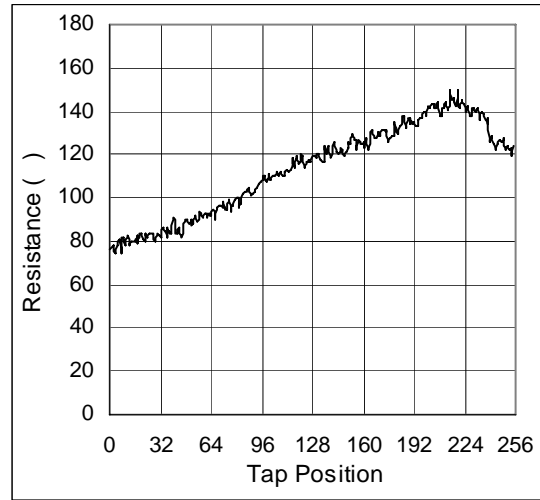

Figure 17. DAC Resistor vs. Temperature

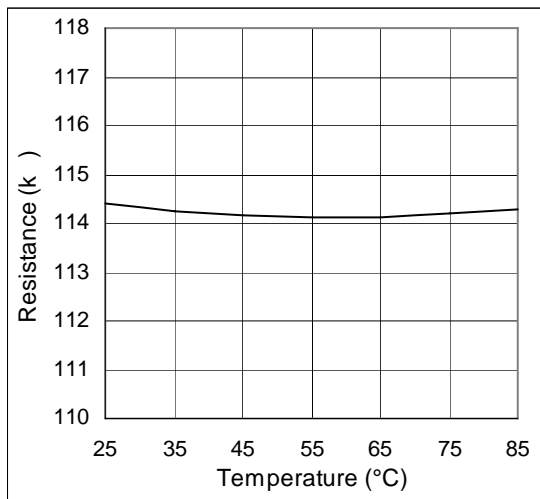

Figure 18. Gain vs. Bandwidth

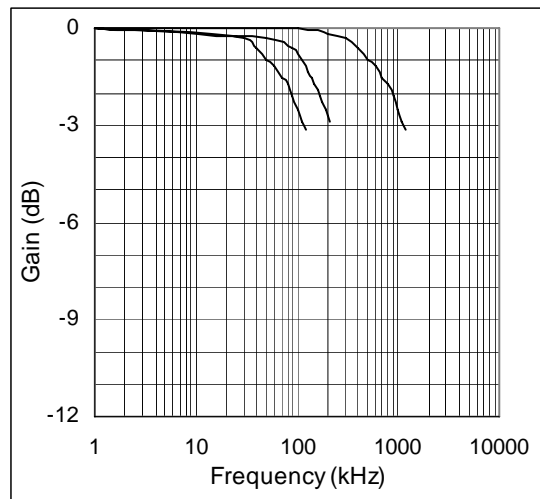
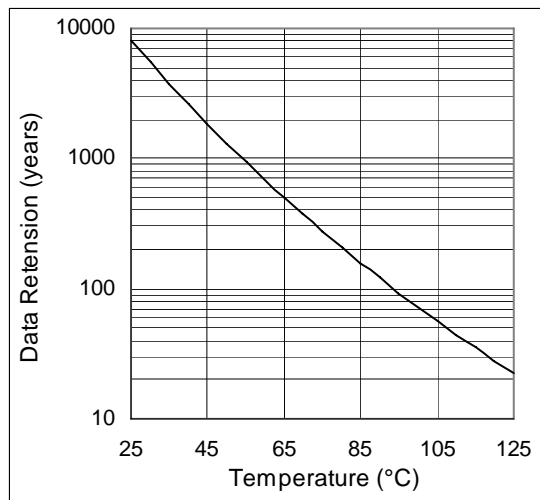

Figure 19. EEPROM Data Retention vs. Temperature



## 8 Detailed Description

The AS1507 contains two resistor arrays with 255 resistive elements each (tap points), and has a total end-to-end resistance of 10, 50, or 100k $\Omega$  (see [Ordering Information on page 17](#)).

The device provides high, low, and wiper terminals for a standard voltage-divider configuration. Pins HIGH, LOW, and WIPER can be connected in any configuration as long as their voltages fall between GND and VDD.

A 3-wire, SPI-compatible serial interface controls movement of the wiper among the 256 tap points. The EEPROM stores the wiper position and recalls the stored wiper position upon power-up. The EEPROM typically holds wiper data for 150 years and up to 10M wiper store cycles.

### Analog Circuit

The 256 tap points are accessible to the wiper along the resistor string between pins HIGH and LOW (similar to the end terminals of a mechanical potentiometer). The wiper tap point is selected by programming 8 data bits and a control byte via the 3-wire serial interface (see [Programming the Device on page 11](#)).

**Note:** Integrated power-on reset circuitry loads the wiper position from the EEPROM at power-up.

### Digital Interface

The AS1507 uses an SPI-compatible 3-wire interface for command settings of the device consisting of two input signals (chip-select - CSN, and data clock - SCLK) and one bi-directional data pin (SDIO). Driving CSN low enables serial interface and the command/data are passed into the device synchronously by each SCLK rising edge.

There are 16-bit commands for write data into the wiper register or the non-volatile memory, and 8-bit commands for transferring data between wiper register and non-volatile memory and to read the data stored in the wiper register or non-volatile memory. The 8-bit commands can be implemented in 16-bit command structure alternatively. In this case the first 8 bits shifted through the SPI interface are not significant. The data byte passed at writing commands represents the position of the wiper.

After loading the 8- or 16-bit command while CSN is low, the loaded command is executed at the next rising edge of CSN, simultaneously the serial interface is disabled. The CSN signal must be low during the whole serial input stream through the SPI, otherwise data on the SPI interface are corrupted.

**Note:** If the data-in stream does not exactly contain 8 or 16 digits, no command is executed at the rising edge of CSN.

Figure 20. Serial Data Timing

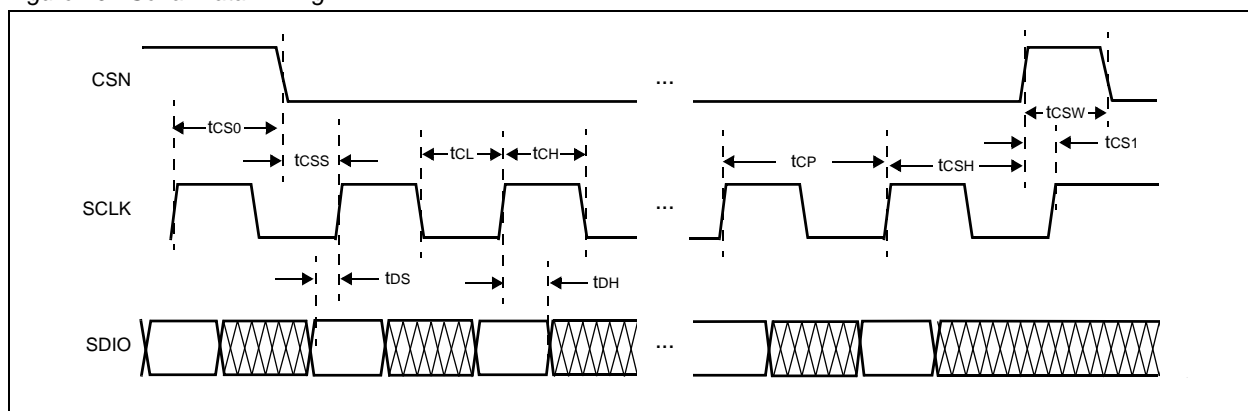

### Standby Mode

Low-power standby mode is enabled at CSN high. After a read access standby mode is entered 2 cycles of SCLK after issuing the last bit of the data wiper or non-volatile register. If the digital inputs are stable VDD or GND there is only leakage power dissipation of the device.

This power dissipation is defined with 0.1 $\mu$ A (typ) at 25 $^{\circ}$ C.

## EEPROM (Non-Volatile Register)

There is an internal EEPROM register implemented to retain the wiper position after power down. During an ongoing write cycle of the non-volatile register ( $t_{\text{BUSY}}$  time) the system must not be powered down. A write cycle on the EEPROM is indicated by the READY signal.

Data retention defines the ability of an EEPROM to retain data over time. The qualification has been done according to JEDEC Retention Lifetime Specification (A117). The EEPROM is cycled to the specified endurance limit before the data retention test is done. Based on activation energy of 0.6eV the data retention time derates over temperature as shown in [Figure 19 on page 9](#).

For the non-volatile register 1M endurance cycles and a data retention of 150 years are typical at 85 °C. The non-volatile register is factory trimmed to mid-scale.

## Power-Up

The AS1507 contains an integrated power-up circuit. At power up, the data are transferred from the non-volatile memory to the wiper register. The wiper register moves to the stored position. This data transfer takes 5 $\mu$ s after the supply has reached the POR trigger level.

## Programming the Device

Write commands (see [Table 6](#)) require 16 clock cycles (see [Figure 22 on page 13](#)) to clock in the command and data.

Copy and Read commands (see [Table 6](#)) can use 8 clock cycles to clock in the command (see [Figure 21 on page 13](#)) or 16 clock cycles. At 16 clock cycle commands the 8 data bits (D7:D0) are insignificant.

Table 6. Command/Data Word Format

Command	1	2	3	4	5	6	7	8	9	10	11	12	13	14	15	16
	C7	C6	C5	C4	C3	C2	C1	C0	D7	D6	D5	D4	D3	D2	D1	D0
Write Wiper Register A	0	0	0	0	0	0	0	1	D7	D6	D5	D4	D3	D2	D1	D0
Write Wiper Register B	0	0	0	0	0	0	1	0	D7	D6	D5	D4	D3	D2	D1	D0
Write both Wiper Registers	0	0	0	0	0	0	1	1	D7	D6	D5	D4	D3	D2	D1	D0
Write to Non-Volatile Register A	0	0	0	1	0	0	0	1	D7	D6	D5	D4	D3	D2	D1	D0
Write to Non-Volatile Register B	0	0	0	1	0	0	1	0	D7	D6	D5	D4	D3	D2	D1	D0
Write to both Non-Volatile Registers	0	0	0	1	0	0	1	1	D7	D6	D5	D4	D3	D2	D1	D0
Copy Wiper Register A to Non-Volatile Register	0	0	1	0	0	0	0	1	-	-	-	-	-	-	-	-
Copy Wiper Register B to Non-Volatile Register	0	0	1	0	0	0	1	0	-	-	-	-	-	-	-	-
Copy Both Wiper Registers to Non-Volatile Registers	0	0	1	0	0	0	1	1	-	-	-	-	-	-	-	-
Copy Non-Volatile Register A to Wiper Register	0	0	1	1	0	0	0	1	-	-	-	-	-	-	-	-
Copy Non-Volatile Register B to Wiper Register	0	0	1	1	0	0	1	0	-	-	-	-	-	-	-	-
Copy Both Non-Volatile Registers to Wiper Registers	0	0	1	1	0	0	1	1	-	-	-	-	-	-	-	-
Read Wiper A	0	1	1	0	1	0	0	1	-	-	-	-	-	-	-	-
Read Wiper B	0	1	1	0	1	0	1	0	-	-	-	-	-	-	-	-
Read Non-Volatile Register A	0	0	1	0	1	0	0	1	-	-	-	-	-	-	-	-
Read Non-Volatile Register B	0	0	1	0	1	0	1	0	-	-	-	-	-	-	-	-

## Commands

### Write Wiper Register

This is a 16-bit command (see Figure 22 on page 13). The first byte represents the command word starting with the MSB bit of the command, the second byte represents the data written to the wiper register (starting with the MSB). Data 0000 0000 the wiper moves the closest position to LOW, with data 1111 1111 the wiper moves to the closest position to HIGH. The wiper registers can be written independently in two write cycles with different data or in one write cycle with the same data.

**Note:** At power-up the wiper position stored in the non-volatile memory are automatically loaded into the wiper register, the wiper moves to the related position.

### Write to Non-Volatile Register

This is a 16-bit command (see Figure 22 on page 13). The first byte represents the command word starting with the MSB bit of the command, the second byte represents the data written to the non-volatile memory. The wiper position is not changed by this command, since the wiper register is not affected. The non-volatile registers can be written independently in two write cycles with different data or in one write cycle with the same data.

There is a write non-volatile register time defined in the timing specification, which is required for storing the data in the non-volatile register. The READY pin indicates the write time with an active-low signal. During this time the device must not be powered down, otherwise the data stored in the non-volatile register is corrupted.

### Copy Wiper Register to Non-Volatile Register

This command can be implemented as an 8- or 16-bit command. The data stored in the wiper register are transferred to the non-volatile memory, to keep the data during power-down. There is no automatic trigger of this command during power-down of the device. This command must be triggered before powering down the device.

There is a write non-volatile register time defined in the timing specification, which is required for storing the data in the non-volatile register. During this time the device must not be powered down, otherwise the data stored in the non-volatile register is corrupted.

### Copy Non-Volatile Register to Wiper Register

This command can be implemented as an 8- or 16-bit command. The data stored in the non-volatile register are transferred to the wiper register, the wiper register moves to the stored position. This command is automatically executed during power up of the system.

### Read Non-Volatile Register

The AS1507 features the capability to read the data from the non-volatile register via the SPI interface (see Figure 23 on page 13). This command can be implemented as an 8- or 16-bit command. The SDIO pin is a bi-directional pin. During the CSN low phase of the sequence the SDIO pin is used as input pin to set the command byte. After CSN rising edge the pin SDIO is set as output pin, the data stored in the non-volatile register are read serially, MSB first.

The data propagation starts at the second rising edge of SCLK after the rising edge of CSN. CSN must be high during the read operation. With the next falling edge of CSN the SDIO pin is set to an input pin again.

### Read Wiper Register

The AS1507 features the capability to read the data from the wiper register via the SPI interface (see Figure 23 on page 13). This command can be implemented as an 8- or 16-bit command. The SDIO pin is a bi-directional pin. During the CSN low phase of the sequence, the SDIO pin is used as input pin to set the command byte. After CSN rising edge the pin SDIO is set as output pin, the data stored in the wiper register are read serially, MSB first. The wiper position is unchanged.

The data propagation starts at the second rising edge of SCLK after the rising edge of CSN. CSN must be high during the read operation. With the next falling edge of CSN the SDIO pin is set to an input pin again.

### Mute Command

When a high signal is applied on the MUTE pin both wiper positions are set to zero permanently. While in mute operation SPI commands to wiper registers are not executed. Data stored in non-volatile registers are not affected by the mute command. The MUTE pin includes a pull-down resistor. If a mute function is not required the pin can be left unconnected.

Figure 21. 8-Bit Command Word

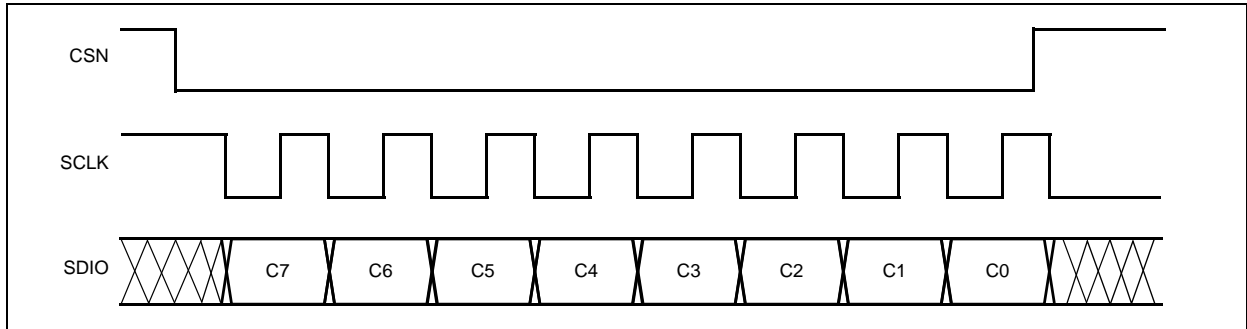

Figure 22. 16-Bit Command/Data Word

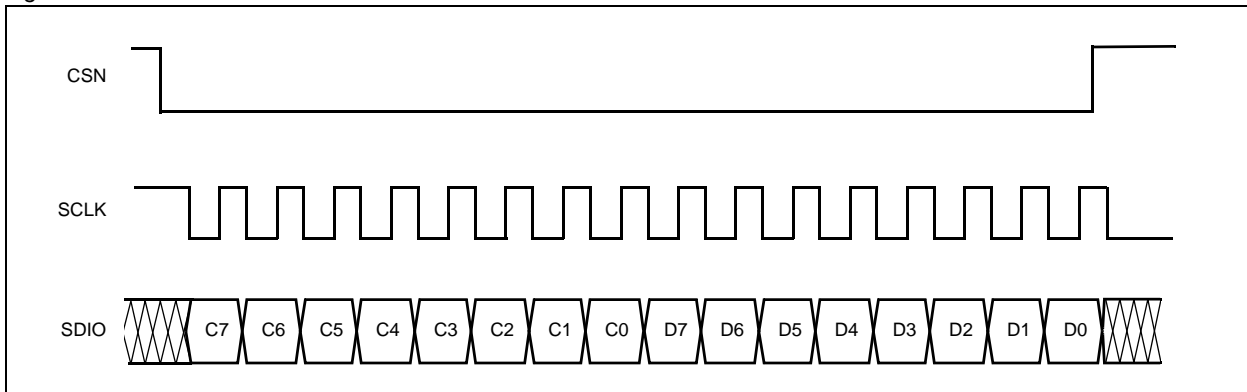

Figure 23. 16-Bit Read Command

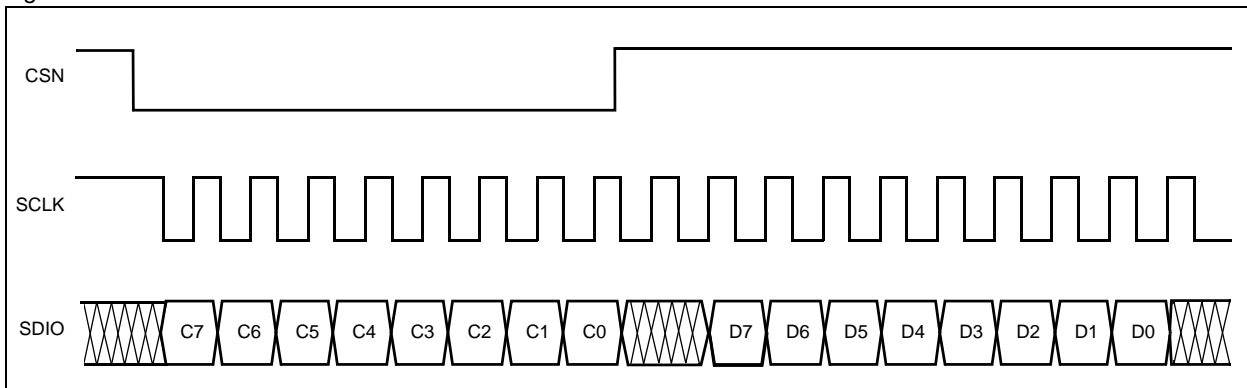
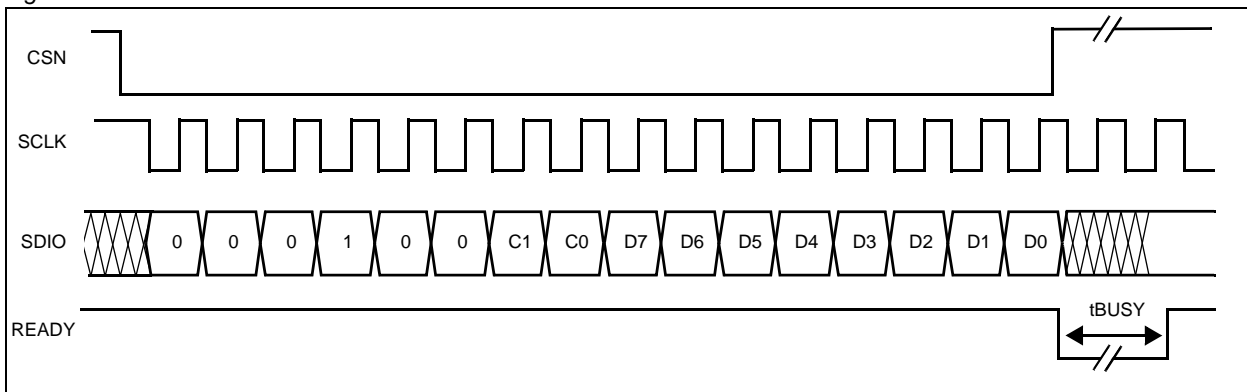

Figure 24. 16-Bit EEPROM Write Command



## 9 Application Information

The AS1507 is intended for circuits requiring digitally controlled adjustable resistance, such as LCD contrast control (where voltage biasing adjusts the display contrast), or programmable filters with adjustable gain and/or cutoff frequency.

### Programmable Filter

Figure 25 shows the configuration for a 1st-order programmable filter.

The DC gain of the filter is adjusted by R2 and can be calculated as:

$$G = 1 + (R1/R2) \quad (EQ 1)$$

The cutoff frequency (fc) is adjusted by R3, and can be calculated as:

$$f_c = 1/(2\pi \times R3 \times C) \quad (EQ 2)$$

Figure 25. Programmable Filter Circuit

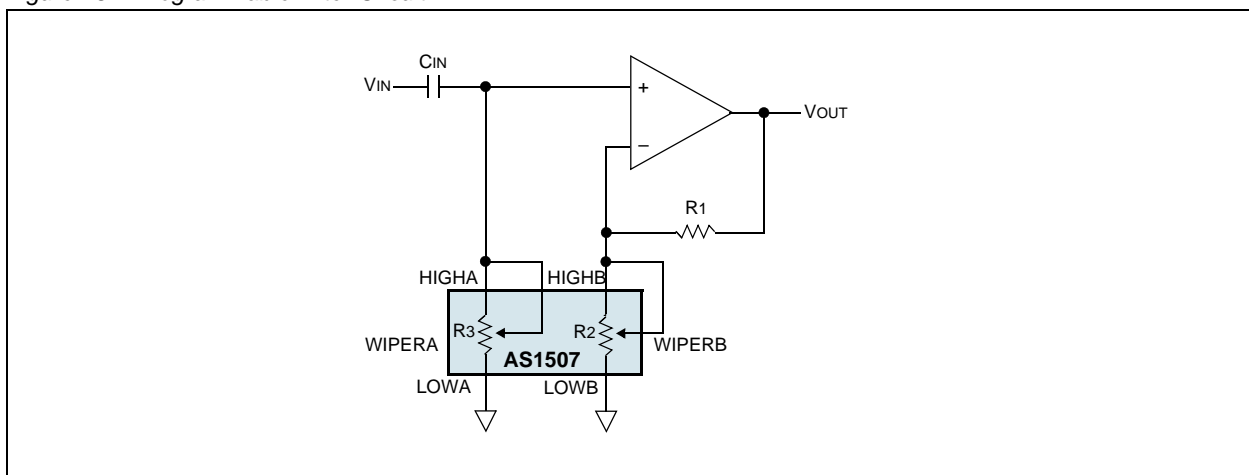

### Offset Voltage and Gain Adjustment

Connect one potentiometer of the AS1507 to an op amp to nullify the offset voltage over the operating temperature range. Use the second potentiometer in the feedback path to adjust the gain of the op amp (Figure 26).

Figure 26. Offset Voltage and Gain Adjustment Circuit

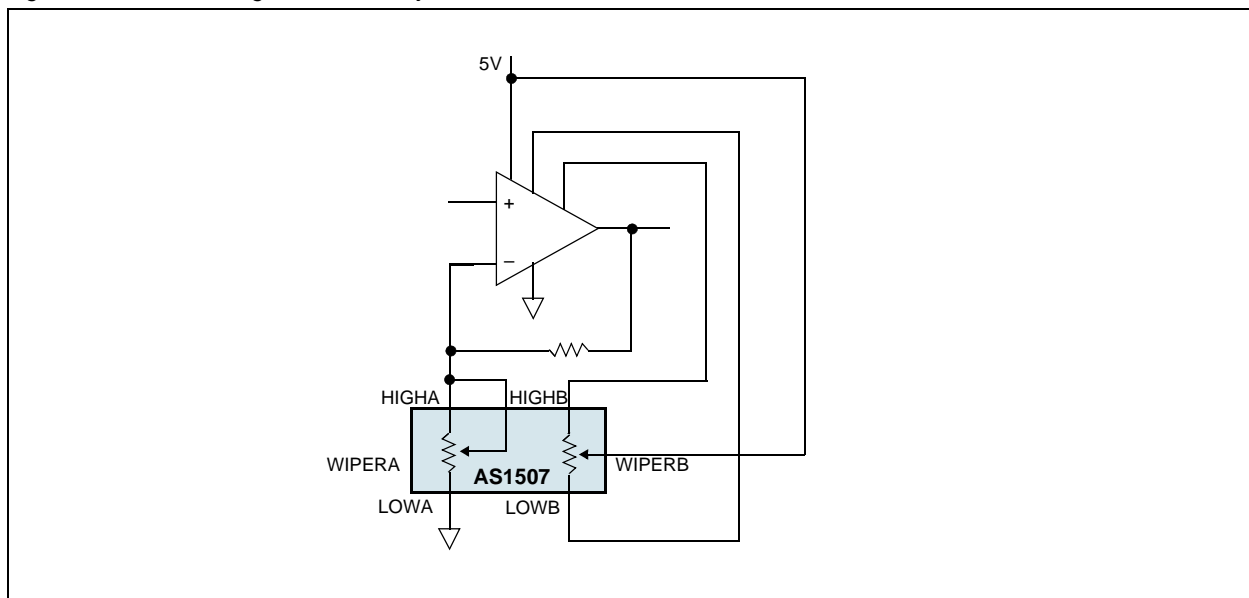

## Positive LCD Bias Control

The device can be used in applications where a voltage-divider or variable resistor is used to make an adjustable, positive LCD-bias voltage, such as for the AS1120 LCD Driver. The op amp provides buffering and gain to the resistor-divider network made by the potentiometer (Figure 27) or to a fixed resistor and a variable resistor (Figure 28).

Figure 27. Positive LCD Bias Control using a Voltage Divider

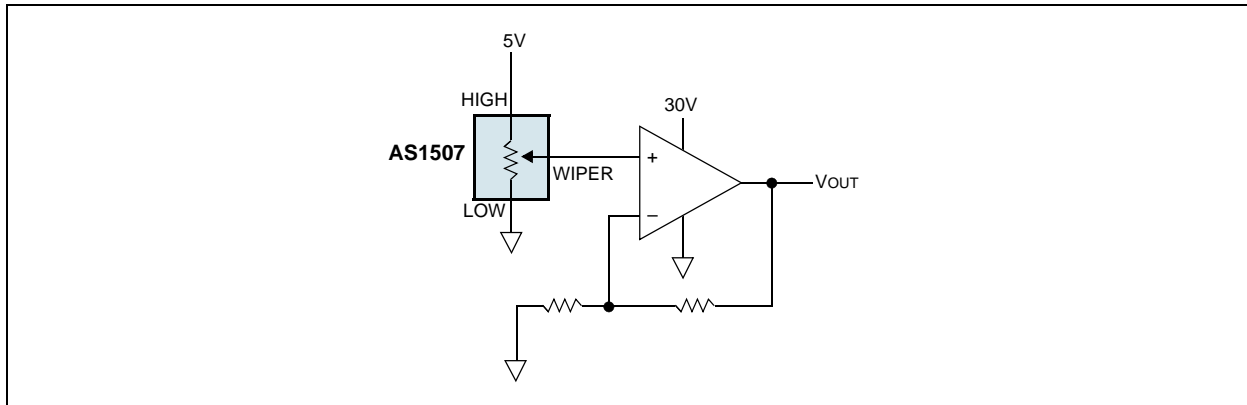
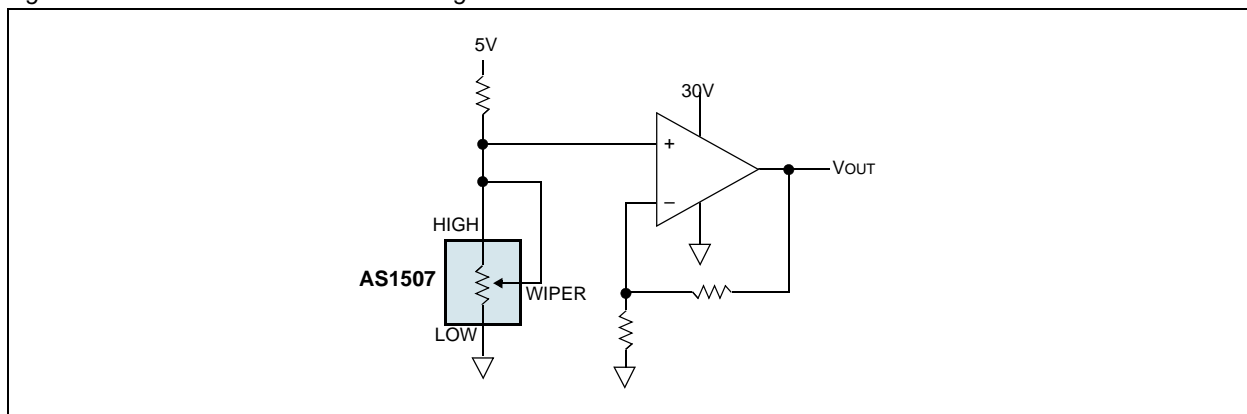

Figure 28. Positive LCD Bias Control using a Variable Resistor



## Adjustable Voltage Reference

Figure 29 shows the device used as the feedback resistor in an adjustable voltage-reference application. Output voltages of external voltage references, supervisory reset thresholds, or LED brightness control can be independently adjusted by changing the wiper position of the AS1507.

Figure 29. Adjustable Voltage Reference Circuit –  $V_{OUT} = 1.23V(50k\Omega/R_2(k\Omega))$

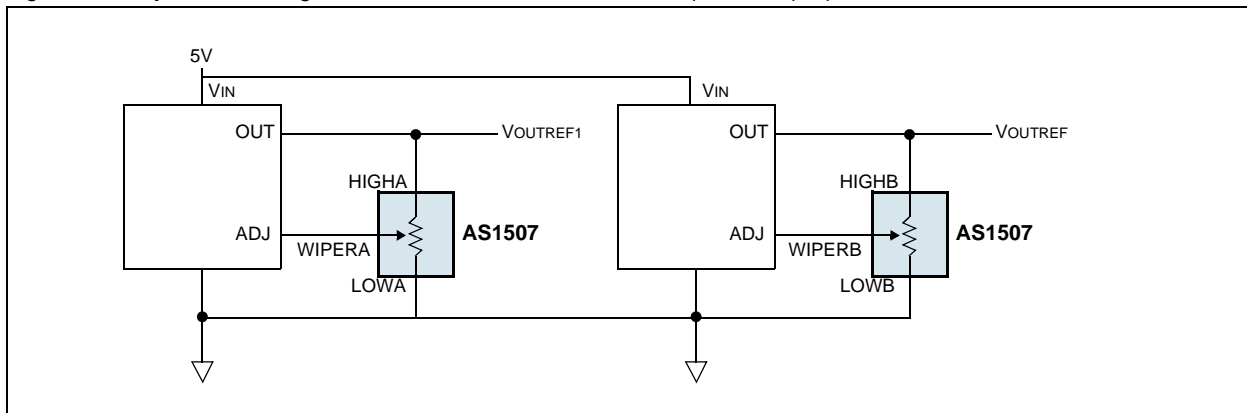



## 11 Ordering Information

The device is available as the standard products shown in [Table 7](#).

Table 7. Ordering Information

Ordering Code	Marking	Description	End-to-End Resistance	Delivery Form	Package
AS1507-BTDT-10	ASPF	Dual 256-Tap Digital Potentiometer with SPI Interface and High Endurance EEPROM	10k $\Omega$	Tape and Reel	TQFN 3x3mm 16-pin
AS1507-BTDT-50	ASPE	Dual 256-Tap Digital Potentiometer with SPI Interface and High Endurance EEPROM	50k $\Omega$	Tape and Reel	TQFN 3x3mm 16-pin
AS1507-BTDT-100	ASPD	Dual 256-Tap Digital Potentiometer with SPI Interface and High Endurance EEPROM	100k $\Omega$	Tape and Reel	TQFN 3x3mm 16-pin

**Note:** All products are RoHS compliant.

Buy our products or get free samples online at ICdirect: <http://www.austriamicrosystems.com/ICdirect>

Technical Support is found at <http://www.austriamicrosystems.com/Technical-Support>

For further information and requests, please contact us <mailto:sales@austriamicrosystems.com> or find your local distributor at <http://www.austriamicrosystems.com/distributor>

## Copyrights

Copyright © 1997-2010, austriamicrosystems AG, Tobelbaderstrasse 30, 8141 Unterpremstaetten, Austria-Europe. Trademarks Registered ®. All rights reserved. The material herein may not be reproduced, adapted, merged, translated, stored, or used without the prior written consent of the copyright owner.

All products and companies mentioned are trademarks or registered trademarks of their respective companies.

## Disclaimer

Devices sold by austriamicrosystems AG are covered by the warranty and patent indemnification provisions appearing in its Term of Sale. austriamicrosystems AG makes no warranty, express, statutory, implied, or by description regarding the information set forth herein or regarding the freedom of the described devices from patent infringement. austriamicrosystems AG reserves the right to change specifications and prices at any time and without notice. Therefore, prior to designing this product into a system, it is necessary to check with austriamicrosystems AG for current information. This product is intended for use in normal commercial applications. Applications requiring extended temperature range, unusual environmental requirements, or high reliability applications, such as military, medical life-support or life-sustaining equipment are specifically not recommended without additional processing by austriamicrosystems AG for each application. For shipments of less than 100 parts the manufacturing flow might show deviations from the standard production flow, such as test flow or test location.

The information furnished here by austriamicrosystems AG is believed to be correct and accurate. However, austriamicrosystems AG shall not be liable to recipient or any third party for any damages, including but not limited to personal injury, property damage, loss of profits, loss of use, interruption of business or indirect, special, incidental or consequential damages, of any kind, in connection with or arising out of the furnishing, performance or use of the technical data herein. No obligation or liability to recipient or any third party shall arise or flow out of austriamicrosystems AG rendering of technical or other services.



## Contact Information

### Headquarters

austriamicrosystems AG  
Tobelbaderstrasse 30  
A-8141 Unterpremstaetten, Austria

Tel: +43 (0) 3136 500 0  
Fax: +43 (0) 3136 525 01

For Sales Offices, Distributors and Representatives, please visit:

<http://www.austriamicrosystems.com/contact>

## Looking for pricing, stock, or lifecycle information?

Click below to explore more details on WIN SOURCE:

 [View AS1507-BTDT-100](#) on WIN SOURCE

 [ams](#) Information

## Optimize Your Supply Chain with WIN SOURCE Solutions

-  Global Sourcing Solution
-  Obsolete Management
-  Cost Control Management
-  Shortage Management
-  Alternative Solution
-  Excess Inventory Management