



THE DATASHEET OF AS1135





Datasheet

AS1135

13W/30W IEEE 802.3af/at

**PoE Powered Device with Integrated
DC-DC Controller**

Version 1.5

January 2012

TABLE OF CONTENTS

TABLE OF CONTENTS2

FIGURES3

TABLES3

GENERAL DESCRIPTION4

FEATURES4

TYPICAL APPLICATIONS4

PIN-OUT DIAGRAM5

PIN ASSIGNMENTS5

ABSOLUTE MAXIMUM RATINGS6

NORMAL OPERATING CONDITIONS6

ELECTRICAL CHARACTERISTICS6

PACKAGE THERMAL CHARACTERISTICS9

TYPICAL PERFORMANCE CHARACTERISTICS9

FUNCTIONAL DESCRIPTION..... 17

 Overview of PoE 17

 AS1135 POE Design 17

 Power Feed Alternatives for 10/100/1000 Ethernet Systems 17

AS1135 OVERVIEW 19

 Rectification and Protection 20

 PD Controller 20

 Modes of Operation 20

 PoE Power-On Startup Waveform 22

 Maintain Power Signature (MPS) 23

 PD Controller Power and Thermal Protection 23

 Short-Circuit Protection 23

 ATDET pin 24

 Local Power Mode (LVMODE) 24

 DC-DC Controller 25

 DC-DC Converter Topologies 25

APPLICATION CIRCUITS 26

THERMAL DE-RATING AND BOARD LAYOUT CONSIDERATIONS 27

PHYSICAL DIMENSIONS 28

CONTACT INFORMATION 29

IMPORTANT NOTICES 29

 Legal Notice 29

 Reference Design Policy 29

 Life Support Policy 29

 Substance Compliance 29

Status:	Final Information
Revision:	Version 1.5
Release Date:	January 2012
Documentation Feedback:	http://www.akrossilicon.com/content/as1135?q=content/document-feedback
Advance Information: Document contains design specifications for initial product development. Preliminary Information: Document contains preliminary data and will be revised at a later date. Final Information: Document contains specifications on a product that is in final release.	

FIGURES

Figure 1 - Typical Application of a PoE PD (Flyback Converter)	4
Figure 2 - Pin-out Diagram	5
Figure 3 - Feedback Error Amplifier V_{REF} vs.	9
Figure 4 - VDD5 vs. Junction Temperature	9
Figure 5 - VDD5 vs. V_{IN}	10
Figure 6 - DC Current Limit vs. Junction Temperature.....	10
Figure 7 - $R_{DS(ON)}$ vs. Temperature @ 350mA, 48V	10
Figure 8 - OSC vs. Temperature	10
Figure 9 - 48V V_{DD} Load Regulation vs. Temperature	11
Figure 10 - Inrush Current vs. Temperature	11
Figure 11 - 48V V_{DD} NDRV vs. Temperature	11
Figure 12 - Comp Source vs. Temperature	11
Figure 13 - Comp Sink vs. Temperature	12
Figure 14 - Example of VDD48I / VDD48O / Converter Output	13
Figure 15 - PI Input Voltage and Current / ATDET	13
Figure 16 - 3.3V 30W DC-DC Efficiency vs. Load.....	14
Figure 17 - 3.3V 30W End-End Efficiency vs. Load	14
Figure 18 - 3.3V 30W Load Regulation	14
Figure 19 - 3.3V 30W Line Regulation	14
Figure 20 - 5V 30W DC-DC Efficiency vs. Load.....	15
Figure 21 - 5V 30W End-End Efficiency vs. Load	15
Figure 22 - 5V 30W Load Regulation	15
Figure 23 - 5V 30W Line Regulation	15
Figure 24 - 12V 30W DC-DC Efficiency vs. Load.....	16
Figure 25 - 12V 30W End-End Efficiency vs. Load	16
Figure 26 - 12V 30W Load Regulation	16
Figure 27 - 12V 30W Line Regulation	16
Figure 28 - IEEE® Std. 802.3at-2009 Power Feeding Schemes for 10/100 Systems	18
Figure 29 - AS1135 Top-Level Block Diagram	19
Figure 30 - 802.3at Typical Power-On Waveform	22
Figure 31 - Short-Circuit Protection	23
Figure 32 - LVMODE Implementation	24
Figure 33 - PoE PD Controller with High-Efficiency Isolated Synchronous Flyback DC-DC Converter	26
Figure 34 - PoE PD Controller with Non-Isolated BUCK DC-DC converter	26
Figure 35 - AS1135 PCB Footprint (Top View)	27
Figure 36 - Physical Dimensions	28

TABLES

Table 1 - Pin Assignments.....	5
Table 2 - Absolute Maximum Ratings.....	6
Table 3 - Normal Operating Conditions	6
Table 4 - Electrical Characteristics	6
Table 5 - Package Thermal Characteristics	9
Table 6 - PoE Requirements	17
Table 7 - Classification Settings	21
Table 8 - ATDET Truth Table	24
Table 9 - LVMODE Configuration.....	25
Table 10 - PWM Switching Frequency Selection	25

GENERAL DESCRIPTION

The AS1135 is a single-chip, highly integrated CMOS solution for Power over Ethernet (PoE) Powered Devices requiring input power of up to 30Watts. Applications include Voice over IP (VoIP) Phones, Wireless LAN Access Point, Security Cameras, WiMax Terminals, Point-of-Sales Terminals, RFID Readers, Thin Clients and Notebook computers.

The AS1135 integrates input surge protection, a PD controller and a low-emission DC-DC controller. The AS1135 implements all of the physical layer Powered Device (PD) functionality, as required by IEEE® 802.3af-2005 and IEEE® 802.3at-2009 standards. This includes 2-event classification, Type 2 PSE detection indicator (ATDET), PD detection, under-voltage lock out (UVLO), and Hot-Swap FET integration.

The AS1135 has been architected to address both EM emission concerns and surge/over-voltage protection in PoE applications. The chip implements many design features that minimize transmission of system common-mode noise onto the Unshielded Twisted Pair (UTP). On-chip integration of surge protection provides faster response to surge events and limits stray surge current from passing through sensitive circuits, such as the Ethernet PHY. The device is designed to provide safe, low-impedance discharge paths directly to the earth ground, resulting in superior reliability and circuit protection.

By using high-volume standard CMOS technology, Akros enables its customers to implement higher-performance PoE devices with low cost and a small footprint.

FEATURES

The AS1135 is fully integrated and architected at a system level to provide the following features and compliance:

- Full support of both IEEE® Std. 802.3af-2005 and IEEE® Std. 802.3at-2009 power requirements
- “2-Event” classification for 802.3at higher power PDs
- Robust Type 2 PSE detector with proprietary digital filtering for line noise to eliminate false positives
- IEC 61000-4-2/3/4/5/6 requirements for EMC Compliance
- Integrated Surge Protection for 15kV/8kV System level ESD Compliance
- Integrated DC-DC controller for exceptional EMI performance
- Programmable DC current limit up to 720mA for 30W applications
- Seamless support for local power, down to 9.5V
- Implemented in robust 100V automotive process
- Low Rds-on Hot-Swap FET (typical 0.8Ω)
- Over temperature protection
- Industrial temperature range, -40° to +85°C
- 5x5 mm, 20 lead QFN Package, RoHS compliant

TYPICAL APPLICATIONS

- Pan, tilt and zoom (PTZ), security and web cameras
- Voice over IP (VoIP) phones
- Wireless LAN access points, WiMax terminals
- Point-of-sale (PoS) terminals, RFID terminals
- Thin clients and notebook computers
- Fiber-to-the-home (FTTH) terminal

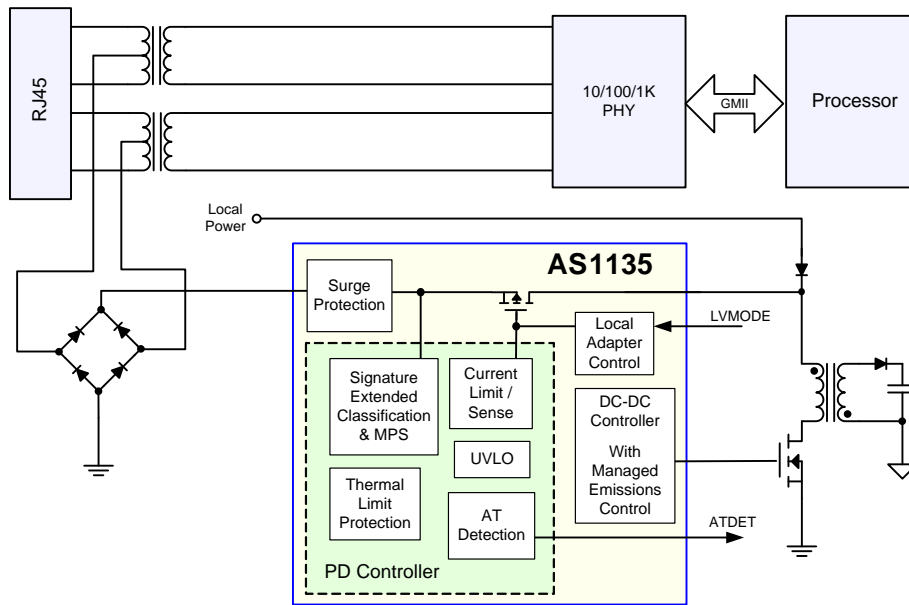

Figure 1 - Typical Application of a PoE PD (Flyback Converter)

PIN-OUT DIAGRAM

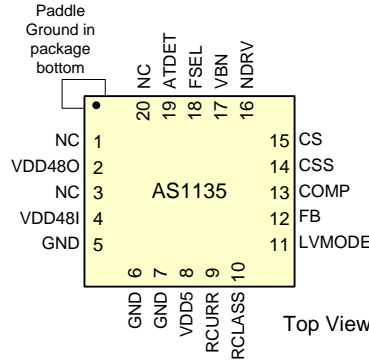

Figure 2 - Pin-out Diagram

PIN ASSIGNMENTS

Table 1 - Pin Assignments			
Pin	I/O	Name	Description
1	-	NC	No Connect
2	P	VDD48O	Switched 48V supply output
3	-	NC	No Connect
4	P	VDD48I	48 V positive bus pin, fed by the output of the external diode bridge. This bus requires the connection of a detection signature capacitor and resistor. Refer to Detection Mode section.
5	A	GND	Must be connected to paddle ground (GND)
6	A	GND	Must be connected to paddle ground (GND)
7	A	GND	Must be connected to paddle ground (GND)
8	O	VDD5	Internal 5 volts bus decoupling point
9	A	RCURR	Current limit pin. Connection to paddle ground sets the current limit to ILIM-AF (for 13W applications). Open circuit sets the current limit to ILIM-AT (for 30W applications).
10	A	RCLASS	Classification resistor connection
11	A	LVMODE	Local Voltage Mode. When pulled high, LVMODE opens the internal FET switch and keeps the DC-DC controller active. This is a current-mode input pin. It should be pulled to GND when not in used.
12	A	FB	DC-DC Controller feedback point
13	A	COMP	DC-DC Controller error amplifier compensation network connection
14	A	CSS	DC-DC Controller soft-start capacitor connection point
15	A	CS	DC-DC Controller peak-current sense input (low side)
16	O	NDRV	DC-DC Controller N-MOSFET gate drive
17	O	VBN	DC-DC Controller low-side supply decoupling
18	I	FSEL	Frequency Select. This pin sets the switching frequency of the DC-DC converter.
19	O	ATDET	IEEE® 802.3at-2009 PSE detect. High level output indicates availability of higher system power, either via connection to a Type 2 PSE, or via a local power supply.
20	-	NC	No Connect
Paddle	P	GND	Local analog ground. This is the negative output from the external diode bridge and is not isolated from the line input.

Key: I = Input O = Output A = Analog signal P = Power

ABSOLUTE MAXIMUM RATINGS

Table 2 - Absolute Maximum Ratings		
Description	Max Value ¹	Units
High-voltage pins (4—VDD48I; 2—VDD48O) under Transient conditions ⁴	100	Volts
High-voltage pins (4—VDD48I; 2—VDD48O) Steady-state with internal Surge Clamp	60	Volts
Low-voltage pins (8—VDD5; 9—RCURR; 10—RCLASS; 11—LVMODE; 12—FB; 13—COMP; 14—CSS; 15—CS; 16—NDRV; 17—VBN; 18—FSEL; 19—ATDET)	6	Volts
ESD Ratings		
Human body model ²	2	kV
ESD charged device model	500	V
ESD machine model	200	V
System level (contact/air) at RJ-45 ³	8/15	kV
Temperature		
Storage temperature	165	°C
Junction temperature	150	°C

¹ Absolute maximum ratings are limits beyond which damage to the device may occur.

² The human body model is as described in JESD22-A114.

³ System ESD testing done per IEC61000-4-2.

⁴ Transient conditions like system startup and other noise conditions. Device must not be exposed to sustained over-voltage condition at this level. See section on Rectification and Protection for further details on Integrated Surge Protection.

NORMAL OPERATING CONDITIONS

Table 3 - Normal Operating Conditions			
Unless otherwise noted, specifications are for $V_{in} = 48V$.			
Description	Min	Typical ¹	Max
V_{IN-AF} (Type 1 PD)	37V	48V	57V
V_{IN-AT} (Type 2 PD)	42.5V	48V	57V
Operating temperature range,	-40°C		+85°C

¹ Typical specification; not 100% tested. Performance guaranteed by design and/or other correlation methods.

ELECTRICAL CHARACTERISTICS

Table 4 - Electrical Characteristics					
Unless otherwise noted, specifications are for $T_a = -40^{\circ}C$ to $+85^{\circ}C$ and $V_{IN} = 48V$ (at RJ45 input).					
Description	Min	Typical ¹	Max	Units	Comments ²
PD (all PD voltage limits specified at the RJ45 interface)					
Inrush current limit (af) – Type 1 PD	50	150	200	mA	For $V_{DD48O} \leq 16V$ during startup
Inrush current limit (at) – Type 2 PD	100	295	350	mA	For $V_{DD48O} \leq 16V$ during startup

Table 4 - Electrical Characteristics

Unless otherwise noted, specifications are for Ta = -40°C to +85°C and VIN = 48V (at RJ45 input).

Description	Min	Typical ¹	Max	Units	Comments ²	
Operating current – Type 1			350	mA	Pin 9 (RCURR) pulled to GND; device configured for 13W operation	
Operating current – Type 2			720	mA	Pin 9 (RCURR) left open; device configured for 30W operation	
PoE current limit – Type 1 (ILIM-AF)	350	400	500	mA	Pin 9 (RCURR) pulled to GND; device configured for 13W operation	
PoE Current limit – Type 2 (ILIM-AT)	720	800	925	mA	Pin 9 (RCURR) left open; device configured for 30W operation	
Switch on resistance, R _{DS-ON}		0.8	1	Ω	measured at 350mA input	
Min Detection Signature voltage			2.7	V		
Max Detection Signature voltage	10.1	12.5	13	V		
Classification lower threshold	11	12.5	14.5	V	During Classification, the AS1135 sinks current as defined Table 7.	
Classification upper threshold	20.5	22	24	V		
Min Mark Event voltage			6.9	V		
Max Mark Event voltage	10	12.5	13	V		
Mark Event current	0.25		4	mA	When the input voltage is less than V _{MARK_TH} Min (IEEE® 802.3at-2009) during the Classification signature, a Type 2 PD must draw Mark Event current.	
Classification-Mark hysteresis		1		V		
Classification reset voltage	2.81		6.9	V		
ATDET high (V _{OH})	4.7	4.9	5.1	V	Under 2mA output	
ATDET low (V _{OL})	0.0	0.02	0.1	V	2ma input current	
UVLO threshold, V _{IN_RISING}	37	38	42	V		
UVLO threshold, V _{IN_FALLING}	30	32	34	V		
DC-DC Controller						
F _{OSC} (SMPS) switching frequency	80	100	120	kHz	Rosc=178kΩ	DC-DC Controller operating frequency, selected by using Rosc (1%) resistor on FSEL pin
	200	225	250		Rosc=100kΩ	
	315	350	385		Rosc=53.6kΩ	
	450	500	550		Rosc=36.8kΩ	
F _{OSC} temperature coefficient		0.12		%/C		
NDRV R _{OUT}		1.2	3	Ω	Output drive resistance	
NDRV voltage		4.7			NDRV voltage follows VBN power supply voltage	
Gate drive dynamic response		2.2		nS	10% - 90% with C _{LOAD} = 1 nF	
NDRV T _R , T _F		2		nS		
Max. NDRV duty cycle		80		%	Measured at 350kHz	
Min. NDRV duty cycle		6	10	%	Measured at 350kHz	

Table 4 - Electrical Characteristics					
Unless otherwise noted, specifications are for Ta = -40°C to +85°C and VIN = 48V (at RJ45 input).					
Description	Min	Typical ¹	Max	Units	Comments ²
VBN		4.7		V	Internal supply voltage; sets V _{OH} of NDRV.
Error amplifier reference voltage	1.45	1.5	1.55	V	Compared to input of the FB pin
V _{PK} , peak current sense threshold voltage at CS	500	600	700	mV	I _{PEAK} =V _{PK} /R _{SENSE}
Soft start ramp time		2		ms	Conditions: CSS=100nF
COMP source current		80		μA	FB = 0V, COMP=0V
COMP sink current		80		μA	FB = 5V, COMP=5V
Open loop voltage gain (Error amplifier)		80		dB	
Small signal unity-gain bandwidth		5		MHz	COMP connected to FB.
FB leakage (source or sink)		1		μA	
Local Power Mode					
LVMODE threshold low (I _{IL})			20	μA	
LVMODE threshold high (I _{IH})	60			μA	
Local power operating voltage range	9.5		57	V	Local power voltage is specified between VDD480 and GND, using LVMODE feature. Note that power transformer must be capable of handling that full voltage range
Thermal Protection					
Thermal shutdown temperature		165		°C	Above this Temp., the AS1135 is disabled.
Thermal shutdown hysteresis		40		°C	Temperature change required to restore full operation after thermal shutdown
Current reduction temperature threshold		145		°C	Temperature at which thermal current reduction is applied
Thermal current reduction		50		%	
Thermal current reduction hysteresis		20		°C	Temperature change required to restore full operation after thermal current reduction
Power Dissipation					
Power dissipation, Type 1, P _{Diss}		0.3	0.5	W	Measured at 13W input
Power dissipation, Type 2, P _{Diss}		0.8	1.3	W	Measured at 30W input
Max. on-die operating temperature			140	°C	Maximum recommended operating temperature for normal operation

¹ Typical specifications are not 100% tested. Performance guaranteed by design and/or other correlation methods.

² All measurements made at the Network Interface assuming a 1.2V drop across a diode bridge.

PACKAGE THERMAL CHARACTERISTICS

Table 5 - Package Thermal Characteristics					
	Min	Typical ¹	Max	Units	Comments
Thermal Resistance, Junction to Ambient, θ_{JA}		31		°C/W	20 lead QFN package
Thermal Resistance, Junction to Case, θ_{JC}		3.4		°C/W	20 lead QFN package

¹ Typical specification are not 100% tested. Performance guaranteed by design and/or other correlation methods.

TYPICAL PERFORMANCE CHARACTERISTICS

Figure 3 - Feedback Error Amplifier V_{REF} vs. Junction Temperature

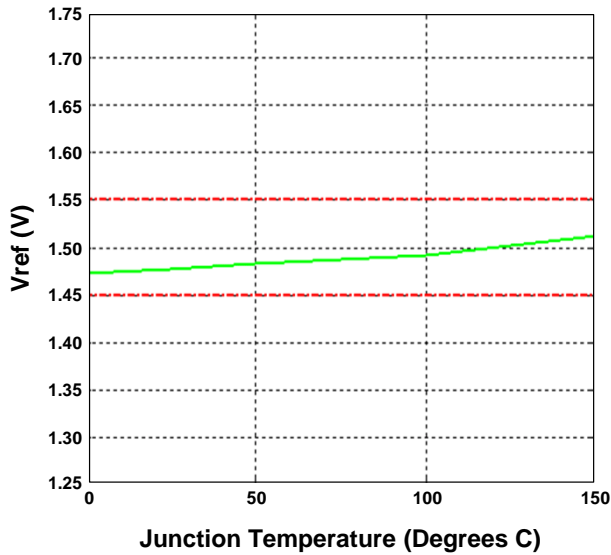

Figure 4 - VDD5 vs. Junction Temperature

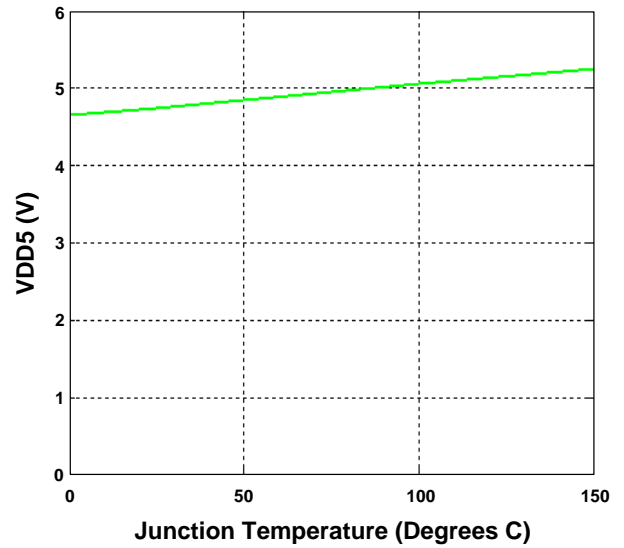

Figure 5 - VDD5 vs. V_{IN}

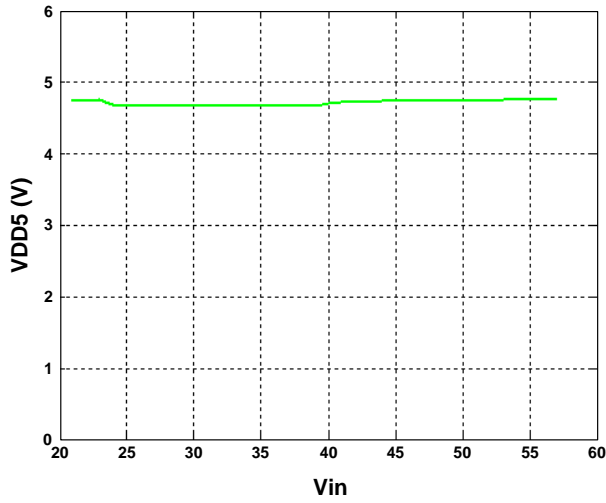

Figure 7 - $R_{DS(on)}$ vs. Temperature @ 350mA, 48V

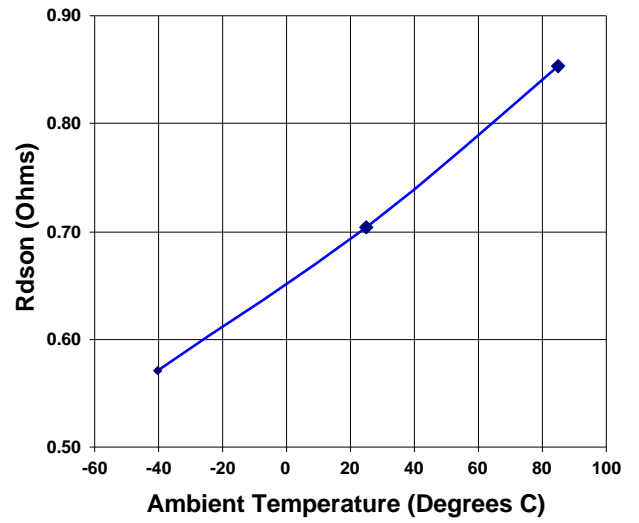

Figure 6 - DC Current Limit vs. Junction Temperature

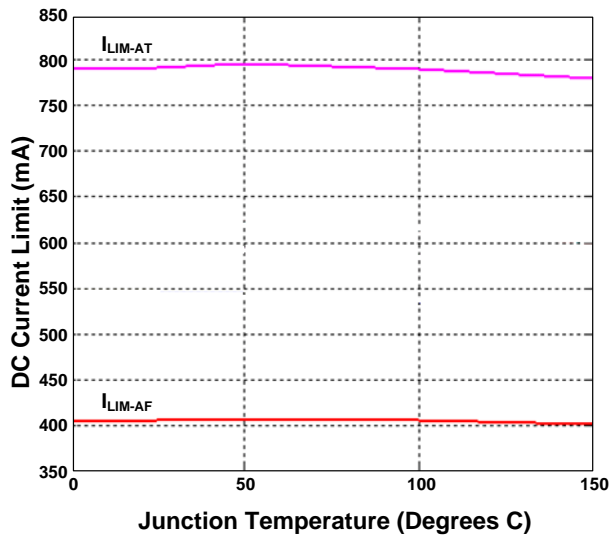

Figure 8 - OSC vs. Temperature

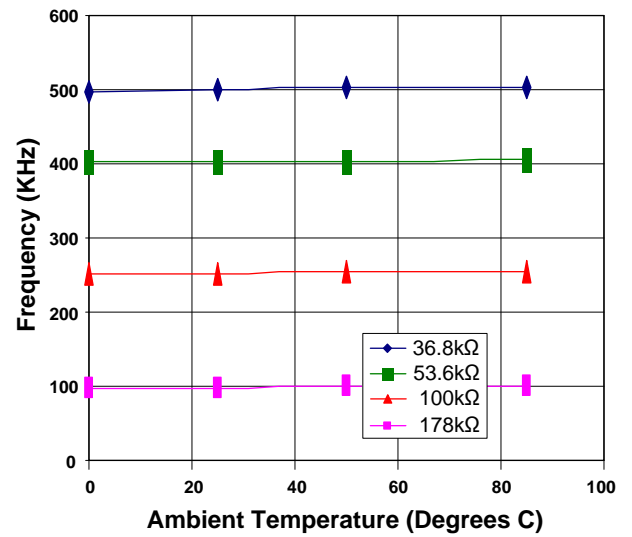

Figure 9 - 48V V_{DD} Load Regulation vs. Temperature

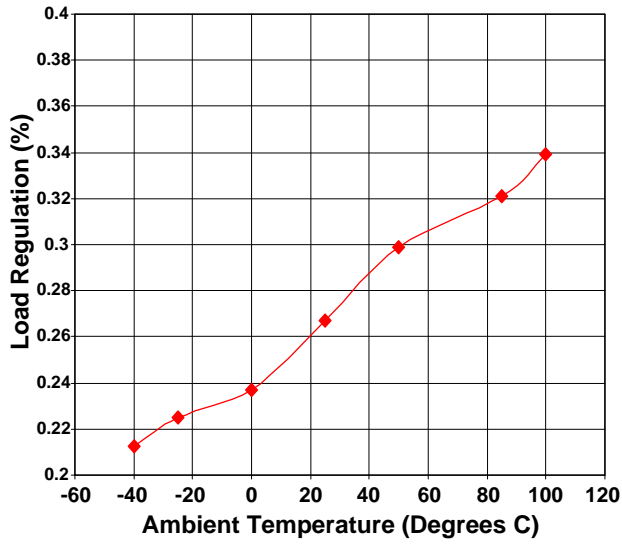

Figure 11 - 48V V_{DD} NDRV vs. Temperature

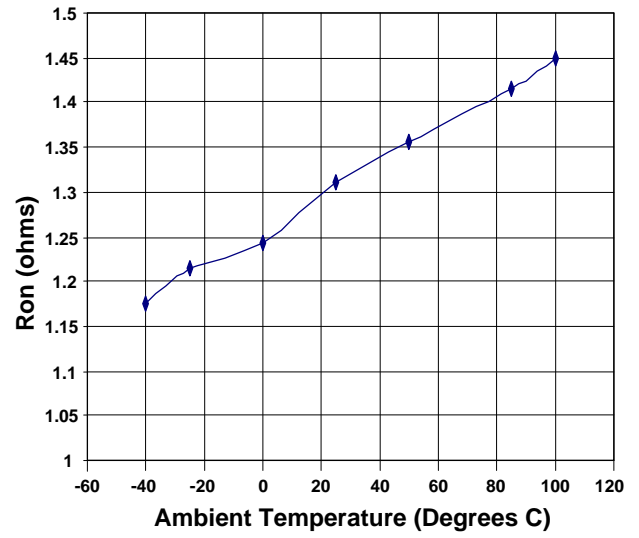

Figure 10 - Inrush Current vs. Temperature

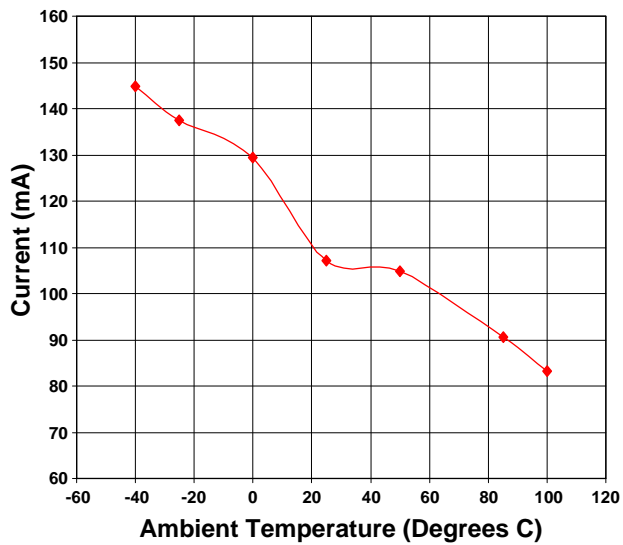

Figure 12 - Comp Source vs. Temperature

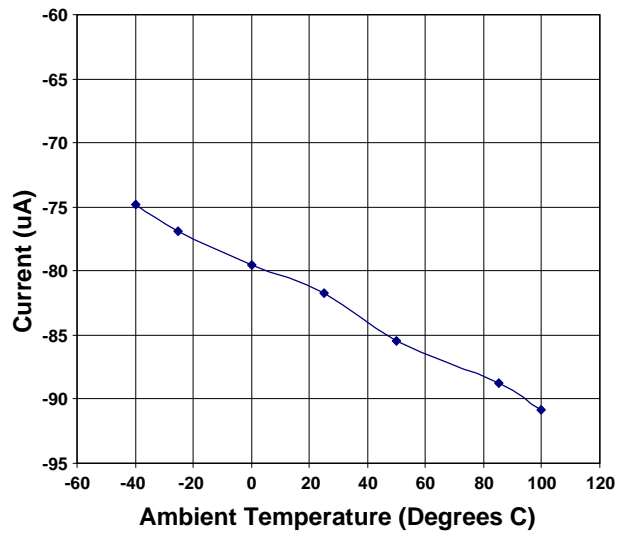

Figure 13 - Comp Sink vs. Temperature

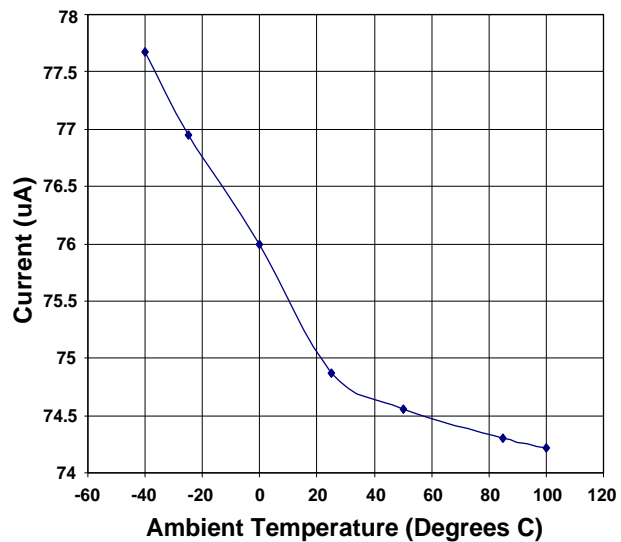

Figure 14 - Example of VDD48I / VDD48O / Converter Output

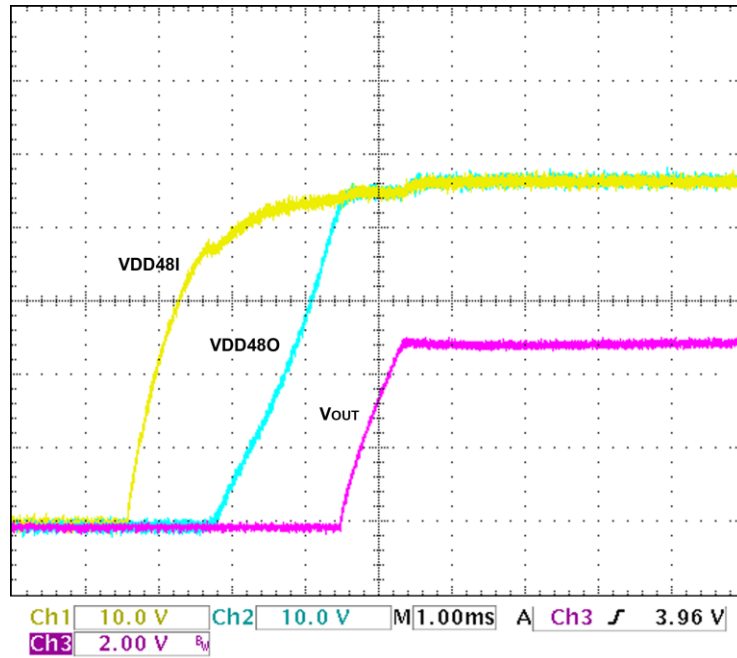

Figure 15 - PI Input Voltage and Current / ATDET

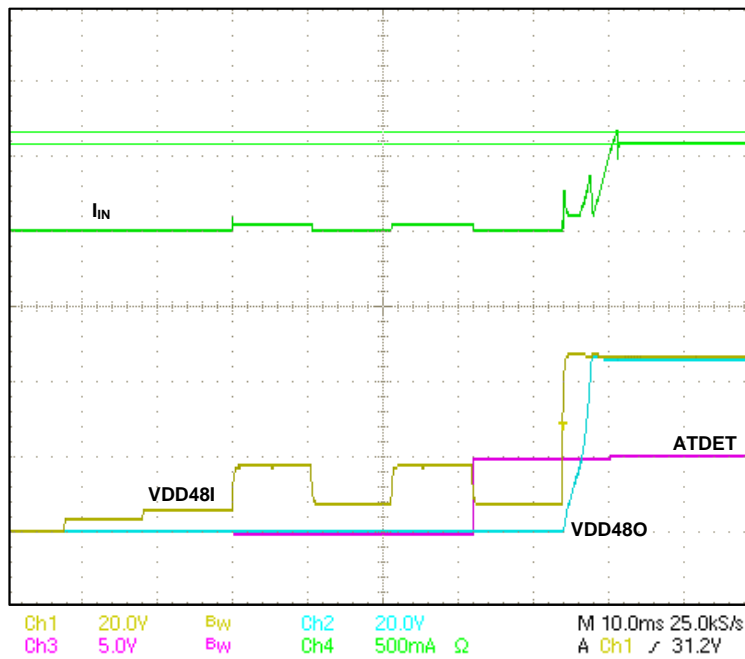

Figure 16 - 3.3V 30W DC-DC Efficiency vs. Load

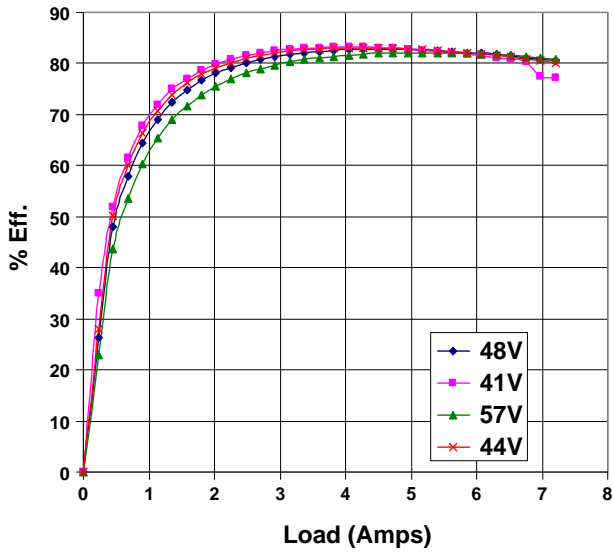

Figure 18 - 3.3V 30W Load Regulation

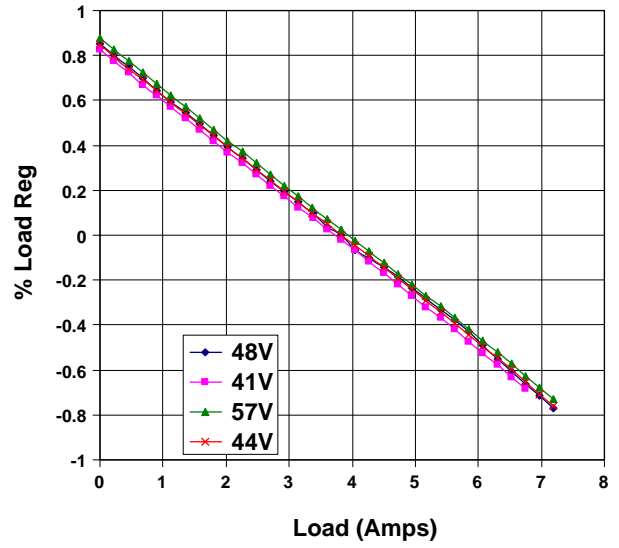

Figure 17 - 3.3V 30W End-End Efficiency vs. Load

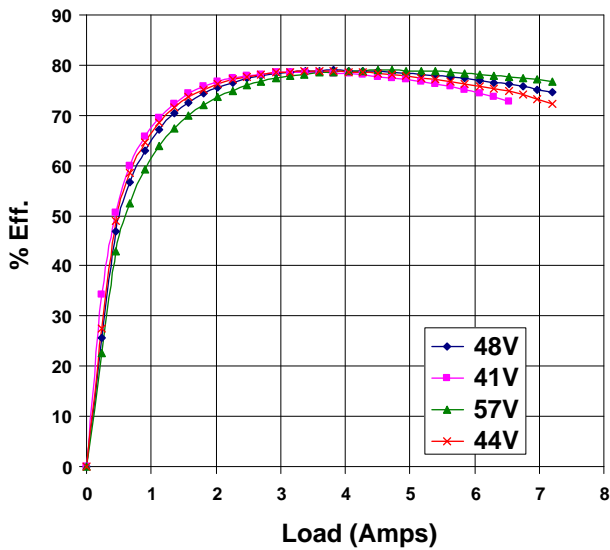

Figure 19 - 3.3V 30W Line Regulation

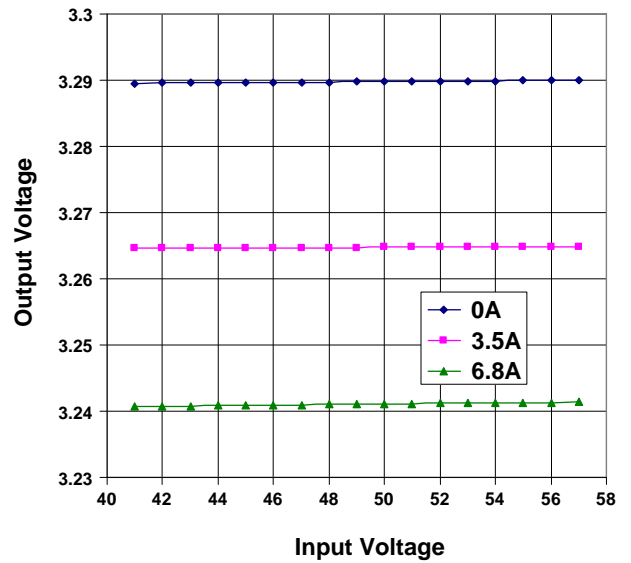

Figure 20 - 5V 30W DC-DC Efficiency vs. Load

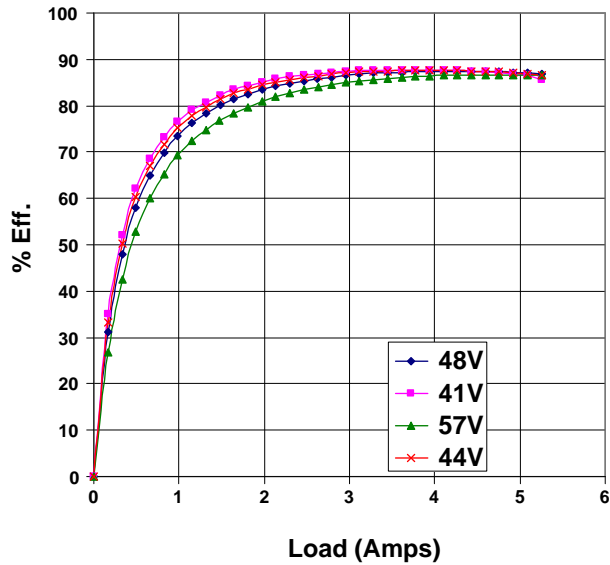

Figure 22 - 5V 30W Load Regulation

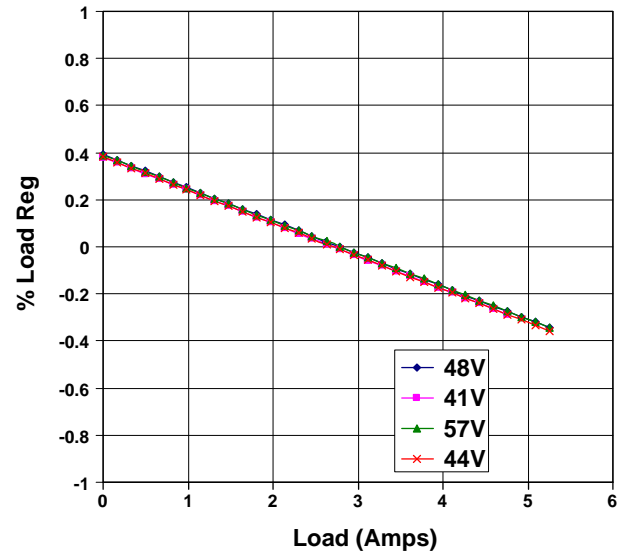

Figure 21 - 5V 30W End-End Efficiency vs. Load

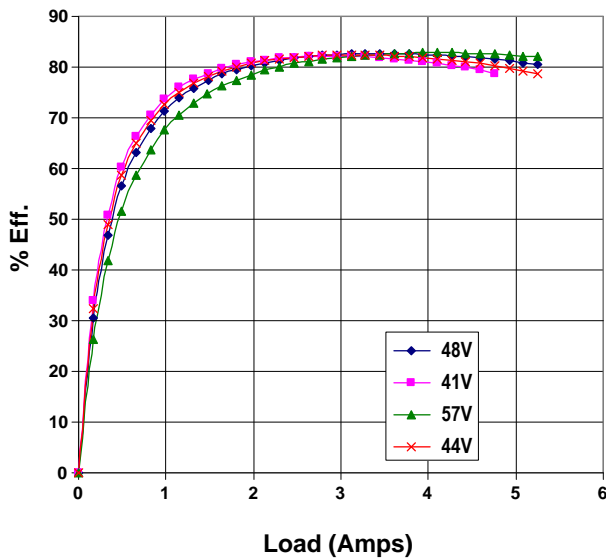

Figure 23 - 5V 30W Line Regulation

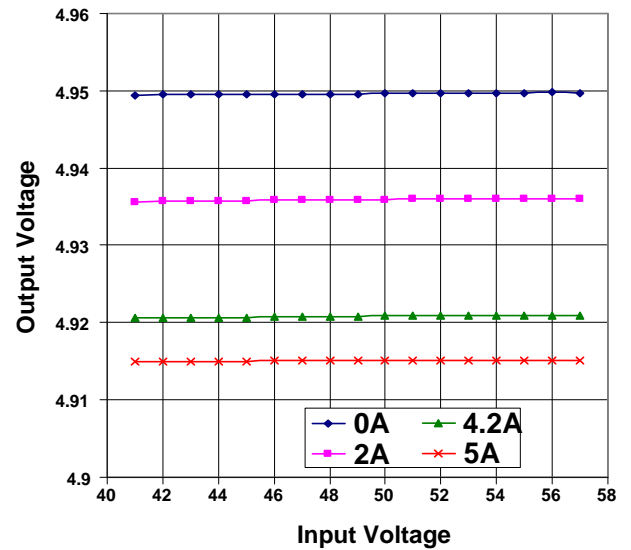

Figure 24 - 12V 30W DC-DC Efficiency vs. Load

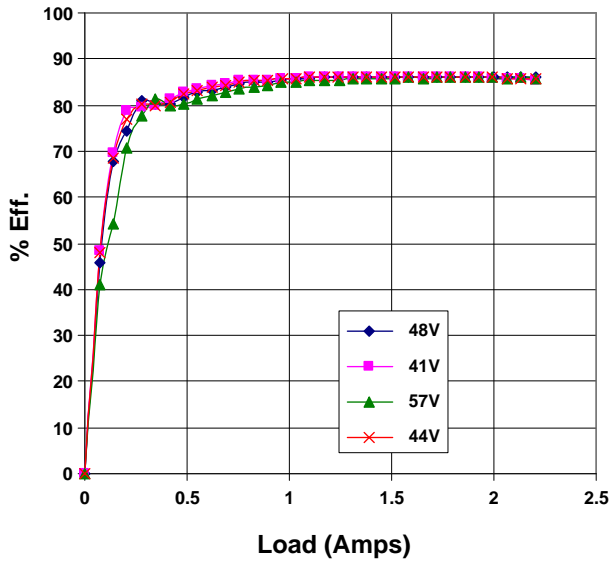

Figure 26 - 12V 30W Load Regulation

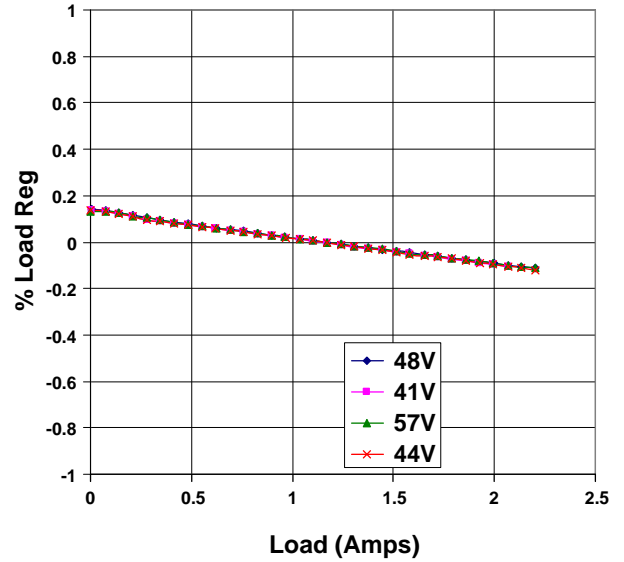

Figure 25 - 12V 30W End-End Efficiency vs. Load

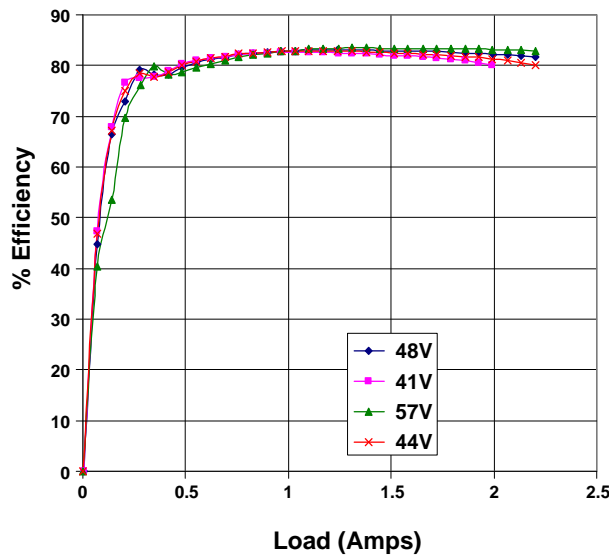
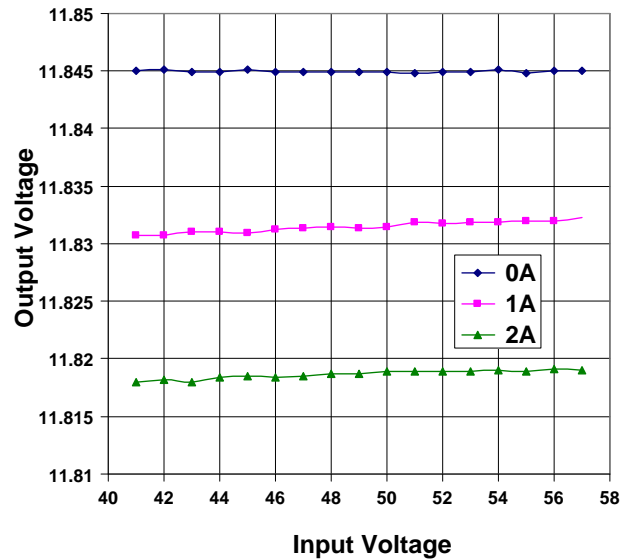

Figure 27 - 12V 30W Line Regulation



FUNCTIONAL DESCRIPTION

OVERVIEW OF POE

Power over Ethernet (PoE) offers an economical alternative for powering end network appliances, such as IP telephones, wireless access points, security and web cameras, and other powered devices (PDs). PoE standards IEEE® Std. 802.3af and 802.3at are intended to unify the delivery method of usable power over Ethernet cables to remotely powered client devices. These standards define a method for detecting and querying PDs and then supplying a range of current levels based on the power class the device belongs to. By employing this method, designers can create systems that predict and minimize power usage, allowing the maximum number of devices to be supported on a powered Ethernet network.

The power source that provides current through the Ethernet cables to remote devices is referred to as the Power Sourcing Equipment (PSE). The powered device (PD) on the other end of the Ethernet cable negotiates for and receives the agreed-upon power. IEEE® Std. 802.3af limits PSE power delivery to <13W at the PD input (Type 1 PD). IEEE® 802.3at allows for >13W power levels (Type 2 PD).

The PSE uses the following 802.3af sequence to detect a connected PD, determine how much power it requires and then initiate supply current to the device:

- **Reset** — Power is withdrawn from the PD if the applied voltage falls below a specified level.
- **Signature Detection**, — The PSE detects and evaluates whether the PD is a valid PoE device.
- **Classification** — The PSE reads the power requirement of the PD. The Classification level identifies how much power the PD will require from the Ethernet line. This permits optimum use of the total power available from the PSE. Classification is considered optional by IEEE® standard 802.3af-2005 but IEEE® standard 802.3at-2009 requires Type 2 PSE to classify the PD for mutual identification.
- **On** — Operational state, during which the PSE provides the allocated power level to the PD.

This sequence occurs as a progressively rising voltage level from the PSE. It is designed to prevent high voltages from being present on an Ethernet line that does not have a valid PD attached (for user and non-PoE device safety).

To design PoE systems according to IEEE® standards, the following constraints apply:

Table 6 - PoE Requirements	
Requirement	Value
Maximum Type 1 PD input power	12.95W
Maximum Type 2 PD input power	25.5W
Output voltage from Type 1 PSE	44-57V
Output voltage from Type 2 PSE	50-57V
Minimum operating current limit, Type 1 @ PSE min output voltage	350mA
Minimum operating current limit, Type 2 @ PSE min output voltage	600mA
Line resistance, Type 2 operation	12.5Ω
Input voltage at Type 1 PD interface	37V-57V
Input voltage at Type 2 PD interface	42.5V-57V

AS1135 POE DESIGN

To help designers meet these requirements, the AS1135 is a fully integrated PoE PD controller for Type1 and Type2 PD implementations. The AS1135 meets all system requirements for the IEEE® 802.3 standard for Ethernet and all power management requirements for IEEE® standard 802.3at-2009.

The AS1135 acts as an interface to the PSE, performing all detection, classification, and inrush current limiting control necessary for compliance with the PoE standards. An internal MOSFET and control circuit limits the inrush and steady-state current drawn from the Ethernet line. External diode bridges protect against polarity reversal, to provide alternative A and B detection.

The AS1135 also passes the 8kV Contact Discharge and 15kV Air Discharge requirements, tested per IEC 61000-4-2. EMI compliance of AS1135-based designs has been verified for CISPR22 and FCC Class-B radiated and conducted emissions.

POWER FEED ALTERNATIVES FOR 10/100/1000 ETHERNET SYSTEMS

The Power Sourcing Equipment (PSE) supplies power to a single PD per node. A PSE located in the Data Terminal Equipment or Repeater is called an endpoint PSE, while a PSE located between MDIs is called a Mid-span PSE. Figure 28 illustrates the power feed options allowed in the 802.3at-2009 standard for 10/100/1000 Ethernet systems.

In Alternative A, a PSE powers the end station by feeding current along the twisted pair cable used for the 10/100/1000 Ethernet signal via center taps on the Ethernet transformers. On the line side of the transformers for the PD, power is delivered through pins 1 and 2 and returned through pins 3 and 6.

In Alternative B, a PSE powers the end station by feeding power through pins 4, 5, 7 and 8. In a 10/100/1000 system, this is done through the center taps of the Ethernet transformer. In a 10/100 system, power is applied directly to the spare cable pairs without using transformers.

The IEEE® Std. 802.3at-2009 standard is intended to be fully compliant with all existing non-powered Ethernet systems. As a result, the PSE is required to detect via a well-defined procedure whether or not the connected device is PD compliant and classify (optional in legacy 802.3af-2005 applications) the needed power prior to supplying it to the device. Maximum allowed voltage is 57V to stay within SELV (Safety Extra Low Voltage) limits.

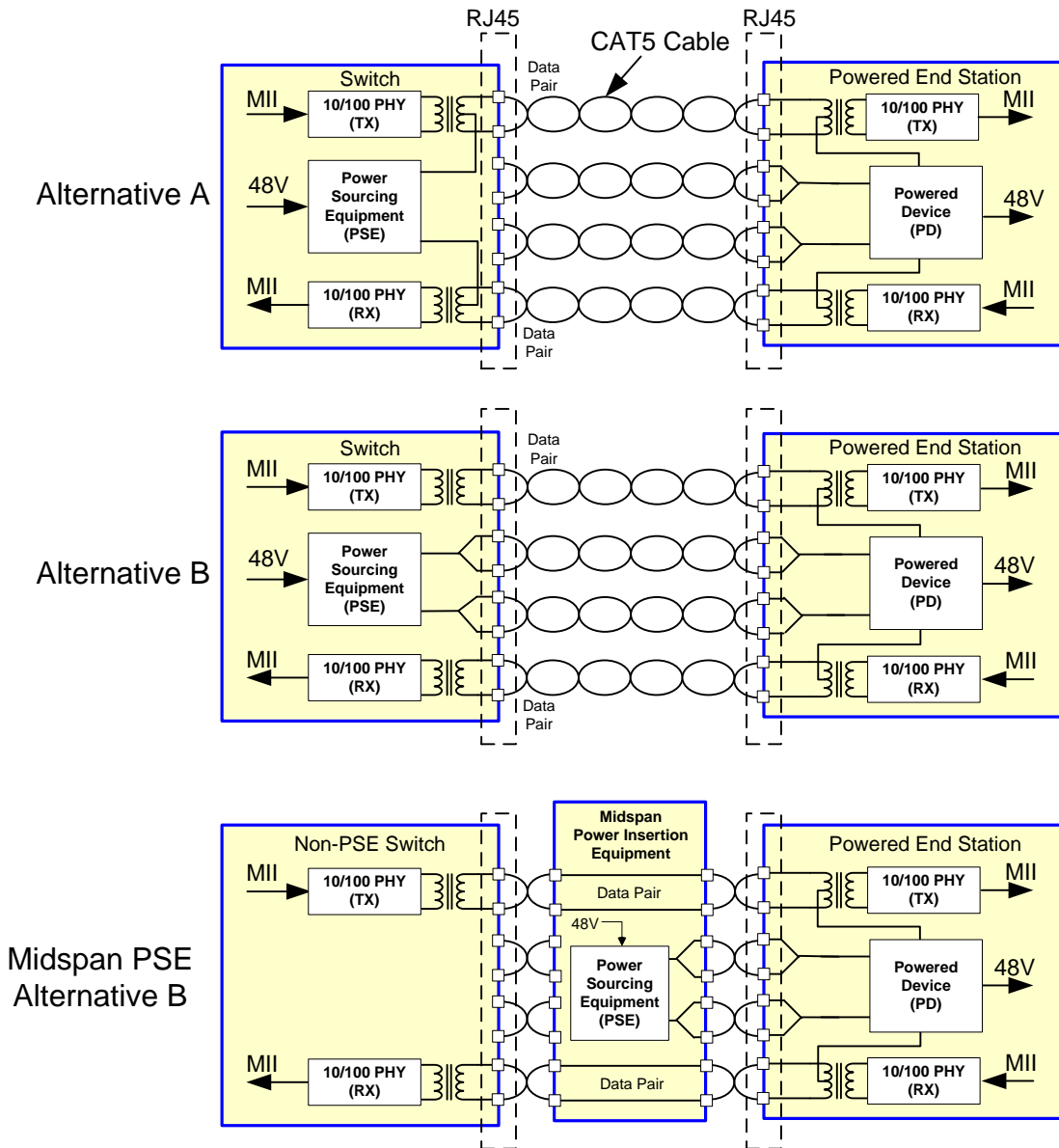

Figure 28 - IEEE® Std. 802.3at-2009 Power Feeding Schemes for 10/100 Systems

AS1135 OVERVIEW

The AS1135 is a fully integrated PD that provides the functionality required for Power-over-Ethernet (PoE) applications. The optimized architecture reduces external component cost in a small footprint while delivering high performance.

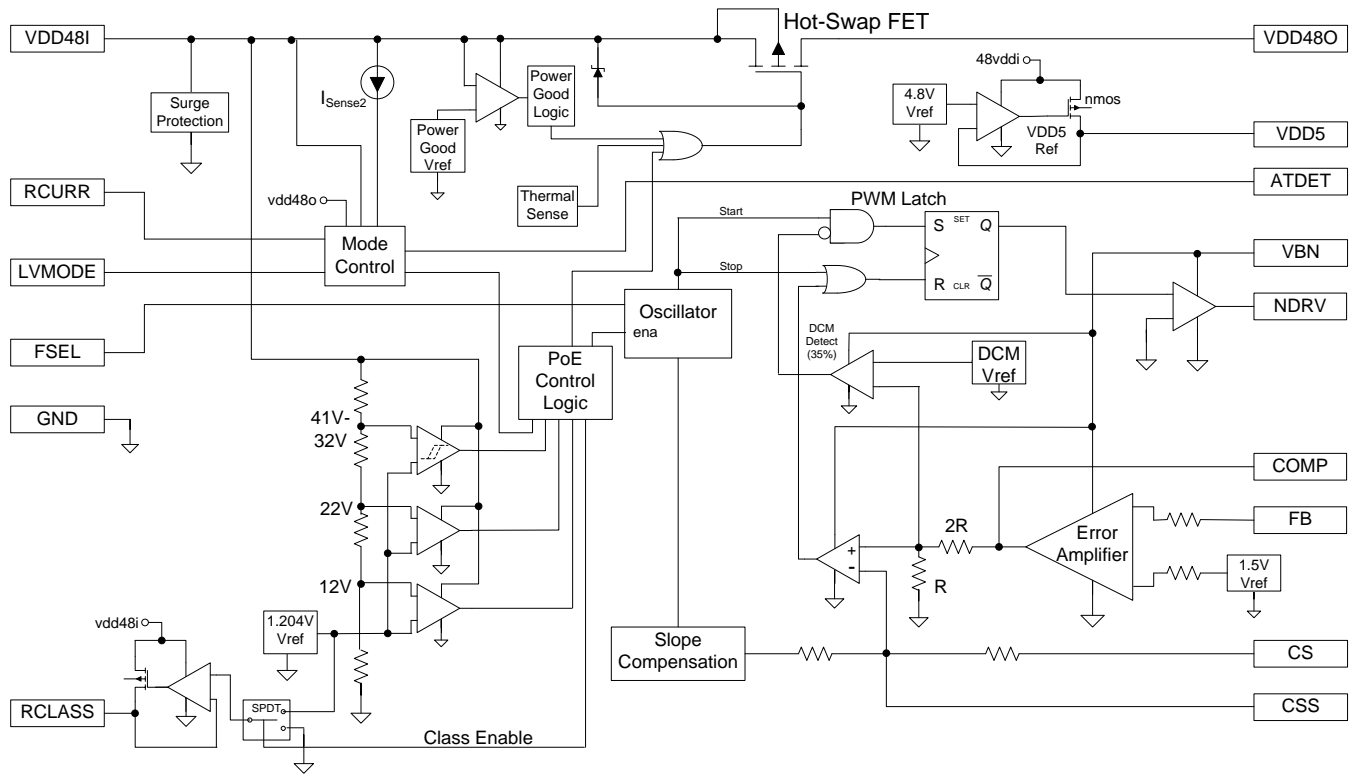

Figure 29 - AS1135 Top-Level Block Diagram

RECTIFICATION AND PROTECTION

To protect against polarity reversal, an external diode bridge is required. In conjunction with the external diode bridge, the AS1135 provides over-voltage and transient protection on the line side of the Hot-Swap FET.

The AS1135 is implemented in a robust 100V process technology. By integrating robust input protection circuitry, Akros Silicon has produced a solution that provides much faster response to surge events. The design also limits stray surge current from passing through sensitive circuits, such as the Ethernet PHY device and enables low-impedance safe discharge paths directly to earth ground. The protection circuit has been carefully designed to ensure that during these surge events, where currents can reach as high as 30A, voltages do not exceed critical breakdown and spark gap limits, protecting the PD from damage by the event. This enables system designers to achieve 15kV/8kV Air/Contact Discharge system ESD performance.

PD CONTROLLER

The AS1135 PD Control Interface is designed to provide full PD functionality for IEEE® 802.3af and 802.3at compliant systems, with programmable support for standard PD control functions.

The PD Controller provides the following major functions:

- A resistance/capacitance connection path for the detection signature.
- Classification current for power classification.
- Full 30Watt PD supply capability
- Power management and thermal protection override, including UVLO (Under Voltage Lock Out).
- ATDET signal output when connected to a Type 2 PSE that can deliver more than 13Watts.
- 2-Event Physical Layer classification.
- Maintain Power Signature feature.

MODES OF OPERATION

The AS1135 has five operating modes:

1. **Reset** — All blocks are disabled.
2. **Detection** — The external PD detection signature resistance / capacitance components are applied across the input.
3. **Classification** — PD indicates power requirements to the PSE via a Single-Event Classification for 802.3af or a 2-Event Physical Layer Classification for 802.3at.
4. **Idle** — This state is entered after Classification, and remains until full-power input voltage is applied.

5. **On** — The PD is enabled, and supplies power to the DC-DC controller and the local application circuitry.

As the supply voltage from the PSE increases from 0V, the AS1135 transitions through the modes of operation in this sequence:

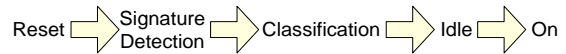

If no PSE or local power supply is present, line voltage will be zero, which will hold the AS1135 in the Reset state. The AS1135 does not affect the Ethernet link function.

Reset

When the voltage supplied to the AS1135 drops below the minimum valid detection voltage (i.e. <2.7V), the chip will enter the Reset state. While in Reset, the power supply to the PD is disconnected, the AS1135 consumes very little power and the device reverts to the pre-detection status.

Detection Mode

During the detection sequence, the PSE applies a voltage to the PD to read its detection signature. The reading of the signature determines if a PD is present.

During detection, the PSE applies two sequential voltages, 1V or more apart, within the detection voltage range of 2.7V to 10.1V. It extracts a detection signature resistance value from the incremental I-V slope. Valid I-V slope resistance values are between 23.75kΩ and 26.25kΩ.

With the AS1135, detection signature resistance is generated by an external resistor connected between VDD48I and GND. Typically this is a 26.7kΩ, 1% resistor. With this value of $R_{SIGNATURE}$, the PSE normally detects a total effective signature resistance of approximately 25kΩ, which is centered within the 802.3af/at specification range of 23.75kΩ to 26.25kΩ.

Valid PD detection also requires a valid detection signature capacitance of 0.05 to 0.12μF at 2.7 to 10.1V, and 1.9V maximum offset voltage, per the IEEE® 802.3af/at standard, measured at the PD input connector. AS1135 detection signature capacitance is generated by an external 0.1μF capacitor connected between VDD48I and GND. The offset voltage is mainly provided by the external diode bridge voltage drop.

Classification Mode

Each class represents a power allocation range for a PD to assist the PSE in managing power distribution. IEEE® Std. 802.3at defines classes of power levels for PDs, listed in Table 7. The AS1135 supports 2-Event Physical Layer classification, per IEEE® Std. 802.3at, as shown in Figure 30.

The AS1135 identifies the PSE as either Type 1 or Type 2. If the 2-Event method is detected by the PD controller during the classification stage, it asserts the ATDET pin high, indicating connection to a Type 2 PSE. If the PD controller detects only single-event classification, it identifies the PSE to be Type 1 and the ATDET pin is asserted low.

In real applications, noise or transient ringing on the line during classification phase can lead to false 2-event classification or Type 2 PSE detection. To prevent such false positives, the AS1135 integrates a proprietary digital filter to filter out noise events as long as 100uS during the classification phase, ensuring a very reliable AT Detection.

If a PSE is Type 1, to classify the AS1135, the Type 1 PSE presents a voltage between 14.5V and 20.5V to the PD and determines its class by measuring the resulting PD load current.

If a PSE is Type 2, in order to classify the AS1135 as the Type 2 PD, AS1135 has to be set as Class 4 (classification setting shown in Table 7), so that AS1135 returns a Class 4 signature.

The AS1135 allows the user to program the classification current via an external resistor connected to the RCLASS pin. Current, power levels and programming resistor values for each class are shown in Table 7. Note that for Class 0, Rclass pin needs to be Pulled Up to VDD5 pin. This can be a direct short to VDD5 or using a resistor up to 100kΩ.

Use the following equation to determine the typical classification current:

$$I_{CLASS}[mA] = 2.0 + \frac{2360}{R_{CLASS}[k\Omega]}$$

$$\text{Tolerance} = \text{Maximum of } \pm 1.8\text{mA or } \pm 9\% \\ R_{CLASS} > 63.4\text{k}\Omega$$

Once the classification process is done, the PD removes the classification current to conserve power.

Note: During the classification of a Type 2 PD, the PSE outputs a sequence of voltage signals (Class 1, Mark 1, Class 2, Mark 2, Class 3) within the specific timing requirement. The PD has to respond within the limit range of voltage/current/impedance for each event according to section 33.3.5 PD Classifications of 802.3at standard.

Table 7 - Classification Settings

Class	Power (W)	I _{CLASS} (mA)	R _{CLASS} (kΩ)
0	0.44-12.95	0-4 mA	Pull-up (0-100kΩ) to VDD5 pin
1	0.44-3.84	9-12 mA	280kΩ, 1%
2	3.84-6.49	17-20 mA	143kΩ, 1%
3	6.49-12.95	26-30 mA	90.9kΩ, 1%
4	12.96-25.5	36-44 mA	63.4kΩ, 1%

Idle Mode

After the classification process, the PD enters Idle mode while it waits for On-state power delivery from the PSE. PD Current usage is limited to monitoring circuitry to detect the On-state voltage threshold.

On State

In the On state, the AS1135 is supplying power across the Ethernet line(s) to the PD. At a voltage at or below 42V, the PD turns on and full power is available via the AS1135 DC-DC Controller.

POE POWER-ON STARTUP WAVEFORM

Figure 30 represents the power-on sequence for PoE operation. The waveform reflects typical voltages present at the PD during signature, classification and power-on.

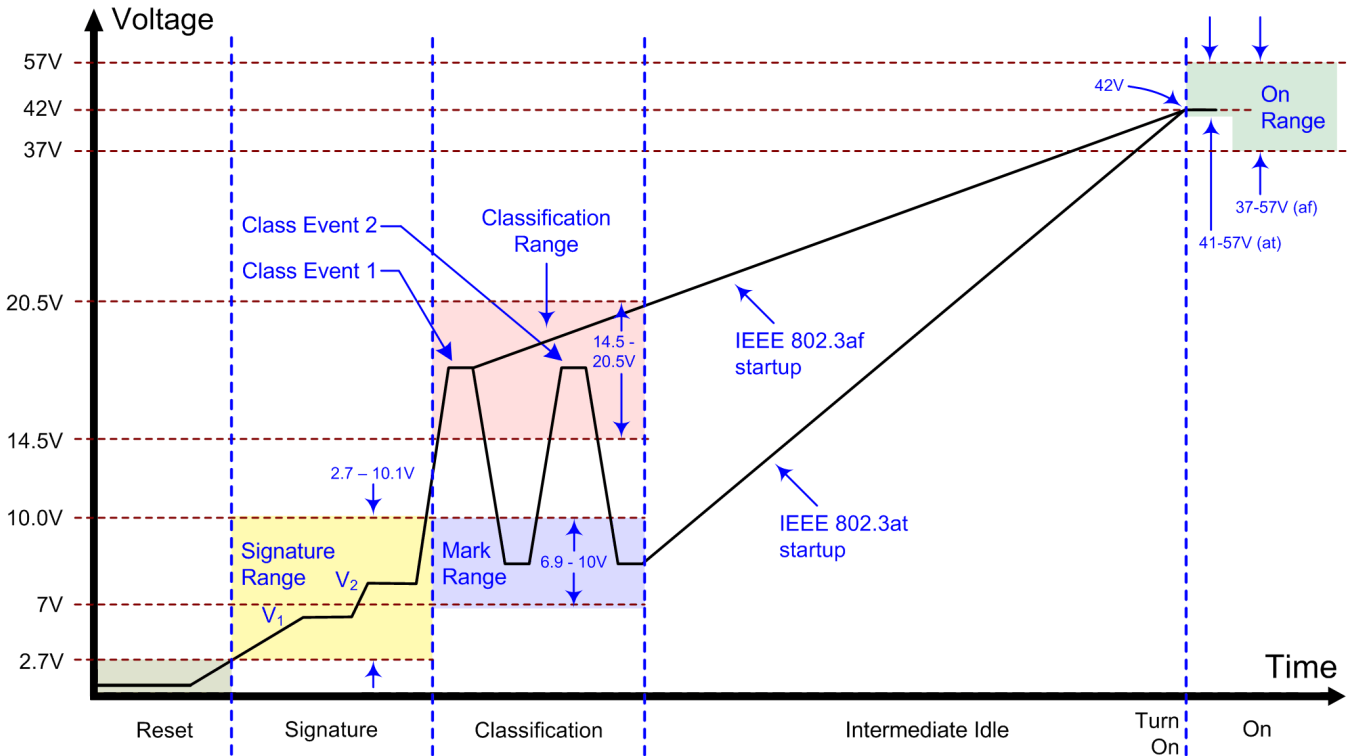

1. Voltages V_1 and V_2 are applied by the PSE to extract a signature value.
2. The PSE takes current/impedance readings during Class/Mark Events to determine the class of the PD. At this time, the PD presents a load current determined by the resistance connected to the R_{CLASS} pin.
3. After the PSE measures the PD load current, if it is a high-power PSE, it presents a mark voltage (6.9-10V), followed by a second classification voltage. The PD responds by presenting a load current as determined by the resistor on the R_{CLASS} pin. After the PSE measures the PD load current the second time and determines that it can deliver the requested power, it moves into the On state by raising the voltage to approximately 42V.

Figure 30 - 802.3at Typical Power-On Waveform

MAINTAIN POWER SIGNATURE (MPS)

The PSE requires the PD to provide an appropriate power signature in order to maintain power to the device. The AS1135 provides an internal circuit to maintain the minimum 10mA of DC current required to present a valid Maintain Power Signature indication to the PSE. At the no-load or start-up stage, the PD will consume the minimum 10mA. Once the application load is established on the DC-DC converter output stage, the PD internal load circuitry for MPS is turned off to reduce the total chip power consumption.

PD CONTROLLER POWER AND THERMAL PROTECTION

The AS1135 provides the following PD controller power and thermal protection:

- Under Voltage Lock Out (UVLO)
- Inrush Current Limit with integrated current sense
- Thermal Limit / Protection

Under Voltage Lock Out (UVLO)

The AS1135 contains line Under-Voltage Lock Out (UVLO) circuitry to determine when to power on the PD. If the PSE supply voltage at PD PI is equal or greater than UVLO V_{IN_RISING} , the AS1135 PD will power on and run; if the PSE supply voltage at PD PI drops below UVLO $V_{IN_FALLING}$, the AS1135 PD will power off. The PD circuit controls power flow to the DC-DC controller, to protect the PD from erratic operation or damage.

Inrush Current Limit / Current Sense

Inrush limiting maintains the cable voltage above the turn-off threshold as the input capacitor charges. This also prevents the PSE from going into current limit mode. The Current Limit/Current Sense circuitry also minimizes the PD on-chip temperature peaks by limiting both inrush and operating current.

Current is monitored with an integrated sense circuit that regulates the gate voltage on an integrated low-leakage power MOSFET. The power MOSFET can also be shut off completely by either the PD Controller, the Thermal Limit Protection circuitry or the insertion of a local power adapter that causes the LVMODE pin to be pulled high (via a resistor divider).

During the PD startup sequence, V_{DS} across the Hot-Swap FET is momentarily high as the VDD480 output capacitance is charged up, as illustrated in Figure 14. During this state, the Hot-Swap FET experiences a high instantaneous power drop and heating. Therefore, it is recommended that during this startup sequence, the incoming current should only be utilized for the charging of the VDD480 node, to minimize the startup time and associated power drop across the FET. The primary

PWM controller is designed to accommodate for VDD480 startup before drawing power from the line. However, if the application requires direct use of the VDD480 node for other functions, the startup of those circuits should be delayed until the VDD480 node has reached its full voltage level.

Thermal Limit / Protection

The AS1135 provides thermal protection for itself by monitoring die temperature and reducing maximum current or disconnecting power as needed to prevent its pre-set thermal limits from being exceeded. Two-stage thermal current limiting is implemented, which reduces the operating current limit by 50% when the die temperature reaches 145°C, and disables the power MOSFET switch above 165°C. Normal current limits in both cases are re-applied when the die temperature returns below 125°C.

SHORT-CIRCUIT PROTECTION

Optional short-circuit protection for the device may be added externally to the AS1135; to limit PD input current or shut down the IC if a short occurs in the application hardware.

The example circuit, Figure 31 (simplified representation), uses a drop in voltage on the bias winding of the DC-DC converter transformer to detect a short at the transformer output. The bias winding generates an intermediate voltage (e.g. 6.5V) when the PD is operating normally, but will sympathetically drop below 1V if the transformer output becomes shorted. Refer to the Akros Reference Designs for a complete short-circuit protection schematic.

A PNP transistor is gated with the bias winding voltage such that it remains off when the transformer is operating normally. When a short occurs at the transformer output, the bias winding voltage drops down and forces the transistor on. The activated transistor pulls the compensation line voltage down, limiting PD input current to a safe level until the short is removed.

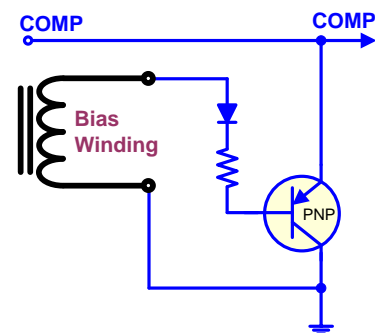

Figure 31 - Short-Circuit Protection

ATDET PIN

The ATDET output pin provides an indicator when 2-event classification is detected by being linked to a Type 2 PSE, or through the use of a local power supply that uses the LVMODE feature. This indicates system has more than 13W of available power. This pin can be used by the PD system controller to self-configure the application device based on available power.

If there is no local power present, ATDET will stay low during PD Reset, Detection and Classification phases. The ATDET pin will be set high once the PD recognizes the completion of the 2-Event Physical Layer Classification, as initiated by a Type 2 PSE. The pin will remain high and will only be reset low by the occurrence of a Reset or a power-down event. ATDET pin remains low if it identifies the PSE partner to be Type 1 during the Classification phase.

If LVMODE is asserted when supplying local power, the ATDET pin is forced high, irrespective of the PD mode. Please see Table 8 below for ATDET output definitions under various powering modes.

Table 8 - ATDET Truth Table		
ATDET signal status	PSE	
	Type 1	Type 2
LVMODE = Low	Low	High
LVMODE = High	High	High

LOCAL POWER MODE (LVMODE)

The LVMODE pin can be used in applications where the PD appliance is designed to draw power from either the Ethernet cable or an external DC local power adapter. The LVMODE pin is a current-mode input pin, with low and high thresholds as defined in the parametric tables (see Table 4). The LVMODE is asserted when the input current exceeds the IIH threshold, and is de-asserted when the input current is below the IIL threshold. If LVMODE operation is not desired, the LVMODE pin should be connected to GND.

Figure 32 below shows a simplified internal implementation and external application circuit required to use the LVMODE feature. When power is applied at the local adapter input, the AS1135 enters Local Voltage Mode. This opens the internal Hot-Swap FET switch while the DC-DC converter is in operation.

In this configuration, local power always takes priority, even in presence of PoE power, irrespective of their relative voltages. If local power is removed, the device will exit Local Voltage Mode operation and PoE power will be used, if available.

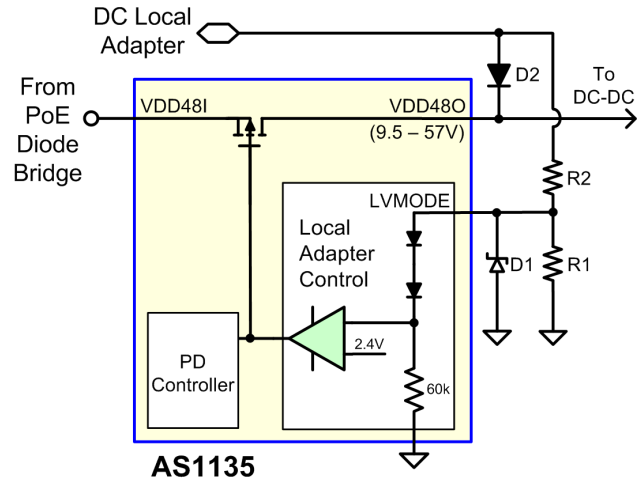

Figure 32 - LVMODE Implementation

Local power is inserted at the VDD48O node through an external diode (D2). Use of a low reverse-leakage diode is recommended (<350uA, at worst case temperature). This ensures that when there is no local power, PoE voltage at the VDD48O node will not falsely pull up the LVMODE pin due to high reverse leakage through the diode. Please see Table 9 for part number information.

An appropriate ratio of R2 and R1 resistors should be used to ensure proper operation across all supply voltages. Table 9 lists appropriate choices of R2 and R1 resistors to work with a variety of popular local adapter DC voltages. Though a common value of R2 and R1 can be used across the whole range of local supply voltages from 9.5V to 57V, using different value pairs, per the table below, will minimize power consumption. The maximum input voltage at the LVMODE pin should not exceed 6V, so a Zener diode (D1) is recommended to limit transient voltage excursions at the pin.

Since the input current at the LVMODE pin defines its state, it is not recommended to drive other circuits or components directly from the LVMODE node (such as an LED) that might draw current. LEDs or current-absorbing components may be driven directly from the Local Supply pin.

The AS1135 internal DC-DC controller is designed to operate with input voltages of 9.5V-57V, to allow applications to take advantage of the LVMODE feature. Besides configuring the device for operation from a local power source, the external power transformer must also be designed to ensure proper operation across the complete input range.

Table 9 - LVMODE Configuration

Local Voltage Range	Recommended Local Adapters	R2	R1
9.5V-57V	12V, 18V	2.74k Ω	4.02k Ω
20V-57V	24V, 30V	11.3k Ω	4.02k Ω
32.4V-57V	36V, 48V	20k Ω	4.02k Ω

Diode D1: 5.6V Zener, BZT56V
 Diode D2: S3B (100V/3A, worst-case reverse leakage <250 μ A), use of a low reverse-leakage diode with worst-case reverse leakage under high temperature <350 μ A is recommended.

DC-DC CONTROLLER

Overview

The DC-DC architecture is a current-mode controller configurable with external components to fly-back, forward or buck topologies. Both non-isolated and isolated topologies are supported.

As part of a full system-level solution to control EMI, Akros has focused significant attention on reducing switching noise in the integrated power converters through unique methods of shaping FET driver waveforms. Ground bounce is also reduced by minimizing dV/dt switching noise.

The integrated DC-DC controller operates from a switched input voltage (VDD480) and includes a programmable soft start and current limiting. Once input power is applied and enable signals are asserted, the DC-DC controller starts up. The controller provides a gate control signal, NDRV, to the external switching MOSFET and uses an external resistor to sense primary current in the transformer. It also provides for an 80% maximum duty cycle, programmable PWM switching frequency and a true voltage-output error amplifier.

Programmable PWM Frequency

The FSEL pin allows the DC-DC converter switching frequency to be set externally. Placing a resistor between FSEL and GND sets the internal oscillator's frequency. Table 10 identifies the resistor values for some commonly-used switching frequencies.

Table 10 - PWM Switching Frequency Selection

Switching Frequency (kHz)	FSEL Resistor (k Ω , 1%)
100 (kHz)	178k Ω
225 (kHz)	100k Ω
350 (kHz)	53.6k Ω
500 (kHz)	36.8k Ω

Current-Limit/Current Sense

The DC/DC controller provides cycle-by-cycle current limiting, to ensure that transformer primary-current limits are not exceeded. In addition, the maximum average current in the transformer primary is set by internal duty-cycle limits.

Low Load Current Operation

The internal circuitry detects a low output power condition and puts the DC-DC Controller into a discontinuous current operation (DCM) mode.

Compensation and Feedback

For isolated applications, loop compensation and output voltage feedback is generally provided by an opto-isolator circuit, and the Feedback pin (FB) is tied to ground. In these applications, the COMP pin is pulled up to approximately 4.8V by an internal current source. This pull-up can be the termination for an opto-isolator, or, an additional resistor can be used in parallel.

For non-isolated applications, a resistive divider network, connected directly to the FB pin, senses the output voltage. The internal error amplifier is connected to a 1.5V reference voltage and the control loop will servo the FB pin to this voltage. A capacitive/resistive network connected to the COMP pin provides loop compensation.

Soft-Start inrush current limit

The internal circuitry automatically ramps up the inrush current by limiting the maximum current allowed in the transformer primary magnetizing inductance per clock cycle. The amount of time required to perform a soft start cycle is determined by the CSS capacitor. A value of 330nF provides approximately 7ms of soft startup ramp time.

DC-DC CONVERTER TOPOLOGIES

Isolated Topologies

The DC-DC controller can be configured in several different isolated topologies. The Flyback mode is chosen when a minimum number of external components is desired, or there is a large step-down and the output voltage is < 7V.

The Forward mode is chosen when lower switching noise is desired. Either of these isolated topologies can be designed for synchronous or non-synchronous operation, based on system requirements. A reference schematic for a High-Efficiency Isolated Synchronous Flyback design is shown in Figure 33.

Non-Isolated Topologies

The Buck mode is used in non-isolated applications. This application uses inductor for energy storage, instead of a transformer.

Buck designs have the smallest overall footprint. Figure 34 shows a reference schematic for a BUCK converter design in a non-synchronous operation mode, where the output voltage is referenced to VDD48O. Since the FB voltage is ground referenced, the feedback signal must be level-shifted back down to ground. This is accomplished by the two PNP transistors and associated resistors.

APPLICATION CIRCUITS

Figure 33 - PoE PD Controller with High-Efficiency Isolated Synchronous Flyback DC-DC Converter

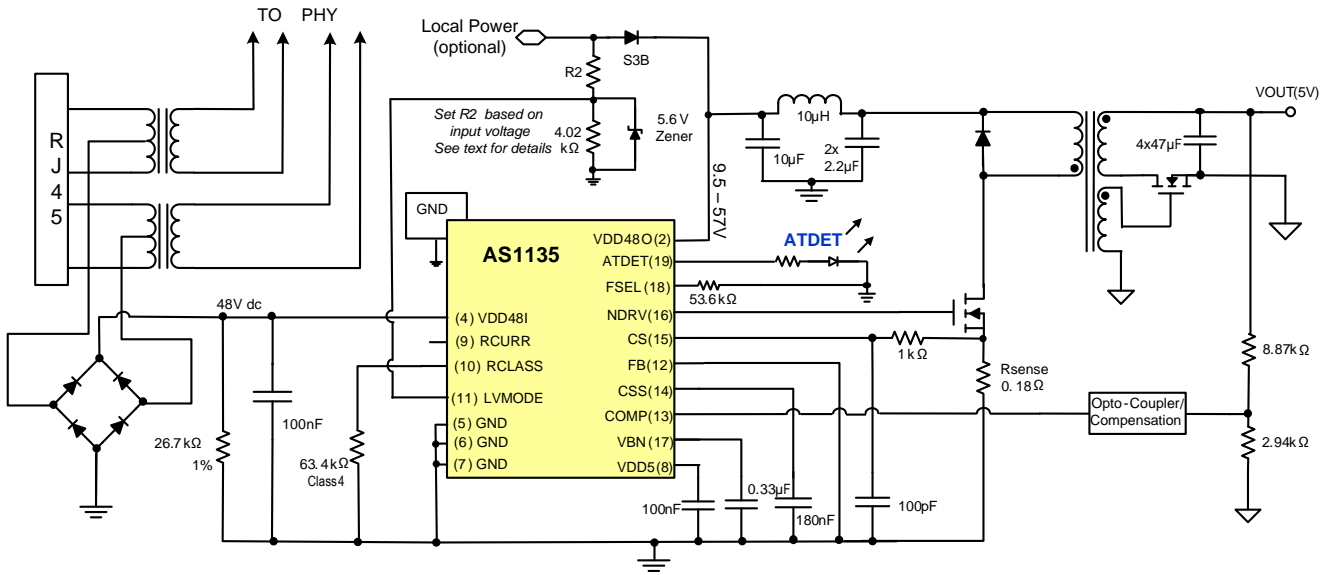

Note: This is a simplified conceptual schematic. Please refer to the reference design documentation for detailed design and component information. Full PoE implementation will require two input diode bridges. For simplicity, only one is shown here.

Figure 34 - PoE PD Controller with Non-Isolated BUCK DC-DC converter

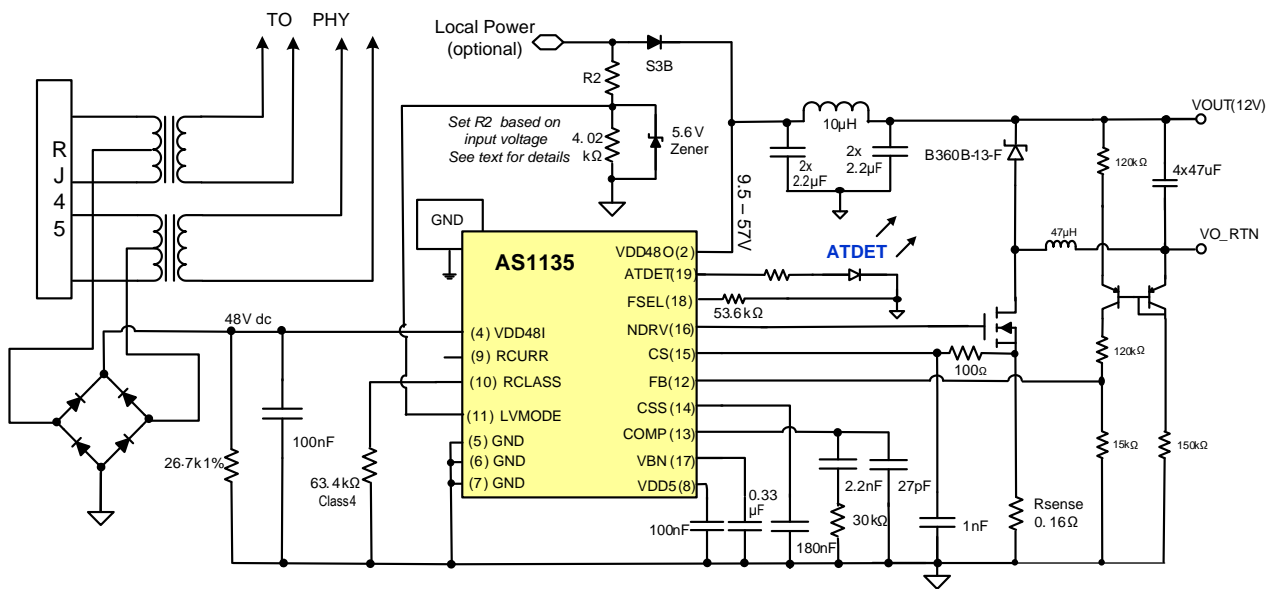

Note: This is a simplified conceptual schematic. Please refer to the reference design documentation for detailed design and component information. Full PoE implementation will require two input diode bridges. For simplicity, only one is shown here.

THERMAL DE-RATING AND BOARD LAYOUT CONSIDERATIONS

The AS1135 is capable of operating to an industrial temperature range of 85 °C in ambient air and without forced cooling. A thermal pad on the underside of the package dissipates the heat generated by the PD die.

In 30W applications, designers must consider thermal dissipation as an integral part of their system architecture and plan to remove heat via this pad.

If the PCB landing pattern is properly designed, the QFN package should exhibit a thermal resistance of $\Theta_{JA}=31^{\circ}\text{C}/\text{W}$. For adequate heat dissipation, the board layout must include a ground pad which provides both the ground connection and dissipates the heat energy produced in the chip. Thermal vias are used to draw heat away from the PD package and to transfer it to the backside of the system PCB.

The recommended PCB layout for the AS1135 is shown in Figure 35 below:

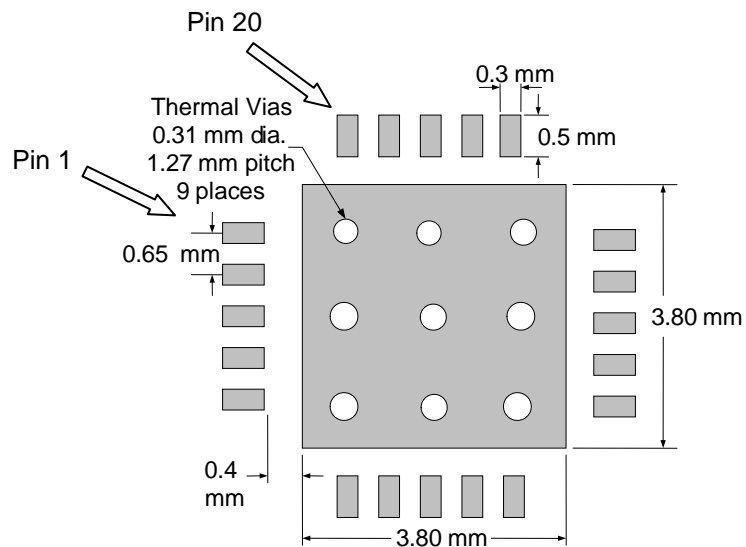
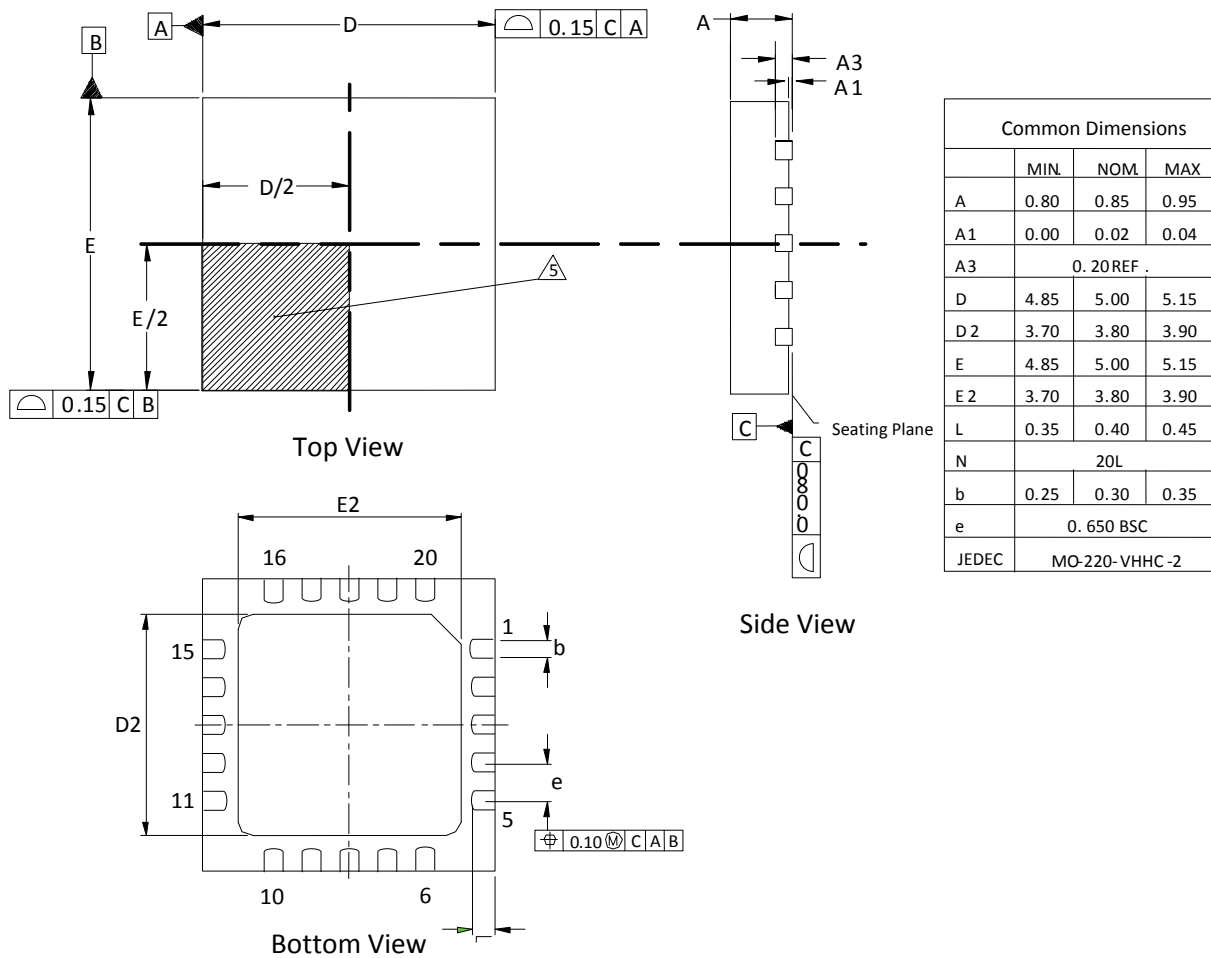

Figure 35 - AS1135 PCB Footprint (Top View)

PHYSICAL DIMENSIONS

20 Pin QFN Package, 5mm X 5mm



NOTES

1. Controlling dimensions in mm.
2. Dimension tolerances are ± 0.1 (angular tolerance $\pm 3^\circ$) unless otherwise specified.
3. All dimensions and tolerances conform to ANSI 14.5M-1994.
4. Co-planarity applies to exposed pad as well as the terminals.
5. Pin 1 location may be identified by either a mold or marked feature.
6. JEDEC reference MO-220.

Figure 36 - Physical Dimensions

CONTACT INFORMATION

Akros Silicon, Inc.
262 Santa Ana Court
Sunnyvale, CA. 94085
USA

Tel: (408) 746-9000
Email inquiries: Marcom@AkrosSilicon.com
Website: www.AkrosSilicon.com

IMPORTANT NOTICES

LEGAL NOTICE

Copyright © 2011 Akros Silicon™. All rights reserved. Other names, brands and trademarks are the property of others. Akros Silicon™ assumes no responsibility or liability for information contained in this document. Akros reserves the right to make corrections, modifications, enhancements, improvements, and other changes to its products and services at any time and to discontinue any product or services without notice. The information contained herein is believed to be accurate and reliable at the time of printing.

REFERENCE DESIGN POLICY

This document is provided as a design reference and Akros Silicon assumes no responsibility or liability for the information contained in this document. Akros reserves the right to make corrections, modifications, enhancements, improvements and other changes to this reference design documentation without notice.

Reference designs are created using Akros Silicon's published specifications as well as the published specifications of other device manufacturers. This information may not be current at the time the reference design is built. Akros Silicon and/or its licensors do not warrant the accuracy or completeness of the specifications or any information contained therein.

Akros does not warrant that the designs are production worthy. Customer should completely validate and test the design implementation to confirm the system functionality for the end use application.

Akros Silicon provides its customers with limited product warranties, according to the standard Akros Silicon terms and conditions. For the most current product information visit us at www.AkrosSilicon.com

LIFE SUPPORT POLICY

LIFE SUPPORT: AKROS' PRODUCTS ARE NOT DESIGNED, INTENDED, OR AUTHORIZED FOR USE AS COMPONENTS IN LIFE SUPPORT DEVICES OR SYSTEMS. NO WARRANTY, EXPRESS OR IMPLIED, IS MADE FOR THIS USE. AUTHORIZATION FOR SUCH USE SHALL NOT BE GIVEN BY AKROS, AND THE PRODUCTS SHALL NOT BE USED IN SUCH DEVICES OR SYSTEMS, EXCEPT UPON THE WRITTEN APPROVAL OF THE PRESIDENT OF AKROS FOLLOWING A DETERMINATION BY AKROS THAT SUCH USE IS FEASIBLE. SUCH APPROVAL MAY BE WITHHELD FOR ANY OR NO REASON.

"Life support devices or systems" are devices or systems which (1) are intended for surgical implant into the human body, (2) support or sustain human life, or (3) monitor critical bodily functions including, but not limited to, cardiac, respirator, and neurological functions, and whose failure to perform can be reasonably expected to result in a significant bodily injury to the user. A "critical component" is any component of a life support device or system whose failure to perform can be reasonably expected to cause the failure of the life support device or system, or to affect its safety or effectiveness.

SUBSTANCE COMPLIANCE

With respect to any representation by Akros Silicon that its products are compliant with RoHS, Akros Silicon complies with the Restriction of the use of Hazardous Substances Standard ("RoHS"), which is more formally known as Directive 2002/95/EC of the European Parliament and of the Council of 27 January 2003 on the restriction of the use of certain hazardous substances in electrical and electronic equipment. To the best of our knowledge the information is true and correct as of the date of the original publication of the information. Akros Silicon bears no responsibility to update such statements.

Looking for pricing, stock, or lifecycle information?

Click below to explore more details on WIN SOURCE:

 [View AS1135 on WIN SOURCE](#)

 [Akros Silicon Information](#)

Optimize Your Supply Chain with WIN SOURCE Solutions

-  Global Sourcing Solution
-  Obsolete Management
-  Cost Control Management
-  Shortage Management
-  Alternative Solution
-  Excess Inventory Management