



**THE DATASHEET OF
RT8549LGQW**



24V/60V Boost Converter with SMBus Controlled 4-CH LED Driver

General Description

The RT8549L is a high efficiency Boost converter with 4-CH LED driver supporting 60V maximum output voltage. It is designed for LCD panel applications that employs LED as lighting sources. The Boost converter generates a suitable output voltage to drive four LED strings in parallel and supports up to 18 LEDs per string.

The RT8549L supports a wide input voltage range from 4.2V to 24V and provides a SMBus interface to control the LED brightness dimming mode, operating frequency and LED currents. The internal 150mΩ, 60V power switch with current-mode control provides high efficiency operation.

The RT8549L is available in the WDFN-16L 5x5 package to achieve optimized solution for PCB space.

Features

- Wide Operating Input Voltage : 4.2V to 24V
- Max 60V Output Voltage
- 3% LED Current Accuracy
- 2% LED Current Matching
- Low Drop Output 120mA/0.4V Current Sink
- SMBus Programs LED Current, Switching Frequency, Dimming Mode
- LED Current : 22.58mA to 180mA
- Switching Frequency : 200kHz to 900kHz
- Dimming Mode : PWM, DC, Mixed-Mode
- Built-in Input UVP, Output OVP, OCP, and Soft-Start
- Support LED Hot-plug, Open/Short Detection
- Low EMI, Low Acoustic Noise
- 16-Load WDFN Package
- RoHS Compliant and Halogen Free

Applications

- UMPC and Notebook Computer Backlight

Simplified Application Circuit

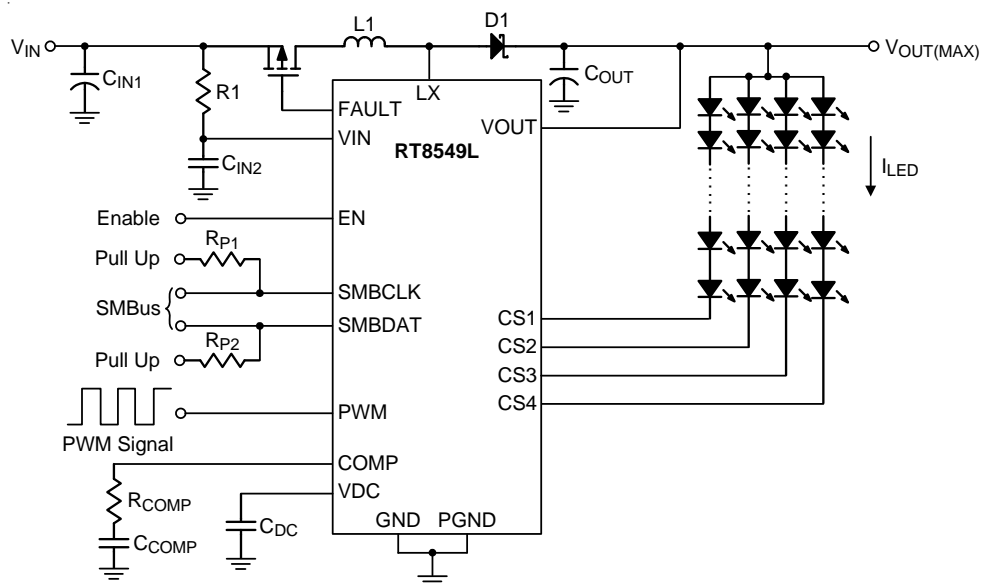

Ordering Information

RT8549L □ □

- Package Type
QW : WDFN-16L 5x5 (W-Type)
- Lead Plating System
G : Green (Halogen Free and Pb Free)

Note :

Richtek products are :

- ▶ RoHS compliant and compatible with the current requirements of IPC/JEDEC J-STD-020.
- ▶ Suitable for use in SnPb or Pb-free soldering processes.

Pin Configuration

(TOP VIEW)

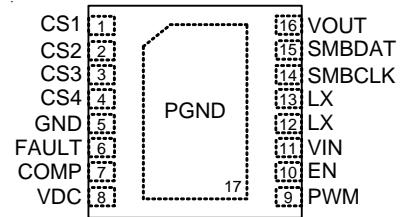

WDFN-16L 5x5

Marking Information

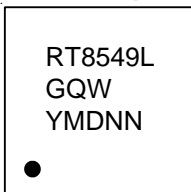

RT8549LGQW : Product Number

YMDNN : Date Code

Functional Pin Description

Pin No.	Pin Name	Pin Function
1	CS1	Current sink for LED channel 1.
2	CS2	Current sink for LED channel 2.
3	CS3	Current sink for LED channel 3.
4	CS4	Current sink for LED channel 4.
5	GND	Ground.
6	FAULT	Fault indicator output. When fault condition occurs, the FAULT pin will be pulled up to VIN.
7	COMP	Compensation note for error amplifier. Connect a compensation network to ground.
8	VDC	Output of internal regulator voltage. Connect a capacitor from this pin to ground.
9	PWM	PWM dimming control input.
10	EN	Enable control input. (active high).
11	VIN	Power supply input.
12,13	LX	Switch node of boost converter.
14	SMBCLK	Clock of SMBus.
15	SMBDAT	Data of SMBus.
16	VOUT	Over voltage protection sense input.
17 (Exposed Pad)	PGND	Ground. The exposed pad must be soldered to a large PCB and connected to PGND for maximum power dissipation.

Functional Block Diagram

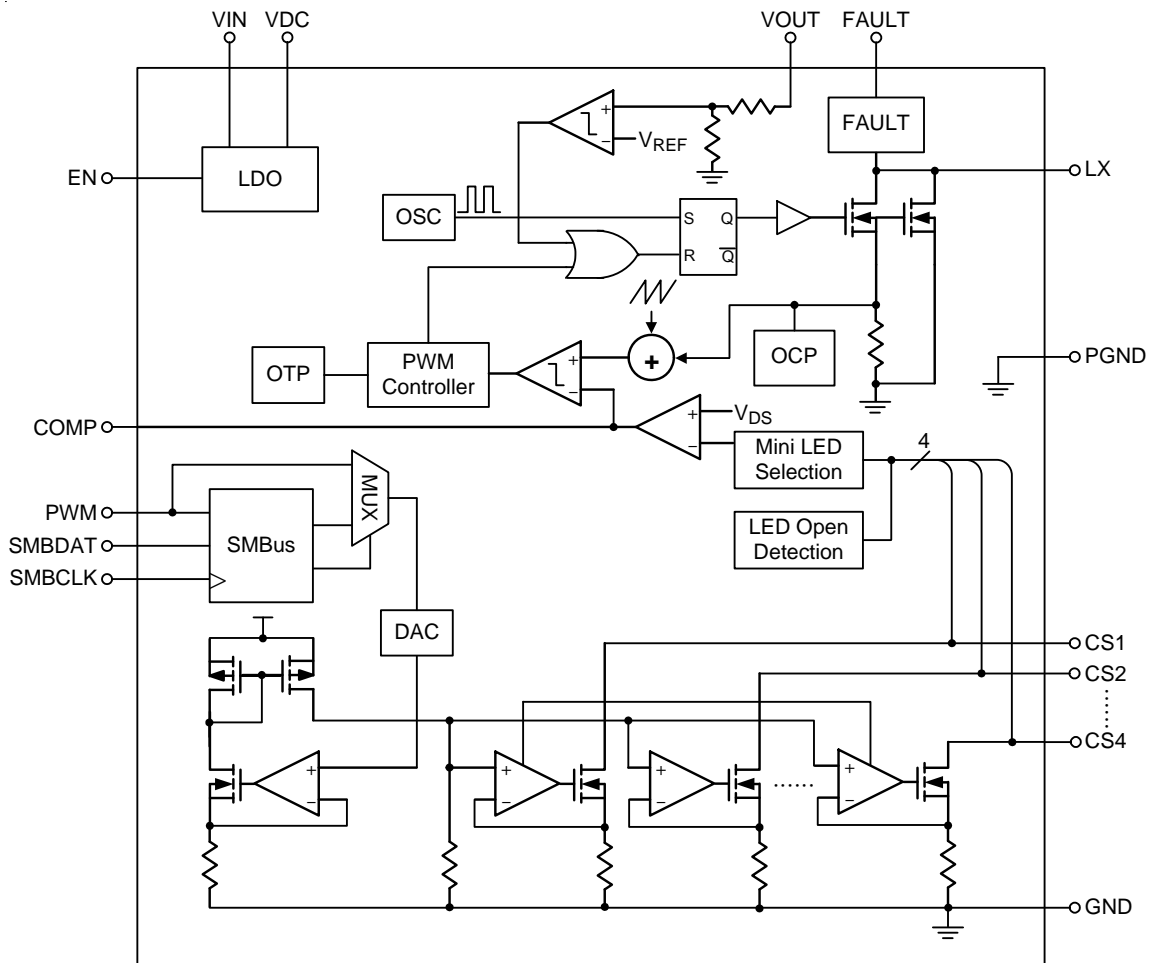

Operation

The RT8549L integrates four LED drivers and a Boost converter. When EN is High and VIN is higher than the UVLO for a white, the RT8549L will detect the status of the channel. Then the digital part will be reset and set all default states registers.

Once SMBus receives a "STOP" signal, the RT8549L will start to check PWM duty and then enter soft-start mode. The RT8549L will choose the minimum value of V_{LED} as the feedback voltage of Boost converter.

During operation, when a LED string is defined as short, the driver of that channel will be turned off. When LED string is defined as open, the driver of that channel will be turned off, and auto-recovery when the "OPEN" is released.

Once "VOUT shorted to GND" or "Schottky diode shorted" are defined as the fault condition, the RT8549L will alarm this condition through the fault flag of SMBus. The fault flag could also be cleared through the SMBus.

Absolute Maximum Ratings (Note 1)

- Supply Input Voltage, V_{IN} to GND ----- -0.3V to 44V
- VDC to GND ----- -0.3V to 6V
- SMBDAT, SMBCLK to GND ----- -0.3V to 26.5V
- EN, PWM, COMP, FAULT to GND ----- -0.3V to 44V
- CS1, CS2, CS3, CS4 to GND ----- -0.3V to 66V
- LX, VOUT to GND ----- -0.3V to 72V
- LX to GND (<100ns) ----- -2V to 72V
- Power Dissipation, P_D @ $T_A = 25^\circ\text{C}$
 - WDFN-16L 5x5 ----- 3.47W
- Package Thermal Resistance (Note 2)
 - WDFN-16L 5x5, θ_{JA} ----- 28.8°C/W
 - WDFN-16L 5x5, θ_{JC} ----- 4.4°C/W
- Lead Temperature (Soldering, 10 sec.) ----- 260°C
- Junction Temperature ----- 150°C
- Storage Temperature Range ----- -65°C to 150°C
- ESD Susceptibility (Note 3)
 - HBM (Human Body Model) ----- 2kV
 - MM (Machine Model) ----- 200V

Recommended Operating Conditions (Note 4)

- Supply Input Voltage ----- 4.2V to 24V
- Junction Temperature Range ----- -40°C to 125°C
- Ambient Temperature Range ----- -40°C to 85°C

Electrical Characteristics

($V_{IN} = 12\text{V}$, $C_{IN} = 1\mu\text{F}$, $T_A = 25^\circ\text{C}$, unless otherwise specified)

Parameter	Symbol	Test Conditions	Min	Typ	Max	Unit
Input Power Supply						
Input Supply Voltage	V_{IN}		4.2	--	24	V
Quiescent Current	I_Q	EN = 3.3V, PWM = 0	--	3.3	--	mA
Shutdown Current	I_{SHDN}	$V_{IN} = 4.5\text{V}$, EN = 0	--	--	10	μA
Under-Voltage Lockout Threshold	V_{UVLO}	V_{IN} rising	--	3.8	--	V
Under-Voltage Lockout Hysteresis	ΔV_{UVLO}		--	500	--	mV
Interface Characteristic						
EN, PWM, SMBCLK, SMBDAT Input High Threshold	V_{IH}		2	--	--	V
EN, PWM, SMBCLK, SMBDAT Input Low Threshold	V_{IL}		--	--	0.8	V
EN Internal Pull-Low Current	I_{IH_EN}	$V_{EN} = 3.3\text{V}$	--	--	10	μA
SMBCLK, SMBDAT Internal Pull-Low Current	I_{IH_SMB}	$V_{UP} = 3.3\text{V}$	--	0.01	1	μA
PWM Internal Pull Low Current	I_{IH_PWM}	$V_{PWM} = 3.3\text{V}$	--	--	15	μA

Parameter	Symbol	Test Conditions	Min	Typ	Max	Unit
SMBus Interface Timing (Note 5)						
SMBus Operating Frequency	f _{SMB}		10	--	100	kHz
Bus Free Time between Stop and Start Condition	t _{BUF}		4.7	--	--	μs
Hold Time after Start Condition	t _{HD_STA}	After this period, the first clock is generated	4	--	--	μs
Repeated Start Condition Setup Time	t _{SU_STA}		4.7	--	--	μs
Stop Condition Setup Time	t _{SU_STO}		4	--	--	μs
Data Hold Time	t _{HD_DAT}		300	--	--	ns
Data Setup Time	t _{SU_DAT}		250	--	--	ns
Detect Clock Low Timeout	t _{TIMEOUT}		25	--	35	ms
Clock Low Period	t _{LOW}		4.7	--	--	μs
Clock High Period	t _{HIGH}		4	--	50	μs
Slave Device Cumulative Clock Low Extend Time_Slave	t _{LOW_SEXT}		--	--	25	ms
Master Device Cumulative Clock Low Extend Time_Master	t _{LOW_MEXT}		--	--	10	ms
Fall Time of SMB DAT/CLK	t _{F_SMB}		--	--	300	ns
Rise Time of SMB DAT/CLK	t _{R_SMB}		--	--	1000	ns
Power On Reset of SMB	t _{SMB_POR}	Time in which a device must be operation after power on reset	--	3	500	ms
Boost Converter						
Switching Frequency Accuracy	f _{SW_ACC}	Boost operates at PWM mode, f _{SW} = 400kHz	-10	--	10	%
Default Switching Frequency	f _{SW}	Boost operates at PWM mode	--	400	--	kHz
Switching Frequency Setting Range	f _{SW_RG}	Boost operates at PWM mode	200	--	900	kHz
Step-up Maximum Duty Cycle	D _{MAX}		--	93	--	%
Boost Switch R _{DS(ON)}	R _{DS(ON)_BST}	V _{DC} = 5V, I _{SW_BST} = 100mA	--	0.18	0.5	Ω
Switching Current Limitation	I _{OC_P_BST}		2.8	3.3	--	A
Over-Voltage Protection	V _{OUT}	OVP selection = B10	--	60	--	V
LED Current						
Leakage Current of CS _x	I _{LK_CSx}	V _{CSx} = 50V, I _{CS} = 0mA	--	--	10	μA
Minimum CS _x Regulation Voltage	V _{CS_MIN}	I _{CSx} = 120mA	--	0.45	--	V
Maximum LED Current Setting	I _{CS_MAX}		--	--	180	mA
Dimming Frequency	f _{PWM}		200	--	1000	Hz

Parameter	Symbol	Test Conditions	Min	Typ	Max	Unit
LED Current Accuracy	I _{CS_ACC}	PWM duty = 100%, I _{LED} = 120mA	-3	--	3	%
LED Current Matching	I _{LED_MAT}	PWM duty = 100%, I _{LED} = 120mA	-2	--	2	%
CSx Channel Unused Threshold	V _{CS_UNUSE}		--	0.2	--	V
Light Bar Open Threshold	V _{CS_OPEN}		--	0.1	--	V
Light Bar Short Threshold	V _{CS_SHORT}		--	5.6	--	V
Thermal Shutdown Temperature	T _{OTP}		--	150	--	°C
Thermal Shutdown Hysteresis	T _{OTP_hys}		--	20	--	°C
Mixed Mode Dimming Frequency	f _{PWM_LED}	When dimming duty < 25%	--	26	--	kHz

Note 1. Stresses beyond those listed under “Absolute Maximum Ratings” may cause permanent damage to the device. These are stress ratings only, and functional operation of the device at these or any other conditions beyond those indicated in the operational sections of the specifications is not implied. Exposure to absolute maximum rating conditions may affect device reliability.

Note 2. θ_{JA} is measured under natural convection (still air) at $T_A = 25^\circ\text{C}$ with the component mounted on a high effective-thermal-conductivity four-layer test board on a JEDEC 51-7 thermal measurement standard. θ_{JC} is measured at the exposed pad of the package.

Note 3. Devices are ESD sensitive. Handling precaution is recommended.

Note 4. The device is not guaranteed to function outside its operating conditions.

Note 5. Guaranteed by design; not subject to production testing.

Typical Application Circuit

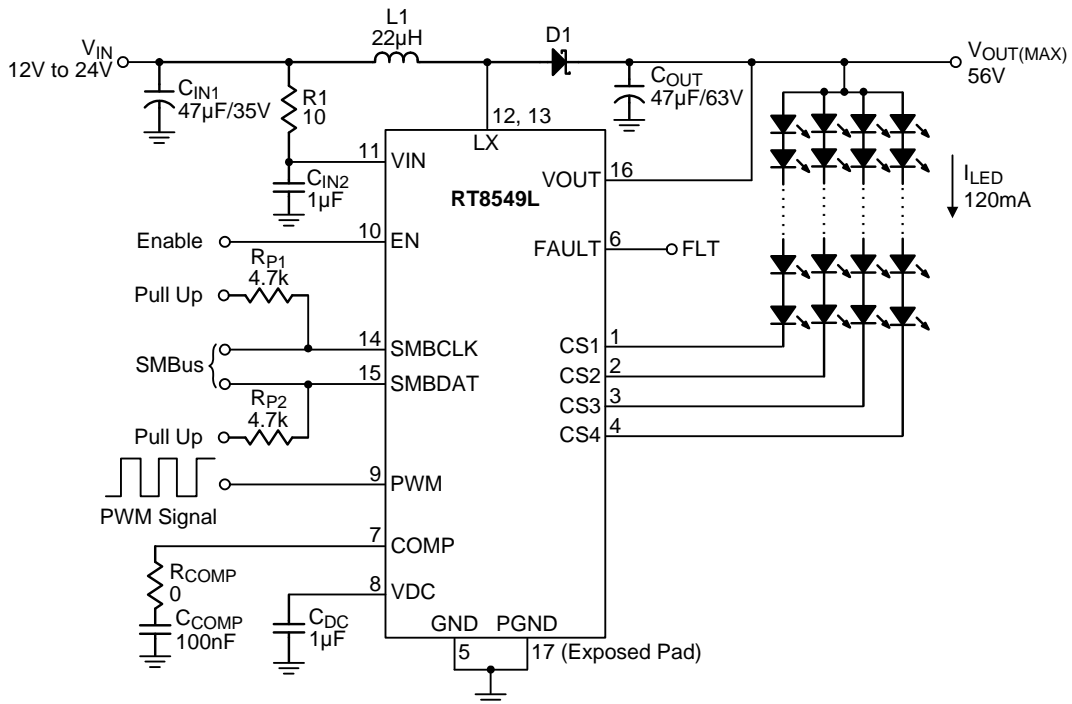

Figure 1. General Application

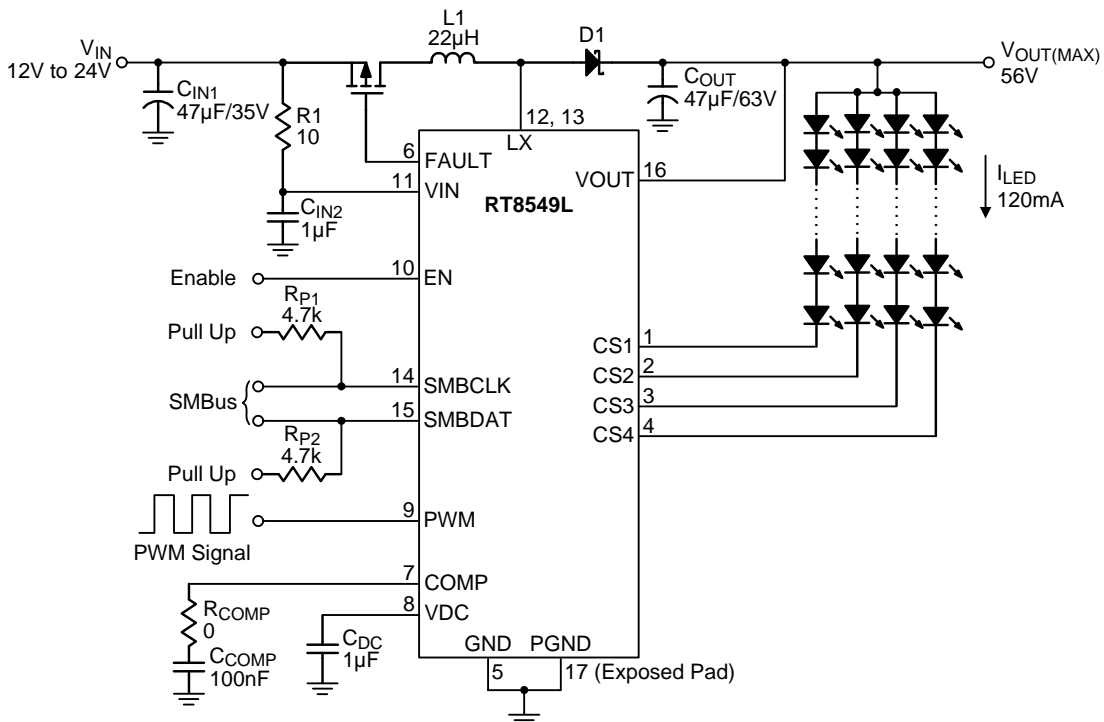
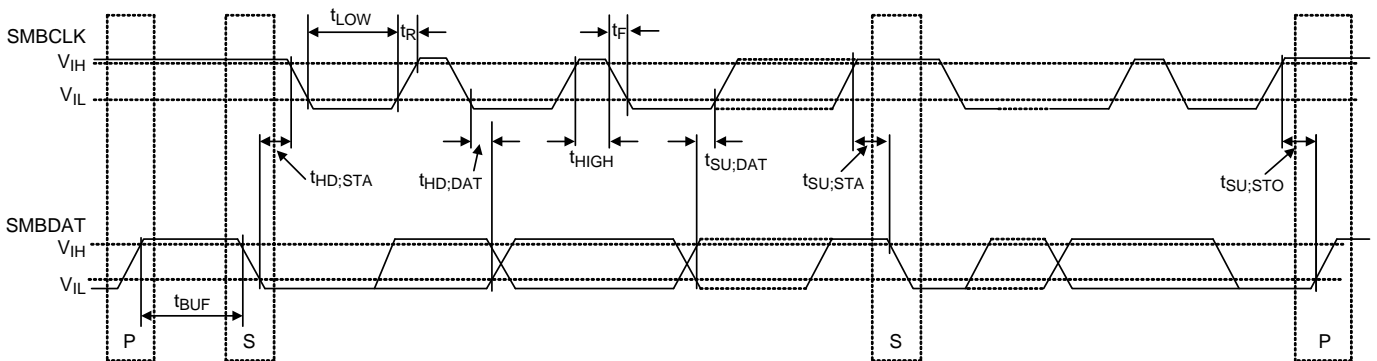

Figure 2. External P-MOSFET Isolation Application

Timing Diagram

SMBus Common AC Specification



SMBus Timeout

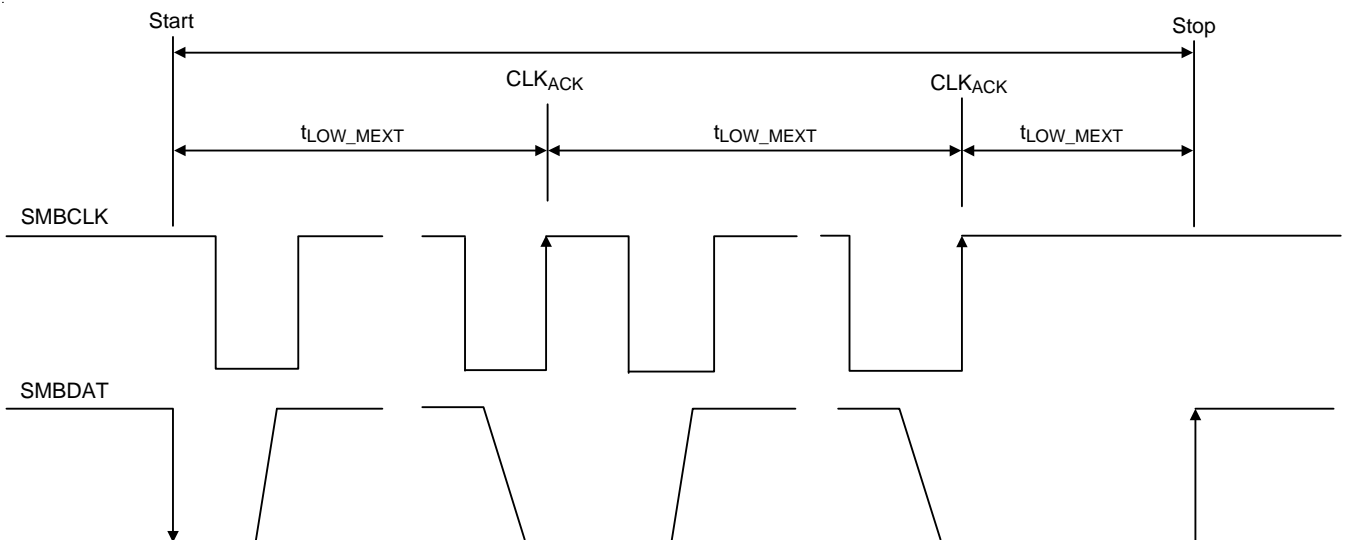

Power-On Sequence

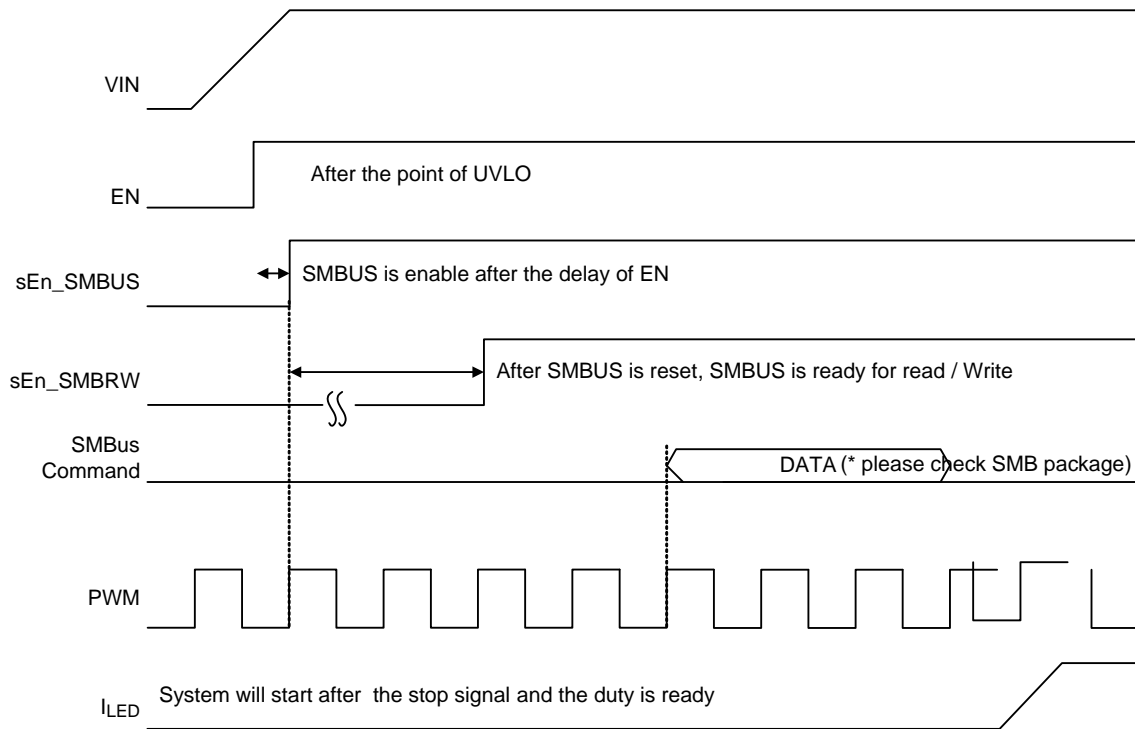

Power-Off Sequence

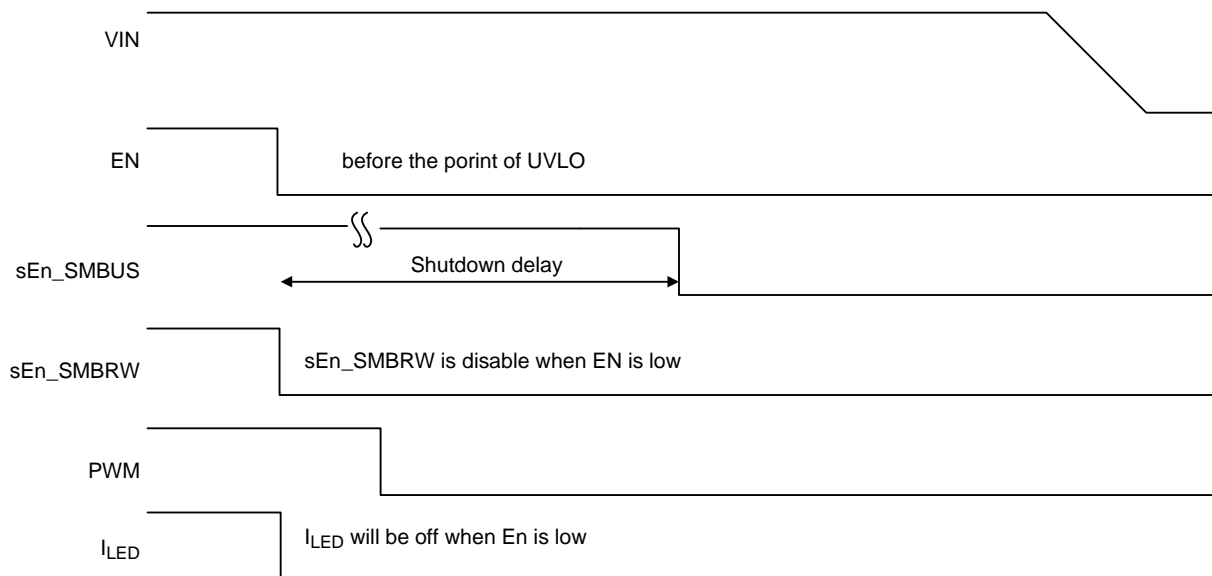

Typical Operating Characteristics

Efficiency vs. Input Voltage

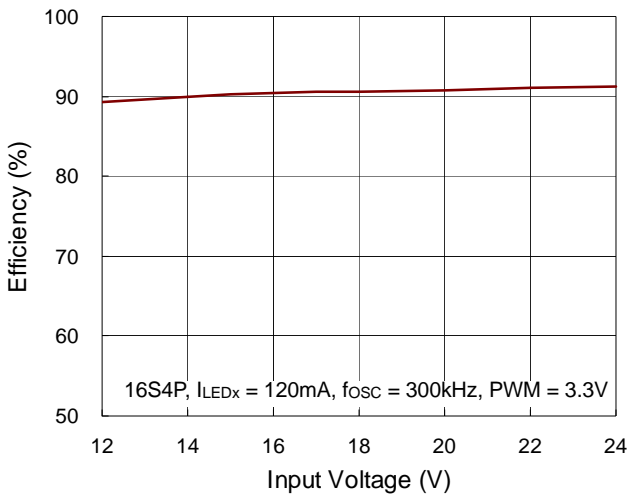

Efficiency vs. Input Voltage

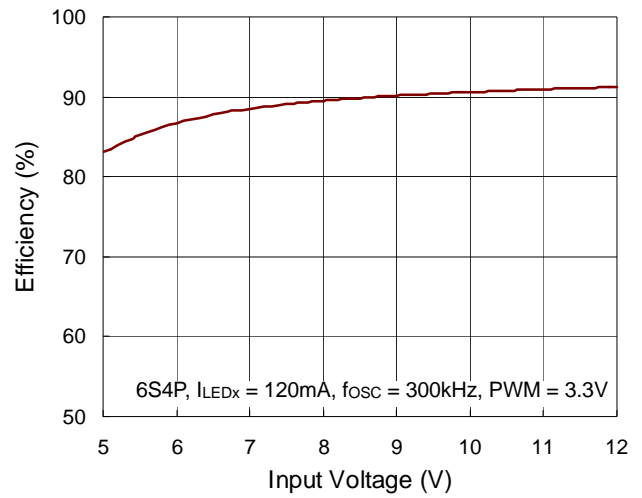

LED Current vs. Input Voltage

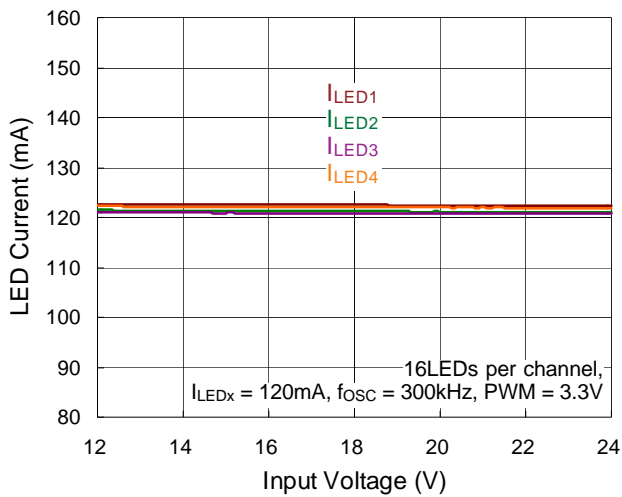

LED Current vs. Input Voltage

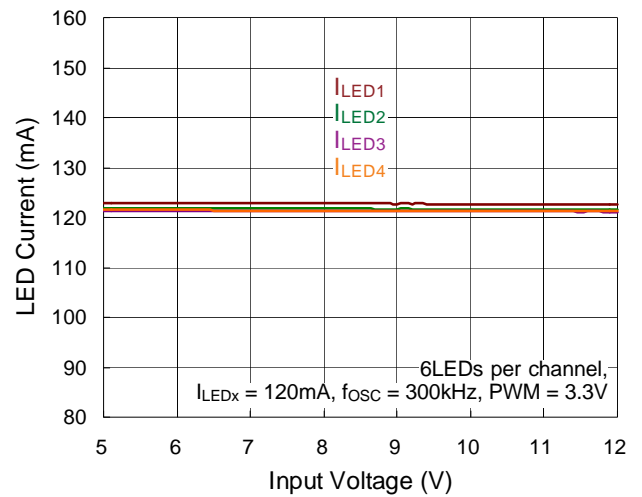

LED Current vs. Temperature

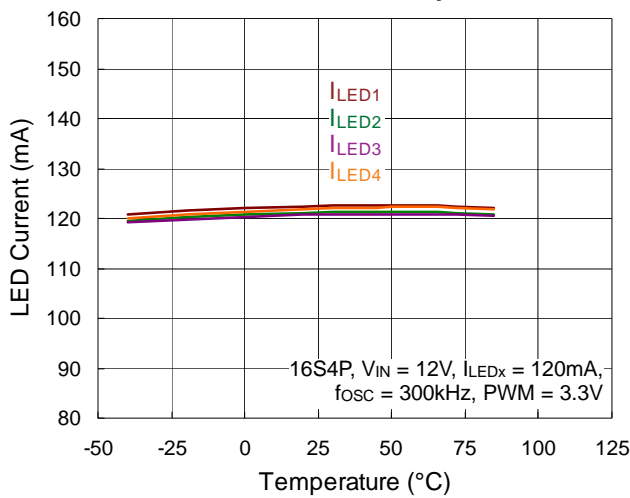

LED Current vs. External Dimming Duty

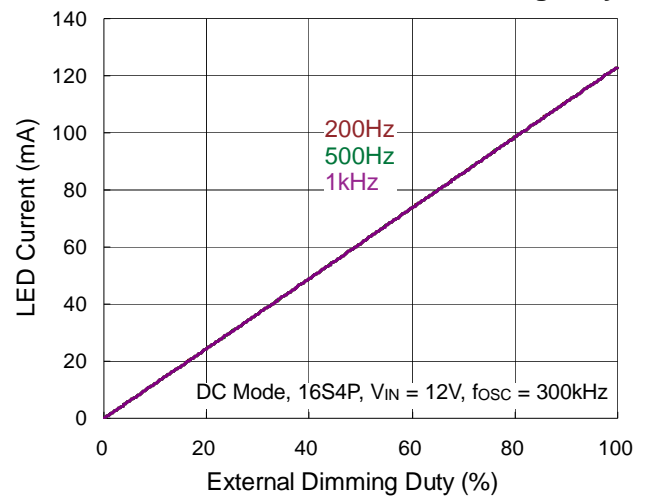

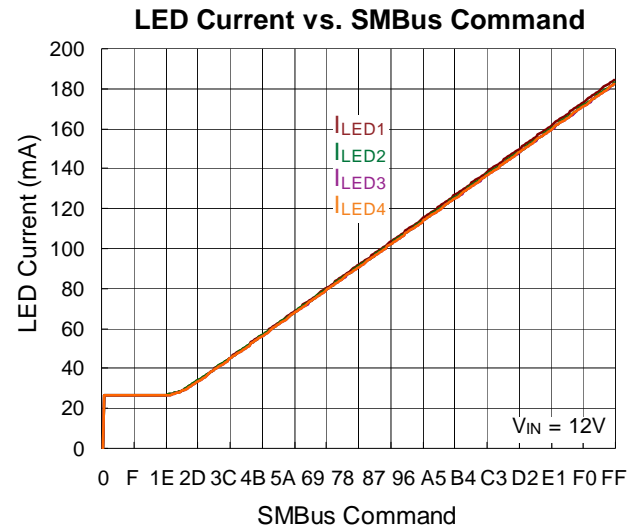
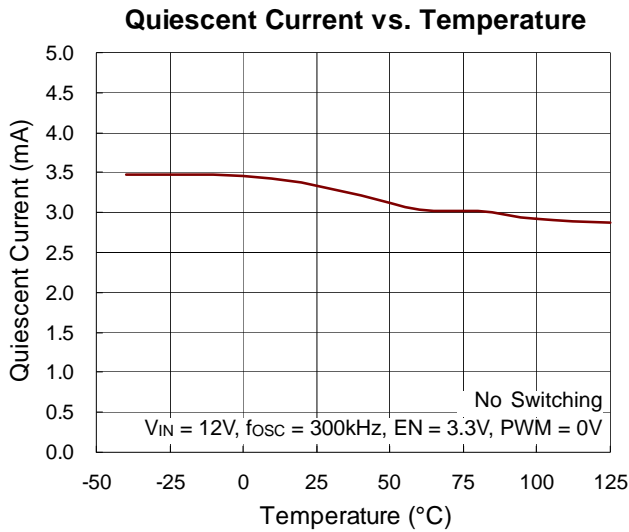
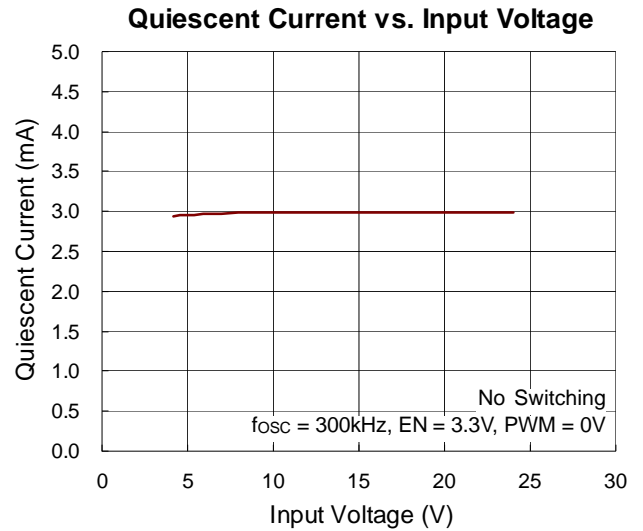
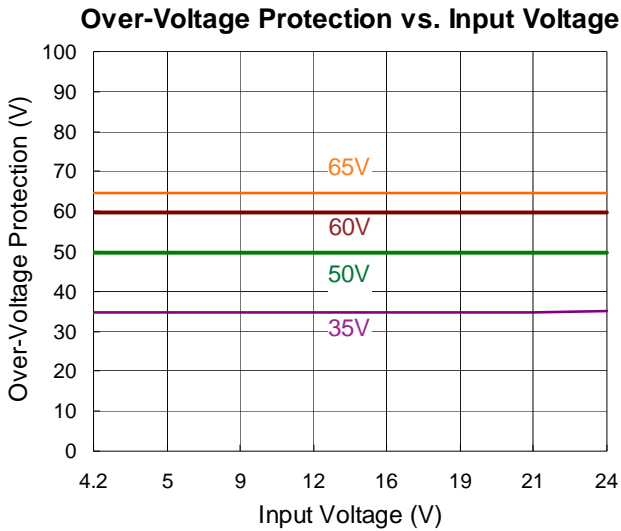
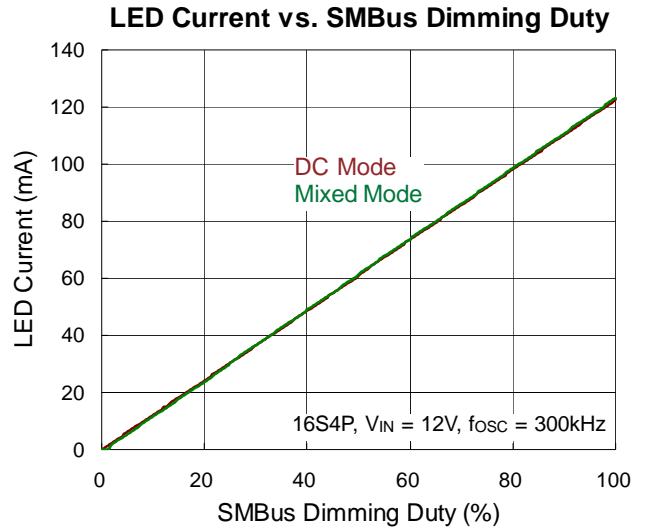
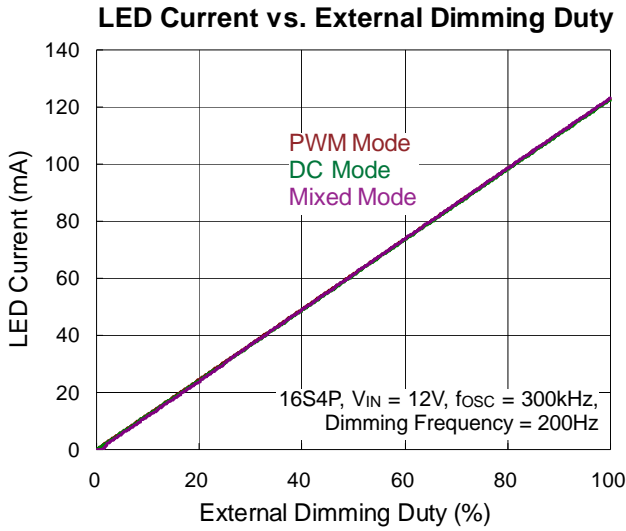

VDC vs. Temperature

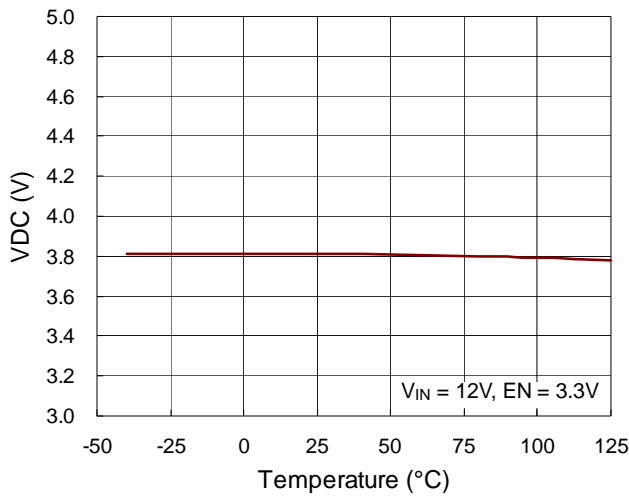

Line Transient Response

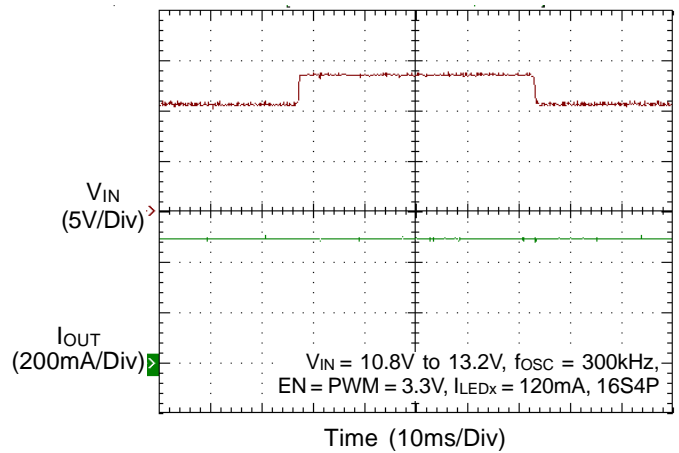

Power On from SMBus Command

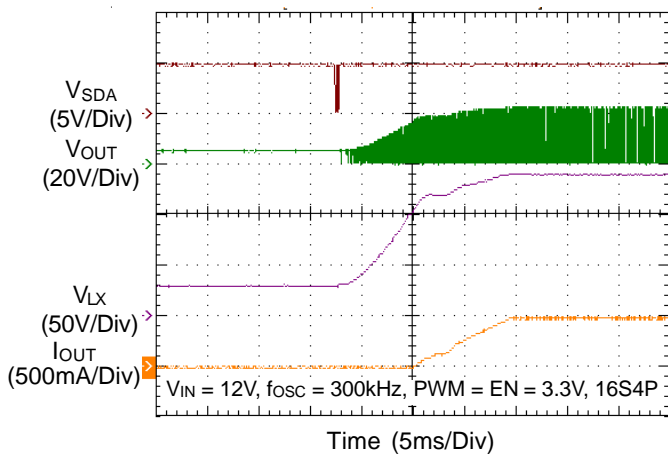

Power Off from EN

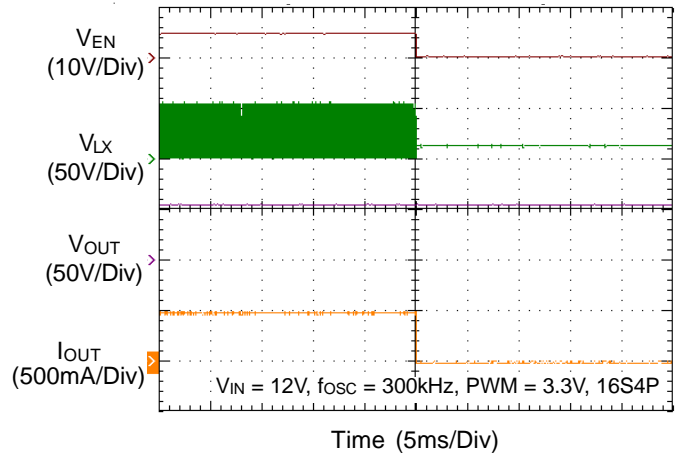

Power On from PWM

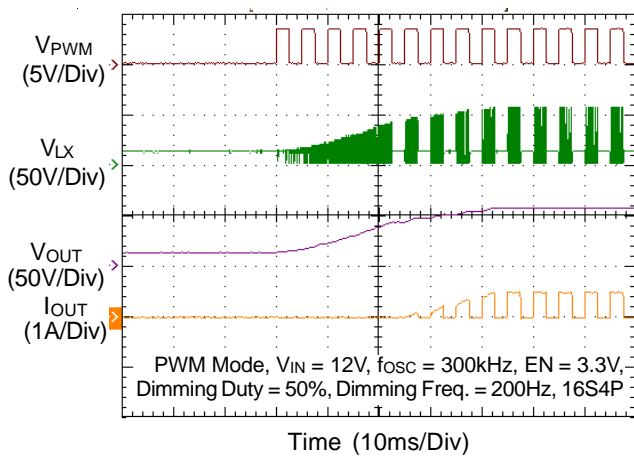

Power Off from PWM

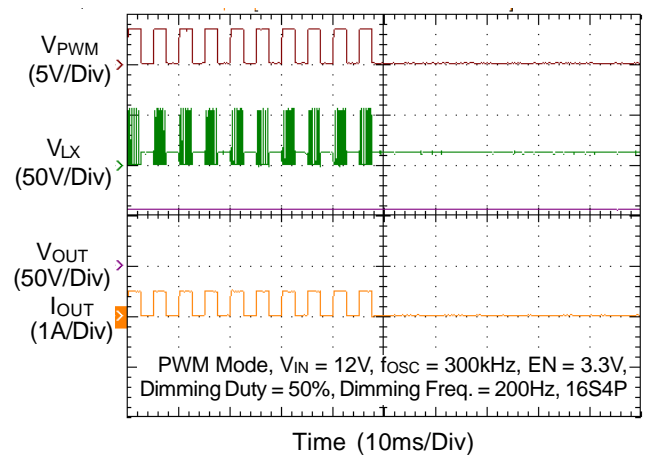

Application Information

The RT8549L is a general purpose 4-CH LED driver and is capable of delivering a maximum 180mA LED current. The IC is a current-mode Boost converter integrated with a 60V/3.3A power switch and can cover a wide VIN range from 4.2V to 24V. The part integrates both built-in soft-start and with PWM dimming control; moreover, it provides over voltage, over-temperature and current limit protections. It also integrates PWM and mixed mode dimming function for accurate LED current control. The PWM dimming frequency can operate from 200Hz to 1kHz without inducing any inrush current in LED and inductor.

Dimming Control

The RT8549L provides three dimming modes for controlling the LED brightness. The three dimming modes include PWM mode, DC mode and Mixed mode, and the dimming mode could be set by register 00h. If the 00h[1:0] is set 11, the dimming mode is still in Mixed mode which is shown in Table 2 below.

PWM Mode

The ON/OFF of the current source is synchronized to the PWM signal. The frequency of LED current is equal to the PWM input signal.

DC Mode

The PWM signal will be monitored and calculate its duty. The magnitude of I_{LED} will be proportional to the duty.

$$I_{LED} = I_{MAX} \times \text{duty}$$

Mixed Mode

When 25% ≤ PWM duty ≤ 100%, the PWM duty modulated the amplitude of the current. (same as DC mode)

PWM duty < 25%, the DC dimming will translate to PWM dimming, controlling the PWM duty instead by amplitude.

Table 1. Register Map

Slave Address : b0110001									
Register Address	bit7	bit6	bit5	bit4	bit3	bit2	bit1	bit0	Default Value
0x00	OVP Reset [7]			OCP Fault [4]		DIM_sig_Sel [2]	Dimming Control [1:0]		0x01
0x01		OVP [6:5]		Current_Limit [4]	Switching_frequency [3:0]				0x54
0x02	LED Current Setting [7:0]								0x00
0x03	Fault Enable [7]				Fault Flag Clear [3]	SLP [2]	SLP Latch [1]	Fault Flag [0]	0x80
0x04	SMBus Dimming Control [7:0]								0x00
0x06	Written Check [7]	Vendor ID							0x80

Table 2. Dimming Control Mode Selection

Address	Bit	Name	Default Value	Description	R/W
00h	[1:0]	Dimming mode selection	DC mode (01)	00 : PWM mode	R/W
				01 : DC mode	
				10 : Mixed mode	

Dimming Control Signal Selection

The RT8549L integrates a dimming control signal selection. The dimming control signal source could be set by the second bit of register 00h. If the bit equals to 0, it means the dimming control signal source just depends

on the input signal of the PWM pin. Otherwise, if the bit equals to 1, the dimming control signal is controlled by the command of register 04h. The dimming control signal of register 04h supports the DC mode and Mixed mode. The option is shown in Table 3 below.

Table 3. Dimming Control Signal Selection

Address	Bit	Name	Default Value	Description	R/W
00h	[2]	Dimming Control Signal Selection	PWM pin (0)	0 : Dimming control signal is depend on PWM pin.	R/W
				1 : Dimming control signal supply by register 04h.	

Note : There is no two cycle delay when the bit set to 1.

OCP Fault

There is an over-current protection function cycle-by-cycle to turn off the power MOSFET of the Boost converter. We could have a further protection if the OCP Fault function is enabled (addr 0x00h, bit 4). Once this register is set high, internal counter is started to check OCP status. if OCP occurs 128 times continuously, the fault pin will be pulled high to turned off the external P-MOSFET.

The OCP Fault Could be Selection as the Table 4.

Switching Frequency

The LED driver switching frequency is adjusted by the SMBus, The switching frequency setting range and resolutions are shown in the Table 6 below.

If the switching frequency command is below to 0x02h (0x01h to 0x00h), the switching frequency would be clamped at 200kHz. The command is above the 0x09h (0x0A to 0x0F), the switching frequency would be clamped at 900kHz.

OVP Reset

The RT8549L integrates an OVP Reset mechanism. User could choose to let the IC Reset or output voltage clamped on a voltage of OVP. The OVP Reset mechanism is setting by SMBus interface, and set the bit [7] of register 00h.

Table 4. OCP Fault Setting

Address	Bit	Name	Default Value	Description	R/W
00h	[4]	OCP Fault	Disable (0)	0 : Disable	R/W
				1 : Enable	

Table 5. OVP Reset Setting

Address	Bit	Name	Default Value	Description	R/W
00h	[7]	OVP Reset	Disable (0)	0 : Disable	R/W
				1 : Enable	

Table 6. Switching Frequency Setting

Address	Bit	Name	Default Value	Description	Resolution	R/W
01h	[3:0]	Boost switching frequency	400kHz (0x04h)	0x04h : 400kHz	~100kHz (0x02h to 0x09h)	R/W
				Between the code 0x00h and 0x02h are equal to 200kHz.		
				Between the code 0x09h and 0x0Fh are equal to 900kHz.		

Current Limit Protection

The RT8549L integrates current limit protection, and the current of current limit protection could be set by SMBus, which is shown in the Table 7 below.

The RT8549L can limit the peak current to achieve over-current protection. The RT8549L senses the inductor current during the “ON” period that flows through the LX pin. The duty cycle depends on the current signal and internal slope compensation in comparison with the error signal. The internal switch of Boost converter will be turned off when the peak current value of inductor current is larger than the over-current protection setting. In the “OFF” period, the inductor current will be decreased until the internal switch is turned on by the oscillator.

Over-Voltage Protection

The RT8549L integrates over-voltage protection. The over-voltage protection could be set by the SMBus, the voltage of over-voltage protection (V_{OVP}) could be selected as the Table 8 below.

When the Boost output voltage rises above the V_{OVP} , the internal switch will be turned off. Once the Boost output voltage drop below the V_{OVP} , the internal switch will be turned on again. The Boost output voltage can be clamped at the V_{OVP} .

Table 7. Current Limit Protection Setting

Address	Bit	Name	Default Value	Description	R/W
01h	[4]	Switching current limitation selection	3.3A (1)	Boost switch current limitation.	R/W
				0 : 2.2A	
				1 : 3.3A	

Table 8. OVP Voltage Setting

Address	Bit	Name	Default Value	Description	R/W
01h	[6:5]	Over voltage protection selection	65V (11)	Boost output over voltage protection.	R/W
				11 : 65V	
				10 : 60V	
				01 : 50V	
				00 : 35V	

LED Current Setting

The LED current of each channel could be set by SMBus command, it is shown in the Table 9.

When the LED current setting command is below 0x20h to 0x01h, the LED current will be kept at 22.58mA. When the command is 0x00h, the LED current will be set to 0mA. The maximum LED current setting is 180mA. The one step of LED current is approximately 0.706mA.

Fault Protection

The fault protection function can protect the system once there is an abnormal state at switching pin. (eg. too low during turn off and too high during turn on) the FAULT pin will output a voltage level same with VIN, forcing the P-MOSFET to be turned off, to prevent the short current to damage IC or components. When under normal operation, the FAULT pin output voltage will be clamp at 6V making sure the P-MOSFET can be fully turn on.

In addition, this function could be chosen enable or disable by SMBus command, setting the bit [7] of register 03h. If the bit data is written 1, it means enable fault protection, and vice versa.

When the protection enable, and the one of two fault condition is happened. To read fault flag bit [0] of register 03h, it would be from 0 changed to 1. After the fault condition is cleared, user could set fault flag clear bit [3] of register 03h to 1 and write it.

When IC is enable, "FAULT" will be clamped VIN - 6V, such that LX and VOUT will be equal to VIN though the P-MOSFET.

And the detection LX short function will be active 500μs later. Once V(LX) < 2.4V, IC will define abnormal condition caused, and V(FAULT) will be pulled to VIN in order turn off the P-MOSFET.

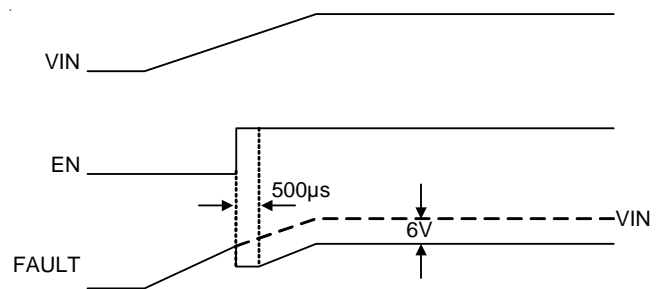

Table 9. LED Current Setting

Address	Bit	Name	Default Value	Description	Resolution	R/W
02h	[7:0]	LED current setting	0mA (0x00h)	control the max current	~0.706mA (0xFFh to 0x20h)	R/W
				0xFFh : 180mA		
				0x20h : 22.58mA		
				0x00h : 0mA		
				Between the code 0x01h and 0x20h are equal to 22.58mA		

Table 10. Fault Protection Setting

Address	Bit	Name	Default Value	Description	R/W
03h	[0]	Monitor fault condition	--	Detect fault condition happen or not (Read only).	R
	[3]	Fault flag could be cleared by SMBus.	Original State (0)	0 : keep the original state 1 : clear fault flag	R/W
	[7]	Fault function enable.	Enable (1)	0 : disable 1 : enable	R/W

Short LED Protection

The RT8549L integrates Short LED Protection (SLP). If CSx pin voltages exceeds the threshold of approximately 5.6V during normal operation, the channels will be turned off. And the channel will keep rechecking in the rest mode.

User could turn on or turn off the SLP function by SMBus interface. If the bit [2] of register 03h write 1, its means the SLP function is turn off. On the contrary, the bit is written 0 means turn it on. The register setting is shown in Table 11 below.

User could choose latch mode of SLP by setting. Once the SLP occurs, the particular channel will be off.

SMBus Dimming

The RT8549L integrates an SMBus dimming control signal by register 04h. The dimming duty is adjusted from 0% (0x00) to 100% (0xFF), and one step is about 0.392%. Users just need to write the register 04h. ex. Register 04h write into 0x7F, the register code is corresponds to 50% dimming duty. The setting method is shown Table 12 below.

The internal SMBus signal supports only DC mode and Mixed mode. The dimming frequency is about 26kHz when the dimming duty below to 25% of Mixed mode.

LED Current Written Check

The RT8549L provides a check bit, it is for users to check LED current greater than zero. If LED current setting is greater than zero, the check bit would be changed to 0. Otherwise, LED current setting equals to zero, and the check bit would be changed to 1. The check bit is shown in Table 13 below.

Table 11. Short LED Protection Setting

Address	Bit	Name	Default Value	Description	R/W
03h	[1]	Short LED protection latch	Reset Mode(0)	0 : Reset Mode 1 : Latch Mode	R/W
	[2]	Short LED protection	Enable (0)	0 : Enable 1 : Disable	R/W

Table 12. SMBus Dimming Control Setting

Address	Bit	Name	Default Value	Description	Resolution	R/W
04h	[7:0]	SMBus Dimming Control	0% (0x00)	0x00 : 0% 0xFF : 100%	0.392%	R/W

Table 13. LED Current Check Bit

Address	Bit	Name	Default Value	Description	R/W
06h	[7]	Written Check	LED Current = 0 (1)	0 : LED Current Setting > 0 1 : LED Current Setting = 0	R

Table 14. Vendor ID

Address	Bit	Name	Default Value	Description	R/W
06h	[6:4]	Vendor ID	000	Vendor Identification : Richtek : 000	R

SMBus Write Timing Sequence

Write 1 byte

(Command byte is sent after the address and determines which register receives the data that follows the command byte.)

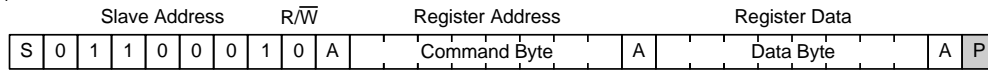

Write N bytes

(Command byte is sent after the address and determines which register receives the data that follows the command byte.)

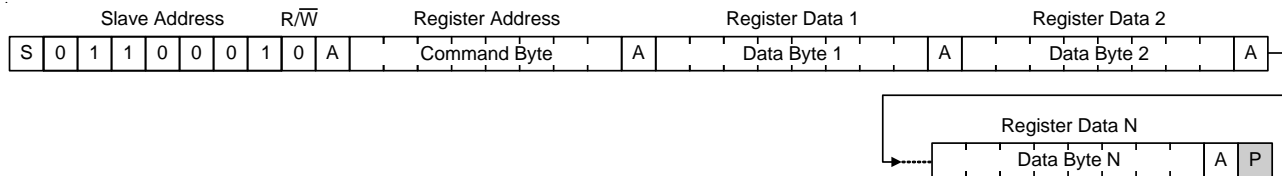

SMBus Read Timing Sequence

Read 1 byte

(Command byte is sent after the address and determines which register is accessed. After a start, the device address is sent again and LSB is set to logic 1. Data defined by command byte then is sent by RT8549L.)

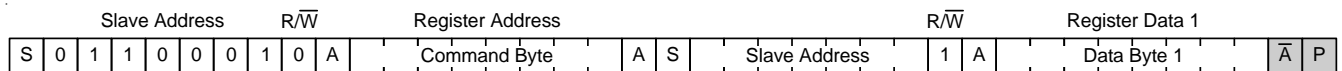

Read N bytes

(Command byte is sent after the address and determines which register is accessed. After a start, the device address is sent again and LSB is set to logic 1. Data defined by command byte then is sent by RT8549L.)

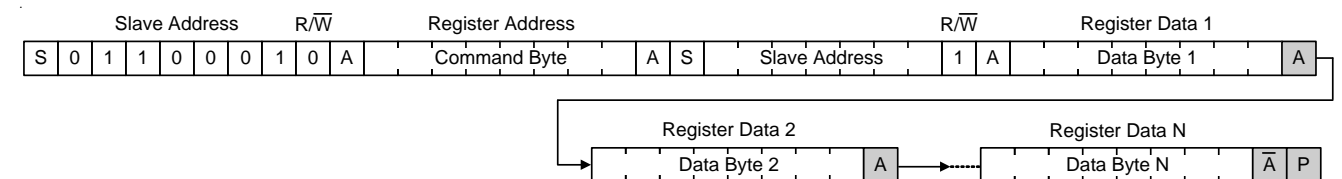

LED Connection

The RT8549L equips 4-CH LED drivers and each channel supports up to 17 LEDs ($V_f = 3V$). The LED strings are connected from the output of the Boost converter to the CSx (x = 1 to 4) pins respectively. If one of the current sink channels is not used, the CSx pin should be connected to GND. If the un-used channel is not connected to GND, it will be considered that the LED string is opened, the channel will turn light when the LED string is recovering connected.

Compensation

The regulator loop can be compensated by adjusting the external components connected to the COMP pin. The COMP pin is the output of the internal error amplifier. The compensation capacitor will adjust the integrator zero to maintain stability and the resistor value will adjust the frequency integrator gain for fast transient response. Typical values of the compensation components are $R_{COMP} = 0\Omega$, $C_{COMP} = 100nF$.

Over Temperature Protection

The RT8549L has over temperature protection function to prevent the IC from overheating due to excessive power dissipation. The OTP function will shutdown the IC when junction temperature exceeds $150^\circ C$ (typ.). When junction temperature cools down to $130^\circ C$ ($T_{OTP_hys} = 20^\circ C$), the LED driver will return to normal work.

Series Resistor Selection On PWM Pin

The calculation of series resistor should consider the Input high threshold (V_{IH}) and the internal pull-low current (I_{IH_PWM}) of PWM. The minimum value of V_{IH} is 2V, and the maximum of I_{IH_PWM} is $15\mu A$. The resistor could be calculated by the equation below. Ex. $V_{PWM} = 3.3V$, the R_{PWM} must be smaller than $86.67k\Omega$.

$$R_{PWM} < \frac{V_{PWM} - 2V}{15\mu A}$$

Where V_{PWM} is the high level of PWM dimming signal.

Series Resistor Selection On EN Pin

The calculation of series resistor should consider the Input high threshold (V_{IH}) and the internal pull-low current (I_{IH_EN}) of EN. The minimum value of V_{IH} is 2V, and the maximum of I_{IH_EN} is $10\mu A$. The resistor could be calculated by the equation below. Ex. $V_{EN} = 3.3V$, the R_{EN} must be smaller than $130k\Omega$.

$$R_{EN} < \frac{V_{EN} - 2V}{10\mu A}$$

Where V_{EN} is the high level of EN signal.

Inductor Selection

The value of the inductance, L, can be approximated by the following equation, where the transition is from Discontinuous Conduction Mode (DCM) to Continuous Conduction Mode (CCM) :

$$L = \frac{D \times (1-D)^2 \times V_{OUT}}{2 \times f_{OSC} \times I_{OUT}}$$

The duty cycle, D, can be calculated as the following equation :

$$D = \frac{V_{OUT} - V_{IN}}{V_{OUT}}$$

where V_{OUT} is the maximum output voltage, V_{IN} is the minimum input voltage, f_{OSC} is the operating frequency, and I_{OUT} is the sum of current from all LED strings. The Boost converter operates in DCM over the entire input voltage range when the inductor value is less than this value, L. With an inductance greater than L, the converter operates in CCM at the minimum input voltage and may be discontinuous at higher voltages.

The inductor must be selected with a saturated current rating that is greater than the peak current as provided by the following equation :

$$I_{PEAK} = \frac{V_{OUT} \times I_{OUT}}{\eta \times V_{IN}} + \frac{V_{IN} \times D \times T_{OSC}}{2 \times L}$$

where η is the efficiency of the power converter.

Diode Selection

Schottky diodes are recommended for most applications because of their fast recovery time and low forward voltage. Power dissipation, reverse voltage rating, and pulsating peak current are important parameters for consideration when making a Schottky diode selection. Make sure that the diode's peak current rating exceeds I_{PEAK} and reverse voltage rating exceeds the maximum output voltage.

Supply Voltage Capacitor Selection

The RT8549L equips a built-in LDO linear regulator to provide the internal logic of IC power. The output of LDO is the pin out of VDC. The VDC pin is recommended to connect at least a $1\mu\text{F}/25\text{V}$ bypass capacitor. The bypass capacitor should be X5R or X7R type to assure the bypass capacitance remains stable in over-voltage or over-temperature.

Input Capacitor Selection

The ceramic capacitors are recommended for input capacitor applications. Low ESR will effectively reduce the input voltage ripple caused by switching operation. Two $10\mu\text{F}/25\text{V}$ capacitors are sufficient for most applications. Nevertheless, this value can be decreased for lower output current requirement. Another consideration is the voltage rating of the input capacitor must be greater than the maximum input voltage.

Output Capacitor Selection

Output ripple voltage is an important index for estimating the performance. This portion consists of two parts, one is the ESR voltage of output capacitor, another part is formed by charging and discharging process of output capacitor. Refer to Figure 3, evaluate ΔV_{OUT1} by ideal energy equalization. According to the definition of Q, the Q value can be calculated as the following equation :

$$Q = \frac{1}{2} \times \left[\left(I_{IN} + \frac{1}{2} \Delta I_L - I_{OUT} \right) + \left(I_{IN} - \frac{1}{2} \Delta I_L - I_{OUT} \right) \right] \times \frac{V_{IN}}{V_{OUT}} \times \frac{1}{f_{OSC}} = C_{OUT} \times \Delta V_{OUT1}$$

where f_{OSC} is the switching frequency, and ΔI_L is the inductor ripple current. Move C_{OUT} to the left side to estimate the value of ΔV_{OUT1} as the following equation :

$$\Delta V_{OUT1} = \frac{D \times I_{OUT}}{\eta \times C_{OUT} \times f_{OSC}}$$

Then, take the ESR into consideration, the ESR voltage can be determined as the following equation :

$$\Delta V_{ESR} = \left(\frac{I_{OUT}}{1-D} + \frac{V_{IN} \times D \times T_{OSC}}{2L} \right) \times R_{ESR}$$

Finally, the total output ripple ΔV_{OUT} is combined from the ΔV_{OUT1} and ΔV_{ESR} . In the general application, the output capacitor is recommended to use a $47\mu\text{F}/63\text{V}$ electrolytic capacitor.

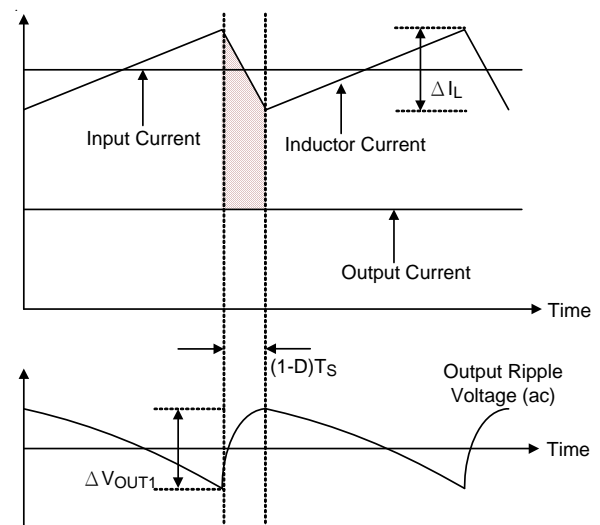

Figure 3. The Output Ripple Voltage Without the Contribution of ESR

Thermal Considerations

The junction temperature should never exceed the absolute maximum junction temperature $T_{J(MAX)}$, listed under Absolute Maximum Ratings, to avoid permanent damage to the device. The maximum allowable power dissipation depends on the thermal resistance of the IC package, the PCB layout, the rate of surrounding airflow, and the difference between the junction and ambient temperatures. The maximum power dissipation can be calculated using the following formula :

$$P_{D(MAX)} = (T_{J(MAX)} - T_A) / \theta_{JA}$$

where $T_{J(MAX)}$ is the maximum junction temperature, T_A is the ambient temperature, and θ_{JA} is the junction-to-ambient thermal resistance.

For continuous operation, the maximum operating junction temperature indicated under Recommended Operating Conditions is 125°C. The junction-to-ambient thermal resistance, θ_{JA} , is highly package dependent. For a WDFN-16L 5x5, the thermal resistance, θ_{JA} , is 28.8°C/W on a standard JEDEC 51-7 high effective-thermal-conductivity four-layer test board. The maximum power dissipation at $T_A = 25^\circ\text{C}$ can be calculated as below :

$$P_{D(MAX)} = (125^\circ\text{C} - 25^\circ\text{C}) / (28.8^\circ\text{C/W}) = 3.47\text{W for a WDFN-16L 5x5 package.}$$

The maximum power dissipation depends on the operating ambient temperature for the fixed $T_{J(MAX)}$ and the thermal resistance, θ_{JA} . The derating curves in Figure 4 allows the designer to see the effect of rising ambient temperature on the maximum power dissipation.

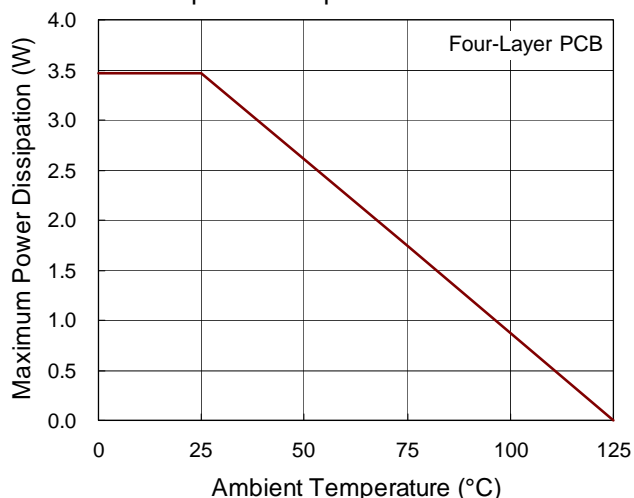

Figure 4. Derating Curve of Maximum Power Dissipation

Layout Consideration

PCB layout is very important for designing switching power converter circuits. The following layout guides should be strictly followed for best performance of the RT8549L.

- ▶ The power components, L1, D1, C_{IN1} and C_{OUT} must be placed as close as possible to reduce power loop. The PCB trace between power components must be as short and wide as possible.
- ▶ Place L1 and D1 as close as possible to LX pin. The trace should be as short and wide as possible. Keep the LX node away from the COMP, VDC, SMBDAT and SMBCLK ground.
- ▶ The compensation circuit (R_{COMP} , C_{COMP}) should be kept away from the power loops and should be shielded with a ground trace to prevent any noise coupling. Place the compensation components as close as possible to the COMP pin.
- ▶ The exposed pad of the chip should be connected to a large ground plane for thermal consideration.

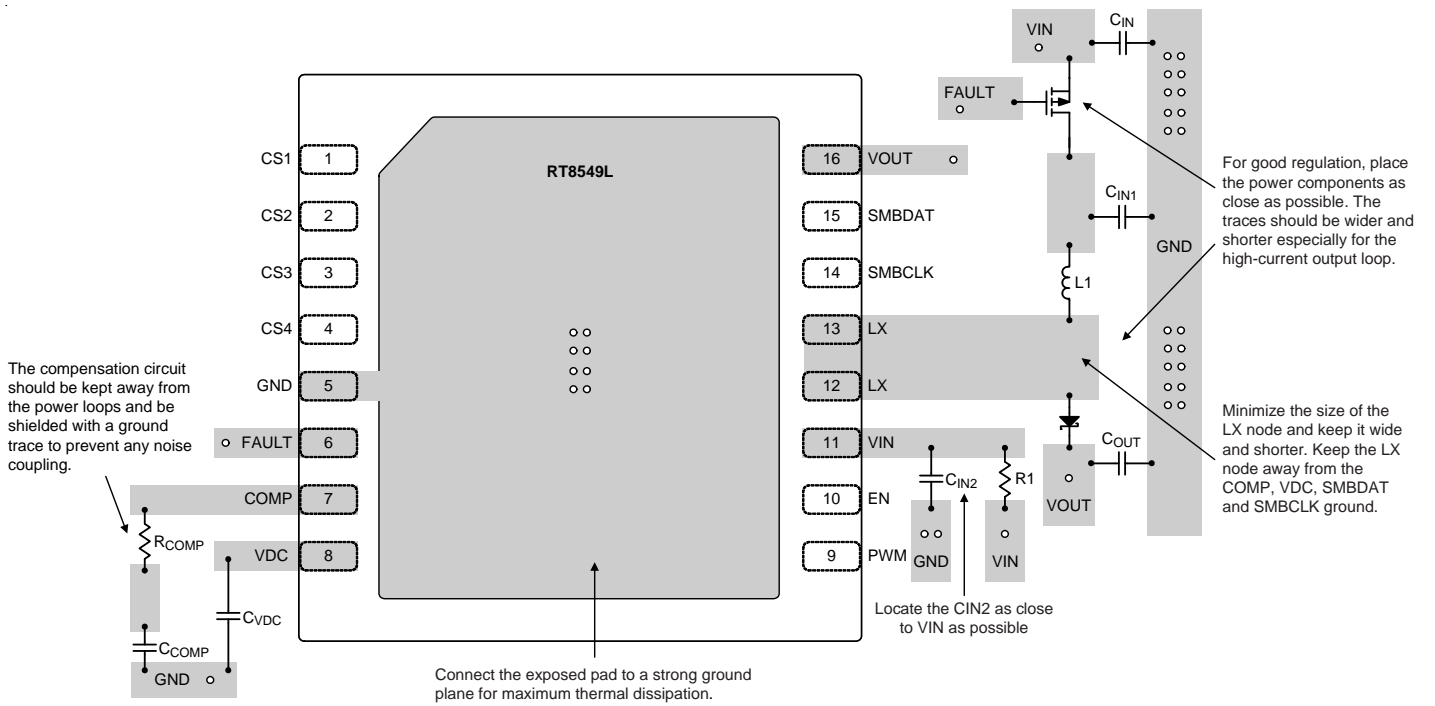
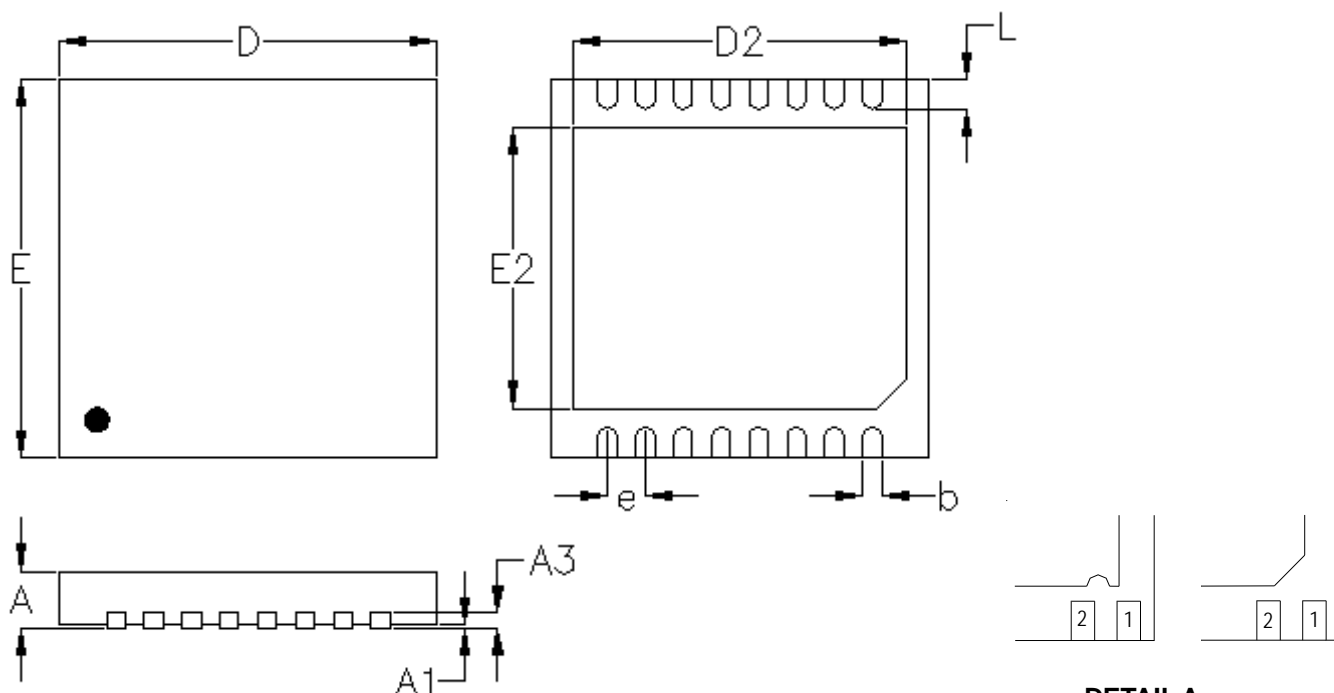

Figure 5. PCB Layout Guide

Outline Dimension



DETAIL A

Pin #1 ID and Tie Bar Mark Options

Note : The configuration of the Pin #1 identifier is optional, but must be located within the zone indicated.

Symbol	Dimensions In Millimeters		Dimensions In Inches	
	Min.	Max.	Min.	Max.
A	0.700	0.800	0.028	0.031
A1	0.000	0.050	0.000	0.002
A3	0.175	0.250	0.007	0.010
b	0.200	0.300	0.008	0.012
D	4.900	5.100	0.193	0.201
D2	4.350	4.450	0.171	0.175
E	4.900	5.100	0.193	0.201
E2	3.650	3.750	0.144	0.148
e	0.500		0.020	
L	0.350	0.450	0.014	0.018

W-Type 16L DFN 5x5 Package

Footprint Information

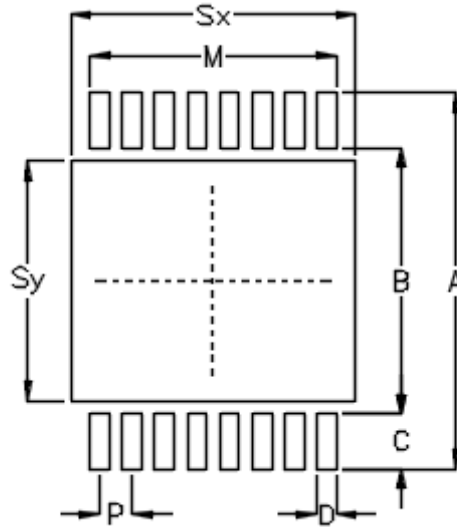

Package	Number of Pin	Footprint Dimension (mm)								Tolerance
		P	A	B	C	D	Sx	Sy	M	
V/W/U/XDFN5x5-16	16	0.50	5.80	4.10	0.85	0.30	4.40	3.70	3.80	±0.05

Richtek Technology Corporation

14F, No. 8, Tai Yuen 1st Street, Chupei City
 Hsinchu, Taiwan, R.O.C.
 Tel: (8863)5526789

Richtek products are sold by description only. Richtek reserves the right to change the circuitry and/or specifications without notice at any time. Customers should obtain the latest relevant information and data sheets before placing orders and should verify that such information is current and complete. Richtek cannot assume responsibility for use of any circuitry other than circuitry entirely embodied in a Richtek product. Information furnished by Richtek is believed to be accurate and reliable. However, no responsibility is assumed by Richtek or its subsidiaries for its use; nor for any infringements of patents or other rights of third parties which may result from its use. No license is granted by implication or otherwise under any patent or patent rights of Richtek or its subsidiaries.

Looking for pricing, stock, or lifecycle information?

Click below to explore more details on WIN SOURCE:

-  [View RT8549LGQW on WIN SOURCE](#)
-  [Richtek USA Inc. Information](#)

Optimize Your Supply Chain with WIN SOURCE Solutions

-  Global Sourcing Solution
-  Obsolete Management
-  Cost Control Management
-  Shortage Management
-  Alternative Solution
-  Excess Inventory Management