



**THE DATASHEET OF
MC100EP445FAR2**



MC10EP445, MC100EP445

3.3V/5V ECL 8-Bit Serial/Parallel Converter

Description

The MC10/100EP445 is an integrated 8-bit differential serial to parallel data converter with asynchronous data synchronization. The device has two modes of operation. CKSEL HIGH mode is designed to operate NRZ data rates of up to 3.3 Gb/s, while CKSEL LOW mode is designed to operate at twice the internal clock data rate of up to 5.0 Gb/s. The conversion sequence was chosen to convert the first serial bit to Q0, the second bit to Q1, etc. Two selectable differential serial inputs, which are selected by SINSEL, provide this device with loop-back testing capability. The MC10/100EP445 has a SYNC pin which, when held high for at least two consecutive clock cycles, will swallow one bit of data shifting the start of the conversion data from D_n to D_{n+1} . Each additional shift requires an additional pulse to be applied to the SYNC pin.

Control pins are provided to reset and disable internal clock circuitry. Additionally, V_{BB} pin is provided for single-ended input condition.

The 100 Series contains temperature compensation.

Features

- 1530 ps Propagation Delay
- 5.0 Gb/s Typical Data Rate for CLKSEL LOW Mode
- Differential Clock and Serial Inputs
- V_{BB} Output for Single-Ended Input Applications
- Asynchronous Data Synchronization (SYNC)
- Asynchronous Master Reset (RESET)
- PECL Mode Operating Range: $V_{CC} = 3.0\text{ V}$ to 5.5 V with $V_{EE} = 0\text{ V}$
- NECL Mode Operating Range: $V_{CC} = 0\text{ V}$ with $V_{EE} = -3.0\text{ V}$ to -5.5 V
- Open Input Default State
- CLK ENABLE Immune to Runt Pulse Generation
- These Devices are Pb-Free and are RoHS Compliant



ON Semiconductor®

<http://onsemi.com>

MARKING DIAGRAM*



LQFP-32
FA SUFFIX
CASE 873A

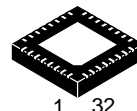
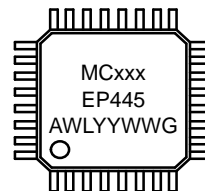

QFN32
MN SUFFIX
CASE 488AM

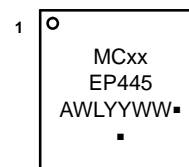

xxx = 10 or 100
A = Assembly Location
WL = Wafer Lot
YY = Year
WW = Work Week
G or ■ = Pb-Free Package

(Note: Microdot may be in either location)

*For additional marking information, refer to Application Note AND8002/D.

ORDERING INFORMATION

See detailed ordering and shipping information in the package dimensions section on page 17 of this data sheet.

MC10EP445, MC100EP445

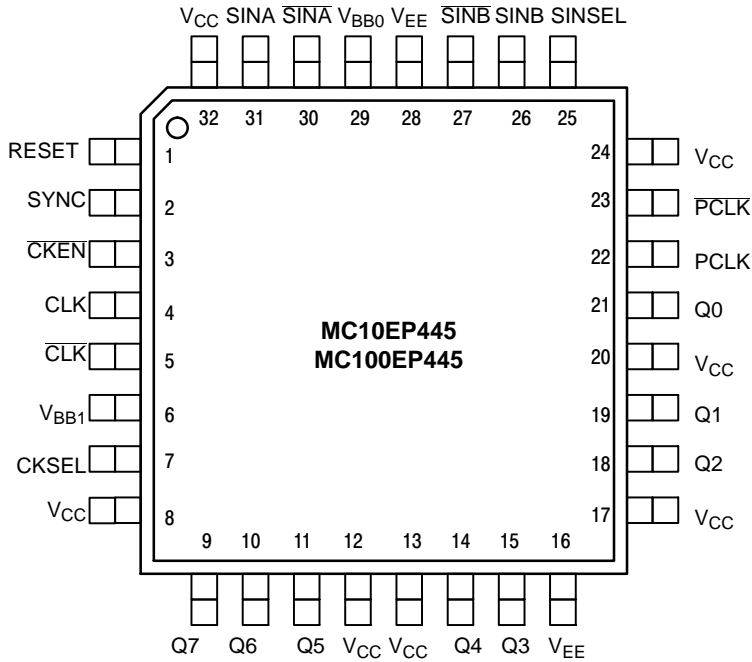

Warning: All V_{CC} and V_{EE} pins must be externally connected to Power Supply to guarantee proper operation.

Figure 1. 32-Lead LQFP Pinout (Top View)

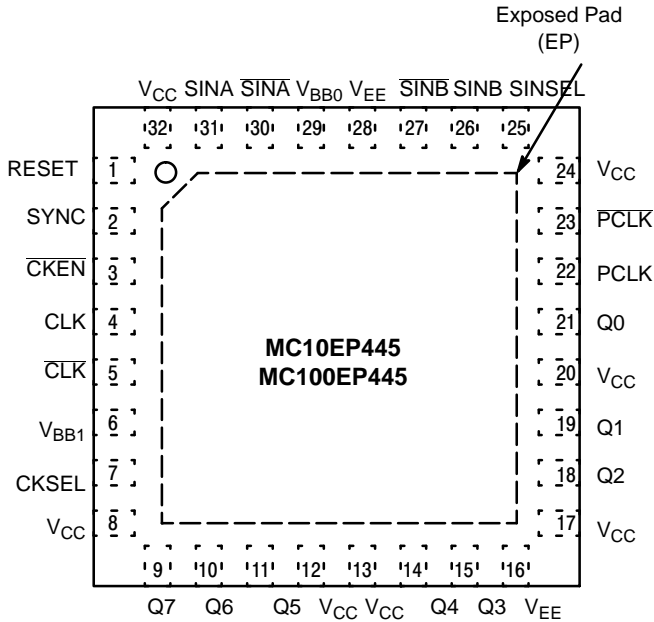

Figure 2. 32-Lead QFN Pinout (Top View)



Table 1. PIN DESCRIPTION

Pin	Function
SINA*, $\overline{\text{SINA}}^*$	ECL Differential Serial Data Input A
SINB*, $\overline{\text{SINB}}^*$	ECL Differential Serial Data Input B
SINESEL*	ECL Serial Input Selector Pin
Q0–Q7	ECL Parallel Data Outputs
CLK*, $\overline{\text{CLK}}^*$	ECL Differential Clock Inputs
PCLK, $\overline{\text{PCLK}}$	ECL Differential Parallel Clock Output
SYNC*	ECL Conversion Synchronizing Input
CKSEL*	ECL Clock Input Selector Pin
$\overline{\text{CKEN}}^*$	ECL Clock Enable Pin
RESET*	ECL Reset Pin
V_{BB0} , V_{BB1}	Output Reference Voltage
V_{CC}	Positive Supply
V_{EE}	Negative Supply
EP	The exposed pad (EP) on the QFN–32 package bottom is thermally connected to the die for improved heat transfer out of the package. The exposed pad must be attached to a heat-sinking conduit. The pad is electrically connected to V_{EE} .

* Pins will default logic LOW or differential logic LOW when left open.

MC10EP445, MC100EP445

Table 2. TRUTH TABLE

PIN	FUNCTION	
	High	Low
SINSEL	Select SINB Input	Select SINA Input
CKSEL	Q: PCLK = 8:1 CLK: Q = 1:1 	Q: PCLK = 8:1 CLK: Q = 1:2 
CKEN	Synchronously Disable Internal Clock Circuitry	Synchronously Enable Internal Clock Circuitry
RESET	Asynchronous Master Reset	Synchronous Enable
SYNC	Asynchronously Applied to Swallow a Data Bit	Normal Conversion Process

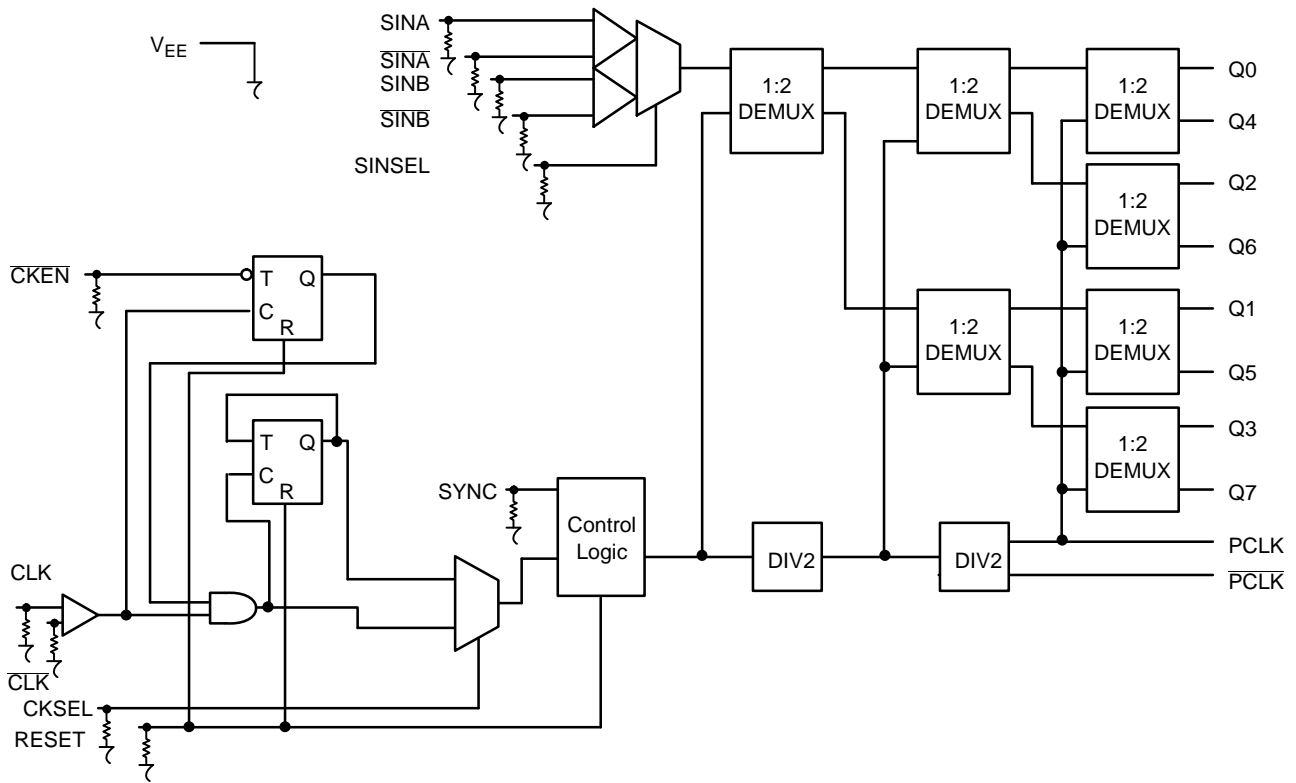

Figure 3. Logic Diagram

MC10EP445, MC100EP445

Table 3. ATTRIBUTES

Characteristics		Value	
Internal Input Pulldown Resistor		75 kΩ	
Internal Input Pull-up Resistor		N/A	
ESD Protection	Human Body Model Machine Model Charged Device Model	> 2 kV > 200 V > 2 kV	
Moisture Sensitivity, Indefinite Time Out of Drypack (Note 1)		Pb Pkg	Pb-Free Pkg
	LQFP-32 QFN-32	Level 2 N/A	Level 2 Level 1
Flammability Rating	Oxygen Index: 28 to 34	UL 94 V-0 @ 0.125 in	
Transistor Count		993 Devices	
Meets or exceeds JEDEC Spec EIA/JESD78 IC Latchup Test			

1. For additional information, see Application Note AND8003/D.

Table 4. MAXIMUM RATINGS

Symbol	Parameter	Condition 1	Condition 2	Rating	Unit
V _{CC}	PECL Mode Power Supply	V _{EE} = 0 V		6	V
V _{EE}	NECL Mode Power Supply	V _{CC} = 0 V		-6	V
V _I	PECL Mode Input Voltage NECL Mode Input Voltage	V _{EE} = 0 V V _{CC} = 0 V	V _I ≤ V _{CC} V _I ≥ V _{EE}	6 -6	V V
I _{out}	Output Current	Continuous Surge		50 100	mA mA
I _{BB}	V _{BB} Sink/Source			± 0.5	mA
T _A	Operating Temperature Range			-40 to +85	°C
T _{stg}	Storage Temperature Range			-65 to +150	°C
θ _{JA}	Thermal Resistance (Junction-to-Ambient)	0 lfpm 500 lfpm	32 LQFP 32 LQFP	80 55	°C/W °C/W
θ _{JC}	Thermal Resistance (Junction-to-Case)	Standard Board	32 LQFP	12 to 17	°C/W
θ _{JA}	Thermal Resistance (Junction-to-Ambient)	0 lfpm 500 lfpm	QFN-32 QFN-32	31 27	°C/W °C/W
θ _{JC}	Thermal Resistance (Junction-to-Case)	2S2P	QFN-32	12	°C/W
T _{sol}	Wave Solder Pb-Free	<2 to 3 sec @ 260°C		265	°C

Stresses exceeding those listed in the Maximum Ratings table may damage the device. If any of these limits are exceeded, device functionality should not be assumed, damage may occur and reliability may be affected.

MC10EP445, MC100EP445

Table 5. 10EP DC CHARACTERISTICS, PECL $V_{CC} = 3.3\text{ V}$, $V_{EE} = 0\text{ V}$ (Note 2)

Symbol	Characteristic	-40°C			25°C			85°C			Unit
		Min	Typ	Max	Min	Typ	Max	Min	Typ	Max	
I_{EE}	Power Supply Current	95	119	143	98	122	146	100	125	150	mA
V_{OH}	Output HIGH Voltage (Note 3)	2165	2290	2415	2230	2355	2480	2290	2415	2540	mV
V_{OL}	Output LOW Voltage (Note 3)	1365	1490	1615	1430	1555	1680	1490	1615	1740	mV
V_{IH}	Input HIGH Voltage (Single-Ended)	2090		2415	2155		2480	2215		2540	mV
V_{IL}	Input LOW Voltage (Single-Ended)	1365		1690	1460		1755	1490		1815	mV
V_{BB}	Output Voltage Reference	1790	1890	1990	1855	1955	2055	1915	2015	2115	mV
V_{IHCMR}	Input HIGH Voltage Common Mode Range (Differential Configuration) (Note 4)	2.0		3.3	2.0		3.3	2.0		3.3	V
I_{IH}	Input HIGH Current			150			150			150	μA
I_{IL}	Input LOW Current	0.5			0.5			0.5			μA

NOTE: Device will meet the specifications after thermal equilibrium has been established when mounted in a test socket or printed circuit board with maintained transverse airflow greater than 500 lfm. Electrical parameters are guaranteed only over the declared operating temperature range. Functional operation of the device exceeding these conditions is not implied. Device specification limit values are applied individually under normal operating conditions and not valid simultaneously.

- Input and output parameters vary 1:1 with V_{CC} . V_{EE} can vary +0.3 V to -2.2 V.
- All loading with 50 Ω to $V_{CC} - 2.0\text{ V}$.
- V_{IHCMR} min varies 1:1 with V_{EE} . V_{IHCMR} max varies 1:1 with V_{CC} . The V_{IHCMR} range is referenced to the most positive side of the differential input signal.

Table 6. 10EP DC CHARACTERISTICS, PECL $V_{CC} = 5.0\text{ V}$, $V_{EE} = 0\text{ V}$ (Note 5)

Symbol	Characteristic	-40°C			25°C			85°C			Unit
		Min	Typ	Max	Min	Typ	Max	Min	Typ	Max	
I_{EE}	Power Supply Current (Note 6)	95	119	143	98	122	146	100	125	150	mA
V_{OH}	Output HIGH Voltage (Note 7)	3865	3990	4115	3930	4055	4180	3990	4115	4240	mV
V_{OL}	Output LOW Voltage (Note 7)	3065	3190	3315	3130	3255	3380	3190	3315	3440	mV
V_{IH}	Input HIGH Voltage (Single-Ended)	3790		4115	3855		4180	3915		4240	mV
V_{IL}	Input LOW Voltage (Single-Ended)	3065		3390	3130		3455	3190		3515	mV
V_{BB}	Output Voltage Reference	3490	3590	3690	3555	3655	3755	3615	3715	3815	mV
V_{IHCMR}	Input HIGH Voltage Common Mode Range (Differential Configuration) (Note 8)	2.0		5.0	2.0		5.0	2.0		5.0	V
I_{IH}	Input HIGH Current			150			150			150	μA
I_{IL}	Input LOW Current	0.5			0.5			0.5			μA

NOTE: Device will meet the specifications after thermal equilibrium has been established when mounted in a test socket or printed circuit board with maintained transverse airflow greater than 500 lfm. Electrical parameters are guaranteed only over the declared operating temperature range. Functional operation of the device exceeding these conditions is not implied. Device specification limit values are applied individually under normal operating conditions and not valid simultaneously.

- Input and output parameters vary 1:1 with V_{CC} . V_{EE} can vary +2.0 V to -0.5 V.
- Required 500 lfm air flow when using +5 V power supply. For $(V_{CC} - V_{EE}) > 3.3\text{ V}$, 5 Ω to 10 Ω in line with V_{EE} required for maximum thermal protection at elevated temperatures. Recommend $V_{CC} - V_{EE}$ operation at $\leq 3.3\text{ V}$.
- All loading with 50 Ω to $V_{CC} - 2.0\text{ V}$.
- V_{IHCMR} min varies 1:1 with V_{EE} . V_{IHCMR} max varies 1:1 with V_{CC} . The V_{IHCMR} range is referenced to the most positive side of the differential input signal.

MC10EP445, MC100EP445

Table 7. 10EP DC CHARACTERISTICS, NECL $V_{CC} = 0\text{ V}$, $V_{EE} = -5.5\text{ V to }-3.0\text{ V}$ (Note 9)

Symbol	Characteristic	-40°C			25°C			85°C			Unit
		Min	Typ	Max	Min	Typ	Max	Min	Typ	Max	
I_{EE}	Power Supply Current (Note 10)	95	119	143	98	122	146	100	125	150	mA
V_{OH}	Output HIGH Voltage (Note 11)	-1135	-1010	-885	-1070	-945	-820	-1010	-885	-760	mV
V_{OL}	Output LOW Voltage (Note 11)	-1935	-1810	-1685	-1870	-1745	-1620	-1810	-1685	-1560	mV
V_{IH}	Input HIGH Voltage (Single-Ended)	-1210		-885	-1145		-820	-1085		-760	mV
V_{IL}	Input LOW Voltage (Single-Ended)	-1935		-1610	-1870		-1545	-1810		-1485	mV
V_{BB}	Output Voltage Reference	-1510	-1410	-1310	-1445	-1345	-1245	-1385	-1285	-1185	mV
V_{IHCMR}	Input HIGH Voltage Common Mode Range (Differential Configuration) (Note 12)	$V_{EE}+2.0$		0.0	$V_{EE}+2.0$		0.0	$V_{EE}+2.0$		0.0	V
I_{IH}	Input HIGH Current			150			150			150	μA
I_{IL}	Input LOW Current	0.5			0.5			0.5			μA

NOTE: Device will meet the specifications after thermal equilibrium has been established when mounted in a test socket or printed circuit board with maintained transverse airflow greater than 500 lfm. Electrical parameters are guaranteed only over the declared operating temperature range. Functional operation of the device exceeding these conditions is not implied. Device specification limit values are applied individually under normal operating conditions and not valid simultaneously.

9. Input and output parameters vary 1:1 with V_{CC} .

10. Required 500 lfm air flow when using -5 V power supply. For $(V_{CC} - V_{EE}) > 3.3\text{ V}$, 5 Ω to 10 Ω in line with V_{EE} required for maximum thermal protection at elevated temperatures. Recommend $V_{CC}-V_{EE}$ operation at $\leq 3.3\text{ V}$.

11. All loading with 50 Ω to $V_{CC} - 2.0\text{ V}$.

12. V_{IHCMR} min varies 1:1 with V_{EE} , V_{IHCMR} max varies 1:1 with V_{CC} . The V_{IHCMR} range is referenced to the most positive side of the differential input signal.

Table 8. 100EP DC CHARACTERISTICS, PECL $V_{CC} = 3.3\text{ V}$, $V_{EE} = 0\text{ V}$ (Note 13)

Symbol	Characteristic	-40°C			25°C			85°C			Unit
		Min	Typ	Max	Min	Typ	Max	Min	Typ	Max	
I_{EE}	Power Supply Current	95	119	143	98	122	146	100	125	150	mA
V_{OH}	Output HIGH Voltage (Note 14)	2155	2280	2405	2155	2280	2405	2155	2280	2405	mV
V_{OL}	Output LOW Voltage (Note 14)	1305	1480	1605	1305	1480	1605	1305	1480	1605	mV
V_{IH}	Input HIGH Voltage (Single-Ended)	2075		2420	2075		2420	2075		2420	mV
V_{IL}	Input LOW Voltage (Single-Ended)	1305		1675	1305		1675	1305		1675	mV
V_{BB}	Output Voltage Reference	1775	1875	1975	1775	1875	1975	1775	1875	1975	mV
V_{IHCMR}	Input HIGH Voltage Common Mode Range (Differential Configuration) (Note 15)	2.0		3.3	2.0		3.3	2.0		3.3	V
I_{IH}	Input HIGH Current			150			150			150	μA
I_{IL}	Input LOW Current	0.5			0.5			0.5			μA

NOTE: Device will meet the specifications after thermal equilibrium has been established when mounted in a test socket or printed circuit board with maintained transverse airflow greater than 500 lfm. Electrical parameters are guaranteed only over the declared operating temperature range. Functional operation of the device exceeding these conditions is not implied. Device specification limit values are applied individually under normal operating conditions and not valid simultaneously.

13. Input and output parameters vary 1:1 with V_{CC} . V_{EE} can vary +0.3 V to -2.2 V.

14. All loading with 50 Ω to $V_{CC} - 2.0\text{ V}$.

15. V_{IHCMR} min varies 1:1 with V_{EE} , V_{IHCMR} max varies 1:1 with V_{CC} . The V_{IHCMR} range is referenced to the most positive side of the differential input signal.

MC10EP445, MC100EP445

Table 9. 100EP DC CHARACTERISTICS, PECL $V_{CC} = 5.0\text{ V}$, $V_{EE} = 0\text{ V}$ (Note 16)

Symbol	Characteristic	-40°C			25°C			85°C			Unit
		Min	Typ	Max	Min	Typ	Max	Min	Typ	Max	
I_{EE}	Power Supply Current (Note 17)	95	119	143	98	122	146	100	125	150	mA
V_{OH}	Output HIGH Voltage (Note 18)	3855	3980	4105	3855	3980	4105	3855	3980	4105	mV
V_{OL}	Output LOW Voltage (Note 18)	3005	3180	3305	3005	3180	3305	3005	3180	3305	mV
V_{IH}	Input HIGH Voltage (Single-Ended)	3775		4120	3775		4120	3775		4120	mV
V_{IL}	Input LOW Voltage (Single-Ended)	3005		3375	3005		3375	3005		3375	mV
V_{BB}	Output Voltage Reference	3475	3575	3675	3475	3575	3675	3475	3575	3675	mV
V_{IHCMR}	Input HIGH Voltage Common Mode Range (Differential Configuration) (Note 19)	2.0		5.0	2.0		5.0	2.0		5.0	V
I_{IH}	Input HIGH Current			150			150			150	μA
I_{IL}	Input LOW Current	0.5			0.5			0.5			μA

NOTE: Device will meet the specifications after thermal equilibrium has been established when mounted in a test socket or printed circuit board with maintained transverse airflow greater than 500 lfm. Electrical parameters are guaranteed only over the declared operating temperature range. Functional operation of the device exceeding these conditions is not implied. Device specification limit values are applied individually under normal operating conditions and not valid simultaneously.

16. Input and output parameters vary 1:1 with V_{CC} . V_{EE} can vary +2.0 V to -0.5 V.

17. Required 500 lfm air flow when using +5 V power supply. For $(V_{CC} - V_{EE}) > 3.3\text{ V}$, 5 Ω to 10 Ω in line with V_{EE} required for maximum thermal protection at elevated temperatures. Recommend $V_{CC} - V_{EE}$ operation at $\leq 3.3\text{ V}$.

18. All loading with 50 Ω to $V_{CC} - 2.0\text{ V}$.

19. V_{IHCMR} min varies 1:1 with V_{EE} . V_{IHCMR} max varies 1:1 with V_{CC} . The V_{IHCMR} range is referenced to the most positive side of the differential input signal.

Table 10. 100EP DC CHARACTERISTICS, NECL $V_{CC} = 0\text{ V}$, $V_{EE} = -5.5\text{ V}$ to -3.0 V (Note 20)

Symbol	Characteristic	-40°C			25°C			85°C			Unit
		Min	Typ	Max	Min	Typ	Max	Min	Typ	Max	
I_{EE}	Power Supply Current (Note 21)	95	119	143	98	122	146	100	125	150	mA
V_{OH}	Output HIGH Voltage (Note 22)	-1145	-1020	-895	-1145	-1020	-895	-1145	-1020	-895	mV
V_{OL}	Output LOW Voltage (Note 22)	-1995	-1820	-1695	-1995	-1820	-1695	-1995	-1820	-1695	mV
V_{IH}	Input HIGH Voltage (Single-Ended)	-1225		-880	-1225		-880	-1225		-880	mV
V_{IL}	Input LOW Voltage (Single-Ended)	-1995		-1625	-1995		-1625	-1995		-1625	mV
V_{BB}	Output Voltage Reference	-1525	-1425	-1325	-1525	-1425	-1325	-1525	-1425	-1325	mV
V_{IHCMR}	Input HIGH Voltage Common Mode Range (Differential Configuration) (Note 23)	$V_{EE} + 2.0$		0.0	$V_{EE} + 2.0$		0.0	$V_{EE} + 2.0$		0.0	V
I_{IH}	Input HIGH Current			150			150			150	μA
I_{IL}	Input LOW Current	0.5			0.5			0.5			μA

NOTE: Device will meet the specifications after thermal equilibrium has been established when mounted in a test socket or printed circuit board with maintained transverse airflow greater than 500 lfm. Electrical parameters are guaranteed only over the declared operating temperature range. Functional operation of the device exceeding these conditions is not implied. Device specification limit values are applied individually under normal operating conditions and not valid simultaneously.

20. Input and output parameters vary 1:1 with V_{CC} .

21. Required 500 lfm air flow when using -5.0 V power supply. For $(V_{CC} - V_{EE}) > 3.3\text{ V}$, 5 Ω to 10 Ω in line with V_{EE} required for maximum thermal protection at elevated temperatures. Recommend $V_{CC} - V_{EE}$ operation at $\leq 3.3\text{ V}$.

22. All loading with 50 Ω to $V_{CC} - 2.0\text{ V}$.

23. V_{IHCMR} min varies 1:1 with V_{EE} . V_{IHCMR} max varies 1:1 with V_{CC} . The V_{IHCMR} range is referenced to the most positive side of the differential input signal.

MC10EP445, MC100EP445

Table 11. AC CHARACTERISTICS $V_{CC} = 0\text{ V}$; $V_{EE} = -3.0\text{ V}$ to -5.5 V or $V_{CC} = 3.0\text{ V}$ to 5.5 V ; $V_{EE} = 0\text{ V}$ (Note 24)

Symbol	Characteristic	-40°C			25°C			85°C			Unit
		Min	Typ	Max	Min	Typ	Max	Min	Typ	Max	
f_{\max}	Maximum Input CLK Frequency (See Figure 13. F_{\max}/JITTER) CKSEL = LOW CKSEL = HIGH	2.0 2.8	2.5 3.3		2.0 2.8	2.5 3.3		1.7 2.8	2.2 3.3		GHz
t_{PLH} , t_{PHL}	Propagation Delay to Output Differential CLK to Q CLK TO PCLK	1280 1000	1475 1240	1710 1490	1335 1050	1557 1310	1795 1580	1450 1140	1663 1420	1950 1710	ps
t_s	Setup Time SINA, B+ TO CLK+ (Figure 5) $\overline{\text{CKEN}}$ TO CLK- (Figure 6)	-400 100	-459 50		-420 100	-479 50		-440 100	-492 50		ps
t_h	Hold Time CLK+ TO SINA, B- (Figure 5) CLK- TO $\overline{\text{CKEN}}$ (Figure 6)	533 45	474 -35		550 45	490 -35		560 45	508 -35		ps
$t_{\text{RR}}/\overline{t_{\text{RR}2}}$	Reset Recovery (Figure 4)	350	180		350	180		350	180		ps
t_{PW}	Minimum Pulse Width RESET	400			400			400			ps
t_{JITTER}	RMS Random Clock Jitter @ 2.0 GHz CLK_SEL LOW @ 2.5 GHz CLK_SELF HIGH @ 3.0 GHz CLK_SEL HIGH			1.5 1.0 1.5			1.5 1.0 2.0			1.5 1.5 2.5	ps
V_{PP}	Input Voltage Swing (Differential Configuration) (Note 25)	150	800	1200	150	800	1200	150	800	1200	mV
t_r , t_f	Output Rise/Fall Times (20% – 80%) Q/ $\overline{\text{Q}}$ PCLK/ $\overline{\text{PCLK}}$	100 100	180 180	400 250	100 100	200 200	400 300	125 125	230 230	425 325	ps

NOTE: Device will meet the specifications after thermal equilibrium has been established when mounted in a test socket or printed circuit board with maintained transverse airflow greater than 500 lfm. Electrical parameters are guaranteed only over the declared operating temperature range. Functional operation of the device exceeding these conditions is not implied. Device specification limit values are applied individually under normal operating conditions and not valid simultaneously.

24. Measured using a 750 mV source, 50% duty cycle clock source. All loading with $50\ \Omega$ to $V_{CC} - 2.0\text{ V}$.

25. $V_{\text{PP}}(\text{min})$ is the minimum input swing for which AC parameters are guaranteed.

MC10EP445, MC100EP445

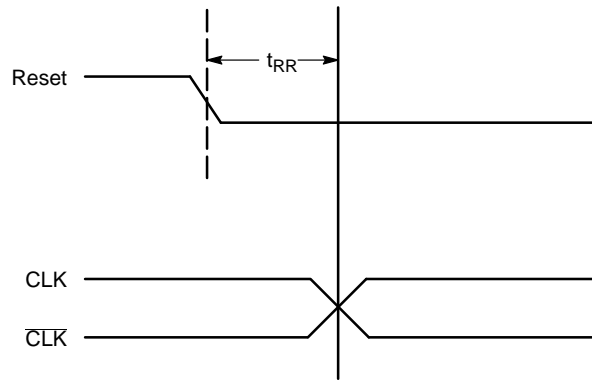

Figure 4. Reset Recovery

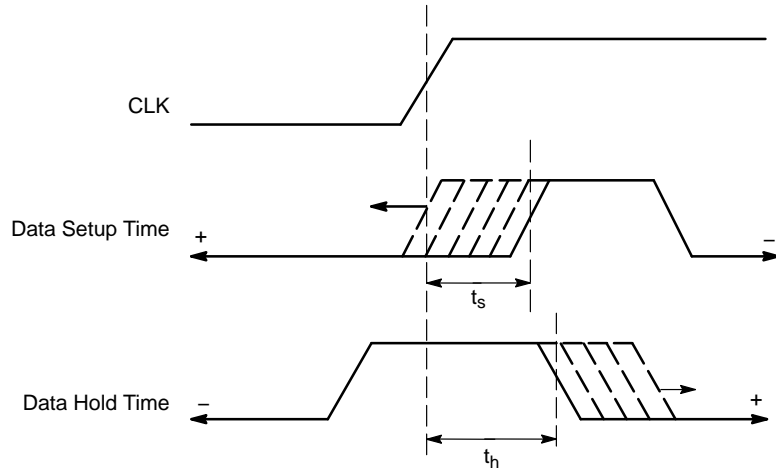

Figure 5. Data Setup and Hold Time

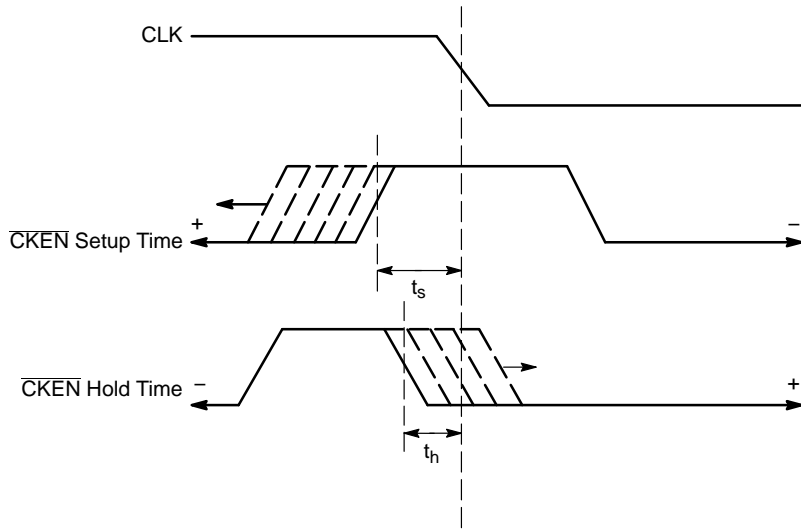

Figure 6. \overline{CKEN} Setup and Hold Time

MC10EP445, MC100EP445

APPLICATION INFORMATION

The MC10/100EP445 is an integrated 1:8 serial to parallel converter with two modes of operation selected by CKSEL (Pin 7). CKSEL HIGH mode only latches data on the rising edge of the input CLK and CKSEL LOW mode latches data on both the rising and falling edge of the input CLK. CKSEL LOW is the open default state. Either of the two differential input serial data path provided for this device, SINA and SINB, can be chosen with the SINSEL pin (pin 25). SINA is the default input path when SINSEL pin is left floating. Because of internal pull-downs on the input pins, all input pins will default to logic low when left open.

The two selectable serial data paths can be used for loop-back testing as well as the bit error testing.

Upon power-up, the internal flip-flops will attain a random state. To synchronize multiple flip-flops in the device, the Reset (pin 1) must be asserted. The reset pin will disable the internal clock signal irrespective of the CKEN state (CKEN disables the internal clock circuitry). The device will grab the first stream of data after the falling edge of RESET^①, followed by the falling edge of CLK^②, on second rising edge of CLK^③ in either CKSEL modes. (See Figure 6)

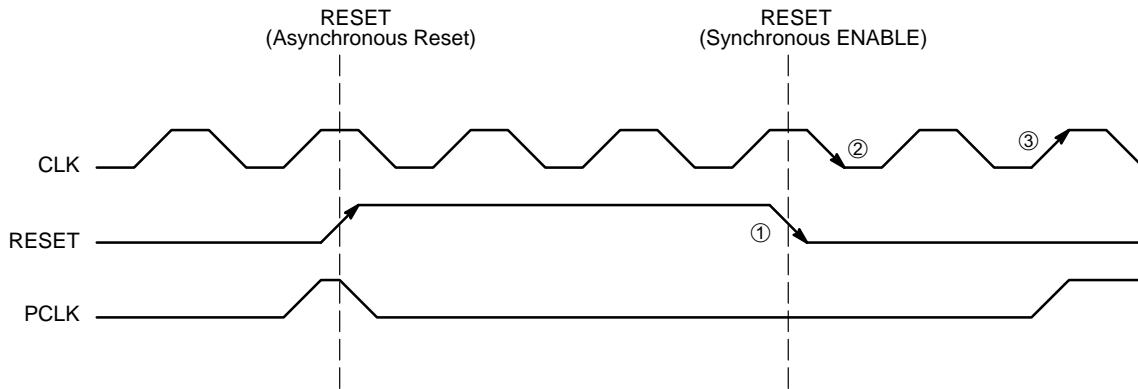

Figure 7. Reset Timing Diagram

MC10EP445, MC100EP445

For CKSEL LOW operation, the data is latched on both the rising edge and the falling edge of the clock and the time from when the serial data is latched^① to when the data is seen on the parallel output^② is 6 clock cycles (see Figure 8).

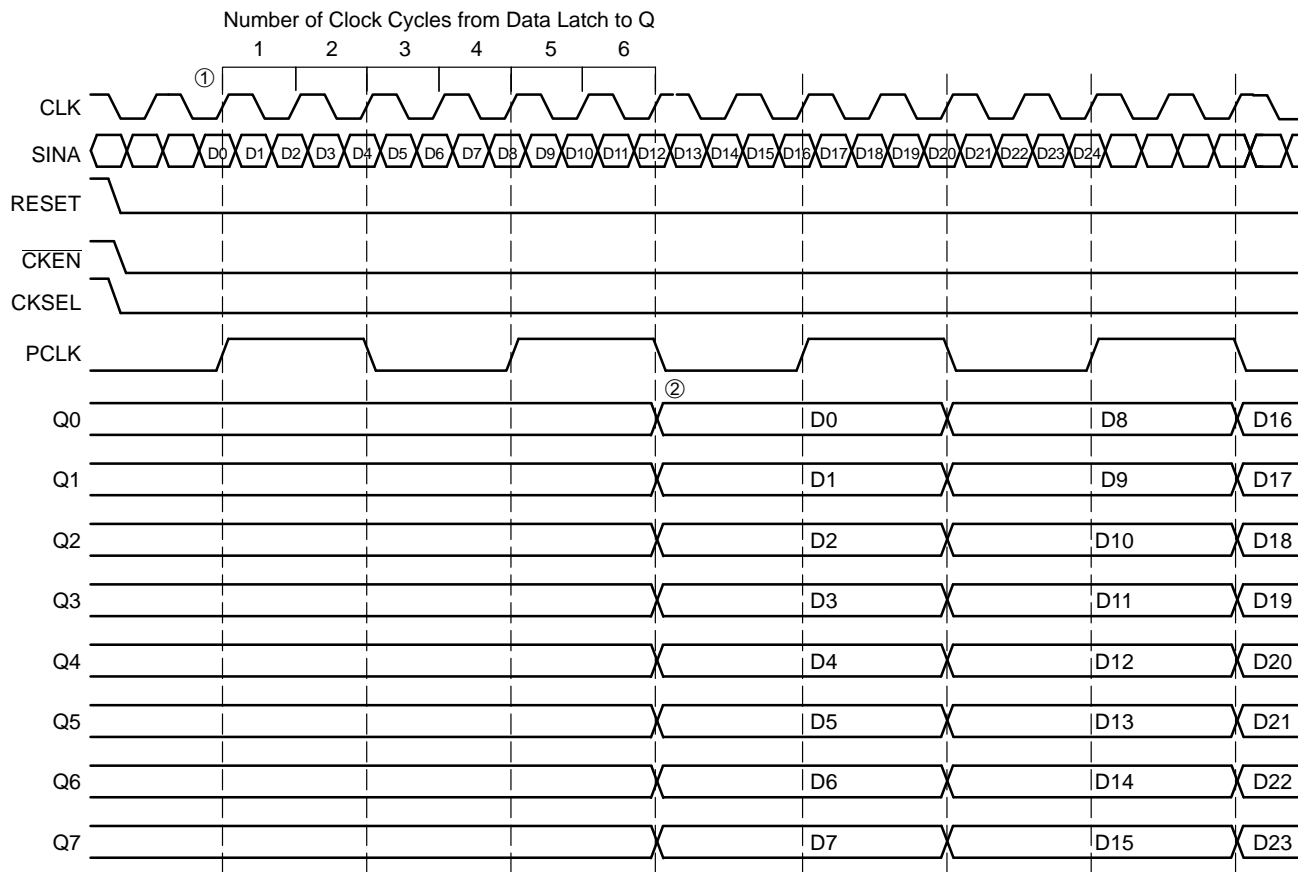

Figure 8. Timing Diagram A. 1:8 Serial to Parallel Conversion with CKSEL LOW

MC10EP445, MC100EP445

Similarly, for CKSEL HIGH operation, the data is latched only on the rising edge of the clock and the time from when the serial data is latched^① to when the data is seen on the parallel output^② is 12 clock cycles (see Figure 9).

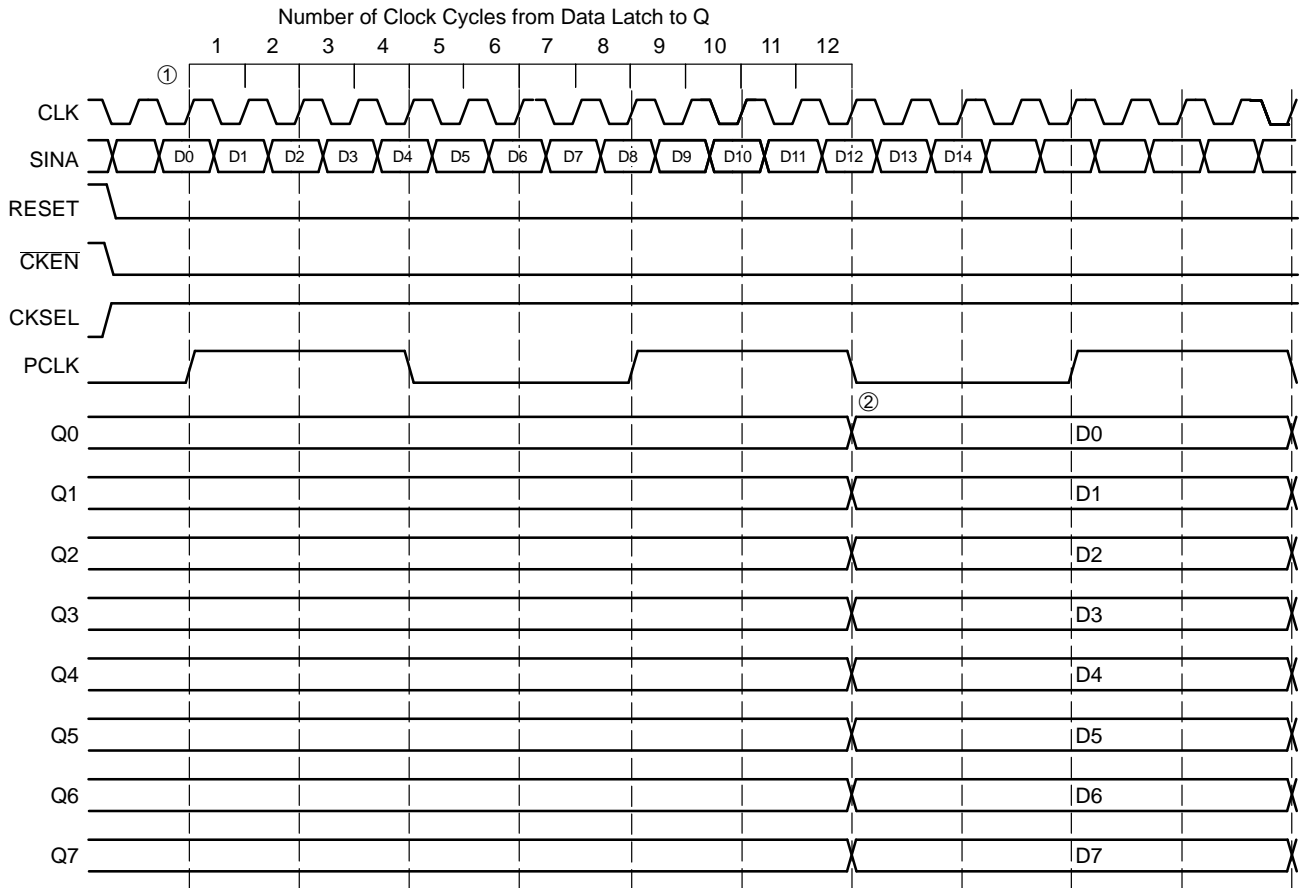

Figure 9. Timing Diagram A. 1:8 Serial to Parallel Conversion with CKSEL HIGH

MC10EP445, MC100EP445

To allow the user to synchronize the output byte data correctly, the start bit for conversion can be moved using the SYNC input pin (pin 2). Asynchronously asserting the SYNC pin will force the internal clock to swallow a clock pulse, effectively shifting a bit from the Q_n to the Q_{n-1} output as shown in Figure 10 and Figure 11. For CKSEL LOW, a single pulse asynchronously for two consecutive

clock cycles shifts the start bit for conversion from Q_n to Q_{n-1} . The bit is swallowed following the two clock cycle pulse width of SYNC^① on the next triggering edge of clock^② (either on the rising or the falling edge of the clock). Each additional shift requires an additional pulse to be applied to the SYNC pin. (See Figure 10)

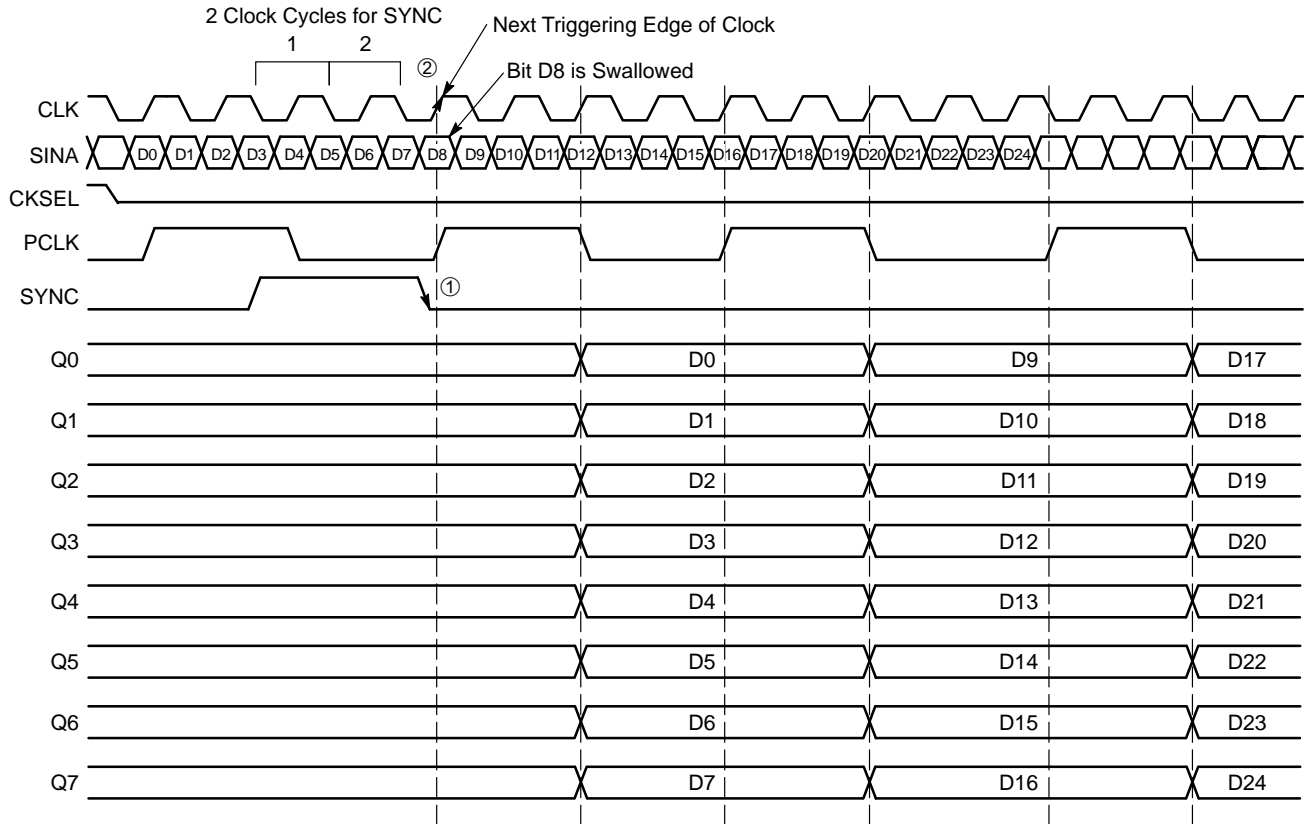

Figure 10. Timing Diagram A. 1:8 Serial to Parallel Conversion with SYNC Pulse at CKSEL LOW

MC10EP445, MC100EP445

For CKSEL HIGH, a single pulse applied asynchronously for three consecutive clock cycles shifts the start bit for conversion from Q_n to Q_{n-1} . The bit is swallowed following the three clock cycle pulse width of SYNC on the next

triggering edge of clock^② (on the rising edge of the clock only). Each additional shift requires an additional pulse to be applied to the SYNC pin. (See Figure 11)

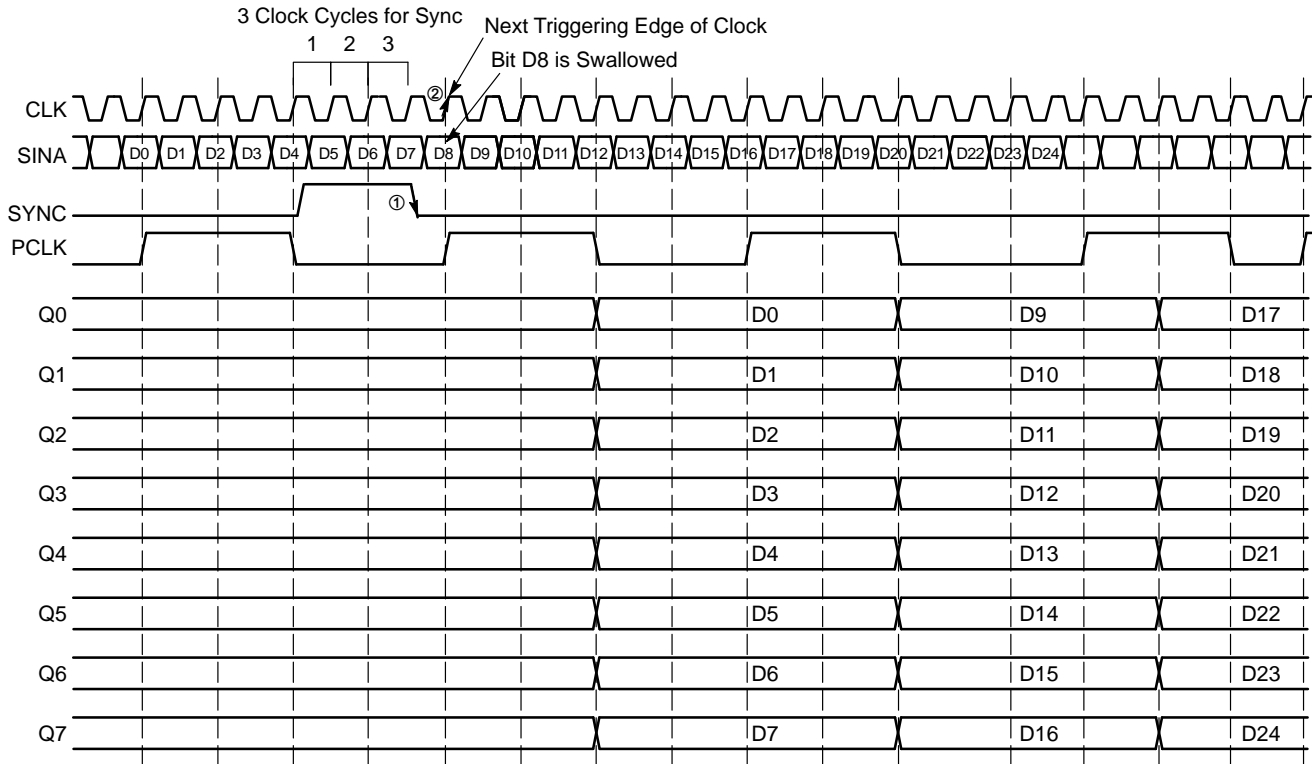

Figure 11. Timing Diagram A. 1:8 Serial to Parallel Conversion with SYNC Pulse at CKSEL HIGH

MC10EP445, MC100EP445

The synchronous $\overline{\text{CKEN}}$ (pin 3) applied with at least one clock cycle pulse length will disable the internal clock signal. The synchronous $\overline{\text{CKEN}}$ will suspend all of the device activities and prevent runt pulses from being generated. The rising edge of $\overline{\text{CKEN}}$ followed by the falling

edge of CLK will suspend all activities. The first data bit will clock on the rising edge, since the falling edge of $\overline{\text{CKEN}}$ followed by the falling edge of the incoming clock triggers the enabling of the internal process. (See Figure 12)

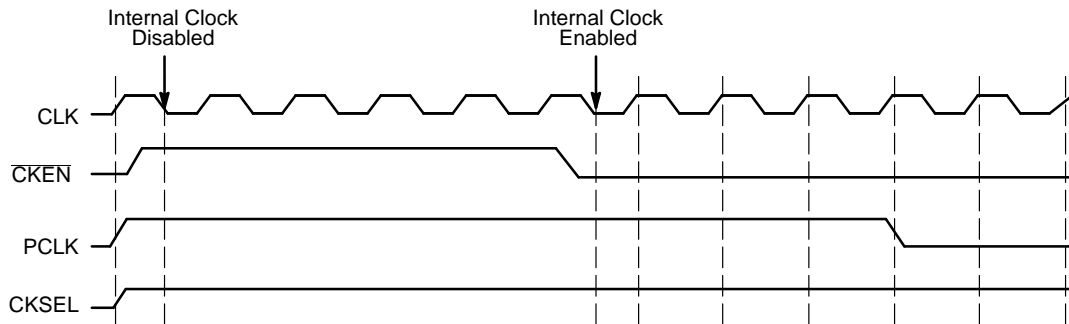

Figure 12. Timing Diagram with CKEN with CKSEL HIGH

The differential PCLK output (pins 22 and 23) is a word framer and can help the user to synchronize the parallel data outputs. During CKSEL LOW operation, the PCLK will provide a divide by 4-clock frequency, which frames the serial data in period of PCLK output. Likewise during CKSEL HIGH operation, the PCLK will provide a divide by 8-clock frequency.

The V_{BB} pin, an internally generated voltage supply, is available to this device only. For single-ended input

conditions, the unused differential input is connected to V_{BB} as a switching reference voltage. V_{BB} may also rebias AC coupled inputs. When used, decouple V_{BB} and V_{CC} via a $0.01 \mu\text{F}$ capacitor, which will limit the current sourcing or sinking to 0.5mA . When not used, V_{BB} should be left open. Also, both outputs of the differential pair must be terminated (50Ω to $V_{\text{TT}} = V_{\text{CC}} - 2 \text{V}$) even if only one output is used.

MC10EP445, MC100EP445

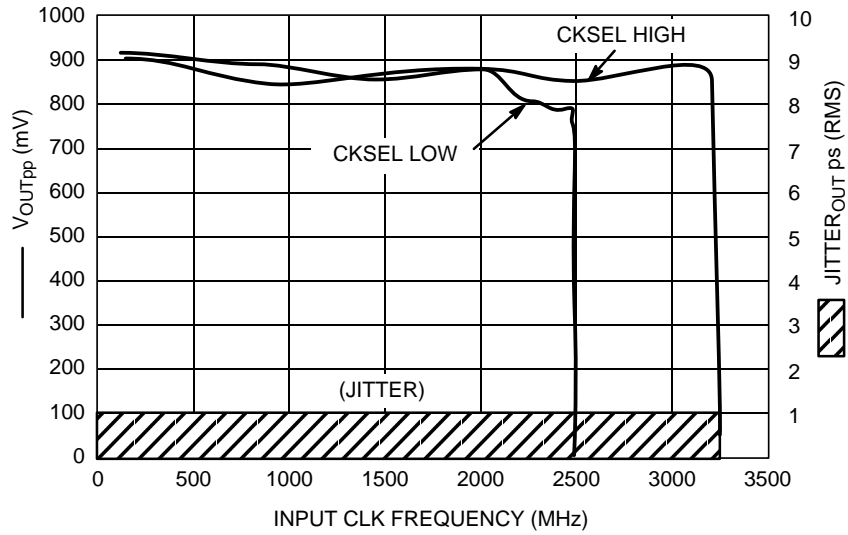

Figure 13. $F_{max}/Jitter$

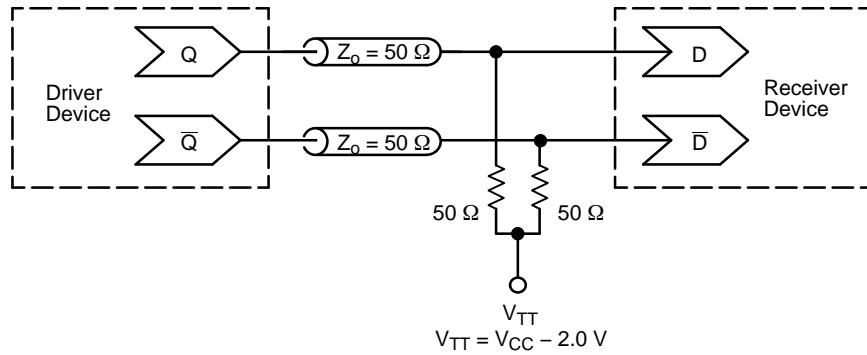

Figure 14. Typical Termination for Output Driver and Device Evaluation
(See Application Note AND8020/D – Termination of ECL Logic Devices.)

MC10EP445, MC100EP445

ORDERING INFORMATION

Device	Package	Shipping†
MC10EP445FAG	LQFP-32 (Pb-Free)	250 Units / Tray
MC10EP445FAR2G		2000 / Tape & Reel
MC10EP445MNG	QFN-32 (Pb-Free)	74 Units / Rail
MC10EP445MNR4G		1000 / Tape & Reel
MC100EP445FAG	LQFP-32 (Pb-Free)	250 Units / Tray
MC100EP445FAR2G		2000 / Tape & Reel
MC100EP445MNG	QFN-32 (Pb-Free)	74 Units / Rail
MC100EP445MNR4G		1000 / Tape & Reel

†For information on tape and reel specifications, including part orientation and tape sizes, please refer to our Tape and Reel Packaging Specifications Brochure, BRD8011/D.

Resource Reference of Application Notes

- AN1405/D** – ECL Clock Distribution Techniques
- AN1406/D** – Designing with PECL (ECL at +5.0 V)
- AN1503/D** – ECLinPS™ I/O SPICE Modeling Kit
- AN1504/D** – Metastability and the ECLinPS Family
- AN1568/D** – Interfacing Between LVDS and ECL
- AN1672/D** – The ECL Translator Guide
- AND8001/D** – Odd Number Counters Design
- AND8002/D** – Marking and Date Codes
- AND8020/D** – Termination of ECL Logic Devices
- AND8066/D** – Interfacing with ECLinPS
- AND8090/D** – AC Characteristics of ECL Devices

MC10EP445, MC100EP445

PACKAGE DIMENSIONS

32 LEAD LQFP
CASE 873A-02
ISSUE C

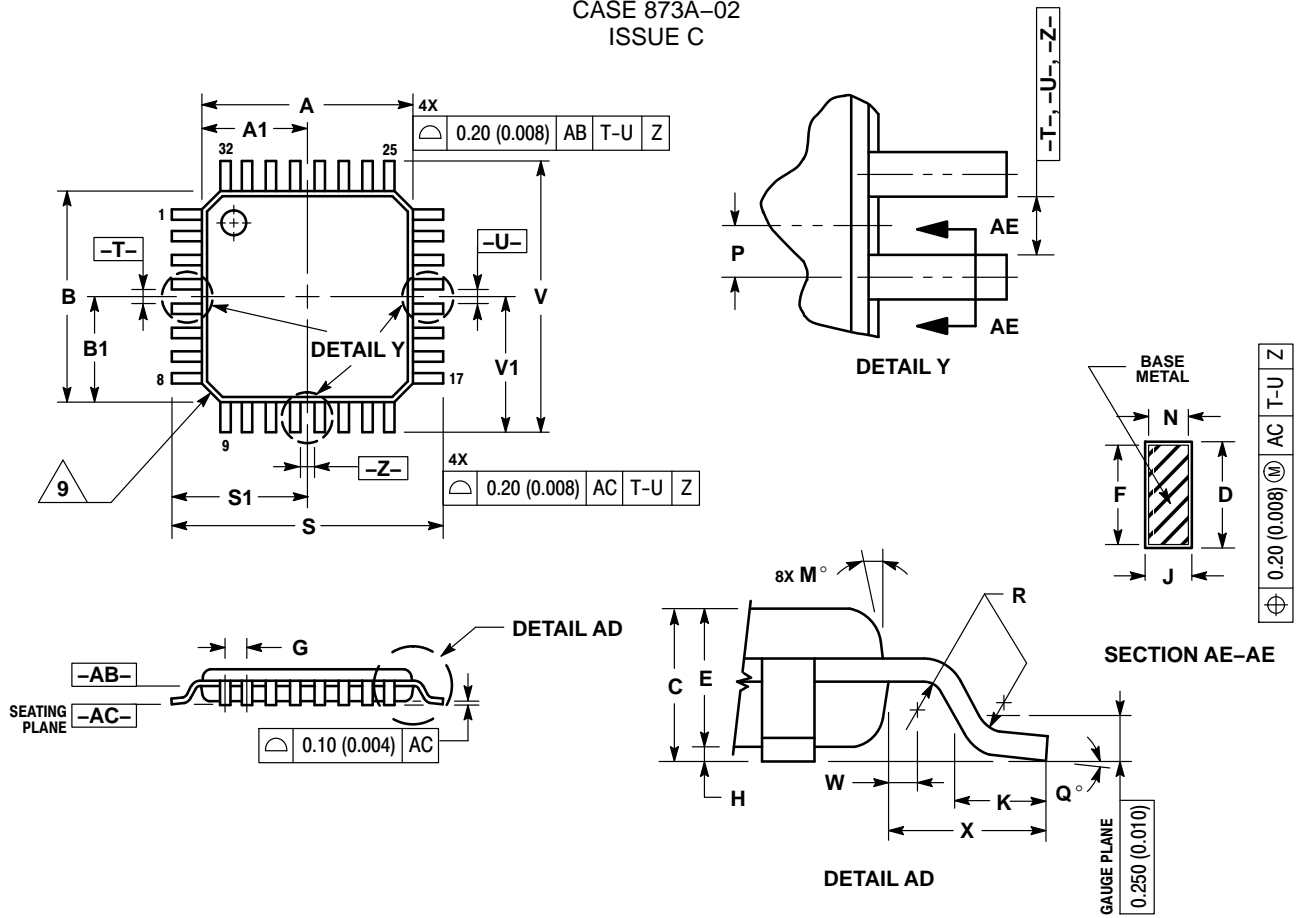

NOTES:

1. DIMENSIONING AND TOLERANCING PER ANSI Y14.5M, 1982.
2. CONTROLLING DIMENSION: MILLIMETER.
3. DATUM PLANE -AB- IS LOCATED AT BOTTOM OF LEAD AND IS COINCIDENT WITH THE LEAD WHERE THE LEAD EXITS THE PLASTIC BODY AT THE BOTTOM OF THE PARTING LINE.
4. DATUMS -T-, -U-, AND -Z- TO BE DETERMINED AT DATUM PLANE -AB-.
5. DIMENSIONS S AND V TO BE DETERMINED AT SEATING PLANE -AC-.
6. DIMENSIONS A AND B DO NOT INCLUDE MOLD PROTRUSION. ALLOWABLE PROTRUSION IS 0.250 (0.010) PER SIDE. DIMENSIONS A AND B DO INCLUDE MOLD MISMATCH AND ARE DETERMINED AT DATUM PLANE -AB-.
7. DIMENSION D DOES NOT INCLUDE DAMBAR PROTRUSION. DAMBAR PROTRUSION SHALL NOT CAUSE THE D DIMENSION TO EXCEED 0.520 (0.020).
8. MINIMUM SOLDER PLATE THICKNESS SHALL BE 0.0076 (0.0003).
9. EXACT SHAPE OF EACH CORNER MAY VARY FROM DEPICTION.

DIM	MILLIMETERS		INCHES	
	MIN	MAX	MIN	MAX
A	7.000	BSC	0.276	BSC
A1	3.500	BSC	0.138	BSC
B	7.000	BSC	0.276	BSC
B1	3.500	BSC	0.138	BSC
C	1.400	1.600	0.055	0.063
D	0.300	0.450	0.012	0.018
E	1.350	1.450	0.053	0.057
F	0.300	0.400	0.012	0.016
G	0.800	BSC	0.031	BSC
H	0.050	0.150	0.002	0.006
J	0.090	0.200	0.004	0.008
K	0.450	0.750	0.018	0.030
M	12°	REF	12°	REF
N	0.090	0.160	0.004	0.006
P	0.400	BSC	0.016	BSC
Q	1°	5°	1°	5°
R	0.150	0.250	0.006	0.010
S	9.000	BSC	0.354	BSC
S1	4.500	BSC	0.177	BSC
V	9.000	BSC	0.354	BSC
V1	4.500	BSC	0.177	BSC
W	0.200	REF	0.008	REF
X	1.000	REF	0.039	REF

MC10EP445, MC100EP445

PACKAGE DIMENSIONS

QFN32 5x5, 0.5P
CASE 488AM
ISSUE A

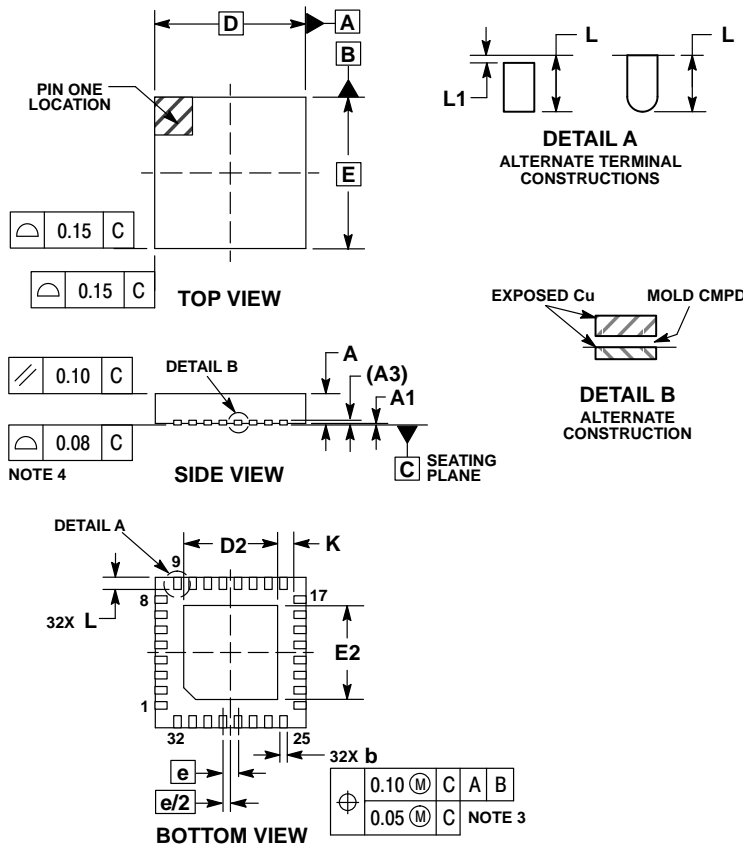

NOTES:

1. DIMENSIONS AND TOLERANCING PER ASME Y14.5M, 1994.
2. CONTROLLING DIMENSION: MILLIMETERS.
3. DIMENSION b APPLIES TO PLATED TERMINAL AND IS MEASURED BETWEEN 0.15 AND 0.30MM FROM THE TERMINAL TIP.
4. COPLANARITY APPLIES TO THE EXPOSED PAD AS WELL AS THE TERMINALS.

DIM	MILLIMETERS	
	MIN	MAX
A	0.80	1.00
A1	---	0.05
A3	0.20 REF	
b	0.18	0.30
D	5.00 BSC	
D2	2.95	3.25
E	5.00 BSC	
E2	2.95	3.25
e	0.50 BSC	
K	0.20	---
L	0.30	0.50
L1	---	0.15

RECOMMENDED SOLDERING FOOTPRINT*

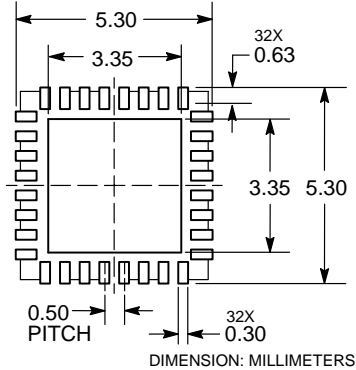

*For additional information on our Pb-Free strategy and soldering details, please download the ON Semiconductor Soldering and Mounting Techniques Reference Manual, SOLDERRM/D.

ECLinPS is a trademark of Semiconductor Components Industries, LLC (SCILLC)

ON Semiconductor and  are registered trademarks of Semiconductor Components Industries, LLC (SCILLC). SCILLC owns the rights to a number of patents, trademarks, copyrights, trade secrets, and other intellectual property. A listing of SCILLC's product/patent coverage may be accessed at www.onsemi.com/site/pdf/Patent-Marking.pdf. SCILLC reserves the right to make changes without further notice to any products herein. SCILLC makes no warranty, representation or guarantee regarding the suitability of its products for any particular purpose, nor does SCILLC assume any liability arising out of the application or use of any product or circuit, and specifically disclaims any and all liability, including without limitation special, consequential or incidental damages. "Typical" parameters which may be provided in SCILLC data sheets and/or specifications can and do vary in different applications and actual performance may vary over time. All operating parameters, including "Typicals" must be validated for each customer application by customer's technical experts. SCILLC does not convey any license under its patent rights nor the rights of others. SCILLC products are not designed, intended, or authorized for use as components in systems intended for surgical implant into the body, or other applications intended to support or sustain life, or for any other application in which the failure of the SCILLC product could create a situation where personal injury or death may occur. Should Buyer purchase or use SCILLC products for any such unintended or unauthorized application, Buyer shall indemnify and hold SCILLC and its officers, employees, subsidiaries, affiliates, and distributors harmless against all claims, costs, damages, and expenses, and reasonable attorney fees arising out of, directly or indirectly, any claim of personal injury or death associated with such unintended or unauthorized use, even if such claim alleges that SCILLC was negligent regarding the design or manufacture of the part. SCILLC is an Equal Opportunity/Affirmative Action Employer. This literature is subject to all applicable copyright laws and is not for resale in any manner.

PUBLICATION ORDERING INFORMATION

LITERATURE FULFILLMENT:
Literature Distribution Center for ON Semiconductor
P.O. Box 5163, Denver, Colorado 80217 USA
Phone: 303-675-2175 or 800-344-3860 Toll Free USA/Canada
Fax: 303-675-2176 or 800-344-3867 Toll Free USA/Canada
Email: orderlit@onsemi.com

N. American Technical Support: 800-282-9855 Toll Free
USA/Canada
Europe, Middle East and Africa Technical Support:
Phone: 421 33 790 2910
Japan Customer Focus Center
Phone: 81-3-5817-1050

ON Semiconductor Website: www.onsemi.com
Order Literature: <http://www.onsemi.com/orderlit>

For additional information, please contact your local Sales Representative

Looking for pricing, stock, or lifecycle information?

Click below to explore more details on WIN SOURCE:

 [View MC100EP445FAR2 on WIN SOURCE](#)

 [ON Semiconductor](#) Information

Optimize Your Supply Chain with WIN SOURCE Solutions

-  Global Sourcing Solution
-  Obsolete Management
-  Cost Control Management
-  Shortage Management
-  Alternative Solution
-  Excess Inventory Management