

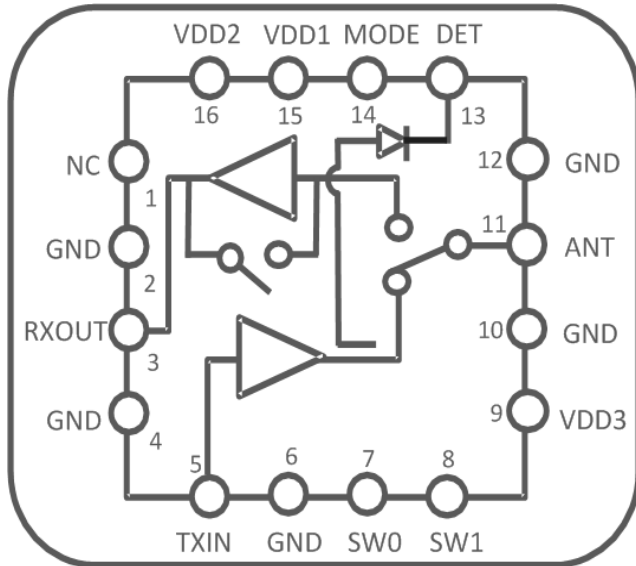

THE DATASHEET OF RFX5000B



5GHZ TRANSMIT / RECEIVE WLAN CMOS RFEIC



Description

RFX5000B is a fully integrated, single-chip, single-die RFEIC (RF Front-end Integrated Circuit) which incorporates all the RF functionality needed for a typical IEEE 802.11a/n WLAN system operating in the 4.9-5.85GHz range. The RFX5000B architecture integrates the PA, LNA, Transmit and Receive switching circuitry, the associated matching network, and the harmonic filter all in a CMOS single-chip device. Combining superior performance, high sensitivity and efficiency, low noise, small form factor, and low cost, the RFX5000B is the ideal solution for single antenna applications, and the ideal building block for 802.11n MIMO applications for wireless HDTV and other high-performance video streaming solutions.

RFX5000B has simple and low-voltage CMOS control logic, and requires minimal external components including only the external power supply bypass and the desired band-pass filter for the receive path. A directional coupler based power detect circuit is also integrated for accurate monitoring of output power from the PA.

Applications

- ▶ 802.11a/n Access Point
- ▶ 802.11a/n Multimedia Applications
- ▶ 802.11a/n NIC PC Card
- ▶ 802.11n Mobile Platforms
- ▶ 802.11a Devices
- ▶ Other 5GHz Transceivers

FEATURES

- ▶ 5GHz WLAN Single Chip, Single-Die RF Front-End IC
- ▶ Separate TX and RX Transceiver Port and Single Antenna Port
- ▶ 5GHz Power Amplifier with Low-Pass Harmonic Filter
- ▶ Low Noise Amplifier with Bypass
- ▶ Transmit/Receive Switch Circuitry
- ▶ High Transmit Signal Linearity Meeting Standards for OFDM Modulation
- ▶ Integrated Power Detector for Transmit Power Monitor and Control
- ▶ Low Voltage (1.2V) CMOS Control Logic
- ▶ ESD Protection Circuitry on All Pins
- ▶ DC Decoupled RF Ports
- ▶ Internal RF Decoupling on All VDD Bias Pins
- ▶ Low Noise Figure for the Receive Channel
- ▶ High Power Capability for Received Signals
- ▶ Very Low DC Power Consumption
- ▶ Full On-chip Matching and Decoupling Circuitry
- ▶ Minimal External Components Required
- ▶ 50-Ohm Input/Output Matching
- ▶ Market Proven CMOS Technology
- ▶ 3.0mm x 3.0mm x 0.55mm Small Outline 16L QFN Package with Exposed Ground Pad

PIN ASSIGNMENTS:

Pin Number	Pin Name	Description
1	NC	Internally Not Connected
3	RXOUT	RF RX Output Port to the Transceiver; DC Shorted to GND
5	TXIN	RF TX Signal Input Port from the Transceiver; DC Shorted to GND
7	SW0	CMOS Input to Control Antenna Switch
8	SW1	CMOS Input to Control Antenna Switch
9	VDD3	DC Supply Voltage
11	ANT	RF Signal from the PA or RF Signal to the LNA; DC Shorted to GND
13	DET	Analog Voltage Proportional to the PA Power Output
14	MODE	CMOS Input to Control High Linearity/Low Current Mode
15	VDD1	DC Supply Voltage
16	VDD2	DC Supply Voltage
2, 4, 6, 10, 12, 17	GND	Ground – Must be connected to GND

PIN-OUT DIAGRAM:

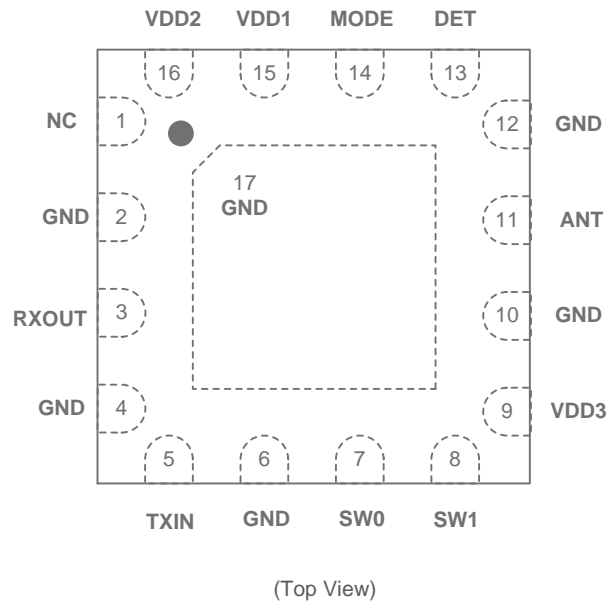

ABSOLUTE MAXIMUM RATINGS:

Parameters	Units	Min	Max	Conditions
DC VDD Voltage Supply	V	0	4.0	All VDD Pins
DC Control Pin Voltage	V	0	VDD	All Control Pins
DC VDD Current Consumption	mA		350	Through VDD Pins when TX PA is "ON"
TX RF Input Power	dBm		+10	
ANT RF Input Power	dBm		+10	
Junction Temperature	°C		150	
Storage Ambient Temperature	°C	-40	+150	Appropriate care required according to JEDEC Standards
Operating Ambient Temperature	°C	-40	+85	

Note: Sustained operation at or above the Absolute Maximum Ratings for any one or combinations of the above parameters may result in permanent damage to the device and is not recommended. All Maximum RF Input Power Ratings assume 50-Ohm terminal impedance.

RECOMENDED OPERATING CONDITIONS:

Parameters	Units	Min	Typ	Max	Conditions
DC VDD Voltage Supply (Note 1)	V	2.7	3.3	3.6	All VDD Pins
Control Voltage "High"	V	1.2		VDD	
Control Voltage "Low"	V	0		0.3	
DC Control Pin Current Consumption	µA		1		
DC Shutdown Current	µA		7		
PA Turn On/Off Time	µsec		0.5	1	
LNA Turn On/Off Time	µsec		0.5	1	
Shut-Down and "ON" State Switching Time	µsec		0.5	1	

Note 1: For normal operation of the RFX5000B, VDD must be continuously applied to all VDD supply pins.

TRANSMIT TECHNICAL PARAMETERS (VDD=3.3V; T=+25 °C)

Parameters	Units	Min	Typ	Max	Conditions
Operating Frequency Band	GHz	4.9		5.85	
Linear Output Power for EVM<3%, 802.11a 64QAM/54Mbps;	dBm	+16	+17		High Linearity Mode
			+15		Low Current Mode
Small-Signal Power Gain in All Modes	dB	28	32		High Linearity Mode
		26	30		Low Current Mode
TX Quiescent Current	mA		135		High Linearity Mode
			100		Low Current Mode
TX Linear Current	mA		200		P _{OUT} = +17dBm, High Linearity Mode
			160		P _{OUT} = +15dBm, Low Current Mode
Power Detector Voltage Output	mV	200		1000	P _{OUT} = +5 to +18dBm
Second Harmonic	dBc		-30		P _{OUT} =+17dBm, CW
Third Harmonic	dBc		-35		P _{OUT} =+17dBm, CW
Input Return Loss	dB		-10		
Output Return Loss	dB		-10		
Load VSWR for Stability (CW, Fix Pin for Pout=+20dBm with 50Ω load)	N/A	4:1	6:1		All non-harmonically related spurs less than -43dBm/MHz
Load VSWR for Ruggedness (CW, Fix Pin for Pout=+20dBm)			10:1		No Damage

RECEIVE TECHNICAL PARAMETERS (VDD=3.3V; T=+25 °C)

Parameters	Units	Min	Typ	Max	Conditions
Operating Frequency Band	GHz	4.9		5.85	All RF Pins are Loaded by 50-Ohm
Gain	dB		13		
Noise Figure	dB		3		
Insertion Loss for LNA Bypass Mode	dB		13		
Input Return Loss	dB		-10		
Output Return Loss	dB		-10		
RF Port Impedance	Ohm		50		
DC Quiescent Current	mA		14		P _{OUT} < -10dBm, through VDD
Input P _{1dB}	dBm		-3		At ANT Pin, RX "ON"

RFeIC® is a registered trademark of RFAxis, Inc. All rights reserved.

This product document is a general list of parameters to provide information on the capabilities of this device and is subject to change without notice.

PACKAGE DIMENSIONS:

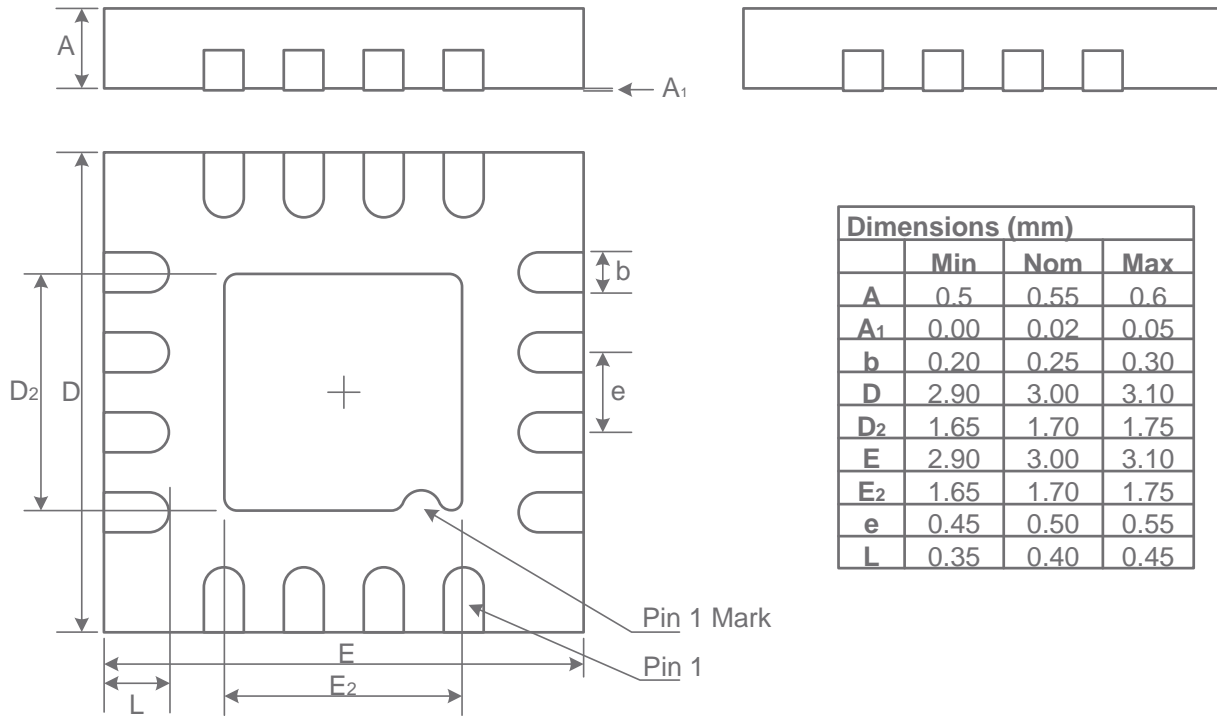

PACKAGE MARKING:

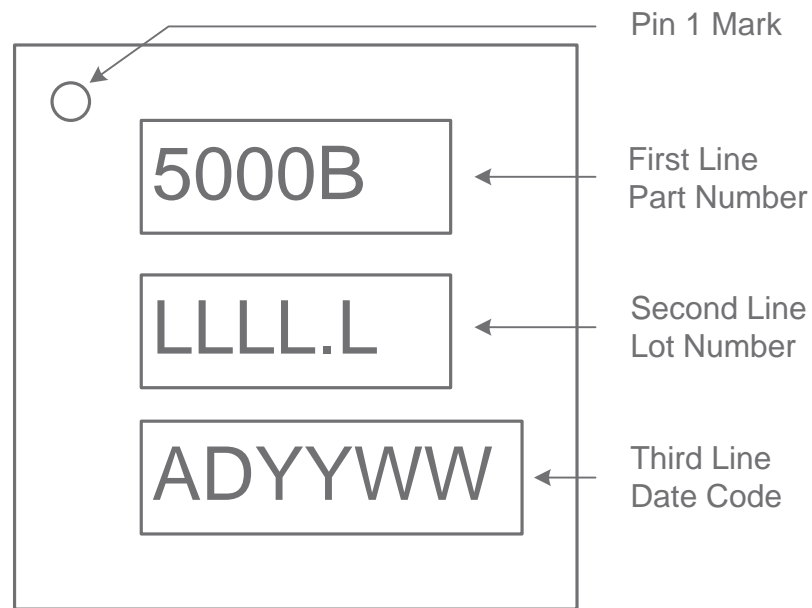

RFeIC® is a registered trademark of RFAxis, Inc. All rights reserved.

This product document is a general list of parameters to provide information on the capabilities of this device and is subject to change without notice.

TAPE AND REEL INFORMATION:

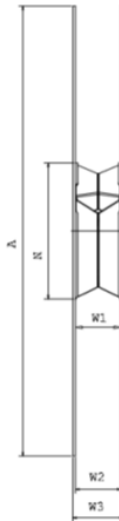
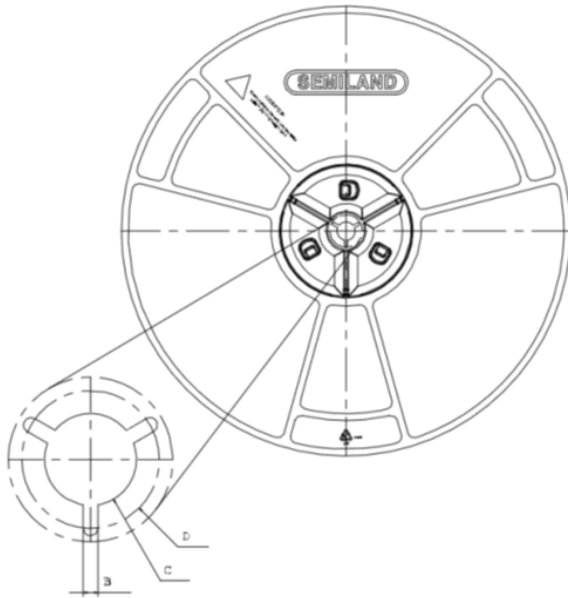
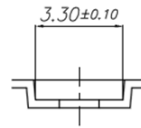
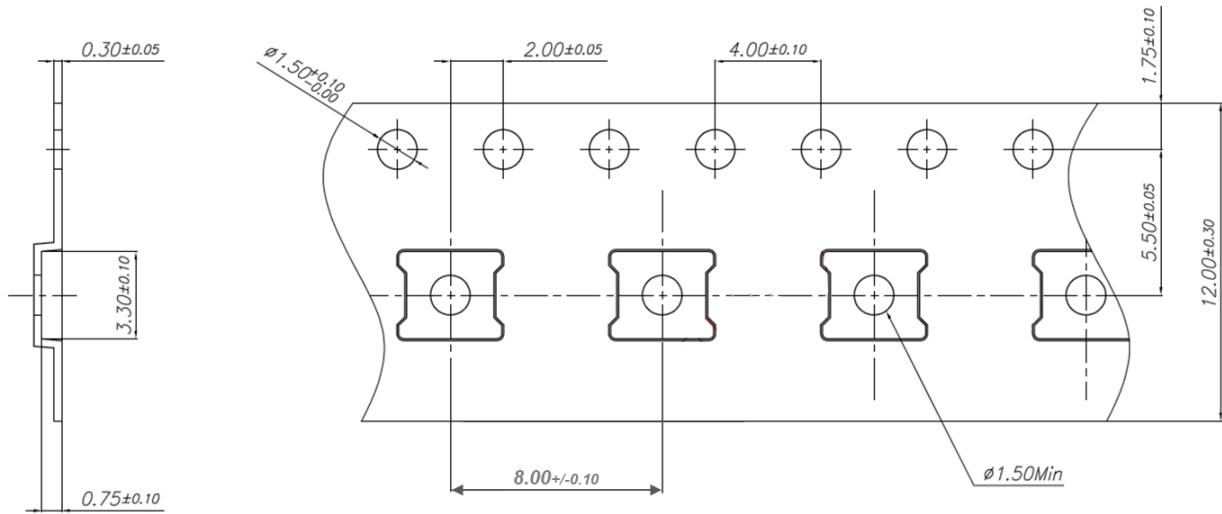

Size	12mm
A	330 ^{+0.2} _{-2.0}
B	1.5min
C	13.0 ^{+0.5} _{-0.2}
D	20.2min
N	100 ^{+2.0} _{-0.0}
W1	12.4 ^{+3.0} _{-0.0}
W2	12.4 ^{+3.0} _{-0.0}
W3	16.4 ^{+2.0} _{-2.0}
PART#	SRL-12134H

RFelC® is a registered trademark of RFAxis, Inc. All rights reserved.

This product document is a general list of parameters to provide information on the capabilities of this device and is subject to change without notice.

Looking for pricing, stock, or lifecycle information?

Click below to explore more details on WIN SOURCE:

- ⊖ [View RFX5000B on WIN SOURCE](#)
- ⊖ [Skyworks Solutions Inc. Information](#)

Optimize Your Supply Chain with WIN SOURCE Solutions

- ✓ Global Sourcing Solution
- ✓ Obsolete Management
- ✓ Cost Control Management
- ✓ Shortage Management
- ✓ Alternative Solution
- ✓ Excess Inventory Management