



**THE DATASHEET OF
ACMD-6207-TR1**



ACMD-6207

LTE Band 7 Duplexer with Balanced Rx Port



Data Sheet

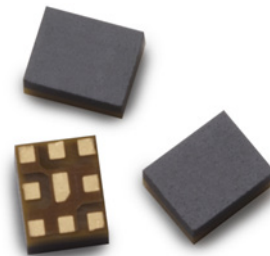

Description

The Avago ACMD-6207 is a highly miniaturized duplexer designed for use in LTE Band 7 (2500 – 2570 MHz UL, 2620 – 2690 MHz DL) handsets and mobile data terminals.

Low Insertion Loss in the Tx channel minimizes current drain from the power amplifier, while low Rx channel Insertion Loss improves receiver sensitivity. The Rx port is balanced to preserve CMR and simplify the interface to baseband chipsets.

The ACMD-6207 enhances the sensitivity and dynamic range of handset receivers by providing high isolation of the transmitted signal from the receiver input and high rejection of transmit-generated noise in the receive band.

The ACMD-6207 is designed with Avago Technologies' innovative Film Bulk Acoustic Resonator (FBAR) technology, which makes possible ultra-small, high-Q filters at a fraction of their usual size. The excellent power handling capability of FBAR bulk-mode resonators supports the high output power levels used in mobile communications applications, while adding virtually no distortion.

The ACMD-6207 also utilizes Avago Technologies' advanced Microcap bonded-wafer, chip scale packaging technology. This process allows the filters to be assembled into a molded chip-on-board module with an overall size of only 1.6 x 2.0 mm and maximum height of 0.90 mm. The ACMD-6207 is compatible with standard 1.6 x 2.0 mm duplexer PCB footprints.

Functional Block Diagram

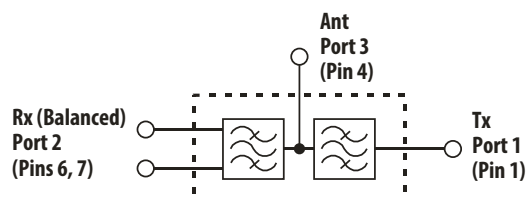

Features

- Miniature Size
 - 1.6 x 2.0 mm size
 - 0.9 mm height
 - Standard 1.6 x 2.0 mm PCB footprint
- Balanced Rx Port, 100 Ω
- No external matching required
- High Isolation
- High Power Rating
 - +31 dBm Abs Max Tx Power
- Environmental
 - RoHS Compliant
 - Halogen free
 - TBBPA Free

Specifications

- Rx Band Performance, 2620-2690 MHz, – 20 to +85°C
 - Insertion Loss: 3.0 dB Max
 - Rx Noise Blocking: 50 dB Min
- Tx Band Performance, 2500-2570 MHz, – 20 to +85°C
 - Insertion Loss: 3.0 dB Max
 - Tx Interferer Blocking: 55 dB Min

Applications

Handsets or data terminals operating in the Band 25 frequency range.

ACMD-6125 Electrical Specifications [2], $Z_0=50\ \Omega$, T_c [1] as indicated.

Symbol	Parameter	Units	- 20°C		+25°C		+85°C		
			Min	Max	Min	Typ [3]	Max	Min	Max
Antenna Port to Receive Port									
ZRx	Impedance of Balanced Rx Port, Real Part	Ohms				100			
S23	Insertion Loss in Receive Band 2620 – 2690 MHz	dB		3.0		1.8	3.0		3.0
ΔS_{23}	Amplitude Imbalance in Receive Band 2620 – 2690 MHz	dB		± 1.8		± 0.6	± 1.8		± 1.8
$\Delta S_{23\emptyset}$	Phase Imbalance in Receive Band 2620 – 2690 MHz	deg		± 8		± 5.1	± 8		± 8
S23	Attenuation in Transmit Band 2500 – 2570 MHz	dB	45		45	63		45	
S23	Attenuation, 50 – 2380 MHz	dB	40		40	63		40	
S23	Attenuation, 2380 – 2450 MHz (Wi-Fi Low)	dB	40		40	55		40	
S23	Attenuation, 2450 – 2484 MHz (Wi-Fi High)	dB	35		35	62		35	
S23	Attenuation, 2775 – 8500 MHz	dB	18		18	48		18	
S22	Return Loss (SWR) of Rx Port in Rx Band (100 Ω), 2620 – 2690 MHz	dB	9	(2.1)	9	20 (1.2)	(2.1)	9	(2.1)
S33	Return Loss (SWR) of Ant Port in Rx Band 2620 – 2690 MHz	dB	9	(2.1)	9	19 (1.3)	(2.1)	9	(2.1)
Transmit Port to Antenna Port									
S31	Insertion Loss in Transmit Band 2500 – 2510 MHz 2510 – 2570 MHz	dB		3.0 2.4		2.1 1.4	3.0 2.4		3.0 2.4
S31	Attenuation in Receive Band 2620 – 2690 MHz	dB	45		45	60		45	
S31	Attenuation, 50 – 1565 MHz	dB	45		45	61		45	
S31	Attenuation 1565 – 1574 MHz (GPS Low Band)	dB	45		45	48		45	
S31	Attenuation, 1574 – 1577 MHz (GPS L1 Band)	dB	45		45	48		45	
S31	Attenuation, 1577 – 1585 MHz (Wideband GPS High)	dB	45		45	48		45	
S31	Attenuation, 1597 – 1607 MHz (GLONASS)	dB	45		45	47		45	
S31	Attenuation, 1607 – 1680 MHz	dB	40		40	47		40	
S31	Attenuation, 1805 – 1880 MHz (Band 3 Rx)	dB	40		40	47		40	
S31	Attenuation, 2110 – 2170 MHz (Band 1 Rx)	dB	40		40	56		40	
S31	Attenuation, 2402.5 – 2461.5 MHz (Wi-Fi Bands 1 – 9)	dB	40		40	48		40	
S31	Attenuation, 2447.5 – 2481.5 MHz (Wi-Fi Bands 10 – 13)	dB	35		35	46		35	
S31	Attenuation in Tx 2nd Harmonic Band 5000 – 5140 MHz	dB	35		35	47		35	
S31	Attenuation, 5150 – 5850 MHz	dB	20		20	42		20	
S31	Attenuation, 7500 – 7710 MHz	dB	25		25	27		25	
S11	Return Loss (SWR) of Tx Port in Tx Band 2500 – 2570 MHz	dB	10	(1.9)	10	20 (1.2)	(1.9)	10	(1.9)
S33	Return Loss (SWR) of Ant Port in Tx Band 2500 – 2570 MHz	dB	10	(1.9)	10	20 (1.2)	(1.9)	10	(1.9)
Isolation Transmit Port to Receive Port									
S21	Tx-Rx Isolation in Receive Band 2620 – 2690 MHz	dB	50		50	60		50	
S21	Tx-Rx Differential Isolation in Transmit Band, 2500 – 2570 MHz	dB	55		55	61		55	
S21	Tx-Rx Common Mode Isolation in Transmit Band, 2500 – 2570 MHz	dB	55		55	60		55	

Notes:

1. T_c is the case temperature and is defined as the temperature of the underside of the Duplexer where it makes contact with the circuit board.
2. Min/Max specifications are guaranteed at the indicated temperature with the input power to the Tx port equal to or less than +27 dBm over all Tx frequencies unless otherwise noted.
3. Typical data is the average value of the parameter over the indicated band at the specified temperature. Typical values may vary over time.
4. Integrated Insertion Loss over any 1.25 MHz channel within the band.

Absolute Maximum Ratings^[1]

Parameter	Unit	Value
Storage temperature	°C	-65 to +125
Maximum RF Input Power to Tx Port	dBm	+31

Maximum Recommended Operating Conditions^[2]

Parameter	Unit	Value
Operating temperature, T _c ^[3] , Tx Power ≤ 29 dBm, CW	°C	-40 to +100
Operating temperature, T _c ^[3] , Tx Power ≤ 30 dBm, CW	°C	-40 to +85

Notes:

1. Operation in excess of any one of these conditions may result in permanent damage to the device.
2. The device will function over the recommended range without degradation in reliability or permanent change in performance, but is not guaranteed to meet electrical specifications.
3. T_c is defined as case temperature, the temperature of the underside of the duplexer where it makes contact with the circuit board.

ACMD-6207 Typical Performance at $T_c = 25^\circ$, Rx $Z_0 = 100 \Omega$, all other $Z_0 = 50 \Omega$

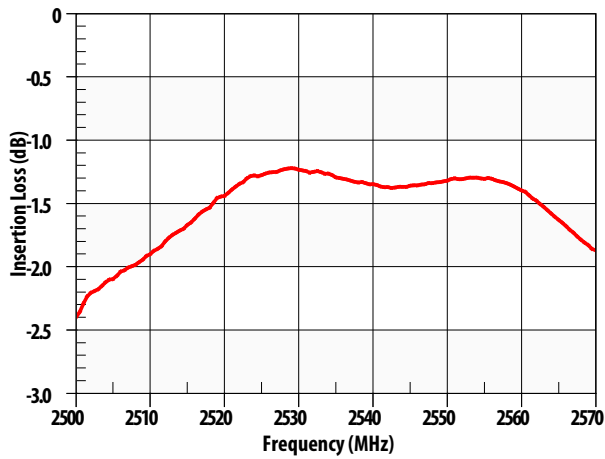

Figure 1. Tx-Ant Insertion Loss.

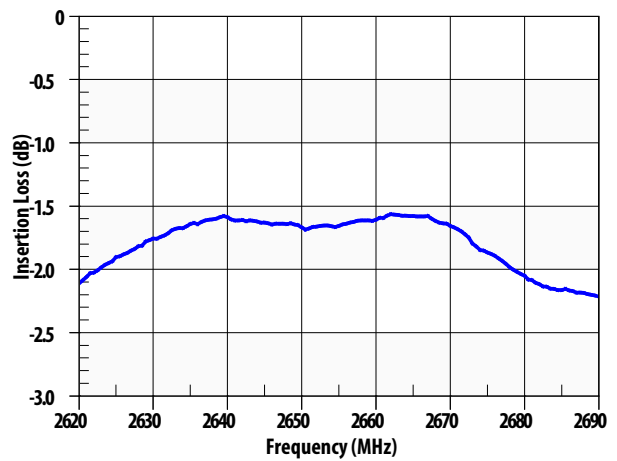

Figure 2. Ant-Rx Insertion Loss.

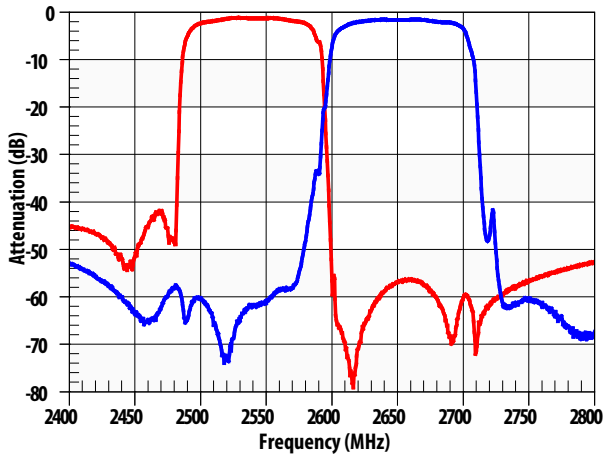

Figure 3. Tx Rejection in Rx Band and Rx Rejection in Tx Band.

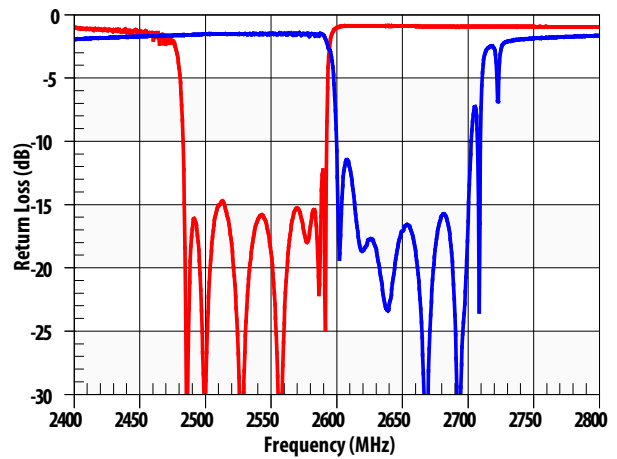

Figure 4. Tx and Rx Port Return Loss.

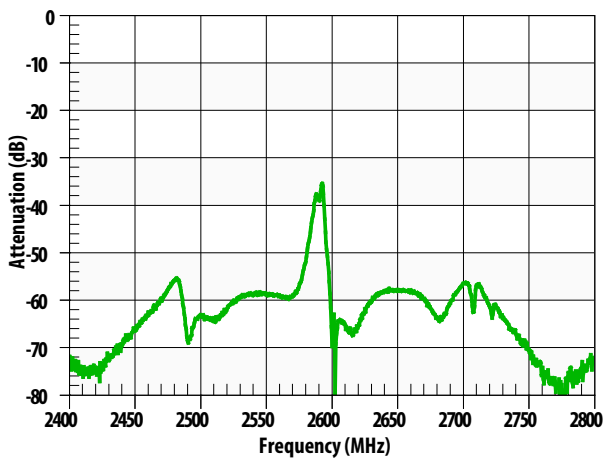

Figure 5. Tx-Rx Isolation.

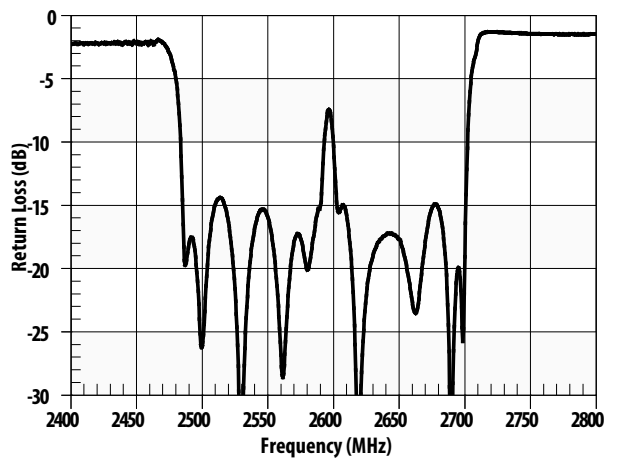

Figure 6. Antenna Port Return Loss.

ACMD-6207 Typical Performance at $T_c = 25^\circ$, Rx $Z_0 = 100 \Omega$, all other $Z_0 = 50 \Omega$

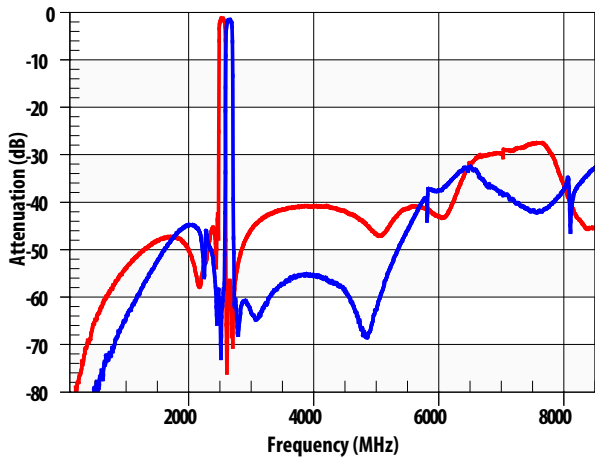

Figure 7. Tx-Ant and Ant-Rx Wideband Insertion Loss, 100 – 8500 MHz

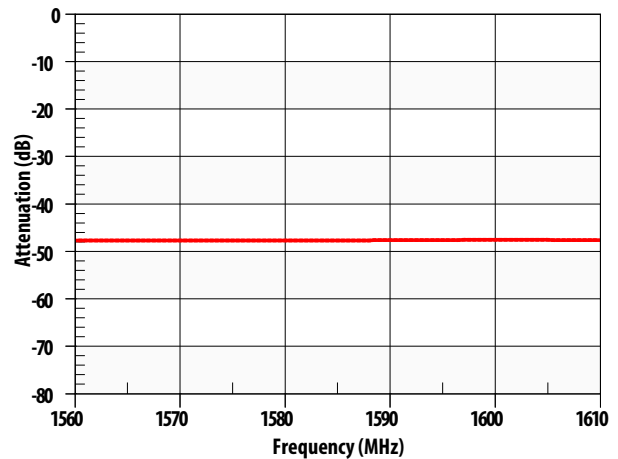

Figure 8. Tx-Ant Rejection in GPS/GLONASS Bands.

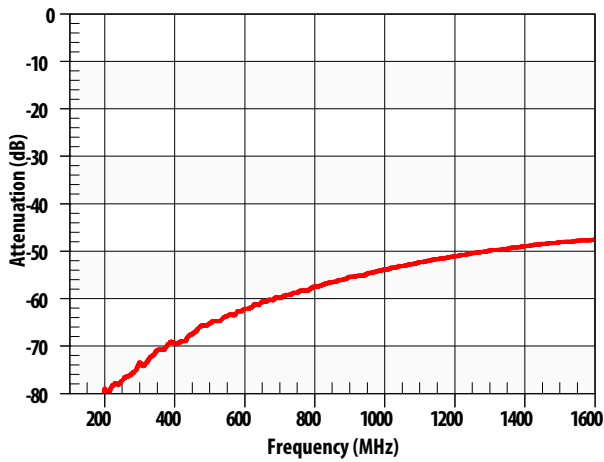

Figure 9. Tx-Ant Low Frequency Rejection, 100 – 1600 MHz

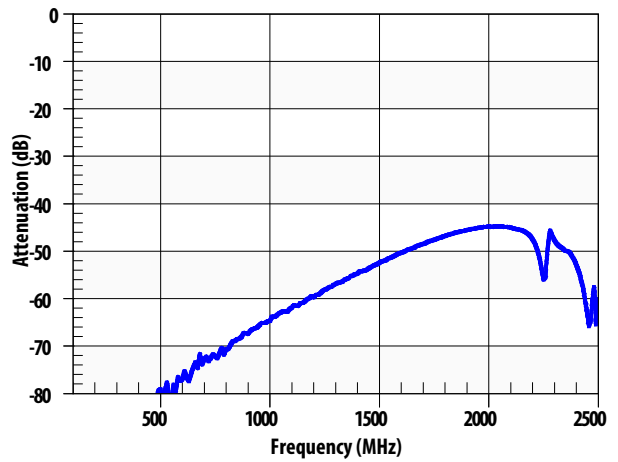

Figure 10. Ant-Rx Low Frequency Rejection, 100 – 2500 MHz

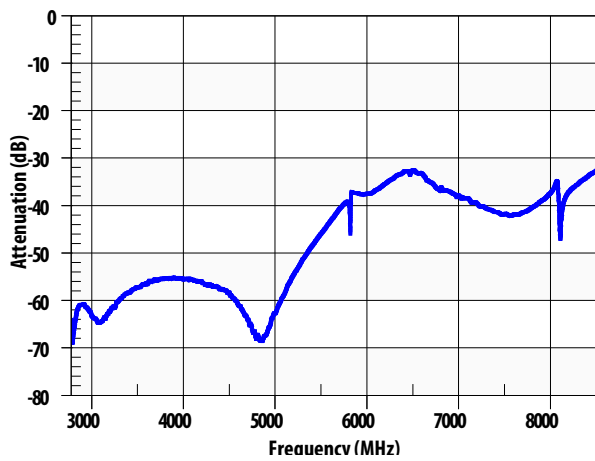

Figure 11. Ant-Rx Rejection, 2775 – 8500.

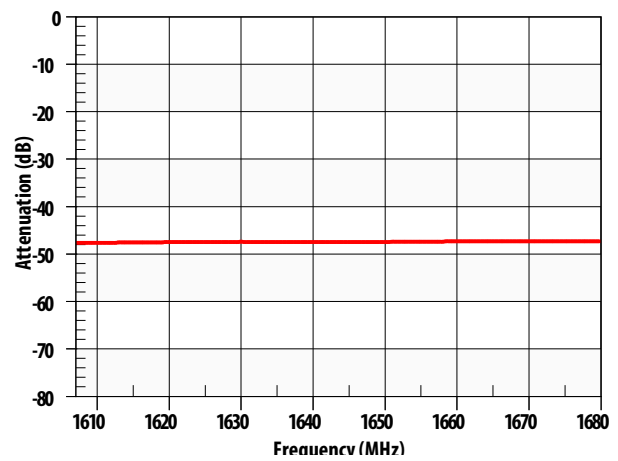

Figure 12. Tx-Ant Rejection, 1607 – 1680 MHz

ACMD-6207 Typical Performance at $T_c = 25^\circ$, Rx $Z_0 = 100 \Omega$, all other $Z_0 = 50 \Omega$

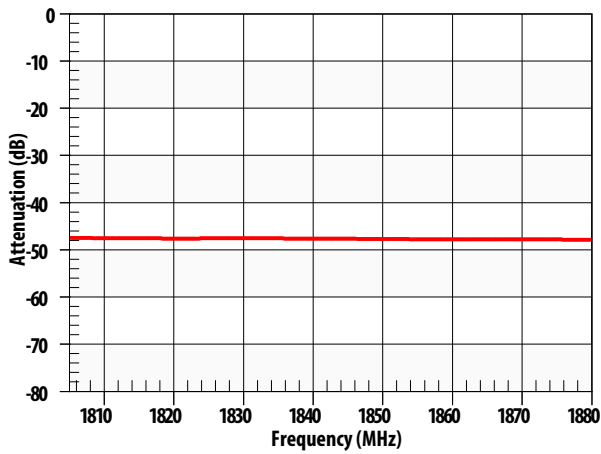

Figure 13. Tx-Ant Rejection, 1805 – 1880 MHz

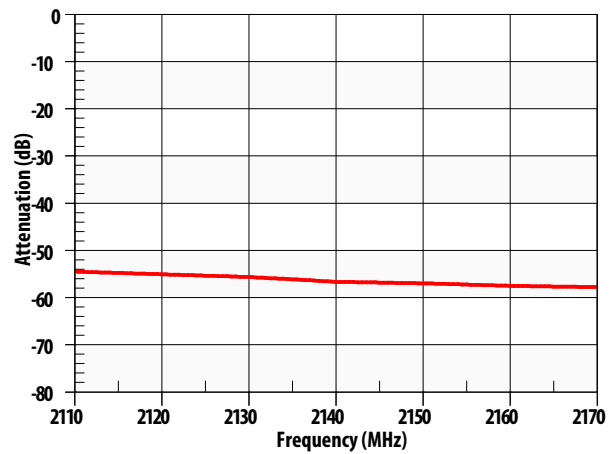

Figure 14. Tx-Ant Rejection, 2110 – 2170 MHz

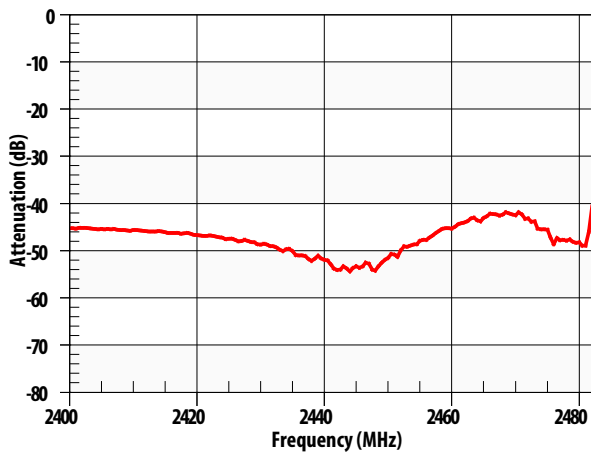

Figure 15. Tx-Ant Rejection in Wi-Fi Bands, 2400 – 2482 MHz

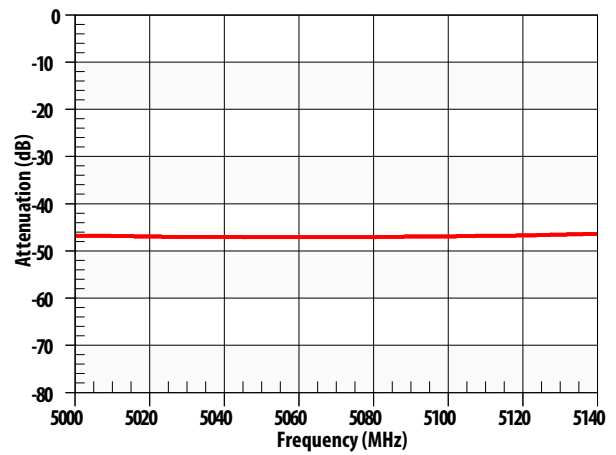

Figure 16. Tx-Ant Rejection at Tx 2nd Harmonic, 5000 – 5140 MHz

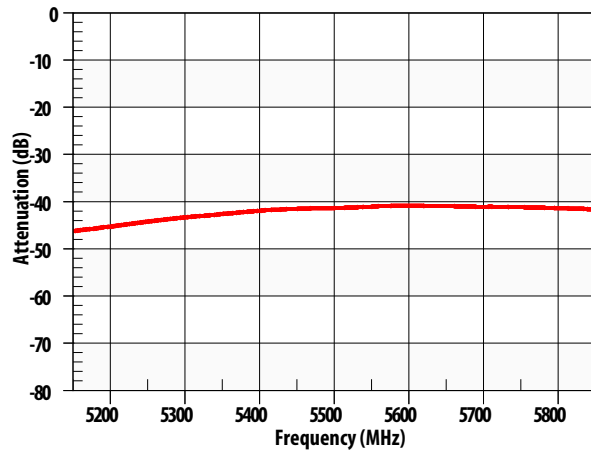

Figure 17. Tx-Ant Rejection, 5150 – 5850 MHz

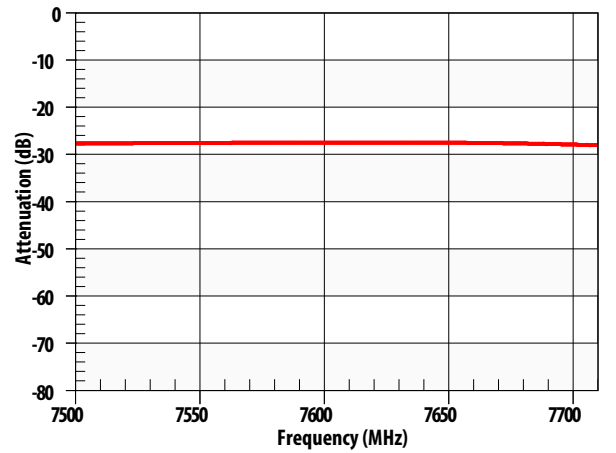

Figure 18. Tx-Ant Rejection, 7500 – 7710 MHz

ACMD-6207 Typical Performance at $T_c = 25^\circ$, Rx $Z_0 = 100 \Omega$, all other $Z_0 = 50 \Omega$

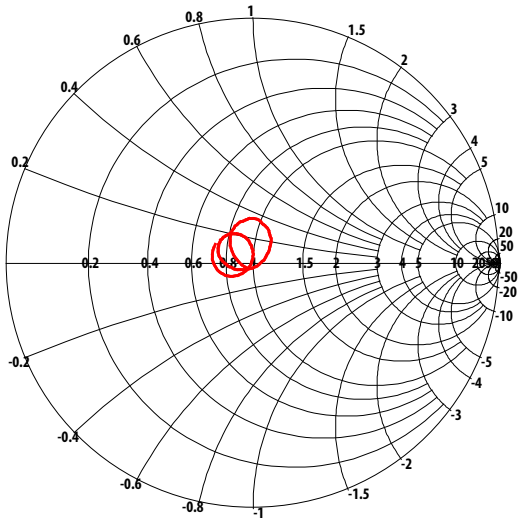

Figure 19. Tx Port Impedance in Tx Band.

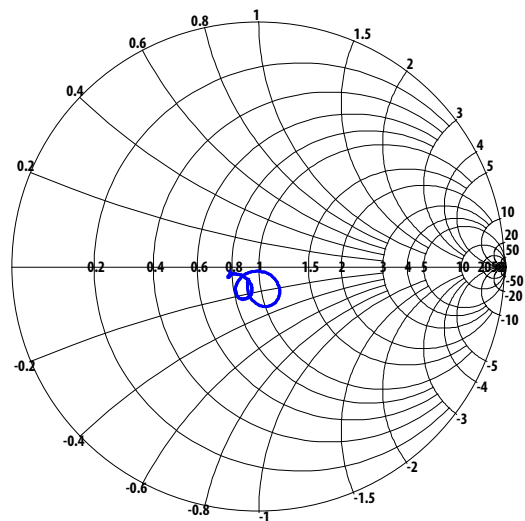

Figure 20. Rx Port Impedance in Rx Band ($Z_0 = 100$ ohms).

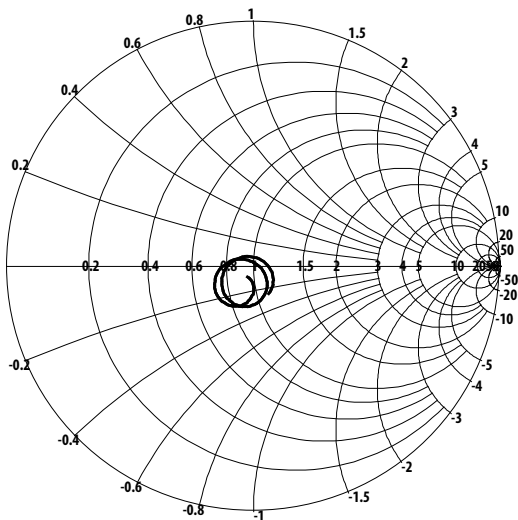

Figure 21. Ant Port Impedance in Tx Band.

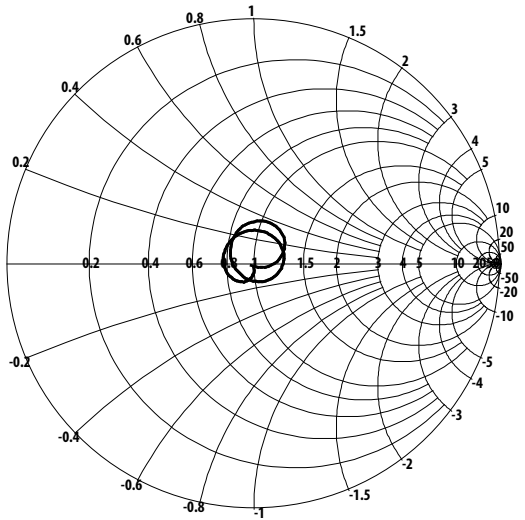
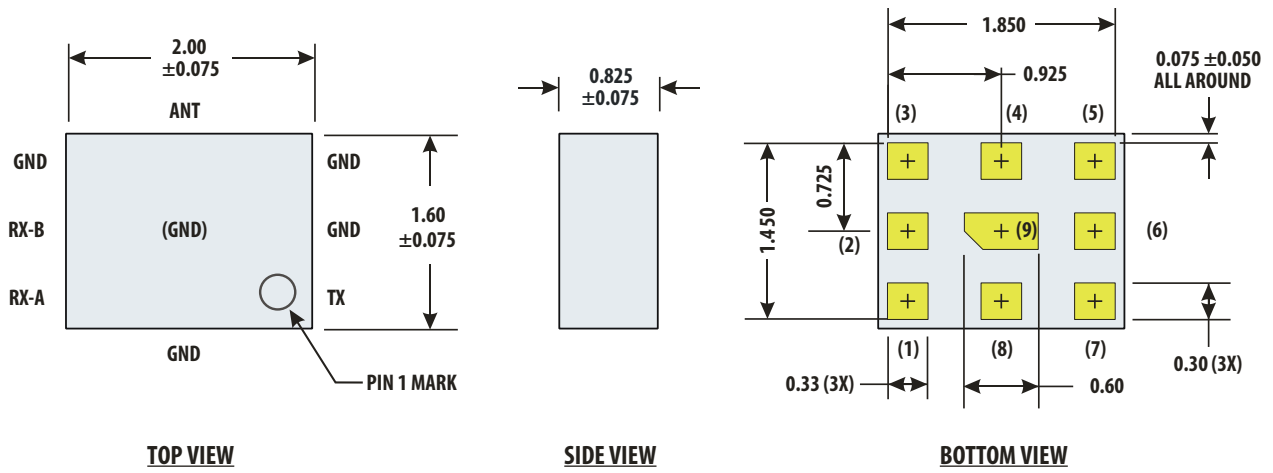

Figure 22. Ant Port Impedance in Rx Band.



- Notes:
1. Dimensions in millimeters
 2. Tolerance, unless otherwise noted:
X.XX ± 0.05 mm
X.XXX ± 0.025 mm
 3. Dimensions nominal unless otherwise noted
 4. Angles 45° nominal
 5. Contact areas are gold plated

- Pin Connections:
- | | |
|---------------|------|
| 1 | Tx |
| 4 | Ant |
| 6 | Rx-B |
| 7 | Rx-A |
| 2, 3, 5, 8, 9 | GND |

Figure 23. Package Outline Drawing

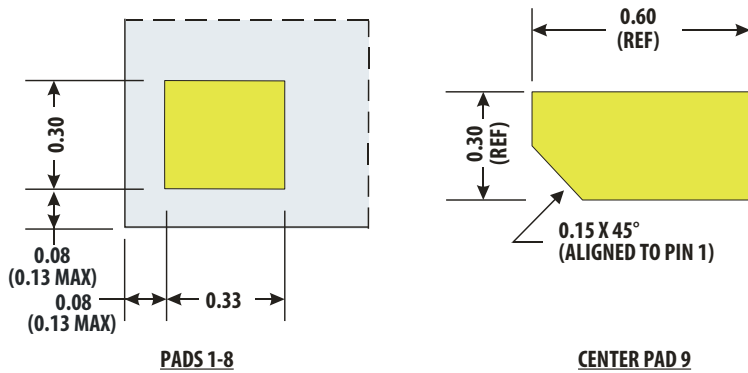
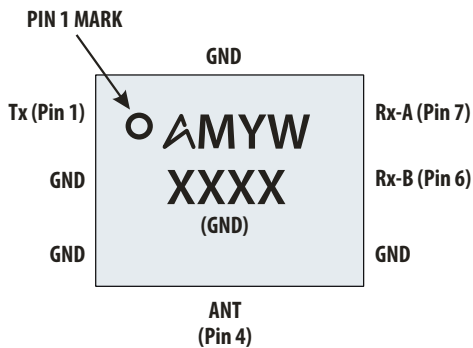

Figure 24. Pad Detail



“A” = Avago Technologies
M = ACMD-6207
Y = Year, last digit
W = Work Week *
XXXX = Lot Number

*Refer to Appendix A for Work Week Cross Reference

Figure 25. Product Marking and Pin Orientation

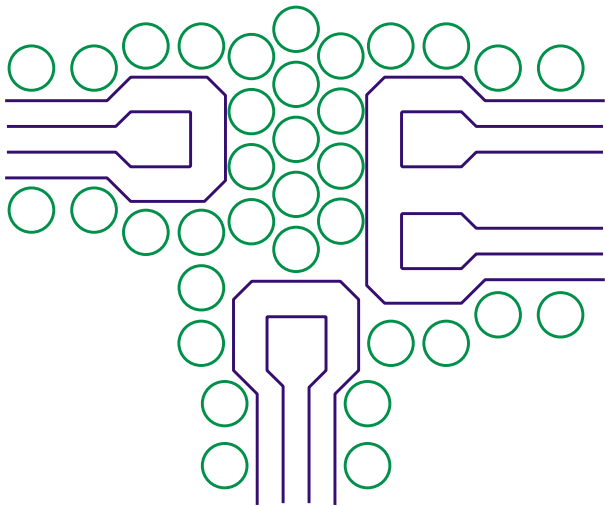

Figure 26. PCB Layout.

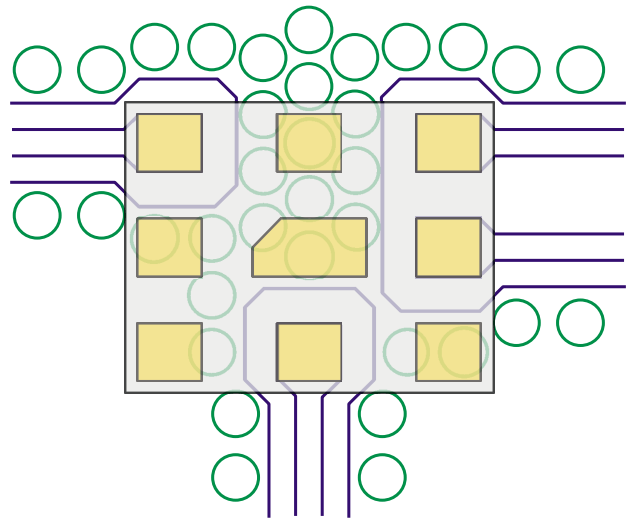

Figure 27. ACMD-6207 Superposed on PCB Pattern.

A circuit board layout using the principles illustrated in the figure above is recommended to optimize performance of the ACMD-6207.

It is important to maximize isolation between the Tx and Rx ports.

High isolation is achieved by: (1) maintaining a continuous ground plane around the I/O connections and duplexer mounting area, (2) surrounding the I/O ports with sufficient ground vias to enclose the connections in a "Faraday cage", and (3) preferably transitioning the balanced Rx traces to the 3rd metal layer.

The ground vias under the ACMD-6207 mounting area are also needed to provide adequate heat sinking for the device.

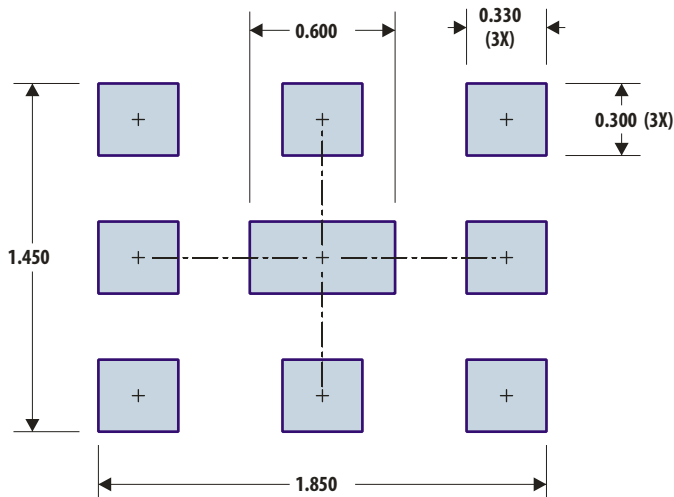

Notes:
1. Dimensions in mm

Figure 28. PCB Land Print.

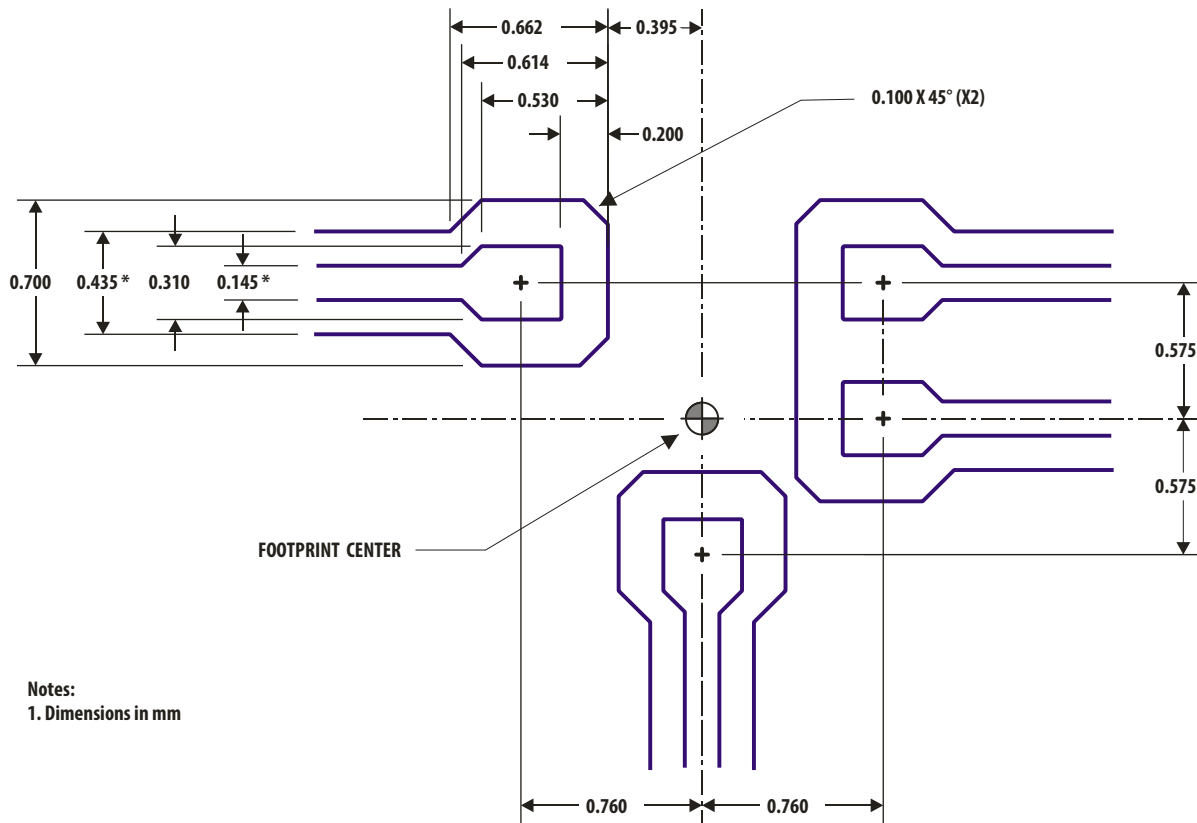

Figure 29. PCB Detail, Metal Dimensions.

The transmission line dimensions shown are designed to achieve an impedance of 50 ohms for a 75 μ m thick PCB layer with a dielectric constant of 3.4. If other PCB materials or thicknesses are used, the two dimensions indicated with an "*" (line width and spacing) can be adjusted to retain a Z_o of 50 ohms.

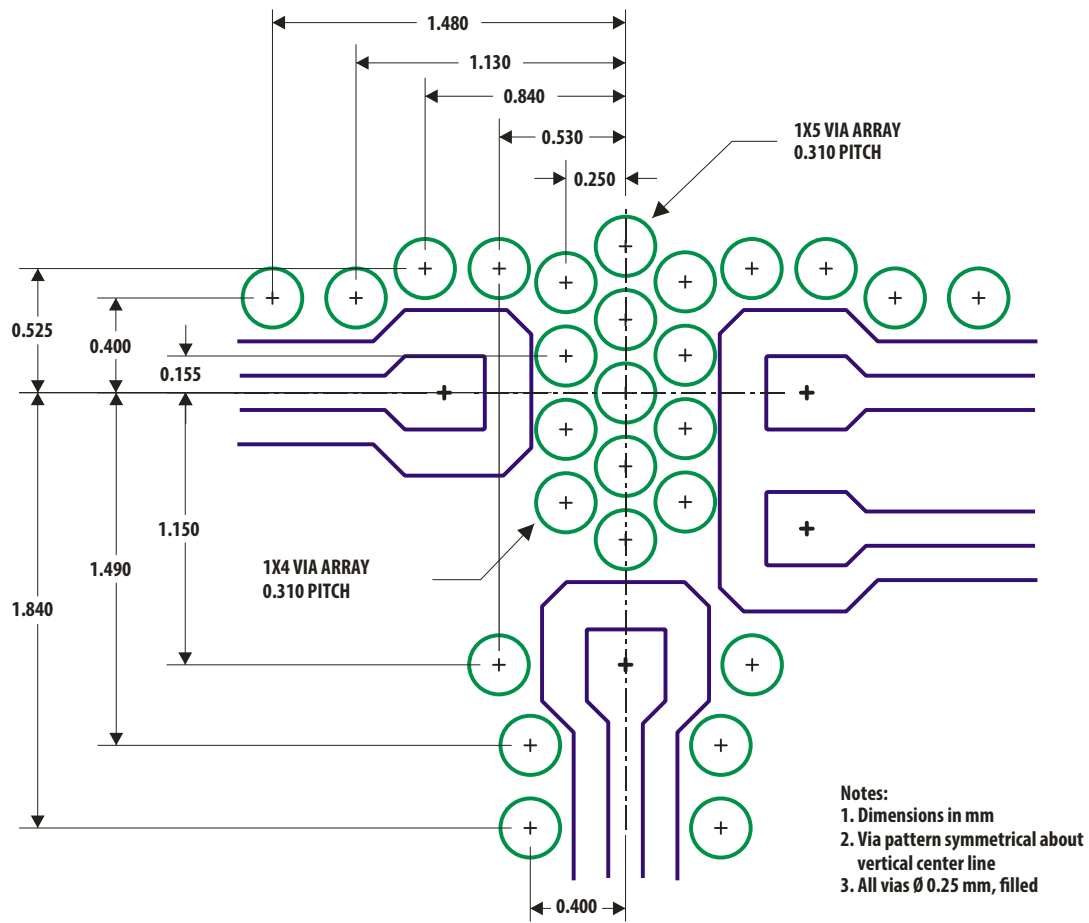

Figure 30. PCB Detail, Dimensions for Symmetrical Via Pattern.

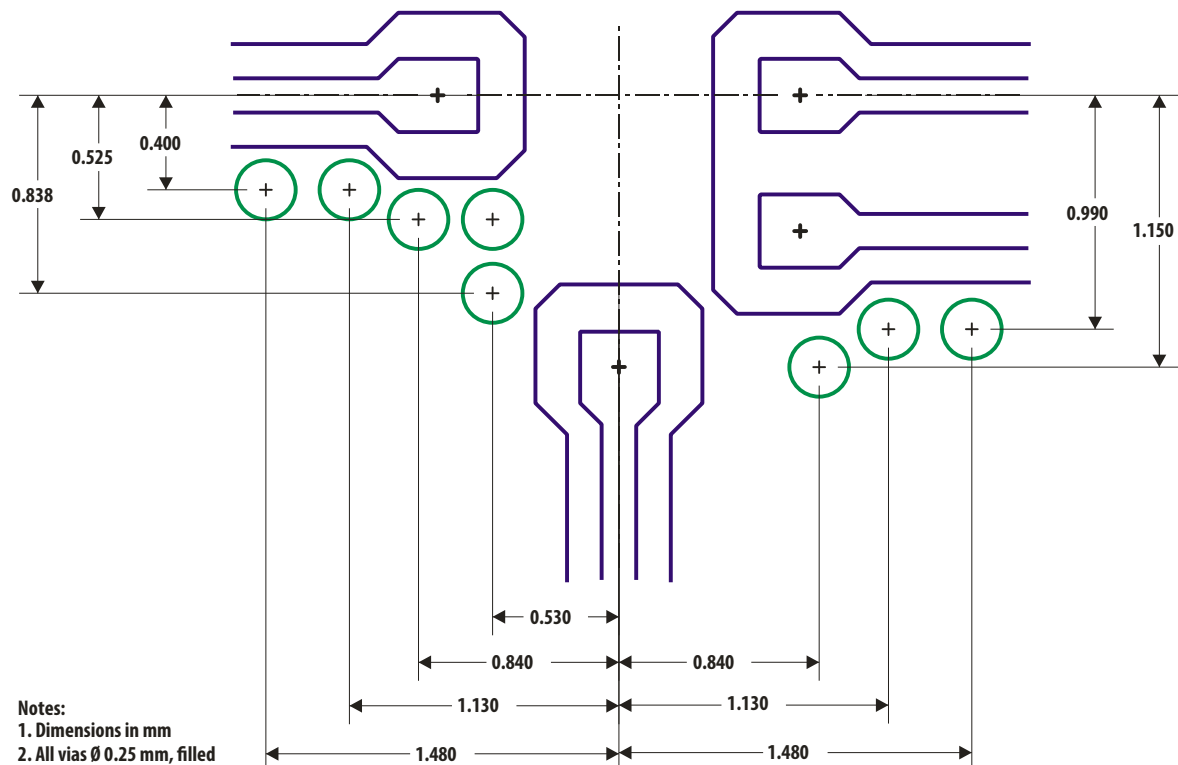

Figure 31. PCB Detail, Dimensions for Asymmetrical Via Pattern.

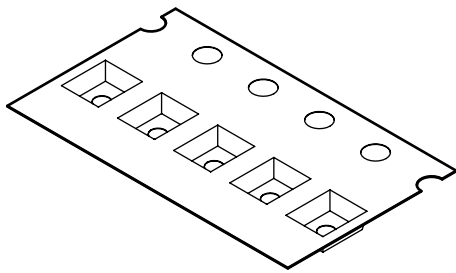
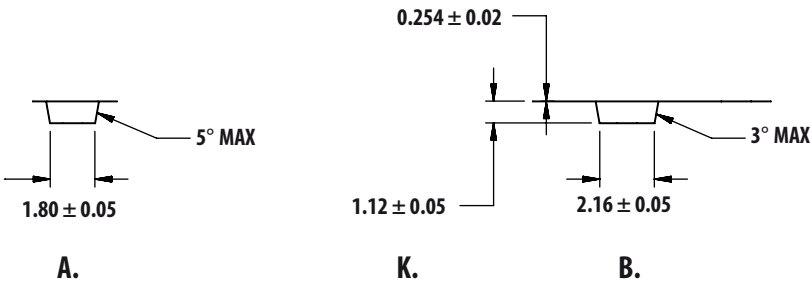
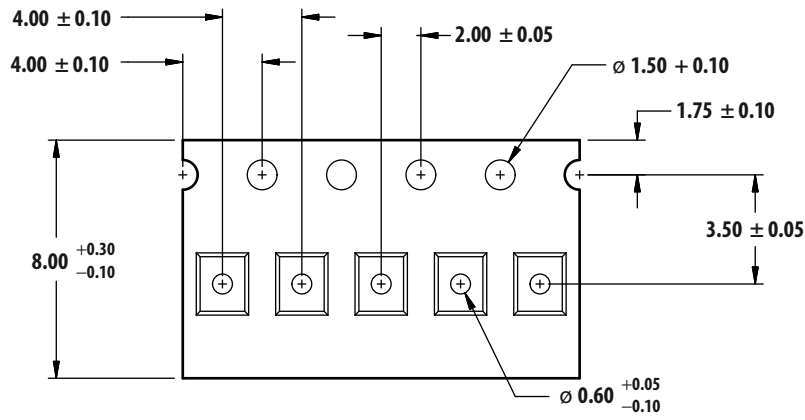

Figure 32. SMD Tape Packing

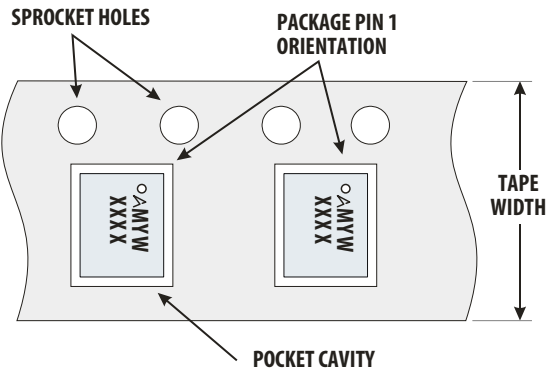
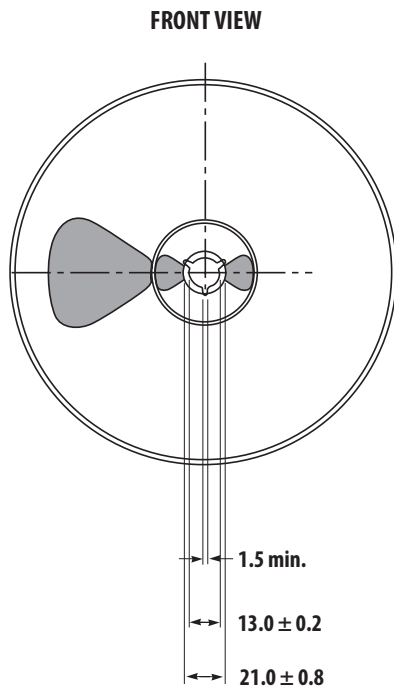

Figure 33. Orientation in Tape



NOTES:

1. Reel shall be labeled with the following information (as a minimum).
 - a. manufacturers name or symbol
 - b. Avago Technologies part number
 - c. purchase order number
 - d. date code
 - e. quantity of units
2. A certificate of compliance (c of c) shall be issued and accompany each shipment of product.
3. Reel must not be made with or contain ozone depleting materials.
4. All dimensions in millimeters (mm)

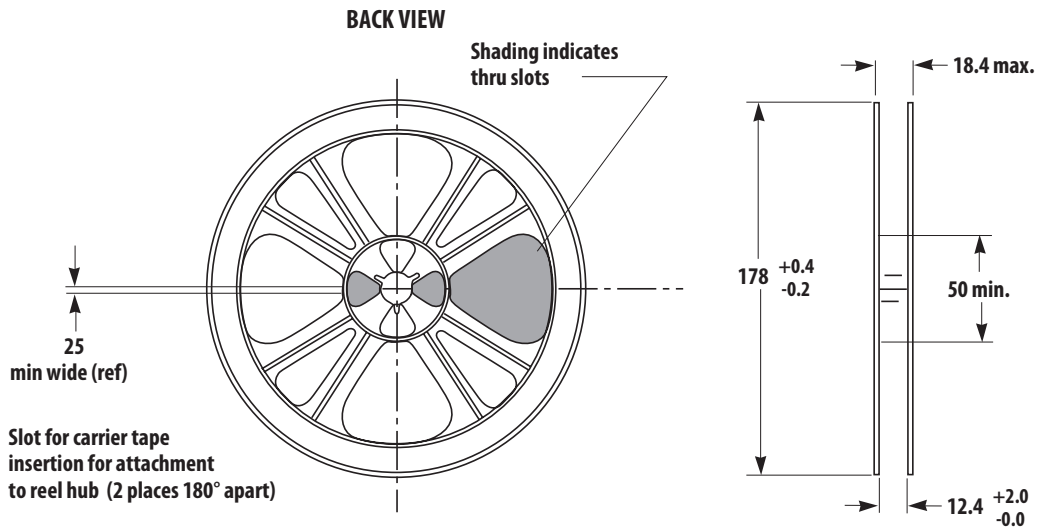

Figure 34. SMT Reel Drawing

Package Moisture Sensitivity

Feature	Test Method	Performance
Moisture Sensitivity Level (MSL) at 260°C	JESD22-A113D	Level 3

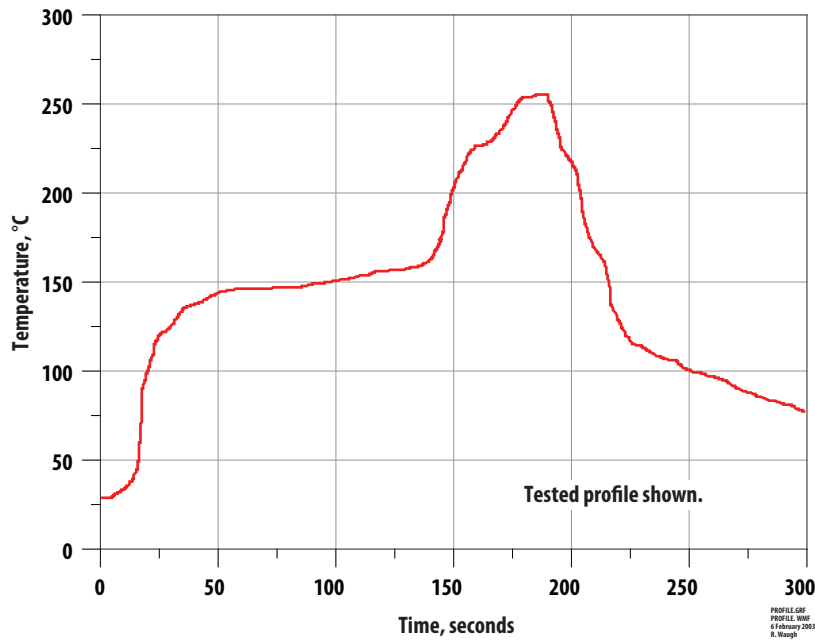

Figure 35. Verified SMT Solder Profile

Ordering Information

Part Number	No. of Devices	Container
ACMD-6207-BLK	100	Tape Strip or Anti-static Bag
ACMD-6207-TR1	3000	178 mm (7-inch) Reel

Appendix A – Package Marking Cross Reference

Marking "W"	Work Week	Marking "W" (cont)	Work Week (cont)
1	1	S	27
2	2	T	28
3	3	U	29
4	4	V	30
5	5	W	31
6	6	X	32
7	7	Y	33
8	8	Z	34
9	9	a	35
A	10	b	36
B	11	c	37
C	12	d	38
D	13	e	39
E	14	f	40
F	15	g	41
G	16	m	42
H	17	n	43
J	18	q	44
K	19	r	45
L	20	t	46
M	21	<	47
N	22	>	48
O	23	/	49
P	24	\	50
Q	25	(51
R	26)	52

For product information and a complete list of distributors, please go to our web site: www.avagotech.com

Avago, Avago Technologies, and the A logo are trademarks of Avago Technologies in the United States and other countries.
Data subject to change. Copyright © 2005-2013 Avago Technologies. All rights reserved.
AV02-4282EN - September 2, 2013



Looking for pricing, stock, or lifecycle information?

Click below to explore more details on WIN SOURCE:

 [View ACMD-6207-TR1 on WIN SOURCE](#)

 [Broadcom Limited](#) Information

Optimize Your Supply Chain with WIN SOURCE Solutions

-  Global Sourcing Solution
-  Obsolete Management
-  Cost Control Management
-  Shortage Management
-  Alternative Solution
-  Excess Inventory Management