

# PNZ108CL (PN108CL)

## Silicon planar type

For optical control systems

### ■ Features

- High sensitivity:  $I_L = 3.5 \text{ mA (min.)}$
- Narrow directivity characteristics for effective use of light input
- Fast response:  $t_r = 5 \text{ } \mu\text{s (typ.)}$
- Signal mixing capability using base pin
- Small size (low in height) package

### ■ Absolute Maximum Ratings $T_a = 25^\circ\text{C}$

Parameter	Symbol	Rating	Unit
Collector-emitter voltage (Base open)	$V_{CEO}$	20	V
Collector-base voltage (Emitter open)	$V_{CBO}$	30	V
Emitter-collector voltage (Base open)	$V_{ECO}$	3	V
Emitter-base voltage (Collector open)	$V_{EBO}$	5	V
Collector current	$I_C$	20	mA
Collector power dissipation	$P_C$	100	mW
Operating ambient temperature	$T_{opr}$	-25 to +85	$^\circ\text{C}$
Storage temperature	$T_{stg}$	-30 to +100	$^\circ\text{C}$

### ■ Electrical-Optical Characteristics $T_a = 25^\circ\text{C} \pm 3^\circ\text{C}$

Parameter	Symbol	Conditions	Min	Typ	Max	Unit
Photocurrent *1	$I_L$	$V_{CE} = 10 \text{ V, } L = 500 \text{ lx}$	3.5			mA
Collector-emitter cutoff current (Base open)	$I_{CEO}$	$V_{CE} = 10 \text{ V}$		0.05	2.0	$\mu\text{A}$
Collector-emitter saturation voltage *1	$V_{CE(sat)}$	$I_L = 1 \text{ mA, } L = 1000 \text{ lx}$		0.3	0.6	V
Peak sensitivity wavelength	$\lambda_{PD}$	$V_{CE} = 10 \text{ V}$		900		nm
Half-power angle	$\theta$	The angle when the photocurrent is halved		80		$^\circ$
Rise time *2	$t_r$	$V_{CC} = 10 \text{ V, } I_L = 5 \text{ mA, } R_L = 100 \text{ } \Omega$		5		$\mu\text{s}$
Fall time *2	$t_f$			6		$\mu\text{s}$

Note) 1. Measuring methods are based on JAPANESE INDUSTRIAL STANDARD JIS C 7030 measuring methods for transistors.

2. Spectral sensitivity characteristics: Sensitivity for wave length over 400 nm maximum sensitivity ratio is 100%.
3. This device is designed by disregarding radiation.
4. \*1:Source: Tungsten lamp (color temperature 2 856K)

\*2: Switching time measurement circuit

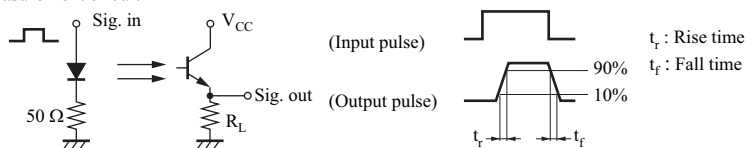

Note) The part number in the parenthesis shows conventional part number.

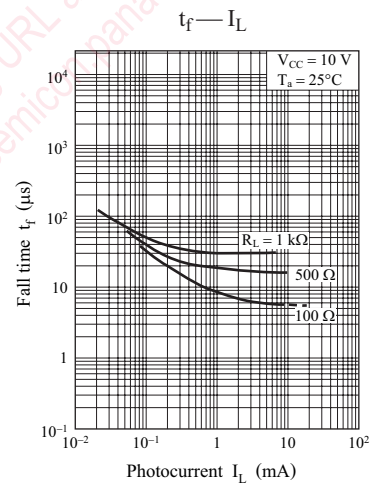
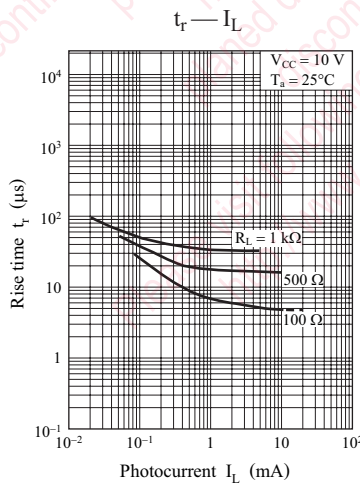
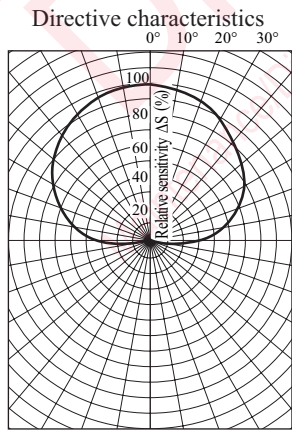
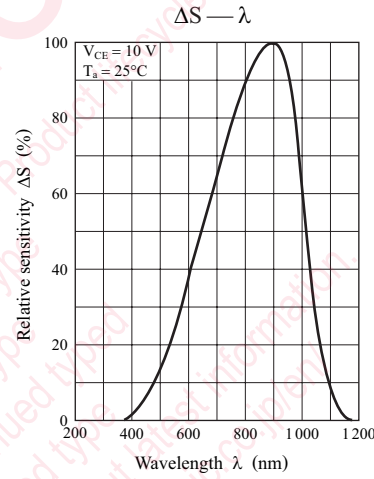
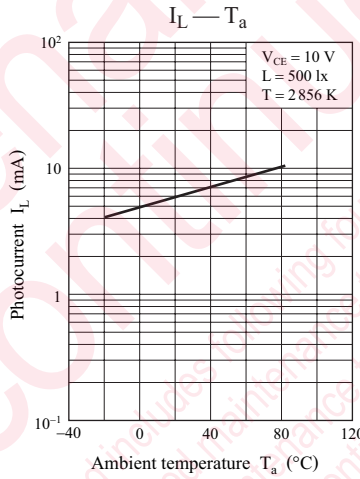
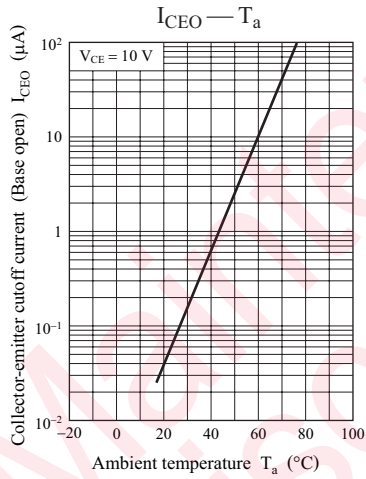
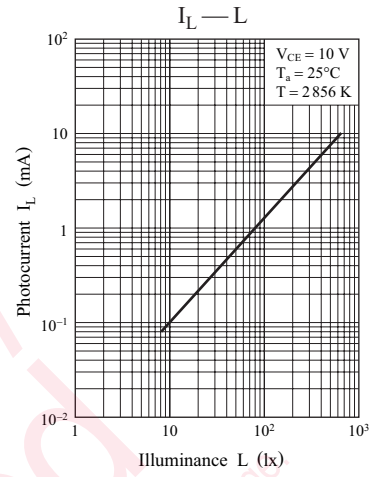
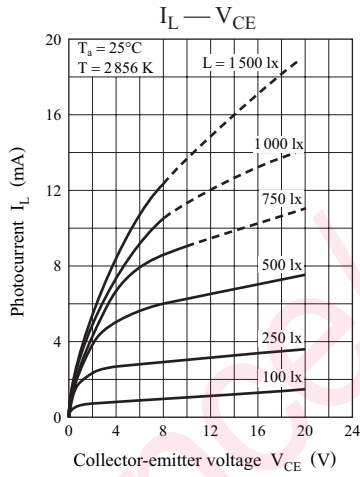
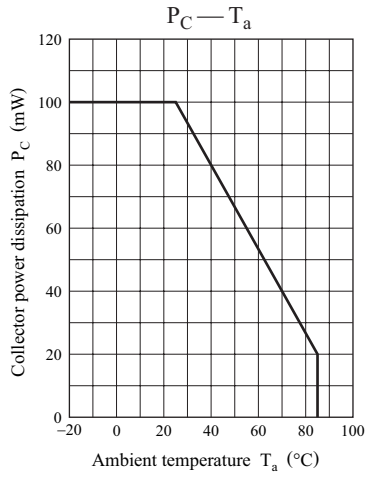

■ Package (Unit: mm)

MPDLTN3S0001

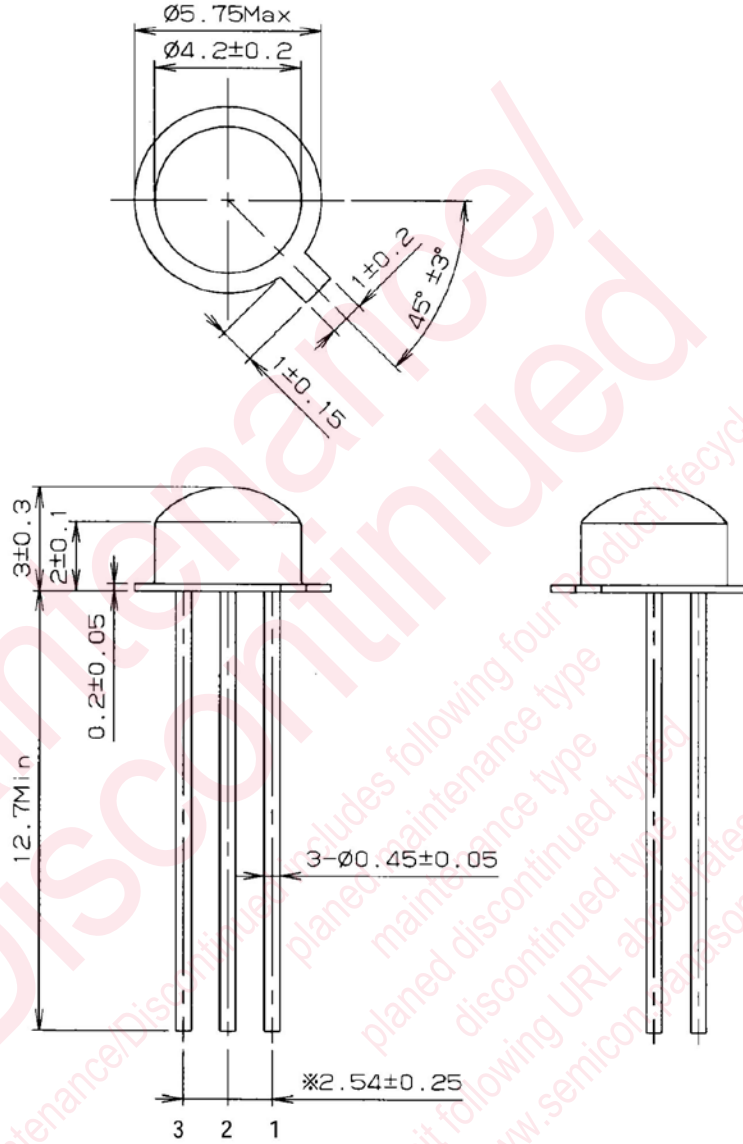

- Pin name
- 1: Emitter
- 2: Base
- 3: Collector

## Restrictions in using the technical information and applications described in this book

This book is to be exported or provided to non-residents, the laws and regulations related to security export control, must be observed.

This book is to show the main characteristics and application circuit examples of the products. It does not constitute a warranty of any property right or other right owned by Panasonic Corporation or any other company as to the infringement upon any such right owned by any other company. The information described in this book.

This book is for standard applications or general electronic equipment (such as office equipment and household appliances).

Special applications:

Automobiles, traffic control equipment, combustion equipment, life support equipment, etc. where high reliability are required, or if the failure or malfunction of the product

are subject to change without notice for modification and/or improvement of the products, therefore, ask for the most up-to-date Product Information to satisfy your requirements.

Do not exceed the absolute maximum rating and the guaranteed operating conditions (such as temperature range). Especially, please be careful not to exceed the range of absolute maximum rating for turn-on and mode-switching. Otherwise, we will not be liable for any damage or injury.



Please take into the consideration of incidence of break down and failure in the systems such as redundant design, arresting the spread of fire, fire, social damages, for example, by using the products.

Performance and characteristics change due to external factors (ESD, EOS, electrostatic discharge) or at customer's process. When using products for which the shelf life and the elapsed time since first opening the packages.

Do not use the products partially, without the prior written permission of our company.

## Looking for pricing, stock, or lifecycle information?

Click below to explore more details on WIN SOURCE:

-  [View PNZ108CL on WIN SOURCE](#)
-  [Panasonic Information](#)

## Optimize Your Supply Chain with WIN SOURCE Solutions

-  Global Sourcing Solution
-  Obsolete Management
-  Cost Control Management
-  Shortage Management
-  Alternative Solution
-  Excess Inventory Management