



**THE DATASHEET OF
PTRF1222IRTMR**





3.5-GHz Integrated Up-Converter

FEATURES

- Performs Up-Conversion in 3.5-GHz Radios (3300-3800 MHz)
- Integrated IF amplifier, Mixer and LO Buffer Amplifier
- Provision for external Image Reject / Band-Pass Filter
- TTL Switched Attenuator For Gain Control
- TTL Controlled Amplifier Power Down

KEY SPECIFICATIONS

- RF Frequency Range: 3300-3800 MHz
- 18 dB of Gain with 16-dB Digital Attenuator
- Output P-1dB: +14 dBm, Typical
- Output IP3: +24 dBm, Typical
- LO Drive Level = 0 dBm, Typical

DESCRIPTION

The TRF1222 up-converts a UHF IF signal to an RF signal in the 3300 to 3800 MHz range for 3.5-GHz radio applications. The TRF1222 has 18 dB of gain and an output P-1dB of 14 dBm, typical. A TTL compatible, 1-bit 16-dB digital attenuator is provided for gain control and the IF and RF amplifiers can be shut off via a TTL control signal for power critical or TDD applications. In order to provide system requirements for LO/spurious rejection, the TRF1222 offers a signal path to an off-chip band-pass filter. Specifications are provided assuming an in-band 2-dB insertion loss filter.

The TRF1222 is designed to complete the second up-conversion in Texas Instruments complete 3.5-GHz chip set. The linear nature of the up-converter makes it ideal for complex modulations schemes such as high order QAM or OFDM.

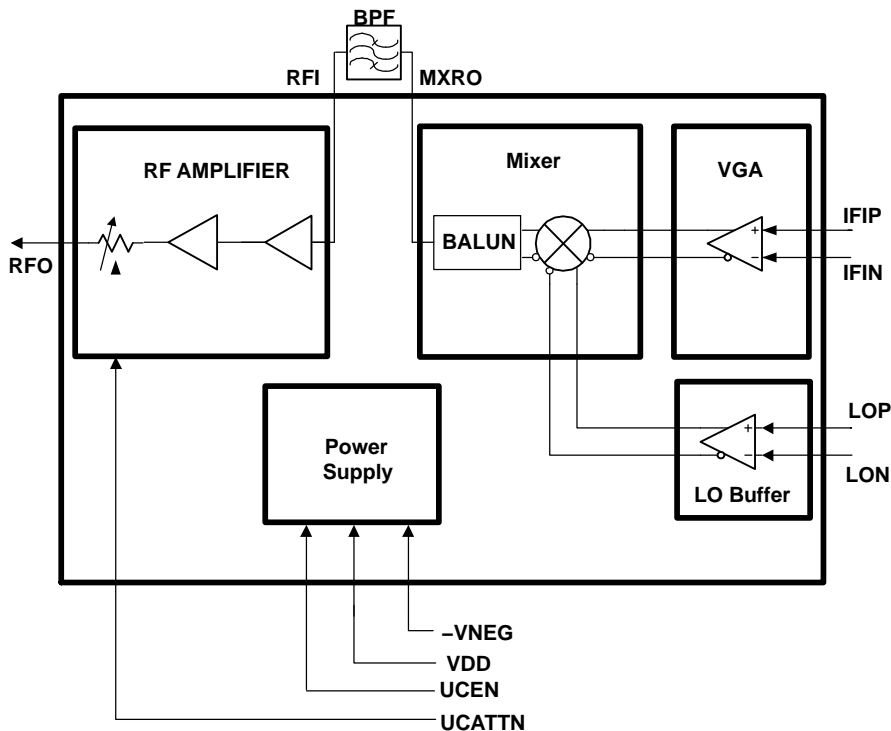

Figure 1. Block Diagram



Please be aware that an important notice concerning availability, standard warranty, and use in critical applications of Texas Instruments semiconductor products and disclaimers thereto appears at the end of this data sheet.

DEVICE INFORMATION

**LPCC-32 PACKAGE
(TOP VIEW)**

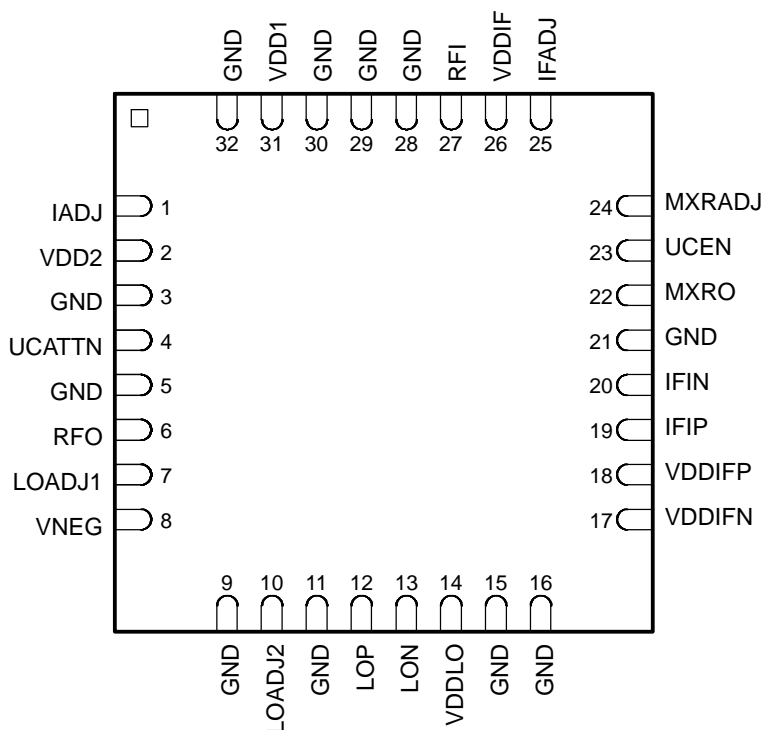

TERMINAL FUNCTIONS

TERMINAL NO.	NAME	I/O	TYPE	DESCRIPTION
1	IADJ			Not connected for normal operation. Amplifier bias adjustment. Do not ground this pin or connect to any other pin.
2	VDD2	I	Power	RF amplifier bias 5 V
3, 5, 9, 11, 15, 16, 21, 28, 29, 30, 32	GND			Ground
4	UCATTN	I	Digital	Logic high is high gain; logic low reduces gain by 16 dB. Normally set high.
6	RFO	O	Analog	RF output from RF amplifier
7	LOADJ1			Not connected for normal operation. LO common gate bias adjustment. Do not ground this pin or connect to any other pin.
8	VNEG	I	Power	Negative bias used for enable circuitry -5 V. This pin can be grounded if the user does not use the UCEN pin to turnoff the amplifier. If the VNEG is grounded the UCEN pin should be tied high.
10	LOADJ2			Not connected for normal operation. LO amplifier bias adjustment. Do not ground this pin or connect to any other pin.
12	LOP	I	Analog	LO input, positive, internally ac-coupled
13	LON	I	Analog	LO input, negative, internally ac-coupled
14	VDDLO	I	Power	Positive power for LO amplifier, 5 V
17	VDDIFN	I	Analog	VDD supply for IF amplifier, negative, 5 V
18	VDDIFP	I	Analog	VDD supply for IF amplifier, positive, 5 V
19	IFIP	I	Analog	IF input, positive, dc-coupled, typical dc voltage is 1.2 V

TERMINAL FUNCTIONS (continued)

TERMINAL		I/O	TYPE	DESCRIPTION
NO.	NAME			
20	IFI N	I	Analog	IF input, negative, dc-coupled typical dc voltage is 1.2 V
22	MXRO	O	Analog	Output of mixer (after balun) 50-Ω impedance with high impedance dc ground.
23	UCEN	I	Digital	Set high to enable IF amplifier and RF amplifiers
24	MXRADJ	O	Analog	Normally grounded. Provide 0-Ω jumper to ground.
25	IFADJ			Not connected for normal operation. IF amplifier bias adjustment. Do not ground this pin or connect to any other pin.
26	VDDIF	I	Power	Positive supply for IF bias circuitry 5 V
27	RFI	I	Analog	Input to RF amplifier, 50-Ω impedance, internally ac-coupled
31	VDD1	I	Power	RF amplifier bias 5 V
Back	GND			Back of package has metal base that must be grounded for thermal and RF performance.

ABSOLUTE MAXIMUM RATINGS

over operating free-air temperature range (unless otherwise noted)

		VALUE	UNIT
VDD	Positive dc supply voltage	0 to 5.5	V
-VDD	Negative dc supply voltage	-5.5 to 0	V
P _{IN}	RF input power	10	dBm
T _J	Junction temperature	200	°C
P _D	Power dissipation	1	W
	Digital input pins	-0.3 to 5.5	V
θ _{jc}	Thermal resistance junction-to-case ⁽¹⁾	9.01	°C/W
T _{stg}	Storage temperature	-40 to 105	°C
T _{op}	Operating temperature	-40 to 85	°C
	Lead temperature (40 Sec Max)	260	°C

(1) Thermal resistance is junction to ambient assuming thermal pad with 16 thermal vias under package metal base. See the recommended PCB layout.

ELECTRICAL CHARACTERISTICS

PARAMETER		TEST CONDITIONS	MIN	TYP	MAX	UNIT
DC CHARACTERISTICS						
V _{DD}	Positive supply voltage		4.75	5	5.25	V
I _{DD}	Positive supply current (total)			175	200	mA
V _{NEG}	Negative supply voltage		-5.25	-5	-4.75	V
I _{NEG}	Negative supply current			3	6	mA
I _{VDD2}	Supply current RF 2, pin 2			50		mA
I _{LO}	Supply current, LO, pin 14			50		mA
I _{IF}	Supply current, IF	Pin 17, 18, and 26 combined		47		mA
I _{VDD1}	Supply current RF1, pin 31			28		mA
V _{IH}	Input high voltage		2.5	5		V
V _{IL}	Input low voltage				0.8	V
I _{IH}	Input high current				300	μA
I _{IL}	Input low current				-50	μA

ELECTRICAL CHARACTERISTICS

Unless otherwise stated $V_{DD} = 5\text{ V}$, $f_{RF} = 3500\text{ MHz}$, $I_{DD} = 160\text{ mA}$, $V_{NEG} = -5\text{ V}$, $f_{RF} = 3.5\text{ GHz}$, $T_A = 25^\circ\text{C}$

PARAMETER		TEST CONDITIONS	MIN	TYP	MAX	UNIT
F_{IF}	IF input frequency			325		MHz
f_{RF}	RF output frequency		3300		3800	MHz
G	Gain	UCATTN = TTL high, input IF impedance is 100- Ω differential		22		dB
Δ_{ATTN}	Switched attenuator range	UCATTN from high-to-low		16		dB
G_{NB}	Gain flatness / 6 MHz				0.2	dB
OP-1dB	Output power at 1-dB compression, high gain	UCATTN = TTL high		14		dBm
OIP3	Output 3rd order intercept point, high gain	UCATTN = TTL high		24		dBm
	Gain - IF to MXRO	UCATTN = TTL high		1		dB
	Gain - RFI to RFO	UCATTN = TTL high		21		dB
P_{LO}	LO input power	Referenced to 100- Ω differential	-3	0	3	dB
	LO to RFO leakage ⁽¹⁾	LO input = 0 dBm		-5		dBm

(1) Performance is sensitive to impedance termination and board layout.

APPLICATION INFORMATION

A typical application schematic is shown in [Figure 3](#).

The PCB material recommendations are shown in [Table 1](#) and [Figure 2](#).

Table 1. PCB Recommendations

Board Material	FR4
Board Material Core Thickness	10 mil
Copper Thickness (starting)	1 oz
Prepreg Thickness	8 mil
Recommended Number of Layers	4
Via Plating Thickness	½ oz
Final Plate	White immersion tin
Final Board Thickness	33–37 mil

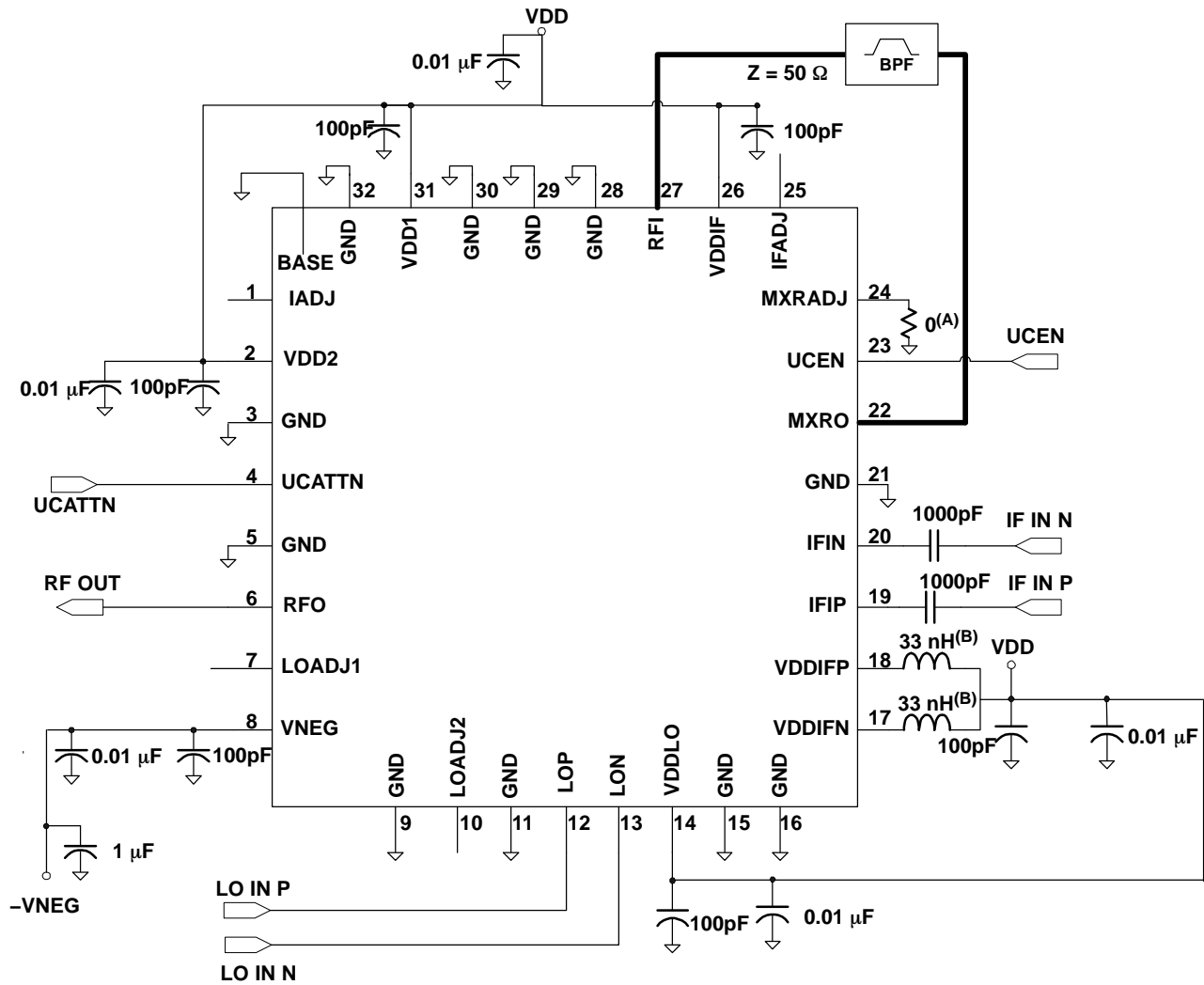

Place 100pF capacitors as close as possible to package pins.

- A. Connect pin 24 to ground through a 0-Ω resistor.
- B. Place 33-nH inductors close to package pins.
- C. Place 100-pF capacitors close as possible to package pins.

Figure 3. Recommended Application Schematic

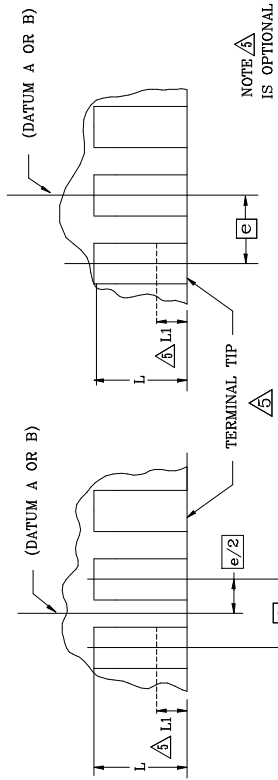

DETAIL B

PACKAGE REF.	MIN.	NOM.	MAX.
A	0.80	0.90	1.00
b	0.225	0.250	0.275
D	4.90	5.00	5.10
D2	3.650	3.800	3.950
E	4.90	5.00	5.10
E2	3.650	3.800	3.950
e	0.50 BSC.		
L	0.35	0.40	0.45
N	32		
ND	B		
NE	B		

Δ DIMENSION b APPLIES TO METALLIZED TERMINAL AND IS MEASURED BETWEEN 0.25mm AND 0.50mm FROM TERMINAL TIP. DIMENSION Li IS THE TERMINAL PULL BACK FROM PACKAGE EDGE. UP TO 0.1mm IS ACCEPTABLE. Li IS OPTIONAL.

ND AND NE REFER TO THE NUMBER OF TERMINAL ON EACH D AND E SIDE RESPECTIVELY.

SYMBOL	COMMON DIMENSIONS		TOLERANCES OF FORM AND POSITION
	MIN.	MAX.	
A1	0	0.02	0.05
A3	0.25 REF.		
k	0.20		
aaa	0.15		
bbb	0.10		
ccc	0.10		

- NOTES:
- DIMENSIONING AND TOLERANCING CONFORM TO ASME Y14.5M-1994.
 - ALL DIMENSIONS ARE IN MILLIMETERS. ANGLES ARE IN DEGREES.
 - N IS THE TOTAL NUMBER OF TERMINALS.
- Δ THE TERMINAL #1 IDENTIFIER AND TERMINAL NUMBERING CONVENTION SHALL CONFORM TO JEDEC 95-1 SPP-012. DETAILS OF TERMINAL #1 IDENTIFIER ARE OPTIONAL, BUT MUST BE LOCATED WITHIN THE ZONE INDICATED. THE TERMINAL #1 IDENTIFIER MAY BE EITHER A MOLD OR MARKED FEATURE.

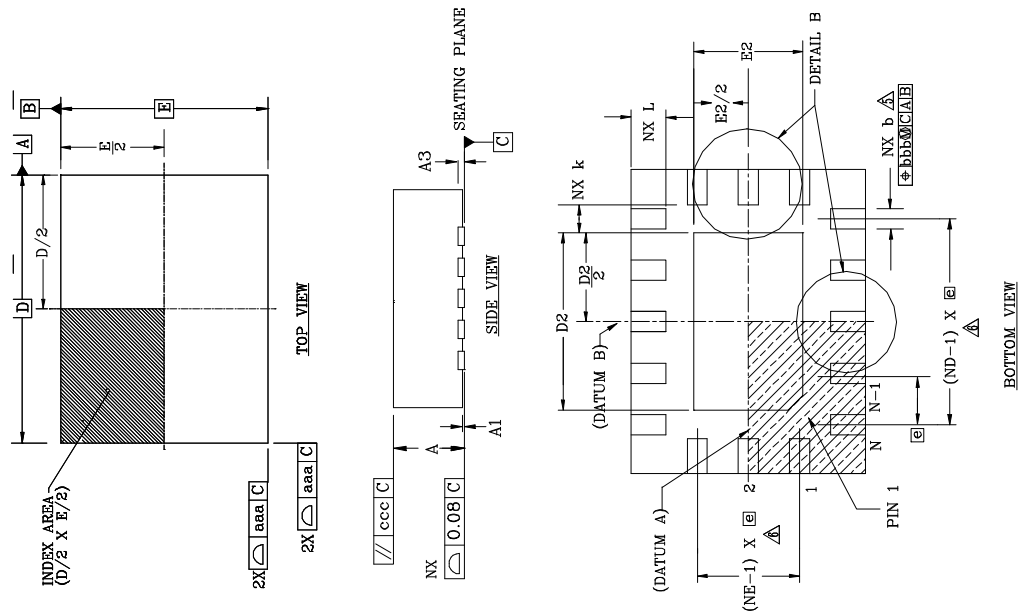
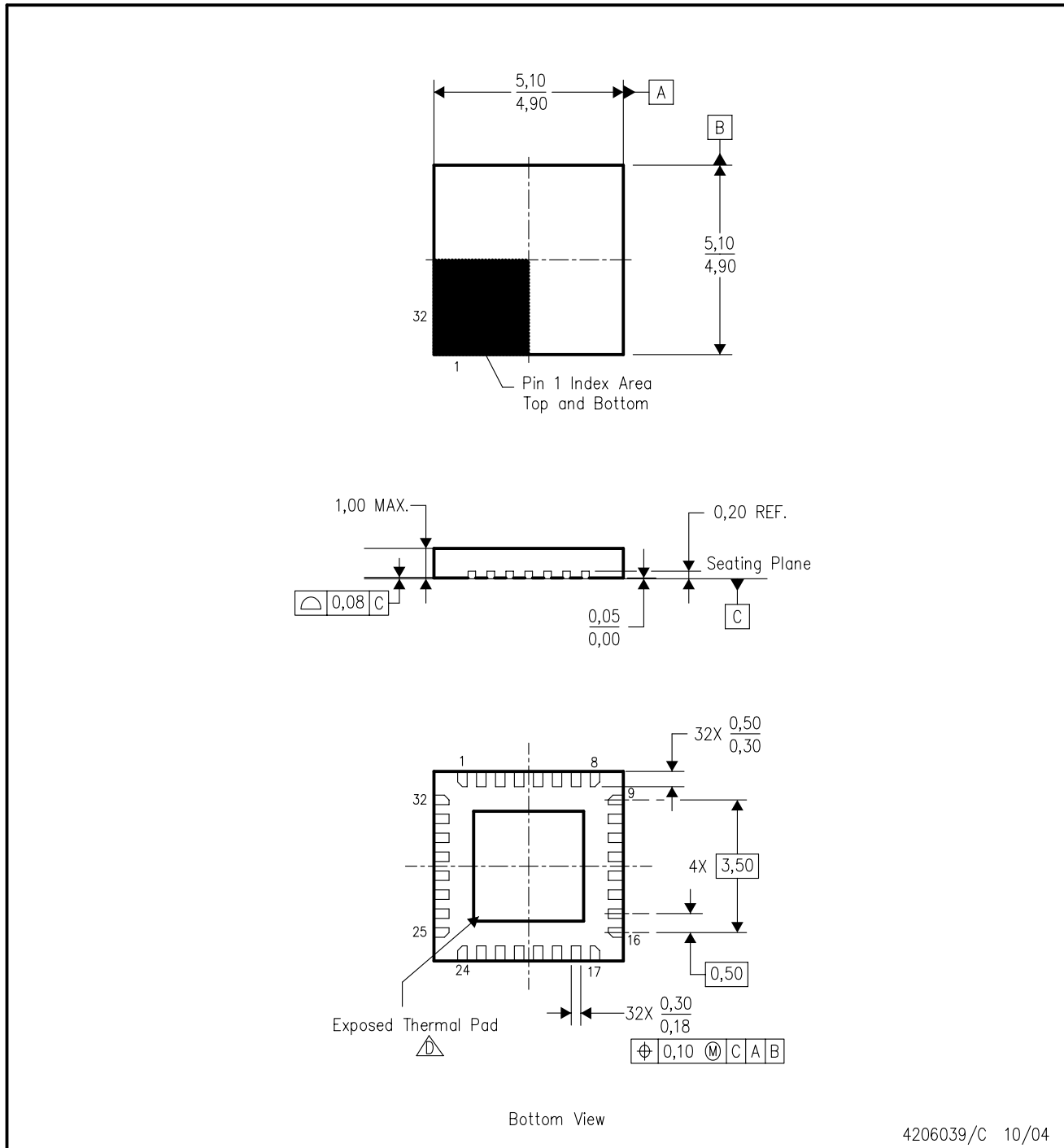

Figure 4. Package Outline 5 mm x 5 mm LPCC 32-Pin Leadless Package

RTM (S-PQFP-N32)

PLASTIC QUAD FLATPACK



- NOTES:
- A. All linear dimensions are in millimeters.
 - B. This drawing is subject to change without notice.
 - C. QFN (Quad Flatpack No-Lead) Package configuration.
 - The Package thermal pad must be soldered to the board for thermal and mechanical performance. See product data sheet for details regarding the exposed thermal pad dimensions.
 - E. Package complies to JEDEC MO-220.

PACKAGING INFORMATION

Orderable Device	Status (1)	Package Type	Package Drawing	Pins	Package Qty	Eco Plan (2)	Lead/Ball Finish (6)	MSL Peak Temp (3)	Op Temp (°C)	Device Marking (4/5)	Samples
TRF1222IRTMTG3	OBSOLETE	VQFN	RTM	32		TBD	Call TI	Call TI	-40 to 85	TRF 1222	

(1) The marketing status values are defined as follows:

ACTIVE: Product device recommended for new designs.

LIFEBUY: TI has announced that the device will be discontinued, and a lifetime-buy period is in effect.

NRND: Not recommended for new designs. Device is in production to support existing customers, but TI does not recommend using this part in a new design.

PREVIEW: Device has been announced but is not in production. Samples may or may not be available.

OBSOLETE: TI has discontinued the production of the device.

(2) Eco Plan - The planned eco-friendly classification: Pb-Free (RoHS), Pb-Free (RoHS Exempt), or Green (RoHS & no Sb/Br) - please check <http://www.ti.com/productcontent> for the latest availability information and additional product content details.

TBD: The Pb-Free/Green conversion plan has not been defined.

Pb-Free (RoHS): TI's terms "Lead-Free" or "Pb-Free" mean semiconductor products that are compatible with the current RoHS requirements for all 6 substances, including the requirement that lead not exceed 0.1% by weight in homogeneous materials. Where designed to be soldered at high temperatures, TI Pb-Free products are suitable for use in specified lead-free processes.

Pb-Free (RoHS Exempt): This component has a RoHS exemption for either 1) lead-based flip-chip solder bumps used between the die and package, or 2) lead-based die adhesive used between the die and leadframe. The component is otherwise considered Pb-Free (RoHS compatible) as defined above.

Green (RoHS & no Sb/Br): TI defines "Green" to mean Pb-Free (RoHS compatible), and free of Bromine (Br) and Antimony (Sb) based flame retardants (Br or Sb do not exceed 0.1% by weight in homogeneous material)

(3) MSL, Peak Temp. - The Moisture Sensitivity Level rating according to the JEDEC industry standard classifications, and peak solder temperature.

(4) There may be additional marking, which relates to the logo, the lot trace code information, or the environmental category on the device.

(5) Multiple Device Markings will be inside parentheses. Only one Device Marking contained in parentheses and separated by a "~" will appear on a device. If a line is indented then it is a continuation of the previous line and the two combined represent the entire Device Marking for that device.

(6) Lead/Ball Finish - Orderable Devices may have multiple material finish options. Finish options are separated by a vertical ruled line. Lead/Ball Finish values may wrap to two lines if the finish value exceeds the maximum column width.

Important Information and Disclaimer: The information provided on this page represents TI's knowledge and belief as of the date that it is provided. TI bases its knowledge and belief on information provided by third parties, and makes no representation or warranty as to the accuracy of such information. Efforts are underway to better integrate information from third parties. TI has taken and continues to take reasonable steps to provide representative and accurate information but may not have conducted destructive testing or chemical analysis on incoming materials and chemicals. TI and TI suppliers consider certain information to be proprietary, and thus CAS numbers and other limited information may not be available for release.

In no event shall TI's liability arising out of such information exceed the total purchase price of the TI part(s) at issue in this document sold by TI to Customer on an annual basis.

IMPORTANT NOTICE

Texas Instruments Incorporated and its subsidiaries (TI) reserve the right to make corrections, enhancements, improvements and other changes to its semiconductor products and services per JESD46, latest issue, and to discontinue any product or service per JESD48, latest issue. Buyers should obtain the latest relevant information before placing orders and should verify that such information is current and complete. All semiconductor products (also referred to herein as "components") are sold subject to TI's terms and conditions of sale supplied at the time of order acknowledgment.

TI warrants performance of its components to the specifications applicable at the time of sale, in accordance with the warranty in TI's terms and conditions of sale of semiconductor products. Testing and other quality control techniques are used to the extent TI deems necessary to support this warranty. Except where mandated by applicable law, testing of all parameters of each component is not necessarily performed.

TI assumes no liability for applications assistance or the design of Buyers' products. Buyers are responsible for their products and applications using TI components. To minimize the risks associated with Buyers' products and applications, Buyers should provide adequate design and operating safeguards.

TI does not warrant or represent that any license, either express or implied, is granted under any patent right, copyright, mask work right, or other intellectual property right relating to any combination, machine, or process in which TI components or services are used. Information published by TI regarding third-party products or services does not constitute a license to use such products or services or a warranty or endorsement thereof. Use of such information may require a license from a third party under the patents or other intellectual property of the third party, or a license from TI under the patents or other intellectual property of TI.

Reproduction of significant portions of TI information in TI data books or data sheets is permissible only if reproduction is without alteration and is accompanied by all associated warranties, conditions, limitations, and notices. TI is not responsible or liable for such altered documentation. Information of third parties may be subject to additional restrictions.

Resale of TI components or services with statements different from or beyond the parameters stated by TI for that component or service voids all express and any implied warranties for the associated TI component or service and is an unfair and deceptive business practice. TI is not responsible or liable for any such statements.

Buyer acknowledges and agrees that it is solely responsible for compliance with all legal, regulatory and safety-related requirements concerning its products, and any use of TI components in its applications, notwithstanding any applications-related information or support that may be provided by TI. Buyer represents and agrees that it has all the necessary expertise to create and implement safeguards which anticipate dangerous consequences of failures, monitor failures and their consequences, lessen the likelihood of failures that might cause harm and take appropriate remedial actions. Buyer will fully indemnify TI and its representatives against any damages arising out of the use of any TI components in safety-critical applications.

In some cases, TI components may be promoted specifically to facilitate safety-related applications. With such components, TI's goal is to help enable customers to design and create their own end-product solutions that meet applicable functional safety standards and requirements. Nonetheless, such components are subject to these terms.

No TI components are authorized for use in FDA Class III (or similar life-critical medical equipment) unless authorized officers of the parties have executed a special agreement specifically governing such use.

Only those TI components which TI has specifically designated as military grade or "enhanced plastic" are designed and intended for use in military/aerospace applications or environments. Buyer acknowledges and agrees that any military or aerospace use of TI components which have **not** been so designated is solely at the Buyer's risk, and that Buyer is solely responsible for compliance with all legal and regulatory requirements in connection with such use.

TI has specifically designated certain components as meeting ISO/TS16949 requirements, mainly for automotive use. In any case of use of non-designated products, TI will not be responsible for any failure to meet ISO/TS16949.

Products

Audio	www.ti.com/audio
Amplifiers	amplifier.ti.com
Data Converters	dataconverter.ti.com
DLP® Products	www.dlp.com
DSP	dsp.ti.com
Clocks and Timers	www.ti.com/clocks
Interface	interface.ti.com
Logic	logic.ti.com
Power Mgmt	power.ti.com
Microcontrollers	microcontroller.ti.com
RFID	www.ti-rfid.com
OMAP Applications Processors	www.ti.com/omap
Wireless Connectivity	www.ti.com/wirelessconnectivity

Applications

Automotive and Transportation	www.ti.com/automotive
Communications and Telecom	www.ti.com/communications
Computers and Peripherals	www.ti.com/computers
Consumer Electronics	www.ti.com/consumer-apps
Energy and Lighting	www.ti.com/energy
Industrial	www.ti.com/industrial
Medical	www.ti.com/medical
Security	www.ti.com/security
Space, Avionics and Defense	www.ti.com/space-avionics-defense
Video and Imaging	www.ti.com/video

TI E2E Community

e2e.ti.com

Looking for pricing, stock, or lifecycle information?

Click below to explore more details on WIN SOURCE:

 [View PTRF1222IRTMR](#) on WIN SOURCE

 [Texas Instruments](#) Information

Optimize Your Supply Chain with WIN SOURCE Solutions

-  Global Sourcing Solution
-  Obsolete Management
-  Cost Control Management
-  Shortage Management
-  Alternative Solution
-  Excess Inventory Management