



**THE DATASHEET OF  
844008BYI-15LFT**



## GENERAL DESCRIPTION

The 844008I-15 is an 8 output LVDS Synthesizer optimized to generate PCI Express<sup>™</sup> reference clock frequencies and is a member of the high performance clock solutions from IDT. Using a 25MHz parallel resonant crystal, the following frequencies can be generated based on F\_SEL pin: 100MHz or 125MHz. The 844008I-15 uses IDT's 3<sup>rd</sup> generation low phase noise VCO technology and can achieve <1ps typical rms phase jitter, easily meeting PCI Express jitter requirements. The 844008I-15 is packaged in a 32-pin LQFP package.

## FEATURES

- Eight LVDS outputs
- Crystal oscillator interface
- Supports the following output frequencies: 100MHz or 125MHz
- VCO: 500MHz
- RMS phase jitter @ 125MHz, using a 25MHz crystal (1.875MHz - 20MHz): 0.42ps (typical)
- Full 3.3V supply modes
- -40°C to 85°C ambient operating temperature
- Available in lead-free (RoHS 6) package

FREQUENCY SELECT FUNCTION TABLE

Input					Output Frequency (MHz)
Input Frequency (MHz)	F_SEL	M Divider Value	N Divider Value	M/N Divider Value	
25MHz	0	20	4	5	125
25MHz	1	20	5	4	100 (default)

## BLOCK DIAGRAM

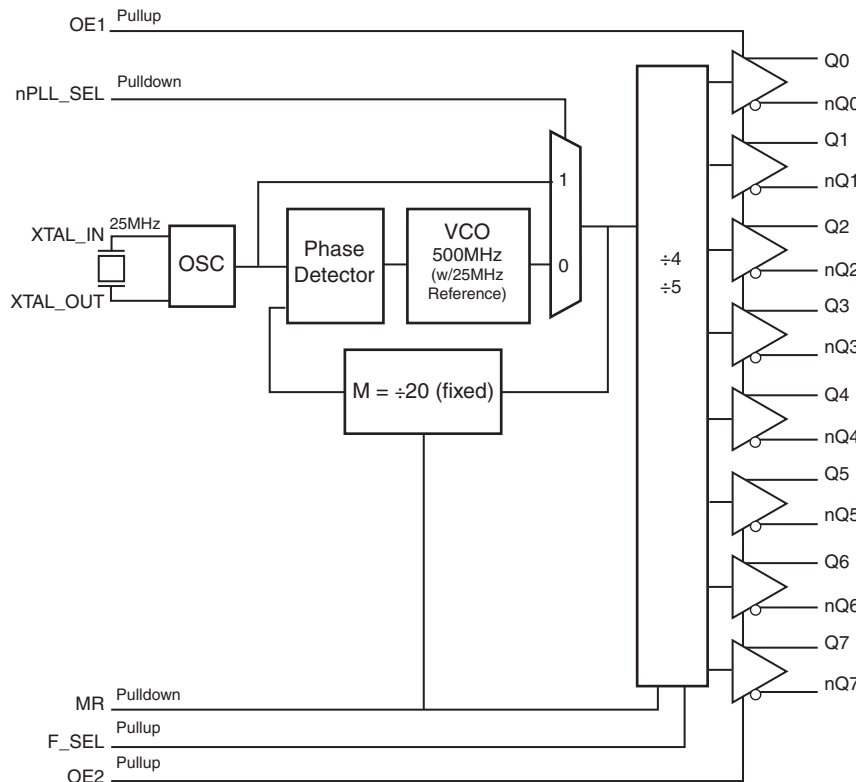

## PIN ASSIGNMENT

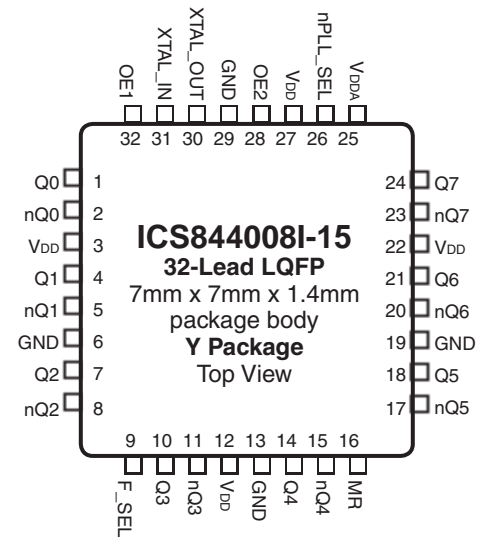

TABLE 1. PIN DESCRIPTIONS

Number	Name	Type		Description
1, 2	Q0, nQ0	Output		Differential output pair. LVDS interface levels.
3, 12, 22, 27	V <sub>DD</sub>	Power		Core supply pin.
4, 5	Q1, nQ1	Output		Differential output pair. LVDS interface levels.
6, 13, 19, 29	GND	Power		Power supply ground.
7, 8	Q2, nQ2	Output		Differential output pair. LVDS interface levels.
9	F_SEL	Input	Pullup	Frequency select pin LVCMOS/LVTTL interface levels.
10, 11	Q3, nQ3	Output		Differential output pair. LVDS interface levels.
14, 15	Q4, nQ4	Output		Differential output pair. LVDS interface levels.
16	MR	Input	Pulldown	Active HIGH Master Reset. When logic HIGH, the internal dividers are reset causing the true outputs Qx to go low and the inverted outputs nQx to go high. When logic LOW, the internal dividers and the outputs are enabled. LVCMOS/LVTTL interface levels.
17, 18	nQ5, Q5	Output		Differential output pair. LVDS interface levels.
20, 21	nQ6, Q6	Output		Differential output pair. LVDS interface levels.
23, 24	nQ7, Q7	Output		Differential output pair. LVDS interface levels.
25	V <sub>DDA</sub>	Power		Analog supply pin.
26	nPLL_SEL	Input	Pulldown	Selects between the PLL and XTAL as input to the dividers. When LOW, selects PLL (PLL Enable). When HIGH, selects the XTAL (PLL Bypass). LVCMOS/LVTTL interface levels.
28	OE2	Input	Pullup	Output enable for Q5/nQ5:Q7/nQ7 outputs. LVCMOS/LVTTL interface levels.
30, 31	XTAL_OUT, XTAL_IN	Input		Parallel resonant crystal interface. XTAL_OUT is the output, XTAL_IN is the input.
32	OE1	Input	Pullup	Output enable for Q0/nQ0:Q4/nQ4 outputs. LVCMOS/LVTTL interface levels.

NOTE: Pullup and Pulldown refer to internal input resistors. See Table 2, Pin Characteristics, for typical values.

TABLE 2. PIN CHARACTERISTICS

Symbol	Parameter	Test Conditions	Minimum	Typical	Maximum	Units
C <sub>IN</sub>	Input Capacitance			4		pF
R <sub>PULLDOWN</sub>	Input Pulldown Resistor			51		kΩ
R <sub>PULLUP</sub>	Input Pullup Resistor			51		kΩ

TABLE 3A. OE1 FUNCTION TABLE

Input	Outputs
OE1	Q0:Q4, nQ0:nQ4
0	Places outputs in Hi-Z state
1	Normal operation

TABLE 3B. OE2 FUNCTION TABLE

Input	Outputs
OE2	Q5:Q7, nQ5:nQ7
0	Places outputs in Hi-Z state
1	Normal operation

**ABSOLUTE MAXIMUM RATINGS**

Supply Voltage, $V_{DD}$	4.6V
Inputs, $V_I$	-0.5V to $V_{DD} + 0.5V$
Outputs, $I_O$	
Continuous Current	10mA
Surge Current	15mA
Package Thermal Impedance, $\theta_{JA}$	65.7°C/W (0 mps)
Storage Temperature, $T_{STG}$	-65°C to 150°C

NOTE: Stresses beyond those listed under Absolute Maximum Ratings may cause permanent damage to the device. These ratings are stress specifications only. Functional operation of product at these conditions or any conditions beyond those listed in the *DC Characteristics* or *AC Characteristics* is not implied. Exposure to absolute maximum rating conditions for extended periods may affect product reliability.

**TABLE 4A. POWER SUPPLY DC CHARACTERISTICS,  $V_{DD} = V_{DDA} = 3.3V \pm 5\%$ ,  $T_A = -40^\circ C$  TO  $85^\circ C$** 

Symbol	Parameter	Test Conditions	Minimum	Typical	Maximum	Units
$V_{DD}$	Core Supply Voltage		3.135	3.3	3.465	V
$V_{DDA}$	Analog Supply Voltage		$V_{DD} - 0.15$	3.3	$V_{DD}$	V
$I_{DD}$	Power Supply Current				150	mA
$I_{DDA}$	Analog Supply Current				15	mA

**TABLE 4B. LVCMOS / LVTTTL DC CHARACTERISTICS,  $V_{DD} = V_{DDA} = 3.3V \pm 5\%$ ,  $T_A = -40^\circ C$  TO  $85^\circ C$** 

Symbol	Parameter	Test Conditions	Minimum	Typical	Maximum	Units
$V_{IH}$	Input High Voltage	$V_{DD} = 3.3V$	2		$V_{DD} + 0.3$	V
$V_{IL}$	Input Low Voltage	$V_{DD} = 3.3V$	-0.3		0.8	V
$I_{IH}$	Input High Current	MR, nPLL_SEL	$V_{DD} = V_{IN} = 3.465$		150	$\mu A$
		OE1, OE2, F_SEL	$V_{DD} = V_{IN} = 3.465$		5	$\mu A$
$I_{IL}$	Input Low Current	MR, nPLL_SEL	$V_{DD} = 3.465V, V_{IN} = 0V$	-5		$\mu A$
		OE1, OE2, F_SEL	$V_{DD} = 3.465V, V_{IN} = 0V$	-150		$\mu A$

**TABLE 4C. LVDS DC CHARACTERISTICS,  $V_{DD} = V_{DDA} = 3.3V \pm 5\%$ ,  $T_A = -40^\circ C$  TO  $85^\circ C$** 

Symbol	Parameter	Test Conditions	Minimum	Typical	Maximum	Units
$V_{OD}$	Differential Output Voltage		260	360	460	mV
$\Delta V_{OD}$	$V_{OD}$ Magnitude Change				50	mV
$V_{OS}$	Offset Voltage		1.2	1.3	1.5	V
$\Delta V_{OS}$	$V_{OS}$ Magnitude Change				50	mV
$I_{OZ}$	High Impedance Leakage Current		-10	$\pm 1$	10	$\mu A$
$I_{OFF}$	Power Off Leakage		-20	$\pm 1$	20	$\mu A$
$I_{OSD}$	Differential Output Short Circuit Current			-3.5	-5	mA
$I_{OS}$	Output Short Circuit Current			-3.5	-5	mA

TABLE 5. CRYSTAL CHARACTERISTICS

Parameter	Test Conditions	Minimum	Typical	Maximum	Units
Mode of Oscillation		Fundamental			
Frequency			25		MHz
Parts per Million (ppm); NOTE 1				100	ppm
Equivalent Series Resistance (ESR)				40	$\Omega$
Shunt Capacitance				5	pF
Drive Level				100	$\mu$ W

NOTE: Characterized using an 18pF parallel resonant crystal.

NOTE 1: When used with recommended 50ppm crystal and external trim caps adjusted for user PC board.

TABLE 6. AC CHARACTERISTICS,  $V_{DD} = V_{DDA} = 3.3V \pm 5\%$ ,  $T_A = -40^\circ\text{C}$  TO  $85^\circ\text{C}$ 

Symbol	Parameter	Test Conditions	Minimum	Typical	Maximum	Units
$f_{OUT}$	Output Frequency	FSEL = 0		125		MHz
		FSEL = 1		100		MHz
tsk(o)	Output Skew; NOTE 1, 2				110	ps
tsk(b)	Bank Skew; NOTE 2, 3	Q0/nQ0:Q4/nQ4			50	ps
		Q5/nQ5:Q7/nQ7			50	ps
tjit(cc)	Cycle-to-Cycle Jitter				25	ps
tjit( $\emptyset$ )	RMS Phase Jitter (Random); NOTE 4	125MHz, (1.875MHz - 20MHz)		0.42		ps
		100MHz, (1.875MHz - 20MHz)		0.46		ps
$t_R / t_F$	Output Rise/Fall Time	20% to 80%	100		600	ps
odc	Output Duty Cycle		45		55	%

Minimum and Maximum values are design target specs.

NOTE 1: Defined as skew between outputs at the same supply voltages and with equal load conditions.

Measured at  $V_{DD}/2$ .

NOTE 2: This parameter is defined in accordance with JEDEC Standard 65.

NOTE 3: Defined as skew within a bank of outputs at the same voltages and with equal load conditions.

NOTE 4: Please refer to the Phase Noise Plot.

### TYPICAL PHASE NOISE AT 125MHz

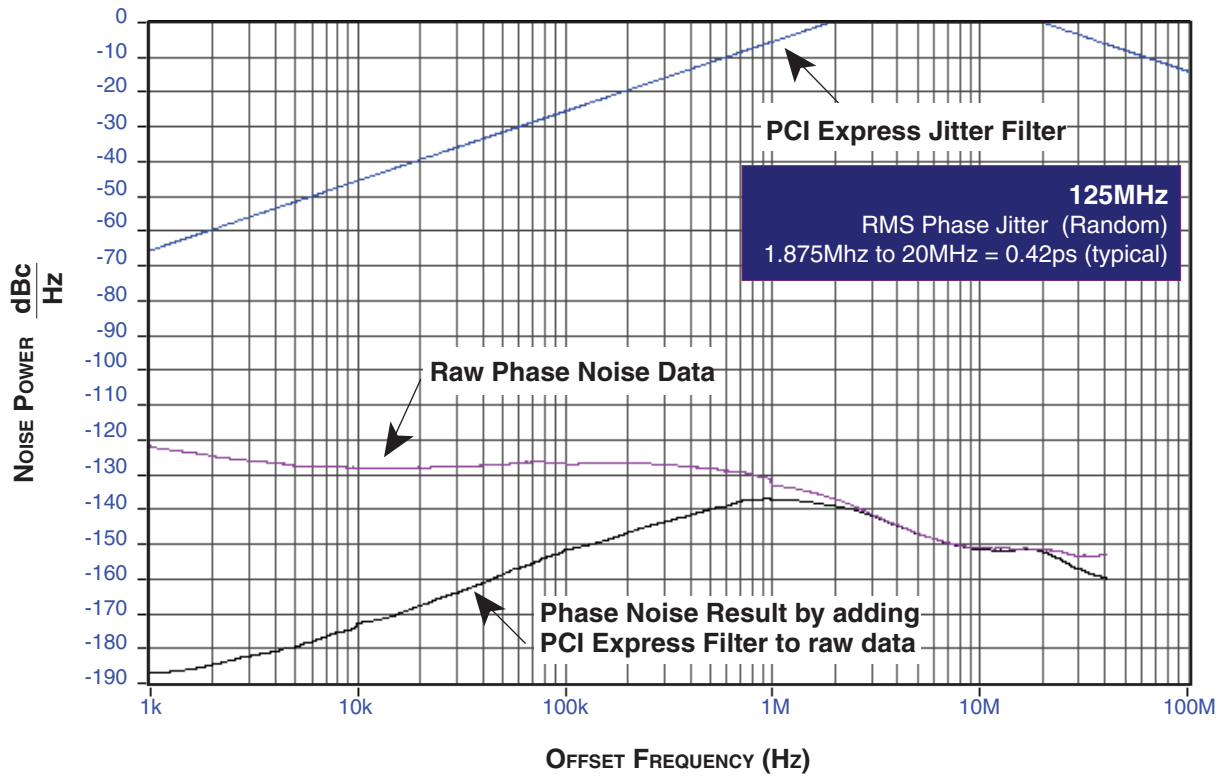

### TYPICAL PHASE NOISE AT 100MHz

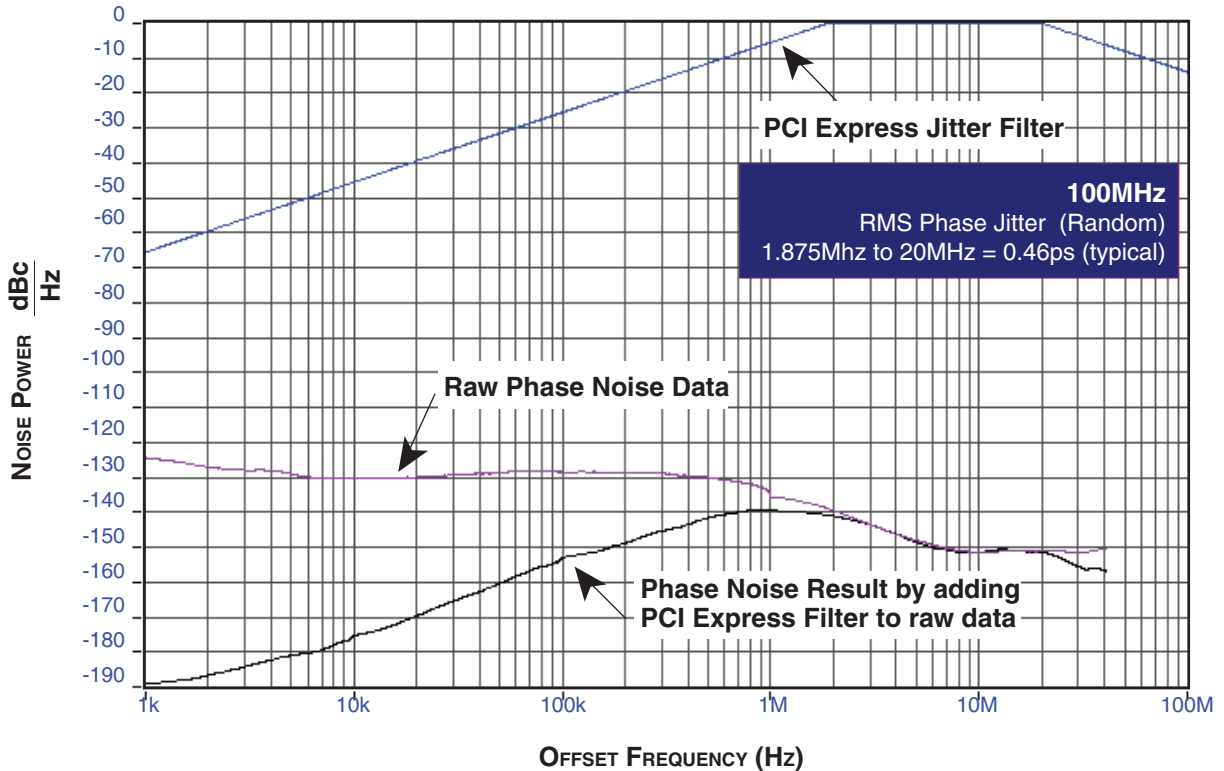

# PARAMETER MEASUREMENT INFORMATION

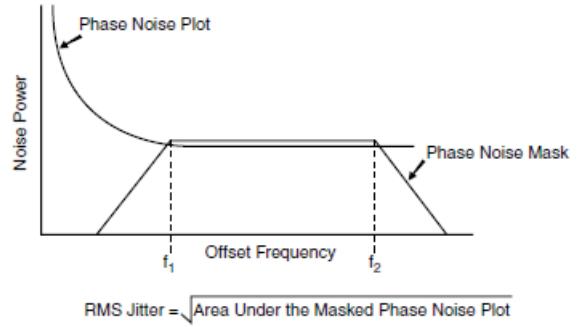
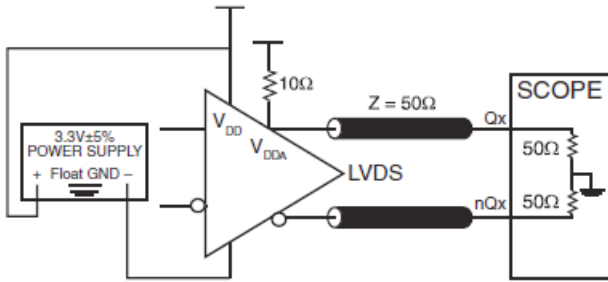

**3.3V CORE/3.3V OUTPUT LOAD AC TEST CIRCUIT**

**RMS PHASE JITTER**

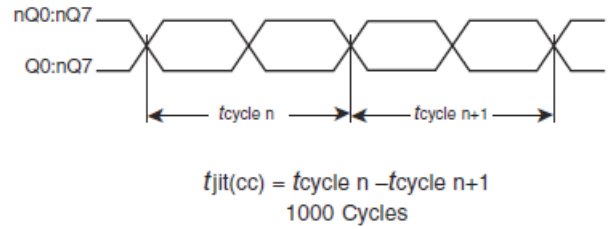
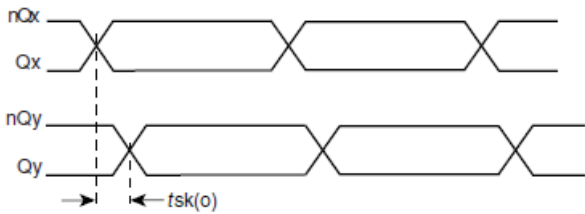

**OUTPUT SKEW**

**CYCLE-TO-CYCLE JITTER**

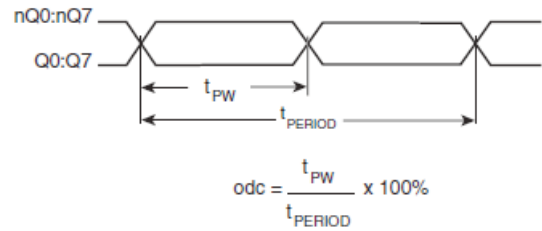
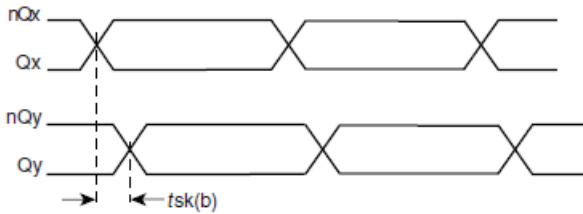

Where x = 0, 1, 2, 3 or 4, and  
Where y = 5, 6 or 7

**BANK SKEW**

**OUTPUT DUTY CYCLE/PULSE WIDTH/PERIOD**

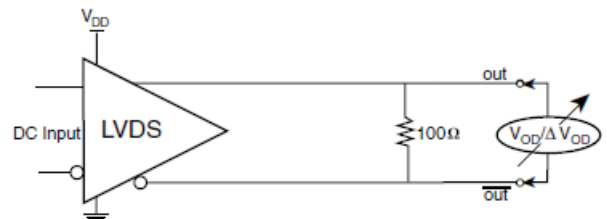
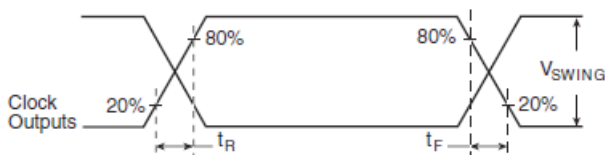

**OUTPUT RISE/FALL TIME**

**DIFFERENTIAL OUTPUT VOLTAGE SETUP**

# PARAMETER MEASUREMENT INFORMATION, CONTINUED

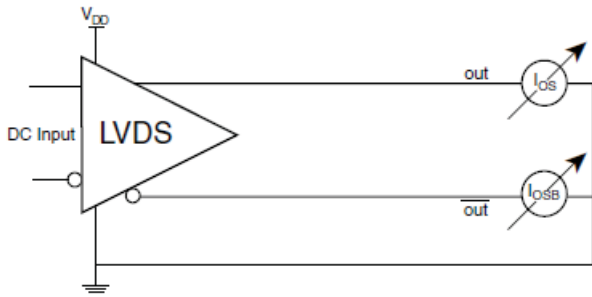

OFFSET VOLTAGE SETUP

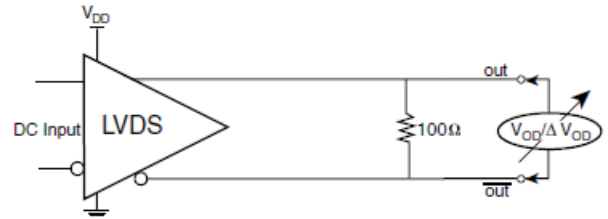

DIFFERENTIAL OUTPUT VOLTAGE SETUP

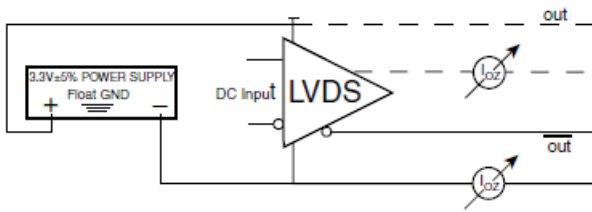

HIGH IMPEDANCE LEAKAGE CURRENT SETUP

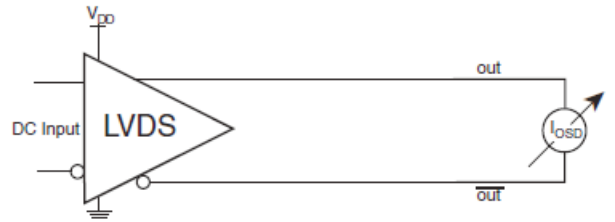

DIFFERENTIAL OUTPUT SHORT CIRCUIT SETUP

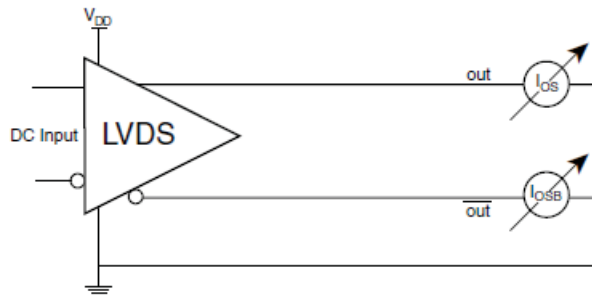

OUTPUT SHORT CIRCUIT CURRENT SETUP

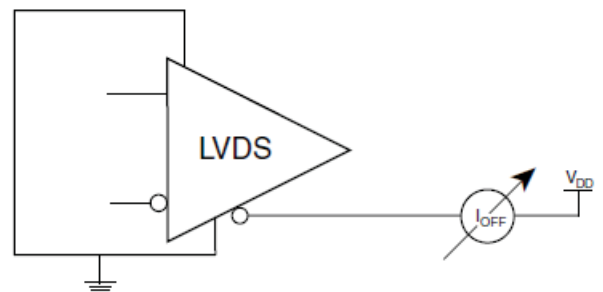

POWER OFF LEAKAGE SETUP

## APPLICATION INFORMATION

### POWER SUPPLY FILTERING TECHNIQUES

As in any high speed analog circuitry, the power supply pins are vulnerable to random noise. The 844008I-15 provides separate power supplies to isolate any high switching noise from the outputs to the internal PLL.  $V_{DD}$  and  $V_{DDA}$  should be individually connected to the power supply plane through vias, and bypass capacitors should be used for each pin. To achieve optimum jitter performance, power supply isolation is required. *Figure 1* illustrates how a 10Ω resistor along with a 10μF and a 0.01μF bypass capacitor should be connected to each  $V_{DDA}$ .

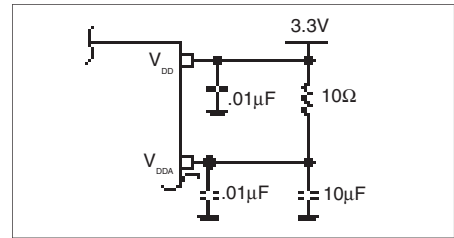

FIGURE 1. POWER SUPPLY FILTERING

### CRYSTAL INPUT INTERFACE

The 844008I-15 has been characterized with an 18pF parallel resonant crystals. The capacitor values shown in

*Figure 2* below were determined using a 25MHz parallel resonant crystal and were chosen to minimize the ppm error.

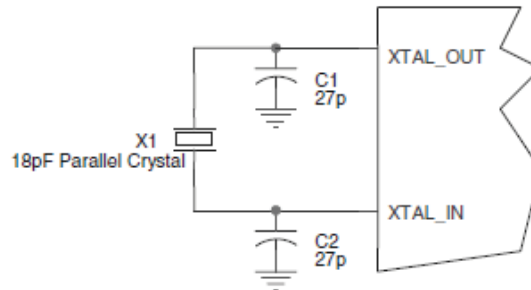

FIGURE 2. CRYSTAL INPUT INTERFACE

### RECOMMENDATIONS FOR UNUSED INPUT AND OUTPUT PINS

#### INPUTS:

##### LVC MOS CONTROL PINS:

All control pins have internal pull-ups or pull-downs; additional resistance is not required but can be added for additional protection. A 1kΩ resistor can be used.

#### OUTPUTS:

##### LVDS

All unused LVDS outputs should be terminated with 100Ω resistor between the differential pair.

### 3.3V LVDS DRIVER TERMINATION

A general LVDS interface is shown in *Figure 3*. In a 100Ω differential transmission line environment, LVDS drivers require a matched load termination of 100Ω across near the receiver input. For a

multiple LVDS outputs buffer, if only partial outputs are used, it is recommended to terminate the unused outputs.

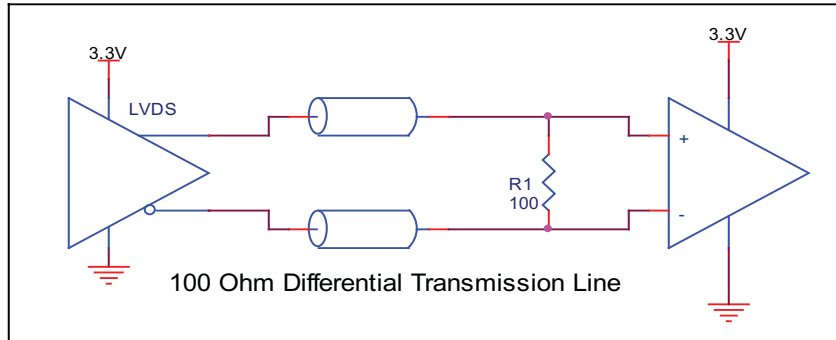

FIGURE 3. TYPICAL LVDS DRIVER TERMINATION

### SCHEMATIC EXAMPLE

*Figure 4* shows an example of 8440081-15 application schematic. In this example, the device is operated at  $V_{DD}=3.3V$ . The 18pF parallel resonant 25MHz crystal is used. The  $C1 = 27pF$  and  $C2 = 27pF$  are recommended for frequency accuracy. For

different board layout, the  $C1$  and  $C2$  may be slightly adjusted for optimizing frequency accuracy. Two examples of LVDS for receiver without built-in termination are shown in this schematic.

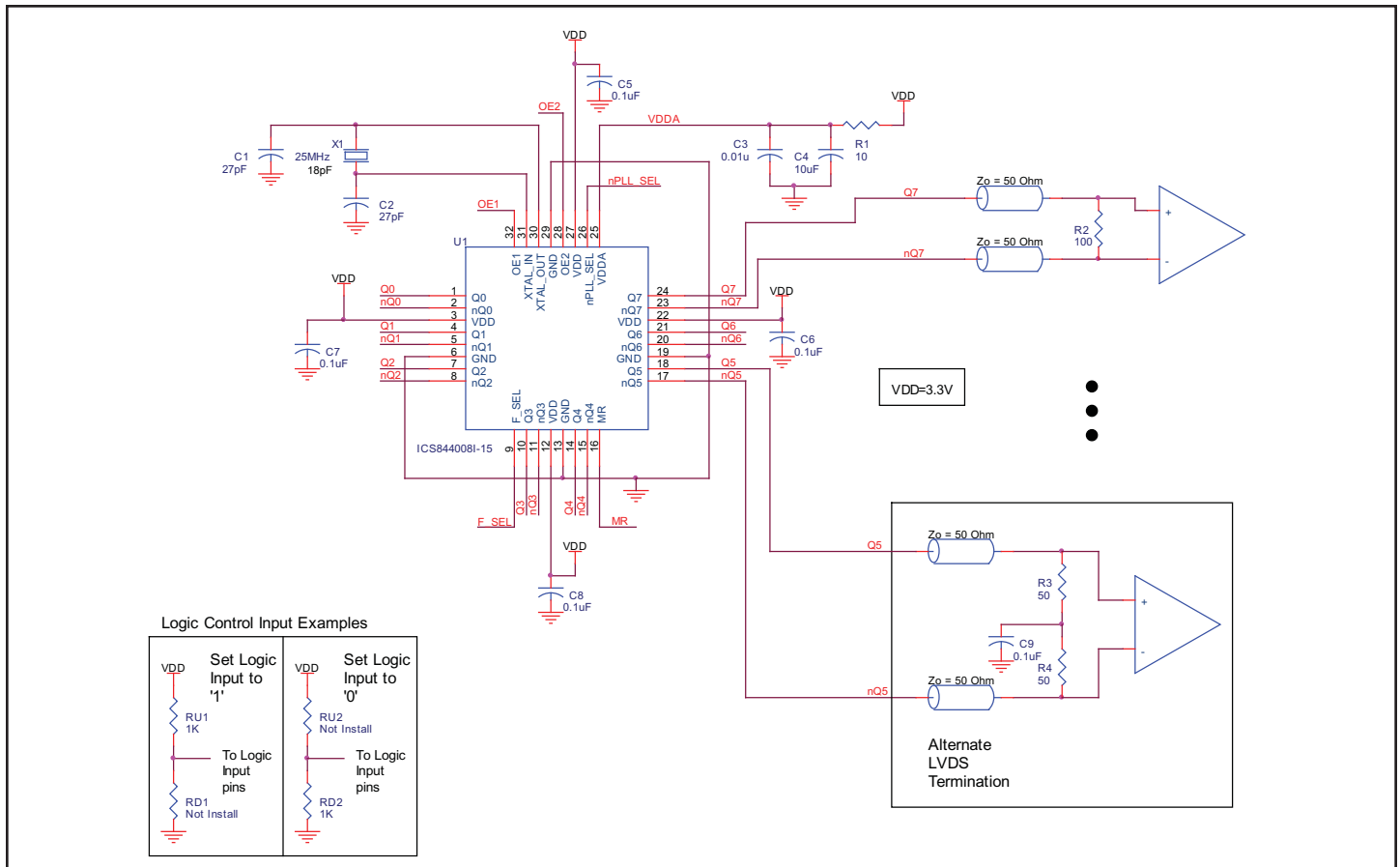

FIGURE 4. 8440081-15 SCHEMATIC EXAMPLE

## POWER CONSIDERATIONS

This section provides information on power dissipation and junction temperature for the 844008I-15. Equations and example calculations are also provided.

### 1. Power Dissipation.

The total power dissipation for the 844008I-15 is the sum of the core power plus the power dissipated in the load(s).

The following is the power dissipation for  $V_{DD} = 3.3V + 5\% = 3.465V$ , which gives worst case results.

- Power (core)<sub>MAX</sub> =  $V_{DD\_MAX} * (I_{DD\_MAX} + I_{DDA\_MAX}) = 3.465V * (150mA + 15mA) = 571.73mW$

### 2. Junction Temperature.

Junction temperature,  $T_j$ , is the temperature at the junction of the bond wire and bond pad and directly affects the reliability of the device. The maximum recommended junction temperature for HiPerClockS™ devices is 125°C.

The equation for  $T_j$  is as follows:  $T_j = \theta_{JA} * Pd\_total + T_A$

$T_j$  = Junction Temperature

$\theta_{JA}$  = Junction-to-Ambient Thermal Resistance

$Pd\_total$  = Total Device Power Dissipation (example calculation is in section 1 above)

$T_A$  = Ambient Temperature

In order to calculate junction temperature, the appropriate junction-to-ambient thermal resistance  $\theta_{JA}$  must be used. Assuming no air flow and a multi-layer board, the appropriate value is 65.7°C/W per Table 7 below.

Therefore,  $T_j$  for an ambient temperature of 85°C with all outputs switching is:

$$85^\circ\text{C} + 0.572\text{W} * 65.7^\circ\text{C}/\text{W} = 122.5^\circ\text{C}. \text{ This is below the limit of } 125^\circ\text{C}.$$

This calculation is only an example.  $T_j$  will obviously vary depending on the number of loaded outputs, supply voltage, air flow, and the type of board (single layer or multi-layer).

**TABLE 7. THERMAL RESISTANCE  $\theta_{JA}$  FOR 32-LEAD LQFP, FORCED CONVECTION**

	$\theta_{JA}$ by Velocity (Meters per Second)		
	0	1	2.5
Multi-Layer PCB, JEDEC Standard Test Boards	65.7°C/W	55.9°C/W	52.4°C/W

## RELIABILITY INFORMATION

**TABLE 8.  $\theta_{JA}$  vs. AIR FLOW TABLE FOR 32 LEAD LQFP**

$\theta_{JA}$ by Velocity (Meters per Second)			
	0	1	2.5
Multi-Layer PCB, JEDEC Standard Test Boards	65.7°C/W	55.9°C/W	52.4°C/W

### TRANSISTOR COUNT

The transistor count for 844008I-15 is: 2609

PACKAGE OUTLINE - Y SUFFIX FOR 32 LEAD LQFP

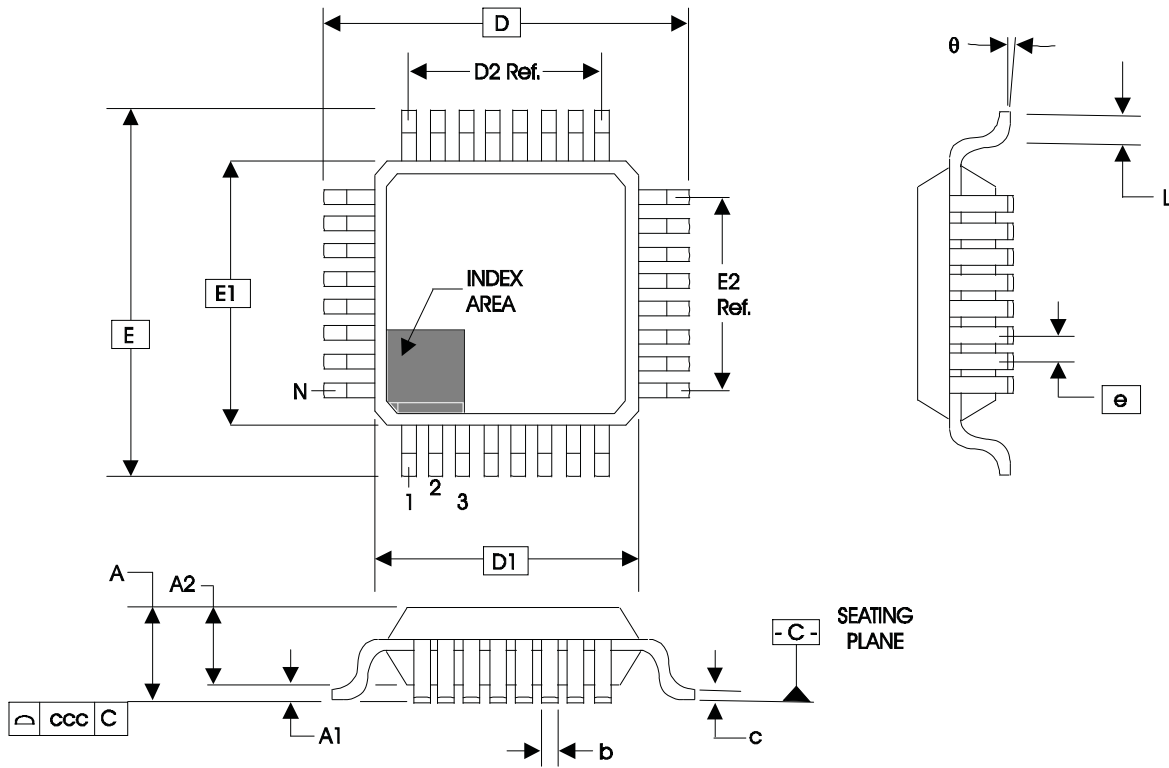

TABLE 9. PACKAGE DIMENSIONS

JEDEC VARIATION ALL DIMENSIONS IN MILLIMETERS			
SYMBOL	BBA		
	MINIMUM	NOMINAL	MAXIMUM
N	32		
A	--	--	1.60
A1	0.05	--	0.15
A2	1.35	1.40	1.45
b	0.30	0.37	0.45
c	0.09	--	0.20
D	9.00 BASIC		
D1	7.00 BASIC		
D2	5.60 Ref.		
E	9.00 BASIC		
E1	7.00 BASIC		
E2	5.60 Ref.		
e	0.80 BASIC		
L	0.45	0.60	0.75
θ	0°	--	7°
ccc	--	--	0.10

Reference Document: JEDEC Publication 95, MS-026

**TABLE 10. ORDERING INFORMATION**

Part/Order Number	Marking	Package	Shipping Packaging	Temperature
844008BYI-15LF	ICS4008BI15L	32 Lead "Lead-Free" LQFP	tube	-40°C to 85°C
844008BYI-15LFT	ICS4008BI15L	32 Lead "Lead-Free" LQFP	tape & reel	-40°C to 85°C

NOTE: Parts that are ordered with an "LF" suffix to the part number are the Pb-Free configuration and are RoHS compliant.

**REVISION HISTORY SHEET**

<b>Rev</b>	<b>Table</b>	<b>Page</b>	<b>Description of Change</b>	<b>Date</b>
A	T10	13	Ordering Information - Removed ICS from Part/Order number. Updated data sheet format.	7/2/15

**Corporate Headquarters**

6024 Silver Creek Valley Road  
San Jose, California 95138

**Sales**

800-345-7015 or +408-284-8200  
Fax: 408-284-2775  
www.IDT.com

**Technical Support**

**email:** [clocks@idt.com](mailto:clocks@idt.com)

DISCLAIMER Integrated Device Technology, Inc. (IDT) and its subsidiaries reserve the right to modify the products and/or specifications described herein at any time and at IDT's sole discretion. All information in this document, including descriptions of product features and performance, is subject to change without notice. Performance specifications and the operating parameters of the described products are determined in the independent state and are not guaranteed to perform the same way when installed in customer products. The information contained herein is provided without representation or warranty of any kind, whether express or implied, including, but not limited to, the suitability of IDT's products for any particular purpose, an implied warranty of merchantability, or non-infringement of the intellectual property rights of others. This document is presented only as a guide and does not convey any license under intellectual property rights of IDT or any third parties.

IDT's products are not intended for use in applications involving extreme environmental conditions or in life support systems or similar devices where the failure or malfunction of an IDT product can be reasonably expected to significantly affect the health or safety of users. Anyone using an IDT product in such a manner does so at their own risk, absent an express, written agreement by IDT.

Integrated Device Technology, IDT and the IDT logo are registered trademarks of IDT. Other trademarks and service marks used herein, including protected names, logos and designs, are the property of IDT or their respective third party owners.

Copyright 2015. All rights reserved.

## Looking for pricing, stock, or lifecycle information?

Click below to explore more details on WIN SOURCE:

- ⊖ [View 844008BYI-15LFT on WIN SOURCE](#)
- ⊖ [IDT, Integrated Device Technology Inc Information](#)

## Optimize Your Supply Chain with WIN SOURCE Solutions

- ✓ Global Sourcing Solution
- ✓ Obsolete Management
- ✓ Cost Control Management
- ✓ Shortage Management
- ✓ Alternative Solution
- ✓ Excess Inventory Management