



**THE DATASHEET OF  
ISL90460WIH527Z-TK**



## ISL90460

Single Volatile 32-Tap XDCP™ Digitally Controlled Potentiometer (XDCP)

FN8225  
Rev 4.00  
October 22, 2015

The Intersil ISL90460 is a digitally controlled potentiometer (XDCP). Configured as a variable resistor, the device consists of a resistor array, wiper switches, a control section, and volatile memory. The wiper position is controlled by a 2-pin Up/Down interface.

The potentiometer is implemented by a resistor array composed of 31 resistive elements and a wiper switching network. Between each element and at either end are tap points accessible to the wiper terminal. The position of the wiper element is controlled by the  $\overline{CS}$  and  $U/\overline{D}$  inputs.

The device can be used in a wide variety of applications including:

- LCD contrast control
- Parameter and bias adjustments
- Industrial and automotive control
- Transducer adjustment of pressure, temperature, position, chemical, and optical sensors
- Laser Diode driver biasing
- Gain control and offset adjustment

### Features

- Volatile Solid-State Potentiometer
- 2-pin UP/DN Interface
- DCP Terminal Voltage, 2.7V to 5.5V
- Tempco 35ppm/°C Typical
- 32 Wiper Tap Points
- Low Power CMOS
  - Active current 25μA max.
  - Supply current 0.3μA
- Available  $R_{TOTAL}$  Values = 10kΩ, 50kΩ, 100kΩ
- Temp Range -40°C to +85°C
- Packages
  - 5 Ld SC-70, SOT-23
- Pb-Free Plus Anneal Available (RoHS Compliant)

### Pinout

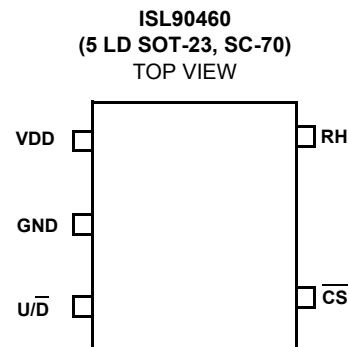

## Ordering Information

PART NUMBER	PART MARKING	R <sub>TOTAL</sub> (K)	TEMP RANGE (°C)	PACKAGE (Tape and Reel)	PKG. DWG. #
ISL90460WIE527Z-TK (See Note) <b>No longer available or supported, recommended replacement: ISL90460TIH527Z-TK</b>	DDY	10	-40 to +85	5 Ld SC-70 (Pb-free)	P5.049
ISL90460WIH527Z -TK (See Note)	DDZ		-40 to +85	5 Ld SOT-23 (Pb-free)	P5.064
ISL90460UIE527Z-TK (See Note) <b>No longer available or supported, recommended replacement: ISL90460TIH527Z-TK</b>	DDW	50	-40 to +85	5 Ld SC-70 (Pb-free)	P5.049
ISL90460UIH527Z -TK (See Note) <b>No longer available or supported, recommended replacement: ISL90460TIH527Z-TK</b>	DDX		-40 to +85	5 Ld SOT-23 (Pb-free)	P5.064
ISL90460TIE527Z-TK (See Note) <b>No longer available or supported, recommended replacement: ISL90460TIH527Z-TK</b>	DDU	100	-40 to +85	5 Ld SC-70 (Pb-free)	P5.049
ISL90460TIH527Z-TK (See Note)	DDV		-40 to +85	5 Ld SOT-23 (Pb-free)	P5.064

NOTE: Intersil Pb-free plus anneal products employ special Pb-free material sets; molding compounds/die attach materials and 100% matte tin plate termination finish, which are RoHS compliant and compatible with both SnPb and Pb-free soldering operations. Intersil Pb-free products are MSL classified at Pb-free peak reflow temperatures that meet or exceed the Pb-free requirements of IPC/JEDEC J STD-020.

## Block Diagram

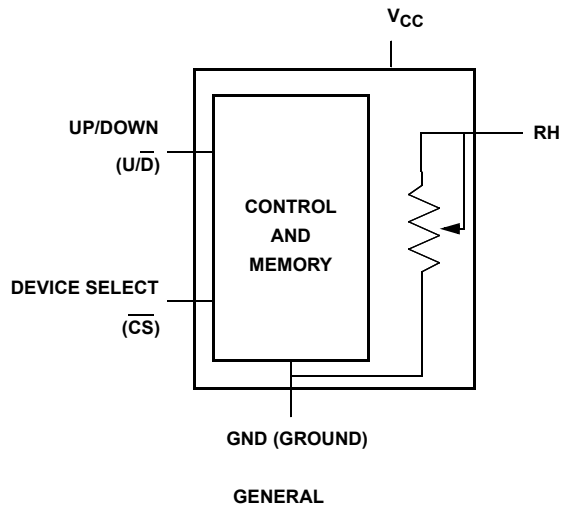

## Pin Descriptions

SOT-23/SC-70 5-PIN	SYMBOL	DESCRIPTION
1	VDD	Supply voltage
2	GND	Ground
3	U/D	Up - Down
4	CS	Chip select
5	RH	High terminal/Wiper terminal

**Absolute Maximum Ratings**

Storage Temperature . . . . . -65°C to +150°C  
 Voltage on CS, U/D and V<sub>CC</sub> with Respect to GND . . . . -1V to +7V  
 Lead Temperature (Soldering 10s) . . . . . 300°C  
 I<sub>W</sub> (10s) . . . . . ±6mA  
 Power Rating . . . . . 1mW

**Recommended Operating Conditions**

Temperature Range (Industrial) . . . . . -40°C to 85°C  
 Supply Voltage (V<sub>CC</sub>) . . . . . 2.7V to 5.5V

*CAUTION: Stresses above those listed under "Absolute Maximum Ratings" may cause permanent damage to the device. This is a stress rating only; functional operation of the device (at these or any other conditions above those listed in the operational sections of this specification) is not implied. Exposure to absolute maximum rating conditions for extended periods may affect device reliability.*

**Potentiometer Specifications** Over recommended operating conditions unless otherwise stated

SYMBOL	PARAMETER	CONDITIONS	MIN	TYP (Note 4)	MAX	UNIT
R <sub>TOT</sub>	End to end resistance	W version	8	10	12	kΩ
		U version	40	50	60	kΩ
		T version	80	100	120	kΩ
V <sub>R</sub>	R <sub>H</sub> , R <sub>L</sub> terminal voltages		0		V <sub>CC</sub>	V
	Noise	Ref: 1kHz		-120		dBV
R <sub>W</sub>	Wiper Resistance			600		Ω
I <sub>W</sub>	Wiper Current				0.6	mA
	Resolution		1		32	Taps
	Absolute linearity (Note 1)	R <sub>H(n)(actual)</sub> - R <sub>H(n)(expected)</sub>			±1	MI (Note 3)
	Relative linearity (Note 2)	R <sub>H(n+1)</sub> - [R <sub>H(n)</sub> +MI]			±0.5	MI (Note 3)
	R <sub>TOTAL</sub> temperature coefficient			±35		ppm/°C
C <sub>H</sub> /C <sub>L</sub> /C <sub>W</sub>	Potentiometer capacitances	See equivalent circuit		10/10/25		pF

## NOTES:

1. Absolute linearity is utilized to determine actual wiper voltage versus expected voltage = (R<sub>H(n)(actual)</sub> - R<sub>H(n)(expected)</sub>) = ±1 MI Maximum. n = 1 .. 29 only.
2. Relative linearity is a measure of the error in step size between taps = R<sub>H(n+1)</sub> - [R<sub>H(n)</sub> + MI] = ±0.5 MI, n = 1 .. 29 only.
3. 1 MI = Minimum Increment = R<sub>TOT</sub>/31.
4. Typical values are for T<sub>A</sub> = 25°C and nominal supply voltage.

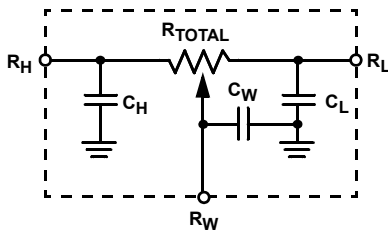
**Equivalent Circuit**

DC Electrical Specifications Over recommended operating conditions unless otherwise specified.

SYMBOL	PARAMETER	TEST CONDITIONS	MIN	TYP (Note 4)	MAX	UNIT
$I_{CC}$	$V_{CC}$ active current (Increment)	$\overline{CS} = 0V, U/\overline{D} = f_{clock} = 1MHz$ and $V_{CC} = 3V$			25	$\mu A$
$I_{SB}$	Standby supply current	$\overline{CS} = V_{CC}, U/\overline{D} = V_{SS}$ or $V_{CC} = 3V$		0.3	1	$\mu A$
$I_{LI}$	$\overline{CS}$ input leakage current	$V_{IN} = V_{SS}$ to $V_{CC}$			$\pm 1$	$\mu A$
$I_{LI}$	$U/\overline{D}$ input leakage current	$V_{IN} = V_{SS}$ to $V_{CC}$			$\pm 1$	$\mu A$
$V_{IH}$	$\overline{CS}, U/\overline{D}$ input HIGH voltage		$V_{CC} \times 0.7$			V
$V_{IL}$	$\overline{CS}, U/\overline{D}$ input LOW voltage				$V_{CC} \times 0.3$	V
$C_{IN}$	$\overline{CS}, U/\overline{D}$ input capacitance	$V_{CC} = 3V, V_{IN} = V_{SS}, T_A = 25^\circ C, f = 1MHz$		10		pF

Timing Specifications Over recommended operating conditions unless otherwise specified) (Figures 1 and 2)

SYMBOL	PARAMETER	MIN	TYP (Note 4)	MAX	UNIT
$t_{CU}$	$U/\overline{D}$ to $\overline{CS}$ setup	25			ns
$t_{CI}$	$\overline{CS}$ to $U/\overline{D}$ setup	50			ns
$t_{IC}$	$\overline{CS}$ to $U/\overline{D}$ hold	25			ns
$t_{L}$	$U/\overline{D}$ LOW period	300			ns
$t_{H}$	$U/\overline{D}$ HIGH period	300			ns
$f_{TOGGLE}$	Up/Down toggle rate		1		MHz
$t_{SETTLE}$	Output settling time		1		$\mu s$

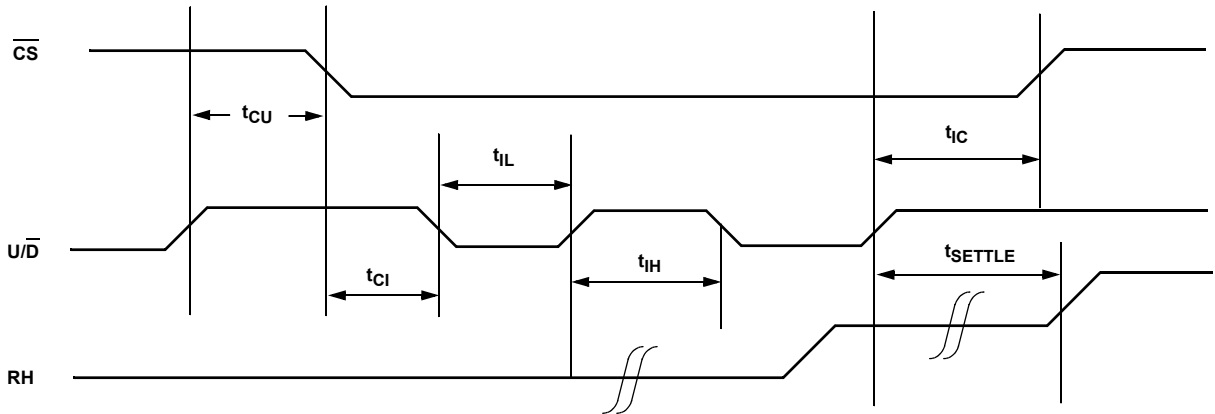

FIGURE 1. SERIAL INTERFACE TIMING DIAGRAM, INCREMENT

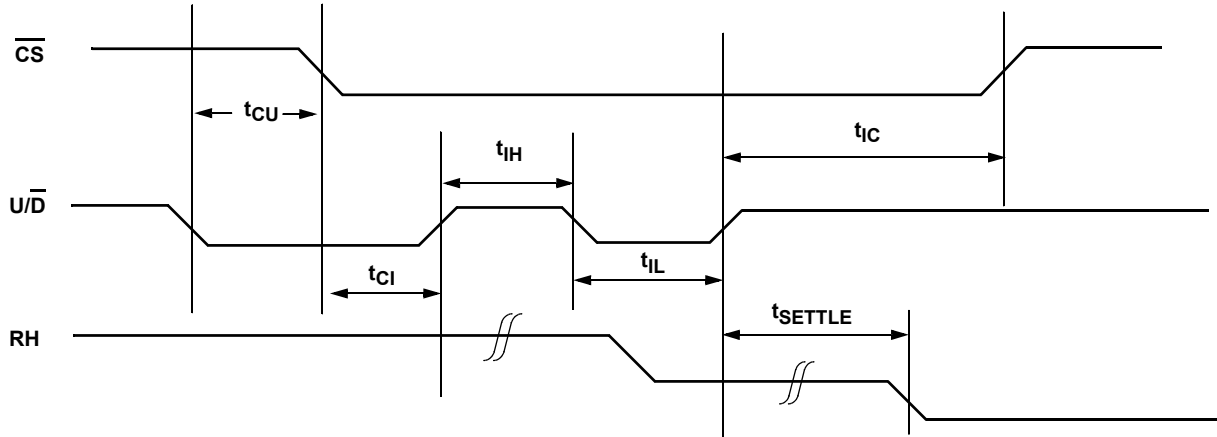

FIGURE 2. SERIAL INTERFACE TIMING DIAGRAM, DECREMENT

## Pin Descriptions

### RH

The ISL90460 contains a digital potentiometer connected as a rheostat or variable resistor. The wiper and one terminal of the digital potentiometer is tied to the RH pin, and the other terminal of the potentiometer is tied to the ground pin (GND). The resistance from the RH pin to ground will vary with the potentiometer setting; at the highest setting, the resistance will be the maximum ( $R_{tot}$ ), at the lowest setting it will be a minimum.

### Up/Down ( $\overline{U/D}$ )

The  $\overline{U/D}$  input controls the direction of the wiper movement and whether the counter is incremented or decremented.

### Chip Select ( $\overline{CS}$ )

The device is selected when the  $\overline{CS}$  input is LOW. The current counter value is stored in volatile memory when  $\overline{CS}$  is returned HIGH. When  $\overline{CS}$  is high, the device is placed in low power standby mode.

## Principles of Operation

There are two sections of the ISL90460: the input control, counter and decode section; and the resistor array. The input control section operates just like an up/down counter. The output of this counter is decoded to turn on a single electronic switch connecting a point on the resistor array to the wiper output. The resistor array is comprised of 31 individual resistors connected in series. At either end of the array and between each resistor is an electronic switch that transfers the connection at that point to the wiper. The wiper is connected to the RH terminal, forming a variable resistor from RH to GND.

The direction of the wiper movement is defined when the device is selected. If during  $\overline{CS}$  transition from High to Low the  $\overline{U/D}$  input is LOW, the wiper will move down on each rising edge of  $\overline{U/D}$  toggling. Similarly, the wiper will move up on each rising edge of  $\overline{U/D}$  toggling if, during  $\overline{CS}$  transition from High to Low, the  $\overline{U/D}$  input is High.

The wiper, when at either fixed terminal, acts like its mechanical equivalent and does not move beyond the last position. That is, the counter does not wrap around when clocked to either extreme.

If the wiper is moved several positions, multiple taps are connected to the wiper for  $t_{SETTLE}$  ( $\overline{U/D}$  to RH change). The 2-terminal resistance value for the device can temporarily change by a significant amount if the wiper is moved several positions.

## Revision History

The revision history provided is for informational purposes only and is believed to be accurate, but not warranted. Please go to the web to make sure that you have the latest revision.

DATE	REVISION	CHANGE
October 22, 2015	FN8225.4	Added Rev History and About Intersil Verbiage. Updated Ordering Information on page 2 Updated PODs to most recent revisions. Made correction to Pkg Dwg # in Ordering Information table "P5.046" to P5.064"

## About Intersil

Intersil Corporation is a leading provider of innovative power management and precision analog solutions. The company's products address some of the largest markets within the industrial and infrastructure, mobile computing and high-end consumer markets.

For the most updated datasheet, application notes, related documentation and related parts, please see the respective product information page found at [www.intersil.com](http://www.intersil.com).

You may report errors or suggestions for improving this datasheet by visiting [www.intersil.com/ask](http://www.intersil.com/ask).

Reliability reports are also available from our website at [www.intersil.com/support](http://www.intersil.com/support)

© Copyright Intersil Americas LLC 2005-2015. All Rights Reserved.  
All trademarks and registered trademarks are the property of their respective owners.

For additional products, see [www.intersil.com/en/products.html](http://www.intersil.com/en/products.html)

Intersil products are manufactured, assembled and tested utilizing ISO9001 quality systems as noted in the quality certifications found at [www.intersil.com/en/support/qualandreliability.html](http://www.intersil.com/en/support/qualandreliability.html)

*Intersil products are sold by description only. Intersil may modify the circuit design and/or specifications of products at any time without notice, provided that such modification does not, in Intersil's sole judgment, affect the form, fit or function of the product. Accordingly, the reader is cautioned to verify that datasheets are current before placing orders. Information furnished by Intersil is believed to be accurate and reliable. However, no responsibility is assumed by Intersil or its subsidiaries for its use; nor for any infringements of patents or other rights of third parties which may result from its use. No license is granted by implication or otherwise under any patent or patent rights of Intersil or its subsidiaries.*

For information regarding Intersil Corporation and its products, see [www.intersil.com](http://www.intersil.com)

# Package Outline Drawing

## P5.064

### 5 LEAD SMALL OUTLINE TRANSISTOR PLASTIC PACKAGE

Rev 3, 4/11

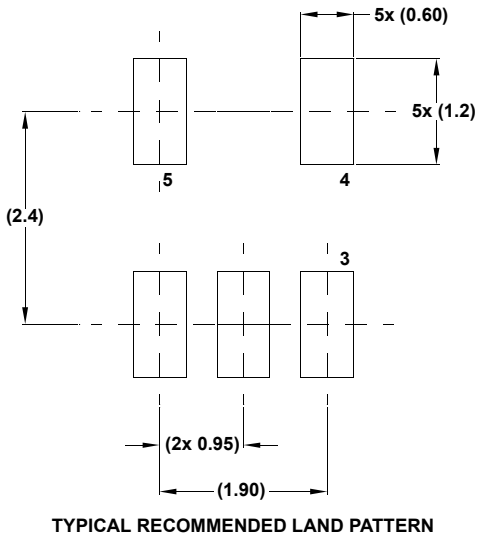
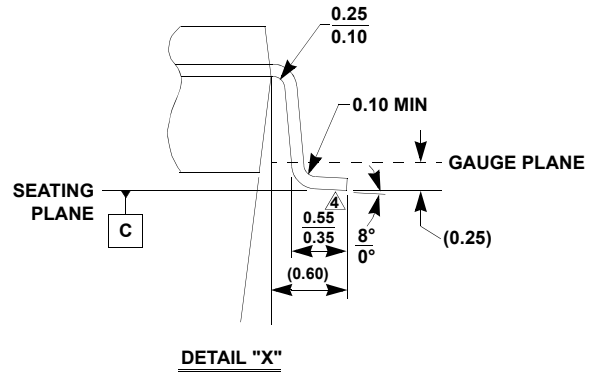
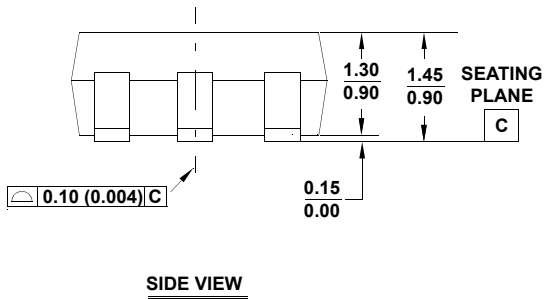
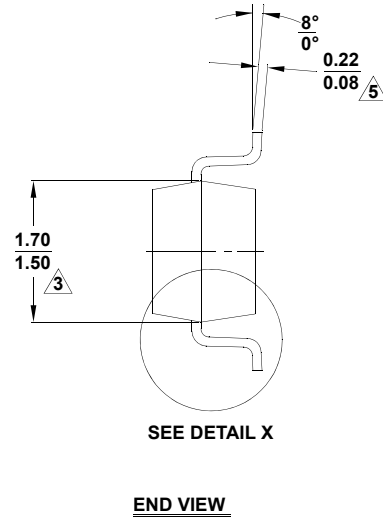
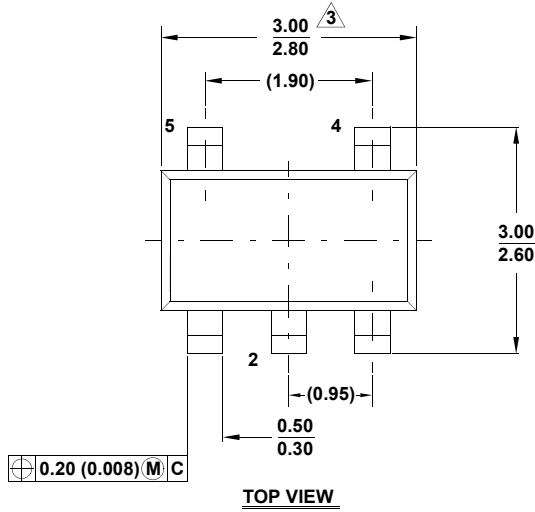

**NOTES:**

1. Dimensioning and tolerance per ASME Y14.5M-1994.
2. Package conforms to EIAJ SC-74 and JEDEC MO178AA.
3. Package length and width are exclusive of mold flash, protrusions, or gate burrs.
4. Footlength measured at reference to gauge plane.
5. Lead thickness applies to the flat section of the lead between 0.08mm and 0.15mm from the lead tip.
6. Controlling dimension: MILLIMETER.  
Dimensions in ( ) for reference only.

**Small Outline Transistor Plastic Packages (SC70-5)**

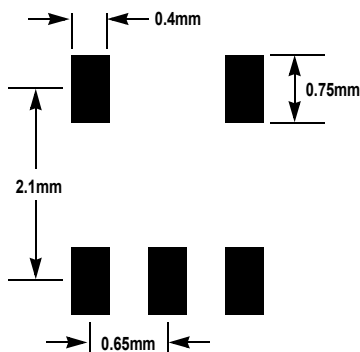
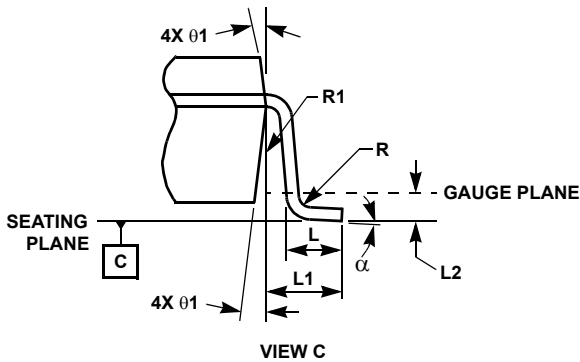
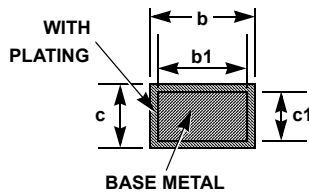
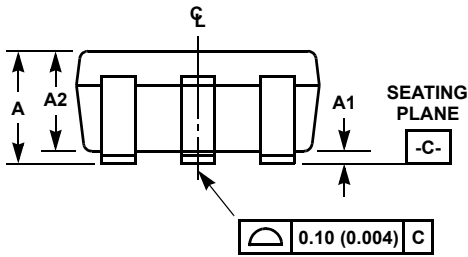
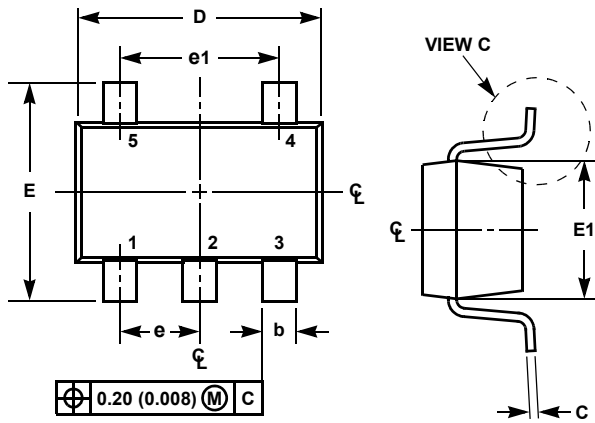

TYPICAL RECOMMENDED LAND PATTERN

**P5.049**

**5 LEAD SMALL OUTLINE TRANSISTOR PLASTIC PACKAGE**

SYMBOL	INCHES		MILLIMETERS		NOTES
	MIN	MAX	MIN	MAX	
A	0.031	0.043	0.80	1.10	-
A1	0.000	0.004	0.00	0.10	-
A2	0.031	0.039	0.80	1.00	-
b	0.006	0.012	0.15	0.30	-
b1	0.006	0.010	0.15	0.25	-
c	0.003	0.009	0.08	0.22	6
c1	0.003	0.009	0.08	0.20	6
D	0.073	0.085	1.85	2.15	3
E	0.071	0.094	1.80	2.40	-
E1	0.045	0.053	1.15	1.35	3
e	0.0256 Ref		0.65 Ref		-
e1	0.0512 Ref		1.30 Ref		-
L	0.010	0.018	0.26	0.46	4
L1	0.017 Ref.		0.420 Ref.		-
L2	0.006 BSC		0.15 BSC		-
α	0°	8°	0°	8°	-
N	5		5		5
R	0.004	-	0.10	-	-
R1	0.004	0.010	0.15	0.25	-

Rev. 3 7/07

**NOTES:**

1. Dimensioning and tolerances per ASME Y14.5M-1994.
2. Package conforms to EIAJ SC70 and JEDEC MO-203AA.
3. Dimensions D and E1 are exclusive of mold flash, protrusions, or gate burrs.
4. Footlength L measured at reference to gauge plane.
5. "N" is the number of terminal positions.
6. These Dimensions apply to the flat section of the lead between 0.08mm and 0.15mm from the lead tip.
7. Controlling dimension: MILLIMETER. Converted inch dimensions are for reference only.

## Looking for pricing, stock, or lifecycle information?

Click below to explore more details on WIN SOURCE:

 [View ISL90460WIH527Z-TK on WIN SOURCE](#)

 [Intersil Information](#)

## Optimize Your Supply Chain with WIN SOURCE Solutions

-  Global Sourcing Solution
-  Obsolete Management
-  Cost Control Management
-  Shortage Management
-  Alternative Solution
-  Excess Inventory Management