



THE DATASHEET OF APM4953



Features

$V_{DS} (V) = -30V$

$I_D = -5.3A (V_{GS} = 10V)$

$R_{DS(ON)} < 41m\Omega (V_{GS} = -10V)$

$R_{DS(ON)} < 75m\Omega (V_{GS} = -4.5V)$

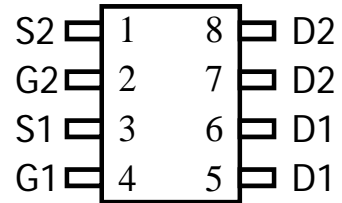
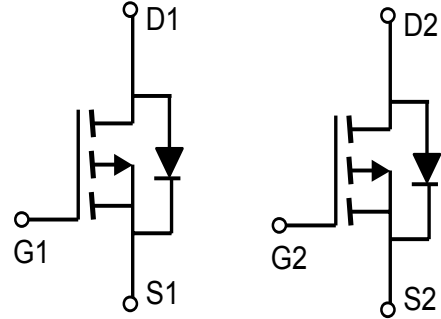

Absolute Maximum Ratings ($T_A=25^\circ C$, unless otherwise noted)

Symbol	Parameter	Ratings	Units
V_{DS}	Drain-Source Voltage	-30	V
V_{GS}	Gate-Source Voltage	± 20	V
I_D	Drain Current (Continuous)	-5.3	A
I_{DM}	Drain Current (Pulsed) ^a	-20	A
P_D	Total Power Dissipation @ $T_A=25^\circ C$	2.0	W
I_S	Maximum Diode Forward Current	-1.9	A
T_j, T_{stg}	Operating Junction and Storage Temperature Range	-55 to +150	$^\circ C$
$R_{\theta JA}$	Thermal Resistance Junction to Ambient (PCB mounted) ^b	50	$^\circ C/W$

a: Repetitive Rating: Pulse width limited by the maximum junction temperature.
b: 1-in² 2oz Cu PCB board

Electrical Characteristics ($T_A=25^{\circ}\text{C}$, unless otherwise noted)

Symbol	Characteristic	Test Conditions	Min.	Typ.	Max.	Unit
OFF CHARACTERISTICS						
BV_{DSS}	Drain-Source Breakdown Voltage	$V_{GS}=0V, I_D=-250\mu A$	-30	-	-	V
I_{DSS}	Zero Gate Voltage Drain Current	$V_{DS}=-24V, V_{GS}=0V$	-	-	-1	μA
I_{GSS}	Gate-Body Leakage Current	$V_{GS}=\pm 20V, V_{DS}=0V$	-	-	± 100	nA
ON CHARACTERISTICS^b						
$V_{GS(th)}$	Gate Threshold Voltage	$V_{DS}=V_{GS}, I_D=-250\mu A$	-1	-1.5	-2.5	V
$R_{DS(on)}$	Drain-Source On-State Resistance	$V_{GS}=-10V, I_D=-5.3A$	-	38	41	$m\Omega$
		$V_{GS}=-4.5V, I_D=-3.9A$	-	59	75	
g_{FS}	Forward Transconductance	$V_{DS}=-10V, I_D=-5.3A$	-	11	-	S
DYNAMIC CHARACTERISTICS^c						
C_{iss}	Input Capacitance	$V_{DS}=-15V, V_{GS}=0V, f=1MHz$	-	504	-	PF
C_{oss}	Output Capacitance		-	68	-	
C_{rss}	Reverse Transfer Capacitance		-	56	-	
SWITCHING CHARACTERISTICS^c						
Q_g	Total Gate Charge	$V_{DS}=-15V, I_D=-3.6A, V_{GS}=-10V$	-	12	-	nC
Q_{gs}	Gate-Source Charge		-	2.3	-	
Q_{gd}	Gate-Drain Charge		-	1.4	-	
$t_{d(on)}$	Turn-on Delay Time	$V_{DD}=-15V, R_L=5\Omega, I_D=-3A,$ $V_{GEN}=-10V, R_G=6\Omega$	-	8.1	-	nS
t_r	Turn-on Rise Time		-	3.3	-	
$t_{d(off)}$	Turn-off Delay Time		-	29.3	-	
t_f	Turn-off Fall Time		-	5.6	-	
Drain-Source Diode Characteristics						
V_{SD}	Drain-Source Diode Forward Voltage	$V_{GS}=0V, I_S=-1.9A$	-	-	-1.3	V

Note: Pulse Test: Pulse Width $\leq 300\mu s$, Duty Cycle $\leq 2\%$

Characteristics Curve

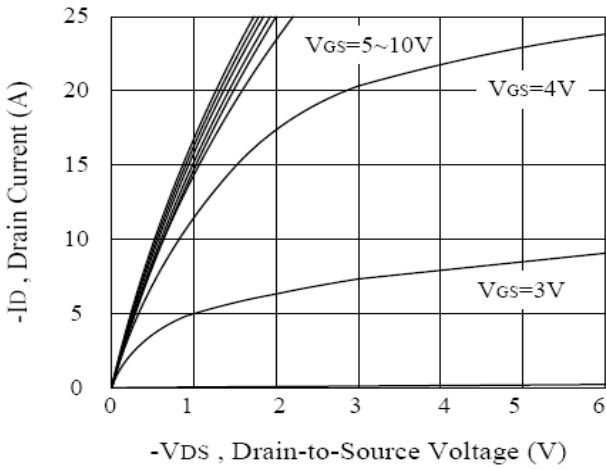

Figure 1. Output Characteristics

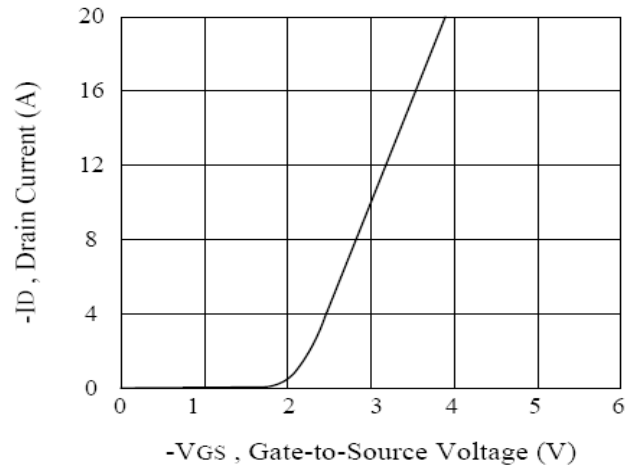

Figure 2. Transfer Characteristics

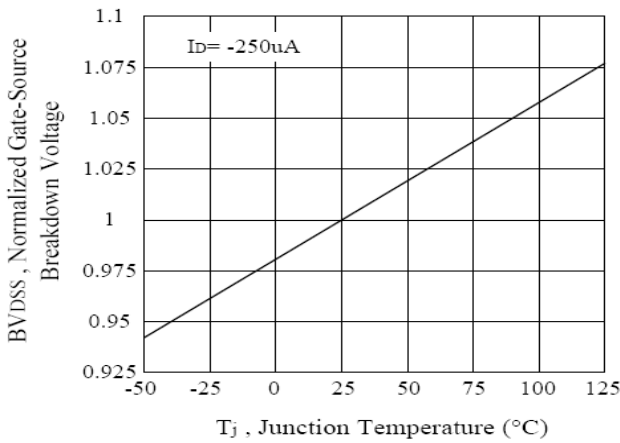

Figure 3. Breakdown Voltage Variation with Temperature

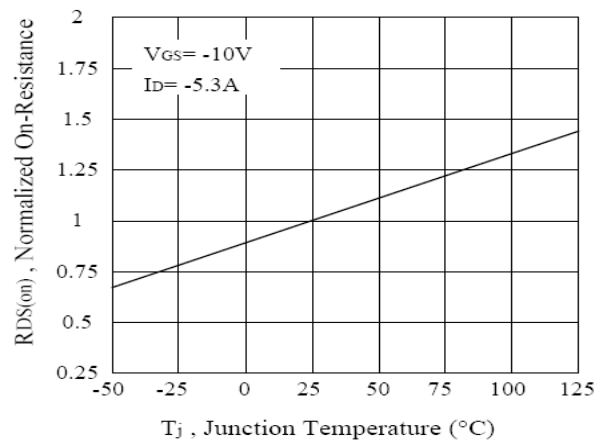

Figure 4. On-Resistance Variation with Temperature

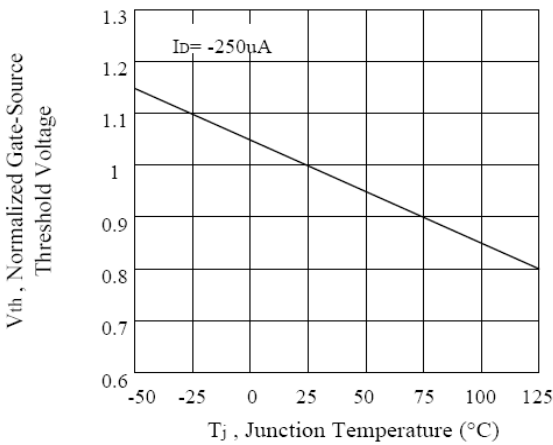

Figure 5. Gate Threshold Variation with Temperature

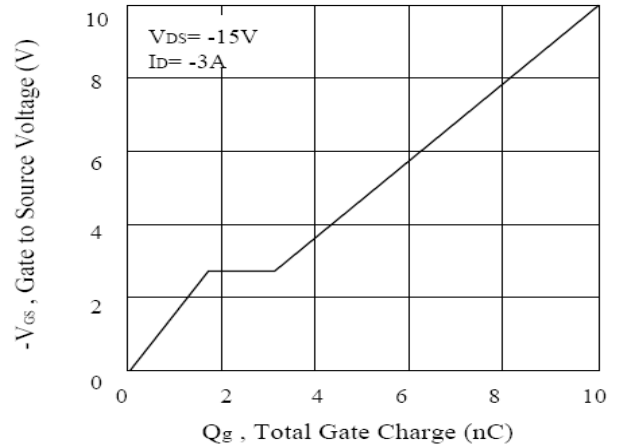
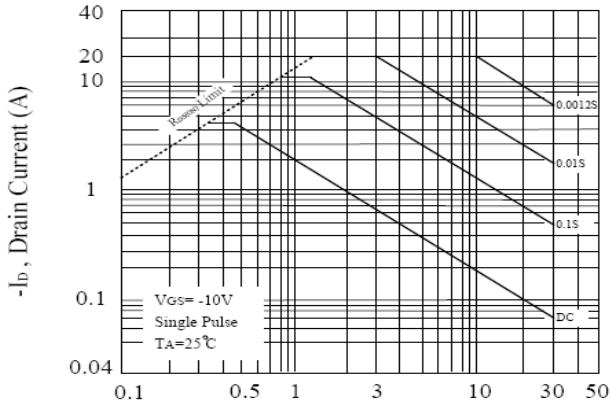
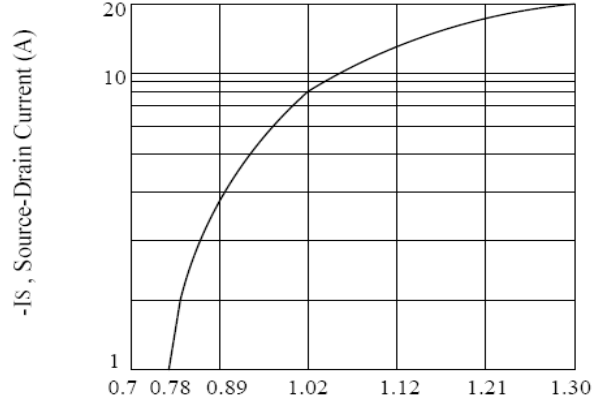

Figure 6. Gate Charge

Characteristics Curve



-VDS, Drain-Source Voltage (V)
Figure 7. Maximum Safe Operating Area



-VSD, Body Diode Forward Voltage (V)
Figure 8. Body Diode Forward Voltage Variation with Source Current

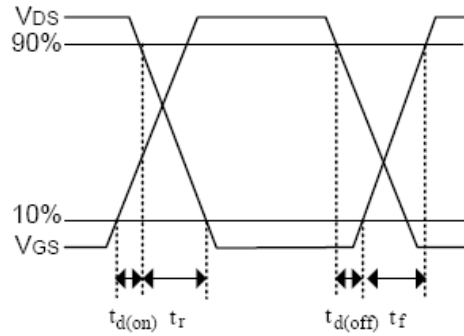
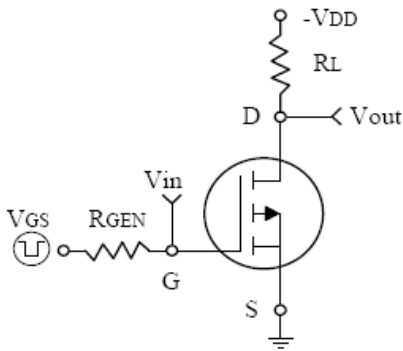

Switching Test Circuit and Switching Waveforms

PACKAGE OUTLINE DIMENSIONS

SOP-8

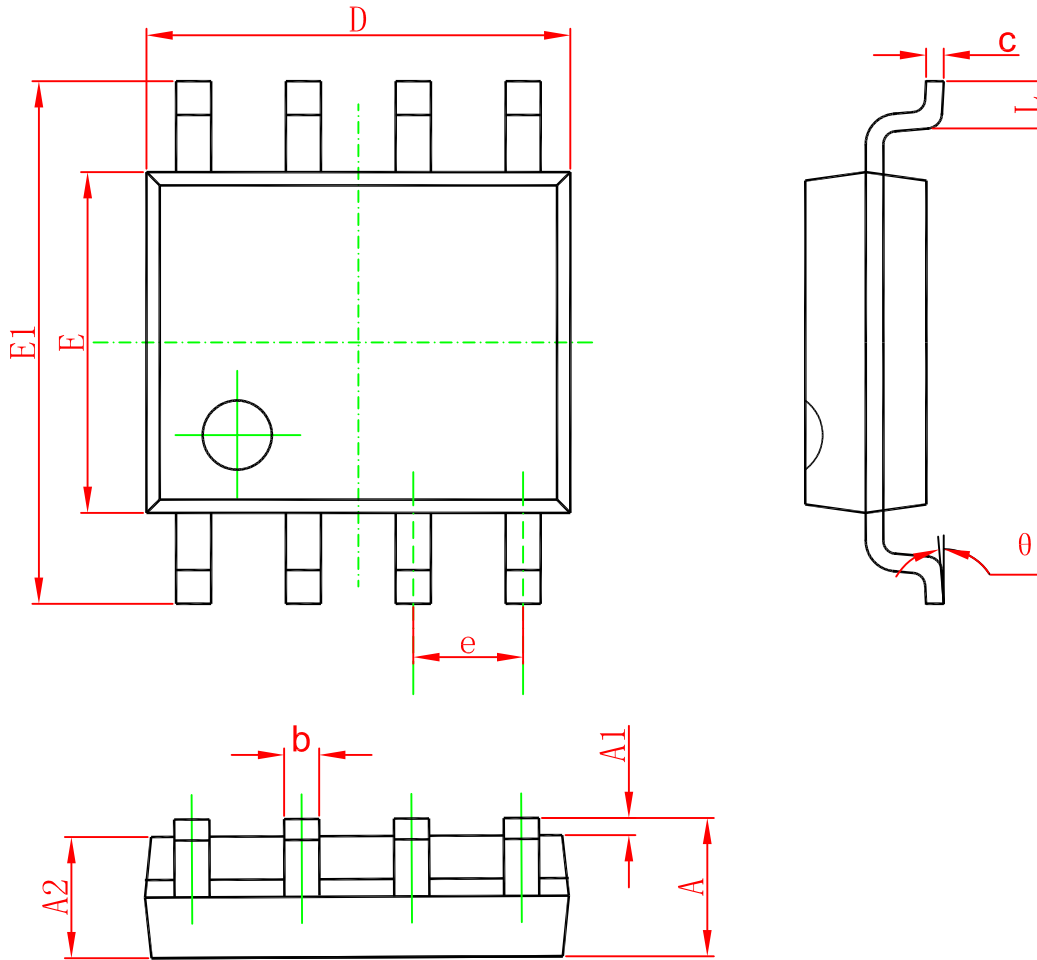

Symbol	Dimensions In Millimeters		Dimensions In Inches	
	Min	Max	Min	Max
A	1.350	1.750	0.053	0.069
A1	0.100	0.250	0.004	0.010
A2	1.350	1.550	0.053	0.061
b	0.330	0.510	0.013	0.020
c	0.170	0.250	0.006	0.010
D	4.700	5.100	0.185	0.200
E	3.800	4.000	0.150	0.157
E1	5.800	6.200	0.228	0.244
e	1.270(BSC)		0.050(BSC)	
L	0.400	1.270	0.016	0.050
θ	0°	8°	0°	8°

Marking

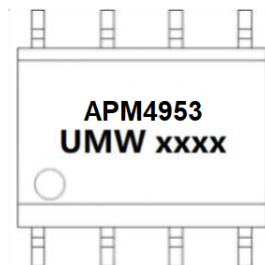



Ordering information

Order code	Package	Baseqty	Deliverymode
UMW APM4953	SOP-8	3000	Tape and reel

Looking for pricing, stock, or lifecycle information?

Click below to explore more details on WIN SOURCE:

-  [View APM4953 on WIN SOURCE](#)
-  [NXP / Nexperia Information](#)

Optimize Your Supply Chain with WIN SOURCE Solutions

-  Global Sourcing Solution
-  Obsolete Management
-  Cost Control Management
-  Shortage Management
-  Alternative Solution
-  Excess Inventory Management