



THE DATASHEET OF TPS65111RGER





LTPS-LCD BIAS POWER SUPPLY, TRIPLE CHARGE PUMP

FEATURES

- Complete LTPS-LCD Bias Solution
- Triple Output Charge Pump Providing V_{CC} at 16 mA, V_{DD} at 2 mA, V_{SS} at 1 mA
- 2.4 V to 5.5 V Input Voltage Range
- Fixed Output Voltages of 3.3 V, 7.5 V, -2.7 V or 5.0 V, 9.0 V, -3.0 V
- 50 μ A Typical Quiescent Current
- Less Than 1 μ A Shutdown Current
- Ultra-Low Ripple ($V_{CC} = 5$ mV, Typical at 5 mA)
- Autonomous Boost for V_{CC} Supply
- 1.5% Accuracy on Fixed V_{CC} Output Voltage
- Sequential Power Control
- 24-Pin QFN Package (4 x 4)

APPLICATIONS

- Small Form LTPS-LCD Displays
- PDAs, Pocket PCs
- Smart Phones

DESCRIPTION

The TPS65110/11 is a very compact power supply solution providing the three voltages required by many LTPS LCD displays.

All three regulated outputs are generated using a charge pump topology.

The V_{CC} charge pump provides precise, high efficiency, and very low ripple dc/dc conversion for the LCD analog power. The V_{CC} boost ratio (x1.0, x1.33, x1.5, and x2.0) is automatically set based on input and output voltage conditions. The V_{CC} output assures 16 mA of current by using three 0.22- μ F flying capacitors. If the required output current is smaller, smaller capacitors can be applied.

The V_{DD} charge pump provides a higher positive voltage, and the V_{SS} charge pump provides the negative output voltage. Power up/down sequences are internally set and are secured even in cases of sudden and abnormal V_{IN} drop.

One of the most significant features of the TPS65110/11 is the ultra-low output voltage ripple, as the V_{CC} charge pump achieves 5-mV output ripple voltage.

APPLICATION CIRCUIT FOR TPS65111

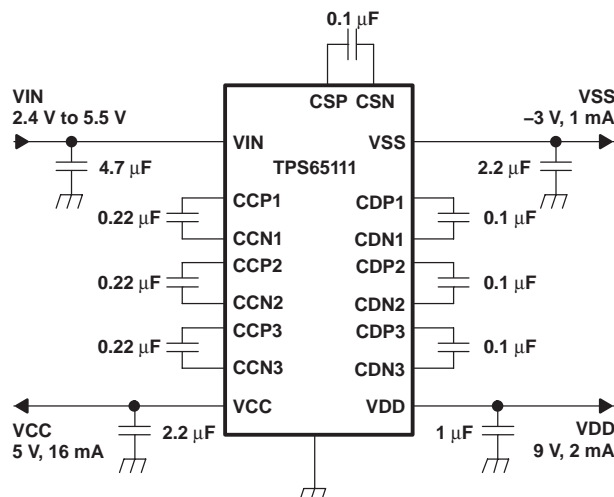

AVAILABLE OUTPUT VOLTAGE OPTIONS

PART NUMBER	V_{CC}	V_{DD}	V_{SS}	V_{DD} BOOST
TPS65110RGE	3.3 V	7.5 V	-2.7 V	X3
TPS65111RGE	5.0 V	9.0 V	-3.0 V	X2

- (1) The RGE package is available in tape and reel.
Add R suffix (RGER) to order quantities of 3000 parts.



Please be aware that an important notice concerning availability, standard warranty, and use in critical applications of Texas Instruments semiconductor products and disclaimers thereto appears at the end of this data sheet.



These devices have limited built-in ESD protection. The leads should be shorted together or the device placed in conductive foam during storage or handling to prevent electrostatic damage to the MOS gates.

ABSOLUTE MAXIMUM RATINGS

over operating free-air temperature range unless otherwise noted⁽¹⁾

	UNIT
Supply voltage at VIN (2)	-0.3 V to 7.0 V
Input voltage at EN, CLK, DATA (2)	-0.3 V to VIN + 0.3 V
Power dissipation (3)	46°C/W
Virtual operation junction temperature, T _J	-40°C to 125°C
Storage temperature range	-65°C to 150°C
Lead temperature 1,6 mm (1/16 inch) from case for 10 seconds	260°C

(1) Stresses beyond those listed under “absolute maximum ratings” may cause permanent damage to the device. These are stress ratings only, and functional operation of the device at these or any other conditions beyond those indicated under “recommended operating conditions” is not implied. Exposure to absolute-maximum-rated conditions for extended periods may affect device reliability.

(2) All voltage values are with respect to network ground terminal.

(3) The package thermal impedance is calculated in accordance with JESD 51-5.

CHANNEL PERFORMANCE OVERVIEW

CHANNEL	VCC	VDD	VSS
Output Voltage Control	Regulated	Regulated	Regulated
Boost Ratio	x1; x1.333; x1.5; x2	x2 or x3	x-1
Boost setting	Autonomous Boost	Fixed	Fixed
Power Supply	VIN	VCC	VCC
Output Current	16 mA	2 mA	1 mA
Accuracy	±1.5%	±3%	±3%
Num of Ext CAP	4	4	2

RECOMMENDED OPERATING CONDITIONS

	MIN	NOM	MAX	UNIT
Input voltage range, VIN	2.4		5.5	V
Main output voltage, V _{CC}	3.0		5.2	V
Positive output voltage range, V _{DD}	6.5		10	V
Negative output voltage range, V _{SS}	-4.5		-2.4	V
VIN input capacitor(C _i)		4.7		μF
V _{CC} output capacitor(C _{CO})		2.2		μF
V _{DD} output capacitor(C _{DO})		1.0		μF
V _{SS} output capacitor(C _{SO})		2.2		μF
V _{CC} flying capacitors(C _{C1} , C _{C2} , C _{C3})		0.22		μF
V _{DD} and V _{SS} flying capacitors(C _{D1} , C _{D2} , C _{D3} , C _S)		0.1		μF
Operating ambient temperature, T _A	-40		85	°C
Operating junction temperature, T _J	-40		125	°C

ELECTRICAL CHARACTERISTICS

over recommended free-air temperature, typical at an ambient temperature of 25°C, at $C_{C1}=C_{C2}=C_{C3}=0.22\ \mu\text{F}$, $C_{D1}=C_{D2}=C_{D3}=C_S=0.1\ \mu\text{F}$, $C_{C0}=C_{S0}=2.2\ \mu\text{F}$, $C_{D0}=1.0\ \mu\text{F}$, $V_I=3.6\ \text{V}$, and default output voltages (unless otherwise noted)

PARAMETER		TEST CONDITIONS	MIN	TYP	MAX	UNIT
DEVICE						
V_I	Input voltage range		2.4		5.5	V
I_Q	Operating quiescent current	$V_I = 2.8\ \text{V}$, $EN = V_I$, $SCLK = DATA = VROM = GND$, No load		50	120	μA
I_{SD}	Shutdown supply current	$V_I = 2.8\ \text{V}$, $EN = GND$, $SCLK = DATA = VROM = GND$			1	μA
f_{max}	Maximum operating frequency		320	400	520	kHz
V_{UVLO}	Under-voltage lockout threshold	$V_I = 0\ \text{V}$ to $3.6\ \text{V}$	2.1	2.3	2.5	V
		$V_I = 3.6\ \text{V}$ to $0\ \text{V}$	2.0	2.2	2.4	
	Hysteresis		30	100		mV
LOGIC SECTION						
V_{IH}	EN/CLK/DATA high level input voltage	$V_I = 2.4\ \text{V}$ to $3.5\ \text{V}$	1.3			V
		$V_I = 3.5\ \text{V}$ to $5.5\ \text{V}$	1.5			
V_{IL}	EN/CLK/DATA low level input voltage				0.4	V
I_{IH} / I_{IL}	Logic input current	$EN = GND$ or V_I		0.01	0.1	μA
TPS65110 OUTPUT (V_{CC}, V_{DD}, V_{SS})						
V_{CC}	V_{CC} Output DC voltage range	$V_I = 2.8\ \text{V}$, $I_{VCC} = 5\ \text{mA}$	3.25	3.3	3.35	V
I_{VCC}	V_{CC} Output current	$I_{VDD} = 2\ \text{mA}$, $I_{VSS} = 1\ \text{mA}$	16			mA
$V_{RIPPLEC}$	V_{CC} Output voltage ripple	$I_{VCC} = 5\ \text{mA}$		5		mV
V_{REGC}	V_{CC} Line regulation	$V_I = 2.4\ \text{V}$ to $5.5\ \text{V}$		0.1	0.5	%/V
L_{REGC}	V_{CC} Load regulation	$V_I = 2.8\ \text{V}$, $I_{VCC} = \text{no load to } 10\ \text{mA}$		0.3	1	%
t_{rC}	V_{CC} Rise time	10% to 90%, no load		100		μs
t_{fC}	V_{CC} Fall time	90% to 10%, no load		6		mS
	V_{CC} Efficiency	V_I to V_{CC} , $V_{CC} = 3.3\ \text{V}$, $I_{VCC} = 1\ \text{mA}$		84%		
		V_I to V_{CC} , $V_{CC} = 3.3\ \text{V}$, $I_{VCC} = 10\ \text{mA}$		86%		
V_{DD}	V_{DD} Output DC voltage range	$V_{CC} = 3.3\ \text{V}$, $I_{VDD} = 1.0\ \text{mA}$, V_{DD} boost = x3	7.27	7.5	7.73	V
I_{VDD}	V_{DD} Output current	$V_{CC} = 3.3\ \text{V}$	2			mA
$V_{RIPPLED}$	V_{DD} Output voltage ripple	$I_{VDD} = 1\ \text{mA}$		7		mV
t_{rD}	V_{DD} Rise time	10% to 90%, no load		1.4		mS
t_{fD}	V_{DD} Fall time	90% to 10%, no load		2.4		mS
	V_{DD} Efficiency	V_{CC} to V_{DD} , $V_{CC} = 3.3\ \text{V}$, $V_{DD} = 7.5\ \text{V}$, $I_{VDD} = 0.2\ \text{mA}$		70%		
		V_{CC} to V_{DD} , $V_{CC} = 3.3\ \text{V}$, $V_{DD} = 7.5\ \text{V}$, $I_{VDD} = 2\ \text{mA}$		70%		
V_{SS}	V_{SS} Output DC voltage range	$V_{CC} = 3.3\ \text{V}$, $I_{VSS} = 0.2\ \text{mA}$	-2.78	-2.7	-2.62	V
I_{VSS}	V_{SS} Output current	$V_{CC} = 3.3\ \text{V}$	1			mA
$V_{RIPPLES}$	V_{SS} Output voltage ripple	$I_{VSS} = 0.2\ \text{mA}$		3		mV
t_{rS}	V_{SS} Rise time	10% to 90%, no load		220		μs
t_{fS}	V_{SS} Fall time	90% to 10%, no load		2		mS
	V_{SS} Efficiency	V_{CC} to V_{SS} , $V_{CC} = 3.3\ \text{V}$, $V_{SS} = -2.8\ \text{V}$, $I_{VSS} = 0.2\ \text{mA}$		82%		
		V_{CC} to V_{SS} , $V_{CC} = 3.3\ \text{V}$, $V_{SS} = -2.8\ \text{V}$, $I_{VSS} = 1\ \text{mA}$		82%		

ELECTRICAL CHARACTERISTICS Continued

over recommended free-air temperature, typical at an ambient temperature of 25°C, at $C_C1=C_C2=C_C3=0.22\ \mu\text{F}$, $C_D1=C_D2=C_D3=C_S=0.1\ \mu\text{F}$, $C_{CO}=C_{SO}=2.2\ \mu\text{F}$, $C_{DO}=1.0\ \mu\text{F}$, $V_I=3.6\ \text{V}$, and default output voltages (unless otherwise noted)

TPS65111 OUTPUT (V_{CC} , V_{DD} , V_{SS})						
V_{CC}	V_{CC} Output dc voltage range	$V_I = 3.6\ \text{V}$, $I_{VCC} = 5\ \text{mA}$	4.925	5.0	5.075	V
I_{VCC}	Maximum V_{CC} output current	$I_{VDD} = 2\ \text{mA}$, $I_{VSS} = 1\ \text{mA}$	16			mA
$V_{RIPPLEC}$	V_{CC} Output voltage ripple	$I_{VCC} = 5\ \text{mA}$		5		mV
V_{REGC}	V_{CC} Line regulation	$V_I = 2.7\ \text{V}$ to $5.5\ \text{V}$		0.1	0.5	%/V
L_{REGC}	V_{CC} Load regulation	$V_I = 3.6\ \text{V}$, $I_{VCC} = \text{no load to } 10\ \text{mA}$		0.3	1	%
t_{rC}	V_{CC} Rise time	10% to 90%, no load		200		μS
t_{fC}	V_{CC} Fall time	90% to 10%, no load		9		mS
	V_{CC} Efficiency	V_I to V_{CC} , $V_{CC} = 5.0\ \text{V}$, $I_{VCC} = 1\ \text{mA}$		88%		
		V_I to V_{CC} , $V_{CC} = 5.0\ \text{V}$, $I_{VCC} = 10\ \text{mA}$		90%		
V_{DD}	V_{DD} Output dc voltage range	$V_{CC} = 5.0\ \text{V}$, $I_{VDD} = 1.0\ \text{mA}$, V_{DD} boost = x2	8.73	9.0	9.27	V
I_{VDD}	Maximum V_{DD} output current	$V_{CC} = 5.0\ \text{V}$	2			mA
$V_{RIPPLED}$	V_{DD} Output voltage ripple	$I_{VDD} = 1\ \text{mA}$		8		mV
t_{rD}	V_{DD} Rise time	10% to 90%, no load		1.8		mS
t_{fD}	V_{DD} Fall time	90% to 10%, no load		3		mS
	V_{DD} Efficiency	V_{CC} to V_{DD} , $V_{CC} = 5.0\ \text{V}$, $V_{DD} = 9.0\ \text{V}$, $I_{VDD} = 0.2\ \text{mA}$		87%		
		V_{CC} to V_{DD} , $V_{CC} = 5.0\ \text{V}$, $V_{DD} = 9.0\ \text{V}$, $I_{VDD} = 2\ \text{mA}$		88%		
V_{SS}	V_{SS} Output dc voltage range	$V_{CC} = 5.0\ \text{V}$, $I_{VSS} = 0.2\ \text{mA}$	-3.09	-3.0	-2.91	V
I_{VSS}	Maximum V_{SS} output current	$V_{CC} = 5.0\ \text{V}$	1			mA
$V_{RIPPLES}$	V_{SS} Output voltage ripple	$I_{VSS} = 0.2\ \text{mA}$		3		mV
t_{rS}	V_{SS} Rise time	10% to 90%, no load		250		μS
t_{fS}	V_{SS} Fall time	90% to 10%, no load		2.4		mS
	V_{SS} Efficiency	V_{CC} to V_{SS} , $V_{CC} = 5.0\ \text{V}$, $V_{SS} = -3.0\ \text{V}$, $I_{VSS} = 0.2\ \text{mA}$		58%		
		V_{CC} to V_{SS} , $V_{CC} = 5.0\ \text{V}$, $V_{SS} = -3.0\ \text{V}$, $I_{VSS} = 1\ \text{mA}$		58%		

PIN ASSIGNMENTS

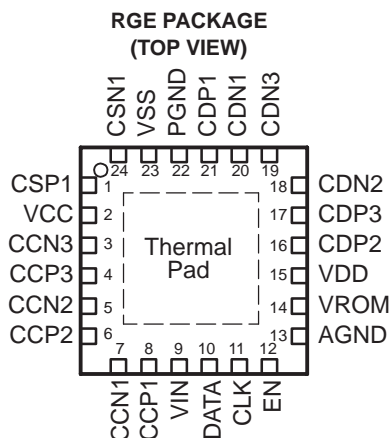

Terminal Functions

TERMINAL		DESCRIPTION
NO.	NAME	
1	CSP1	VSS Positive terminal for CS
2	VCC	VCC Charge pump output
3	CCN3	VCC Negative terminal for CC3
4	CCP3	VCC Positive terminal for CC3
5	CCN2	VCC Negative terminal for CC2
6	CCP2	VCC Positive terminal for CC2
7	CCN1	VCC Negative terminal for CC1
8	CCP1	VCC Positive terminal for CC1
9	VIN	Input supply voltage
10	DATA	I ² C serial data input
11	CLK	I ² C serial clock input
12	EN	Power on/off enable logic input (H : active / L : shutdown)
13	AGND	Analog GND
14	VROM	EEPROM power supply
15	VDD	VDD Charge pump output
16	CDP2	VDD Positive terminal for CD2
17	CDP3	VDD Positive terminal for CD3
18	CDN2	VDD Negative terminal for CD2
19	CDN3	VDD Negative terminal for CD3
20	CDN1	VDD Negative terminal for CD1
21	CDP1	VDD Positive terminal for CD1
22	PGND	Power GND
23	VSS	VSS Charge pump output
24	CSN1	VSS Negative terminal for CS

FUNCTIONAL BLOCK DIAGRAM

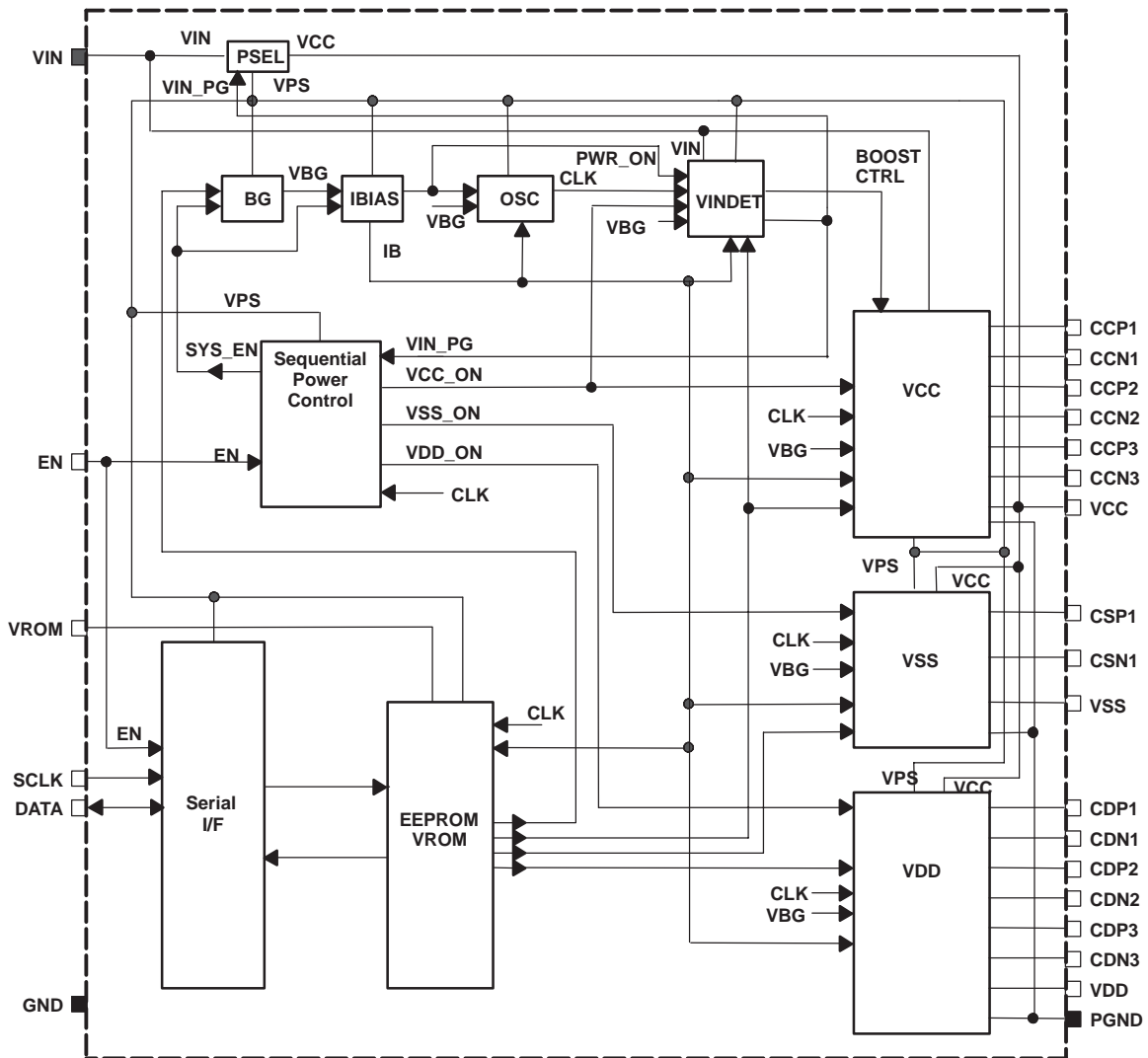

TYPICAL APPLICATION CIRCUIT

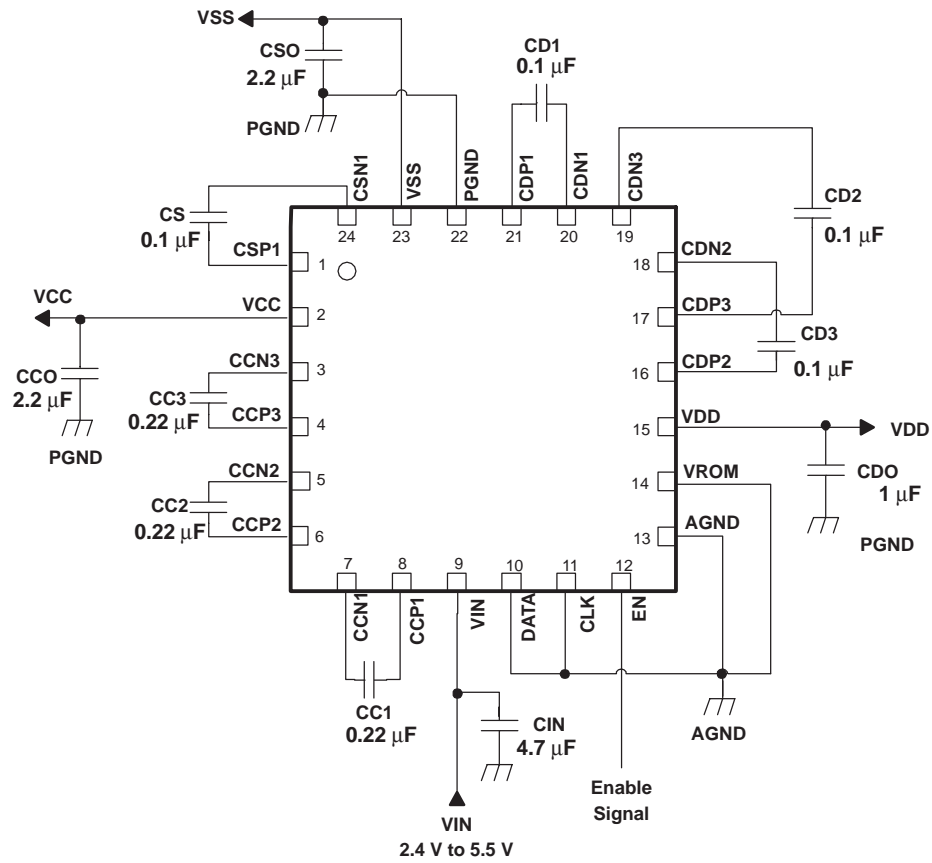

TYPICAL CHARACTERISTICS

VCC EFFICIENCY

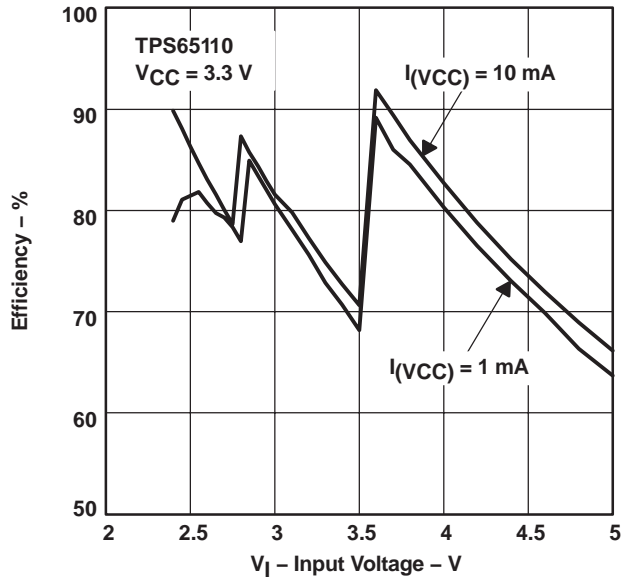

Figure 1

VCC EFFICIENCY

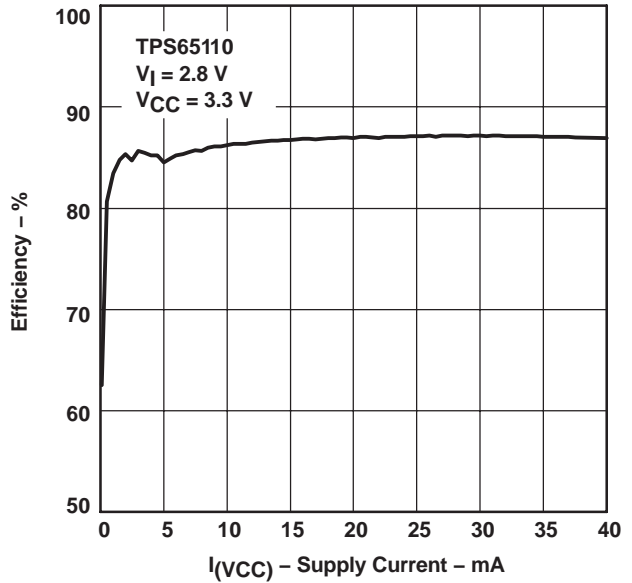

Figure 2

VCC LOAD REGULATION

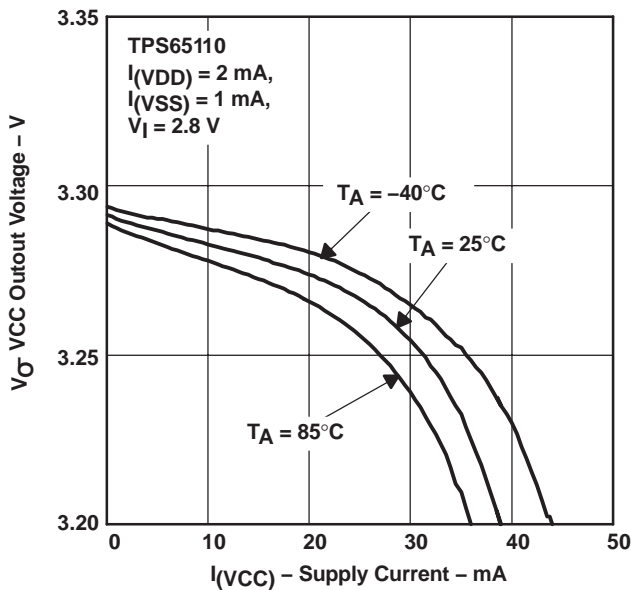

Figure 3

VCC LOAD REGULATION

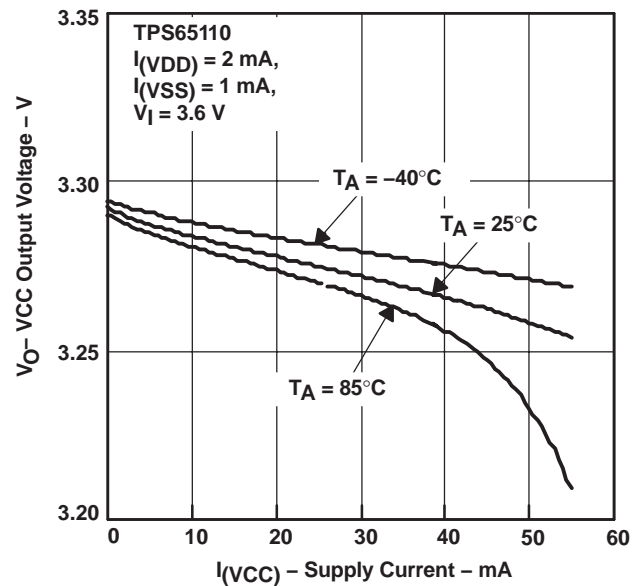

Figure 4

VDD LOAD REGULATION

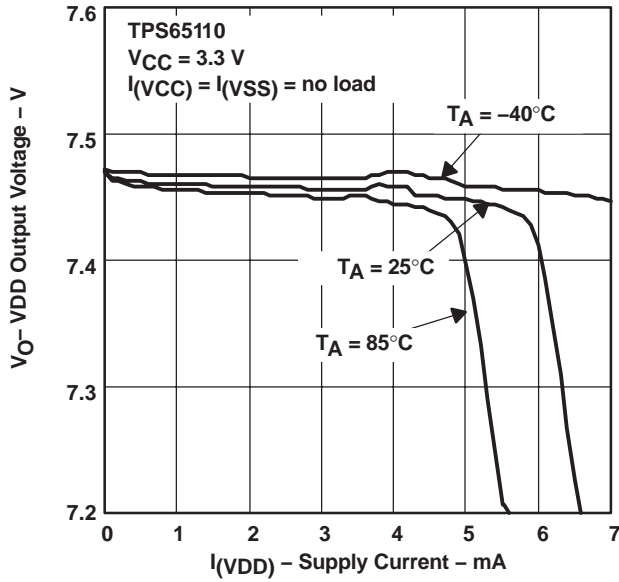

Figure 5

VSS LOAD REGULATION

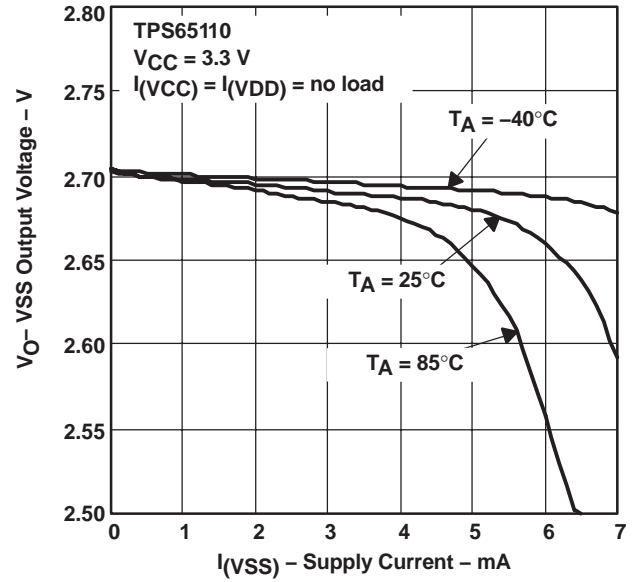

Figure 6

MAXIMUM SWITCHING FREQUENCY
vs
INPUT VOLTAGE

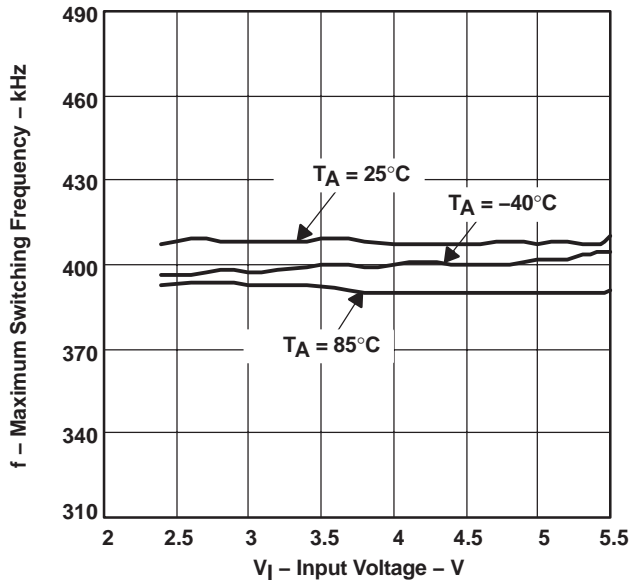

Figure 7

QUIESCENT CURRENT
vs
INPUT VOLTAGE

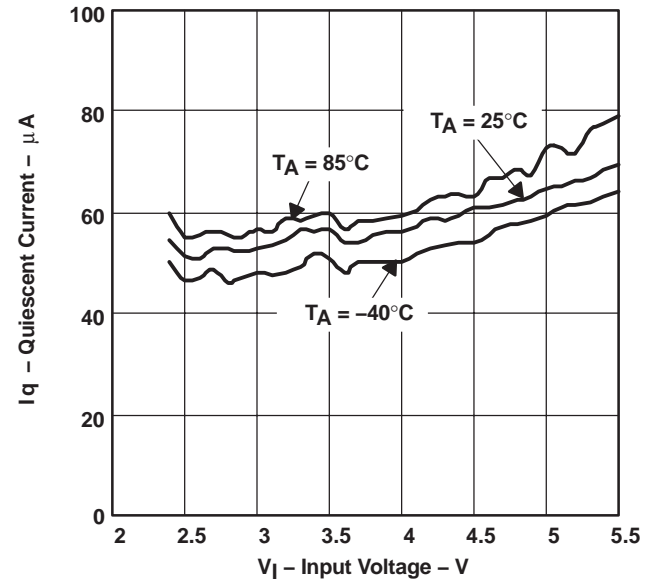
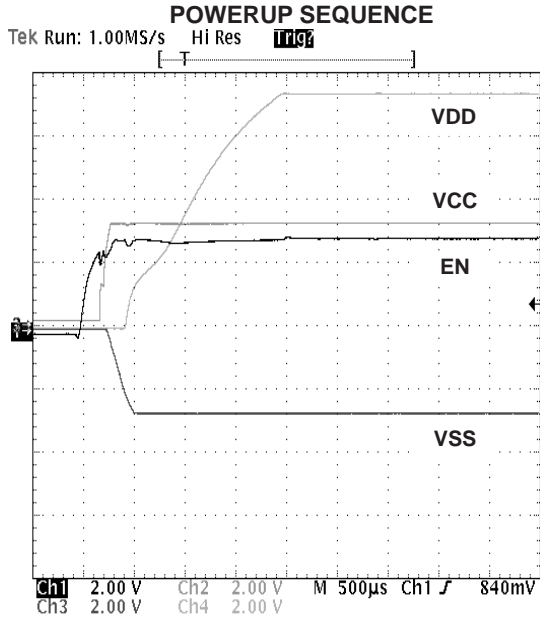
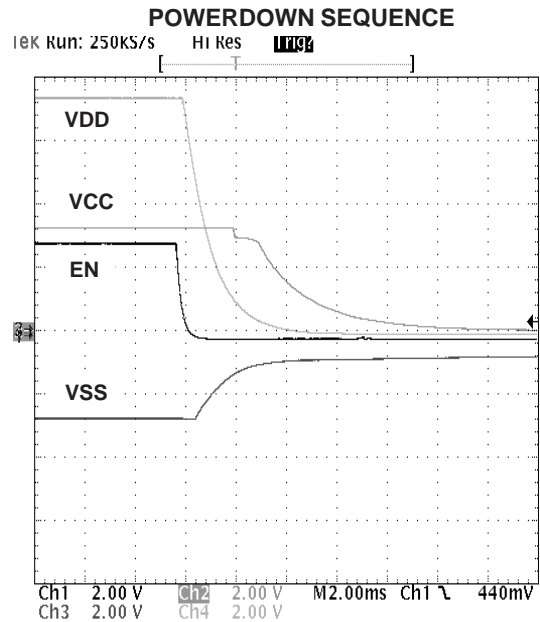

Figure 8



($V_I = 3.0\text{ V}$, $V_{CC} = 3.3\text{ V}$, $V_{DD} = 7.5\text{ V}$, $V_{SS} = -2.7\text{ V}$, $V_{DDBOOST} = \times 3$,
No load, $C_{C1/2/3} = 0.22\text{ }\mu\text{F}$, $C_{CO} = 2.2\text{ }\mu\text{F}$)

Figure 9



($V_I = 3.0\text{ V}$, $V_{CC} = 3.3\text{ V}$, $V_{DD} = 7.5\text{ V}$, $V_{SS} = -2.7\text{ V}$, $V_{DDBOOST} = \times 3$,
No load, $C_{C1/2/3} = 0.22\text{ }\mu\text{F}$, $C_{CO} = 2.2\text{ }\mu\text{F}$)

Figure 10

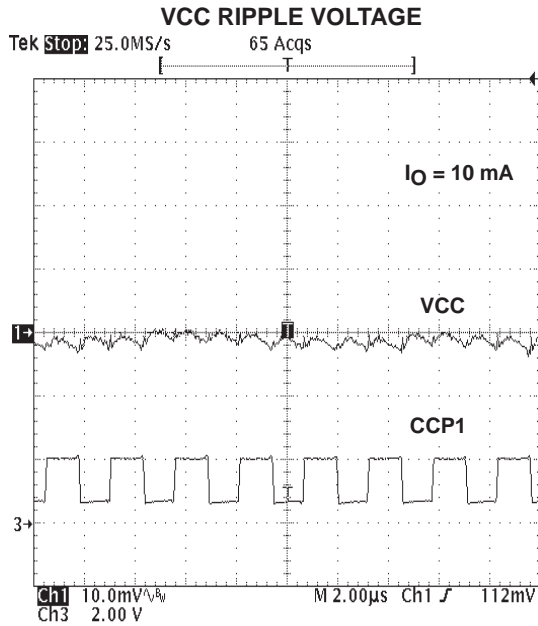

($V_I = 2.7\text{ V}$, $V_{CC} = 3.3\text{ V}$, $T_A = 25^\circ\text{C}$, $C_{C1/2/3} = 0.1\text{ }\mu\text{F}$,
 $C_{CO} = 2.2\text{ }\mu\text{F}$)

Figure 11

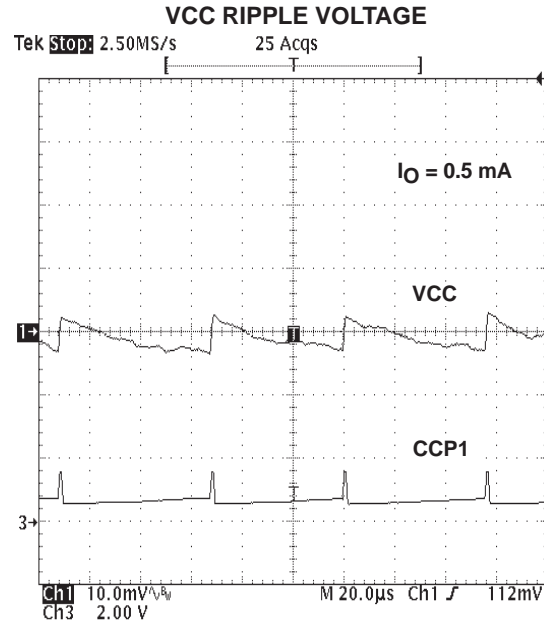

($V_I = 2.7\text{ V}$, $V_{CC} = 3.3\text{ V}$, $T_A = 25^\circ\text{C}$, $C_{C1/2/3} = 0.1\text{ }\mu\text{F}$,
 $C_{CO} = 2.2\text{ }\mu\text{F}$)

Figure 12

DETAILED DESCRIPTION

VCC Charge Pump

The VCC output provides a very high efficiency, regulated, dc/dc conversion through a wide input range by supporting x1.0, x1.33, x1.5, and x2.0 boost charge pump operation. TPS65110 automatically sets the boost ratio based on input and output voltage conditions. For example, when the input voltage from a battery becomes lower, the device automatically increases the boost ratio from x1.33 to x1.5. In a fixed input voltage mode, the device provides for higher conversion efficiency; for example, in the case of 2.8 V to 3.3 V conversion or 2.8 V to 5.0 V conversion. In this case, the VCC charge pump can enter into a *SKIP* mode operation in order to maintain the efficiency of a low load condition. The highest frequency of the charge pump is 400 kHz (typ). The charge pump operates by using higher frequencies in the heavier load current conditions, and decreases the frequency in the lighter load conditions. Maximum output current and operating frequency characteristics are dependent on external conditions such as the flying capacitor, output capacitor, and ambient temperature range.

VCC[V]	VIN [V]																										
	2.4	2.5	2.6	2.7	2.8	2.9	3.0	3.1	3.2	3.3	3.4	3.5	3.6	3.7	3.8	3.9	4.0	4.1	4.2	4.4	4.6	4.8	5.0	5.2	5.4	5.5	
3.3	x1.5			x1.33									x1														
5.0	NA			x2									x1.5				x1.33						x1				

NOTE: Gray portion is HYSTERESIS.

Of importance, the VCC charge pump is also used as the power source for the VDD and VSS charge pumps. Therefore, consider a case where the VDD charge pump's output current is required to be 2mA, and the boost ratio is x3. With this condition, the required (additional) current for the VCC output is slightly more than 6 mA. If the VSS charge pump output current requirement is 1 mA, then the (additional) required current from VCC is another 1 mA. (Note: the VCC charge pump maintains a minimum of 16-mA output capability in addition to the loads required to support the VDD and VSS charge pumps under the recommended conditions.)

VDD Charge Pump

The power source for the VDD charge pump is the VCC charge pump. The output voltage and boost ratio of the VDD charge pump are fixed at either a 7.5 V and x3 boost (TPS65110), or a 9.0 V and x2 boost (TPS65111). The topology of this charge pump is *SKIP mode*, and the maximum frequency is 400 kHz. Maximum output current is dependent on the flying capacitors and ambient temperature range (refer to the typical characteristics).

VSS Charge Pump

The VSS charge pump is powered from the VCC charge pump and has a fixed output voltage of either -2.7 V (TPS65110) or -3.0 V (TPS65111). The boost ratio for the VSS charge pump is fixed at x-1. The operation topology is *SKIP mode* and has a maximum frequency of 400 kHz. Maximum output current is dependent on the flying capacitor and ambient temperature range (refer to the typical characteristics).

UVLO – Under Voltage Lockout

The UVLO provides for the save operation of the device. It prevents the converter from turning on when the voltage on the VIN pin is less than the threshold voltage of UVLO. Note that although the input voltage range of the product is shown to be down to 2.4 V, the maximum threshold of the UVLO for a rising VIN is 2.5 V. Therefore, to operate down to 2.4 V, the device must first be powered by a source of more than 2.5 V.

Enable

Low logic on the EN pin forces the TPS6511x into shutdown mode. In shutdown, the power switch, drivers, voltage reference, oscillator, and all other functions are turned off. The supply current is reduced to less than 1 μ A in shutdown mode.

Power-Up and Power-Down Sequencing

The TPS65110/11 controls power-up and power-down sequence through an enable pin. This signal should be terminated and not be left floating to prevent miss-operation.

Power-Up Sequence

When the enable pin EN is pulled high, the device starts its power on sequencing. The VCC output starts up first. When the output voltage VCC has reached 75% of its nominal value, the VSS output comes up next. When VSS has reached 75% of the nominal value, the positive output VDD finally comes up.

Power-Down Sequencing

When the enable pin EN is pulled low, the device starts its power-down sequencing. The VDD output goes down first. When the output voltage VDD has reached 70% of its nominal value, the VSS output goes down next. When VSS has reached 70% of the nominal value, the positive output VCC finally goes down. The TPS6511x ensures this power-down sequence even in the case of a sudden V_I drop.

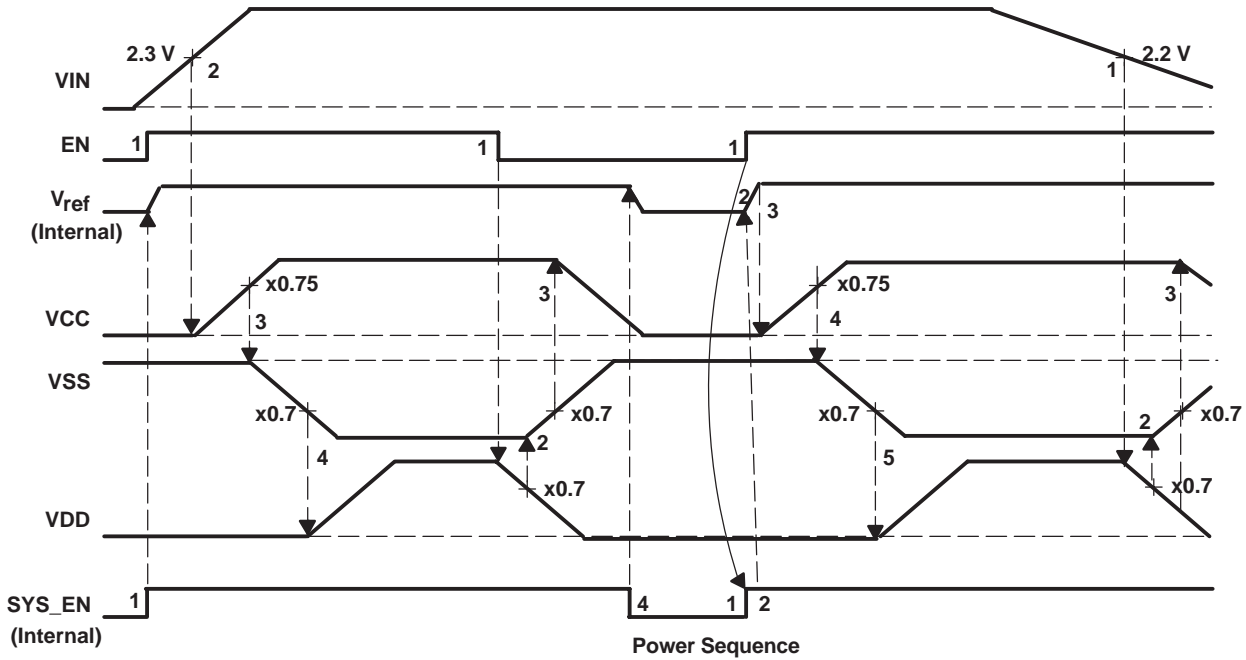

PACKAGING INFORMATION

Orderable Device	Status ⁽¹⁾	Package Type	Package Drawing	Pins	Package Qty	Eco Plan ⁽²⁾	Lead/ Ball Finish	MSL Peak Temp ⁽³⁾	Samples (Requires Login)
TPS65110RGE	ACTIVE	VQFN	RGE	24	92	Green (RoHS & no Sb/Br)	CU NIPDAU	Level-2-260C-1 YEAR	Request Free Samples
TPS65110RGE G3	ACTIVE	VQFN	RGE	24	92	Green (RoHS & no Sb/Br)	CU NIPDAU	Level-2-260C-1 YEAR	Request Free Samples
TPS65110RGER	ACTIVE	VQFN	RGE	24	3000	Green (RoHS & no Sb/Br)	CU NIPDAU	Level-2-260C-1 YEAR	Request Free Samples
TPS65110RGER G4	ACTIVE	VQFN	RGE	24	3000	Green (RoHS & no Sb/Br)	CU NIPDAU	Level-2-260C-1 YEAR	Request Free Samples
TPS65111RGE	ACTIVE	VQFN	RGE	24	92	Green (RoHS & no Sb/Br)	CU NIPDAU	Level-2-260C-1 YEAR	Purchase Samples
TPS65111RGE G4	ACTIVE	VQFN	RGE	24	92	Green (RoHS & no Sb/Br)	CU NIPDAU	Level-2-260C-1 YEAR	Purchase Samples
TPS65111RGER	ACTIVE	VQFN	RGE	24		Green (RoHS & no Sb/Br)	CU NIPDAU	Level-2-260C-1 YEAR	Purchase Samples
TPS65111RGER G4	ACTIVE	VQFN	RGE	24		Green (RoHS & no Sb/Br)	CU NIPDAU	Level-2-260C-1 YEAR	Purchase Samples

⁽¹⁾ The marketing status values are defined as follows:

ACTIVE: Product device recommended for new designs.

LIFEBUY: TI has announced that the device will be discontinued, and a lifetime-buy period is in effect.

NRND: Not recommended for new designs. Device is in production to support existing customers, but TI does not recommend using this part in a new design.

PREVIEW: Device has been announced but is not in production. Samples may or may not be available.

OBSOLETE: TI has discontinued the production of the device.

⁽²⁾ Eco Plan - The planned eco-friendly classification: Pb-Free (RoHS), Pb-Free (RoHS Exempt), or Green (RoHS & no Sb/Br) - please check <http://www.ti.com/productcontent> for the latest availability information and additional product content details.

TBD: The Pb-Free/Green conversion plan has not been defined.

Pb-Free (RoHS): TI's terms "Lead-Free" or "Pb-Free" mean semiconductor products that are compatible with the current RoHS requirements for all 6 substances, including the requirement that lead not exceed 0.1% by weight in homogeneous materials. Where designed to be soldered at high temperatures, TI Pb-Free products are suitable for use in specified lead-free processes.

Pb-Free (RoHS Exempt): This component has a RoHS exemption for either 1) lead-based flip-chip solder bumps used between the die and package, or 2) lead-based die adhesive used between the die and leadframe. The component is otherwise considered Pb-Free (RoHS compatible) as defined above.

Green (RoHS & no Sb/Br): TI defines "Green" to mean Pb-Free (RoHS compatible), and free of Bromine (Br) and Antimony (Sb) based flame retardants (Br or Sb do not exceed 0.1% by weight in homogeneous material)

⁽³⁾ MSL, Peak Temp. -- The Moisture Sensitivity Level rating according to the JEDEC industry standard classifications, and peak solder temperature.

Important Information and Disclaimer: The information provided on this page represents TI's knowledge and belief as of the date that it is provided. TI bases its knowledge and belief on information provided by third parties, and makes no representation or warranty as to the accuracy of such information. Efforts are underway to better integrate information from third parties. TI has taken and continues to take reasonable steps to provide representative and accurate information but may not have conducted destructive testing or chemical analysis on incoming materials and chemicals. TI and TI suppliers consider certain information to be proprietary, and thus CAS numbers and other limited information may not be available for release.

In no event shall TI's liability arising out of such information exceed the total purchase price of the TI part(s) at issue in this document sold by TI to Customer on an annual basis.

TAPE AND REEL INFORMATION

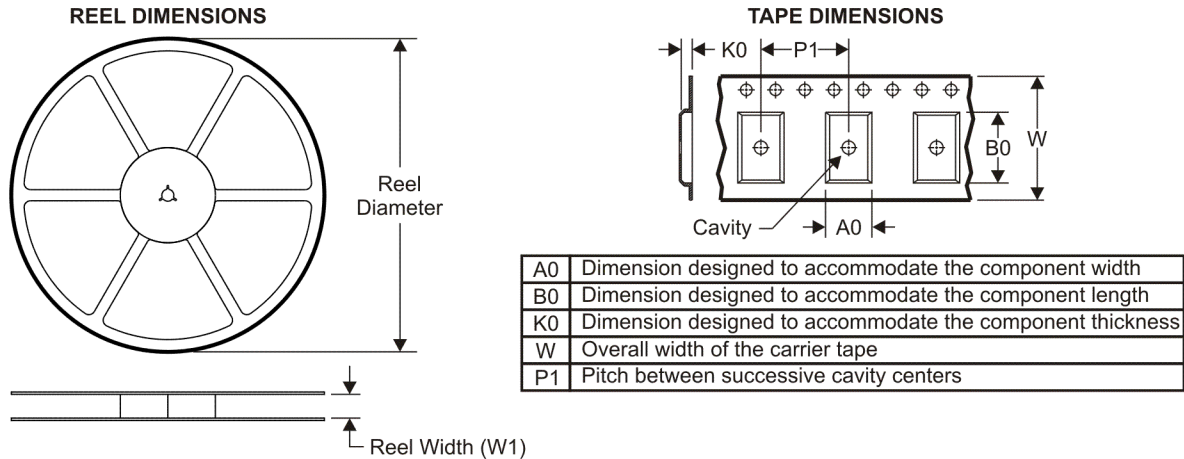

QUADRANT ASSIGNMENTS FOR PIN 1 ORIENTATION IN TAPE



*All dimensions are nominal

Device	Package Type	Package Drawing	Pins	SPQ	Reel Diameter (mm)	Reel Width W1 (mm)	A0 (mm)	B0 (mm)	K0 (mm)	P1 (mm)	W (mm)	Pin1 Quadrant
TPS65110RGER	VQFN	RGE	24	3000	330.0	12.4	4.3	4.3	1.5	8.0	12.0	Q2

TAPE AND REEL BOX DIMENSIONS



*All dimensions are nominal

Device	Package Type	Package Drawing	Pins	SPQ	Length (mm)	Width (mm)	Height (mm)
TPS65110RGER	VQFN	RGE	24	3000	340.5	333.0	20.6

RGE (S-PVQFN-N24)

PLASTIC QUAD FLATPACK NO-LEAD

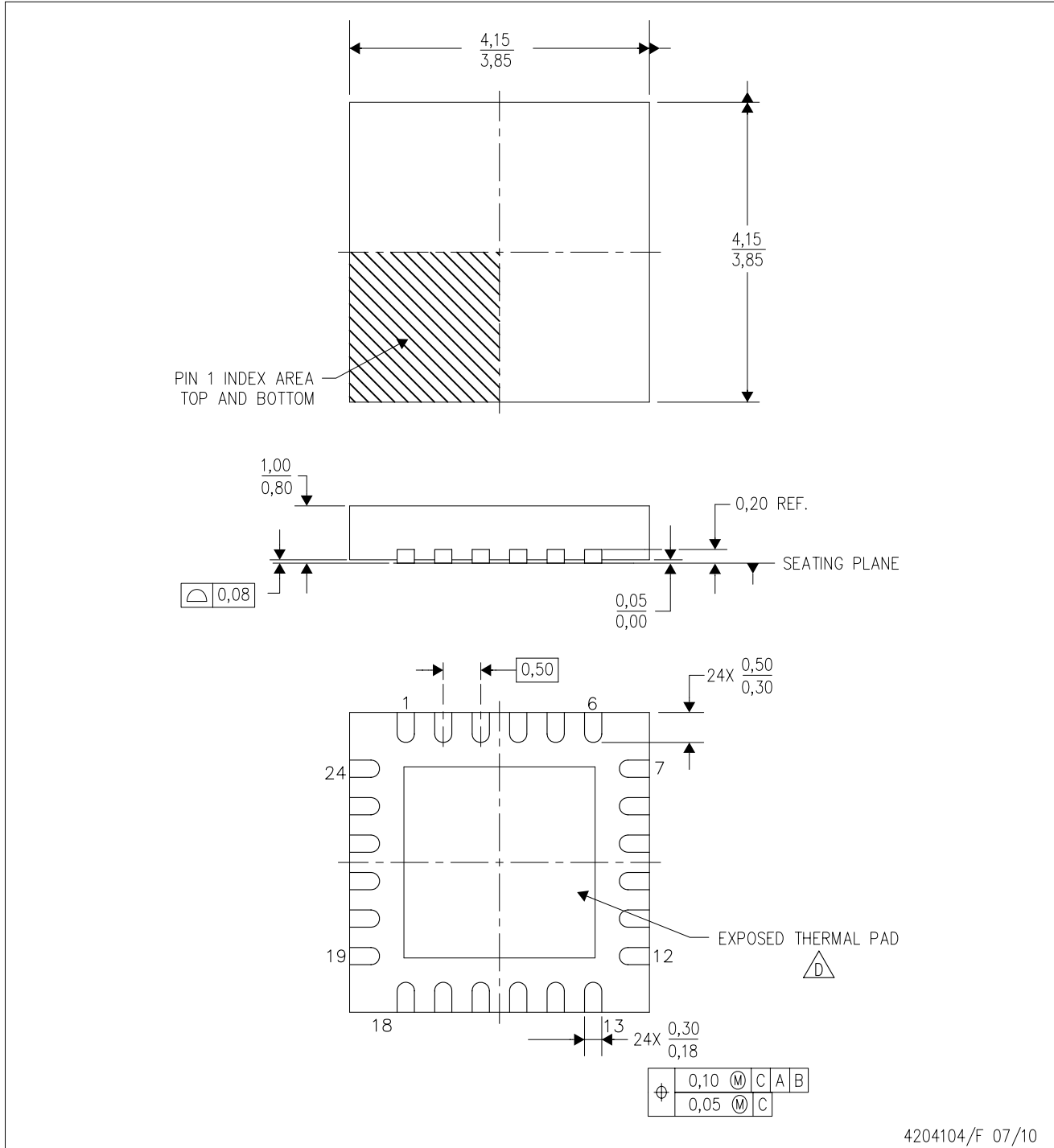

4204104/F 07/10

- NOTES:
- A. All linear dimensions are in millimeters. Dimensioning and tolerancing per ASME Y14.5M-1994.
 - B. This drawing is subject to change without notice.
 - C. Quad Flatpack, No-Leads (QFN) package configuration.
 -  The package thermal pad must be soldered to the board for thermal and mechanical performance. See the Product Data Sheet for details regarding the exposed thermal pad dimensions.
 - E. Falls within JEDEC MO-220.

THERMAL PAD MECHANICAL DATA

RGE (S-PVQFN-N24)

PLASTIC QUAD FLATPACK NO-LEAD

THERMAL INFORMATION

This package incorporates an exposed thermal pad that is designed to be attached directly to an external heatsink. The thermal pad must be soldered directly to the printed circuit board (PCB). After soldering, the PCB can be used as a heatsink. In addition, through the use of thermal vias, the thermal pad can be attached directly to the appropriate copper plane shown in the electrical schematic for the device, or alternatively, can be attached to a special heatsink structure designed into the PCB. This design optimizes the heat transfer from the integrated circuit (IC).

For information on the Quad Flatpack No-Lead (QFN) package and its advantages, refer to Application Report, QFN/SON PCB Attachment, Texas Instruments Literature No. SLUA271. This document is available at www.ti.com.

The exposed thermal pad dimensions for this package are shown in the following illustration.

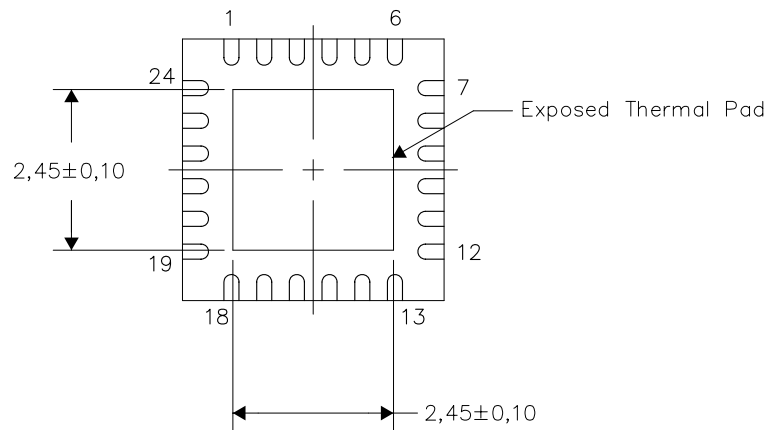

Bottom View

Exposed Thermal Pad Dimensions

NOTES:

- 1) All linear dimensions are in millimeters

RGE (S-PVQFN-N24)

PLASTIC QUAD FLATPACK NO-LEAD

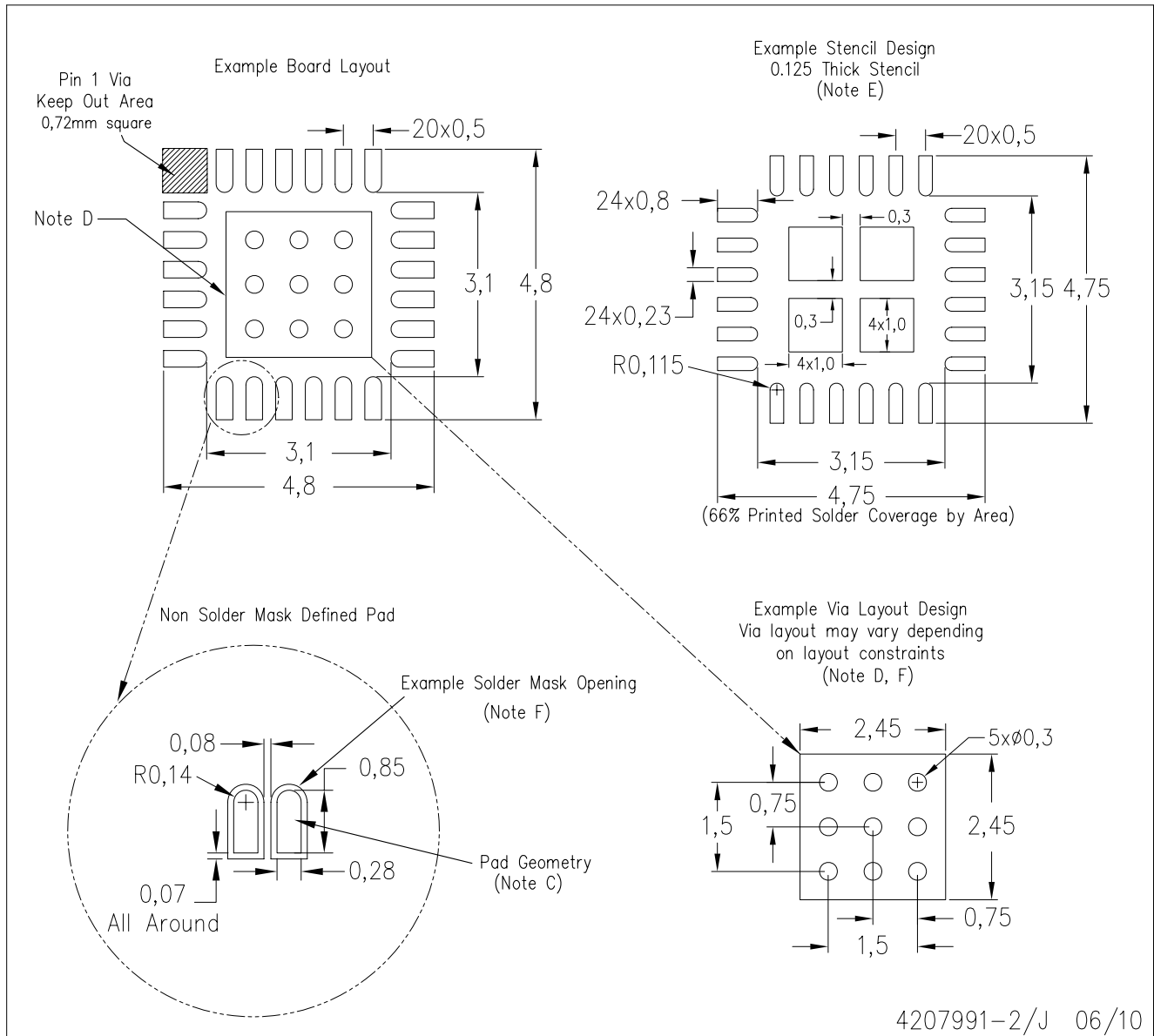

- NOTES:
- A. All linear dimensions are in millimeters.
 - B. This drawing is subject to change without notice.
 - C. Publication IPC-7351 is recommended for alternate designs.
 - D. This package is designed to be soldered to a thermal pad on the board. Refer to Application Note, Quad Flat-Pack Packages, Texas Instruments Literature No. SLUA271, and also the Product Data Sheets for specific thermal information, via requirements, and recommended board layout. These documents are available at www.ti.com <<http://www.ti.com>>.
 - E. Laser cutting apertures with trapezoidal walls and also rounding corners will offer better paste release. Customers should contact their board assembly site for stencil design recommendations. Refer to IPC 7525 for stencil design considerations.
 - F. Customers should contact their board fabrication site for recommended solder mask tolerances and via tenting recommendations for vias placed in the thermal pad.

IMPORTANT NOTICE

Texas Instruments Incorporated and its subsidiaries (TI) reserve the right to make corrections, modifications, enhancements, improvements, and other changes to its products and services at any time and to discontinue any product or service without notice. Customers should obtain the latest relevant information before placing orders and should verify that such information is current and complete. All products are sold subject to TI's terms and conditions of sale supplied at the time of order acknowledgment.

TI warrants performance of its hardware products to the specifications applicable at the time of sale in accordance with TI's standard warranty. Testing and other quality control techniques are used to the extent TI deems necessary to support this warranty. Except where mandated by government requirements, testing of all parameters of each product is not necessarily performed.

TI assumes no liability for applications assistance or customer product design. Customers are responsible for their products and applications using TI components. To minimize the risks associated with customer products and applications, customers should provide adequate design and operating safeguards.

TI does not warrant or represent that any license, either express or implied, is granted under any TI patent right, copyright, mask work right, or other TI intellectual property right relating to any combination, machine, or process in which TI products or services are used. Information published by TI regarding third-party products or services does not constitute a license from TI to use such products or services or a warranty or endorsement thereof. Use of such information may require a license from a third party under the patents or other intellectual property of the third party, or a license from TI under the patents or other intellectual property of TI.

Reproduction of TI information in TI data books or data sheets is permissible only if reproduction is without alteration and is accompanied by all associated warranties, conditions, limitations, and notices. Reproduction of this information with alteration is an unfair and deceptive business practice. TI is not responsible or liable for such altered documentation. Information of third parties may be subject to additional restrictions.

Resale of TI products or services with statements different from or beyond the parameters stated by TI for that product or service voids all express and any implied warranties for the associated TI product or service and is an unfair and deceptive business practice. TI is not responsible or liable for any such statements.

TI products are not authorized for use in safety-critical applications (such as life support) where a failure of the TI product would reasonably be expected to cause severe personal injury or death, unless officers of the parties have executed an agreement specifically governing such use. Buyers represent that they have all necessary expertise in the safety and regulatory ramifications of their applications, and acknowledge and agree that they are solely responsible for all legal, regulatory and safety-related requirements concerning their products and any use of TI products in such safety-critical applications, notwithstanding any applications-related information or support that may be provided by TI. Further, Buyers must fully indemnify TI and its representatives against any damages arising out of the use of TI products in such safety-critical applications.

TI products are neither designed nor intended for use in military/aerospace applications or environments unless the TI products are specifically designated by TI as military-grade or "enhanced plastic." Only products designated by TI as military-grade meet military specifications. Buyers acknowledge and agree that any such use of TI products which TI has not designated as military-grade is solely at the Buyer's risk, and that they are solely responsible for compliance with all legal and regulatory requirements in connection with such use.

TI products are neither designed nor intended for use in automotive applications or environments unless the specific TI products are designated by TI as compliant with ISO/TS 16949 requirements. Buyers acknowledge and agree that, if they use any non-designated products in automotive applications, TI will not be responsible for any failure to meet such requirements.

Following are URLs where you can obtain information on other Texas Instruments products and application solutions:

Products		Applications	
Amplifiers	amplifier.ti.com	Audio	www.ti.com/audio
Data Converters	dataconverter.ti.com	Automotive	www.ti.com/automotive
DLP® Products	www.dlp.com	Communications and Telecom	www.ti.com/communications
DSP	dsp.ti.com	Computers and Peripherals	www.ti.com/computers
Clocks and Timers	www.ti.com/clocks	Consumer Electronics	www.ti.com/consumer-apps
Interface	interface.ti.com	Energy	www.ti.com/energy
Logic	logic.ti.com	Industrial	www.ti.com/industrial
Power Mgmt	power.ti.com	Medical	www.ti.com/medical
Microcontrollers	microcontroller.ti.com	Security	www.ti.com/security
RFID	www.ti-rfid.com	Space, Avionics & Defense	www.ti.com/space-avionics-defense
RF/IF and ZigBee® Solutions	www.ti.com/lprf	Video and Imaging	www.ti.com/video
		Wireless	www.ti.com/wireless-apps

Mailing Address: Texas Instruments, Post Office Box 655303, Dallas, Texas 75265
Copyright © 2010, Texas Instruments Incorporated

Looking for pricing, stock, or lifecycle information?

Click below to explore more details on WIN SOURCE:

 [View TPS65111RGER](#) on WIN SOURCE

 [Texas Instruments](#) Information

Optimize Your Supply Chain with WIN SOURCE Solutions

-  Global Sourcing Solution
-  Obsolete Management
-  Cost Control Management
-  Shortage Management
-  Alternative Solution
-  Excess Inventory Management