





# LVDS or LVTTTL/LVCMOS Input to 14 LVTTTL/LVCMOS Output Clock Driver

MAX9160

## General Description

The MAX9160 125MHz, 14-port LVTTTL/LVCMOS clock driver repeats the selected LVDS or LVTTTL/LVCMOS input on two output banks. Each bank consists of seven LVTTTL/LVCMOS series terminated outputs and a bank enable. The LVDS input has a fail-safe function. The MAX9160 has a propagation delay that can be adjusted using an external resistor to set the bias current for an internal delay cell. The LVTTTL/LVCMOS outputs feature 200ps maximum output-to-output skew and  $\pm 100$ ps maximum added peak-to-peak jitter.

The MAX9160 is designed to operate with a 3.3V supply voltage over the extended temperature range of  $-40^{\circ}\text{C}$  to  $+85^{\circ}\text{C}$ . This device is available in 28-pin exposed- and nonexposed-pad TSSOP and 32-lead 5mm x 5mm QFN packages.

## Applications

Cellular Base Stations	Digital Cross-Connects
Servers	DSLAMs
Add/Drop Multiplexers	Networking Equipment

Typical Application Circuit and Functional Diagram appear at end of data sheet.

## Pin Configurations

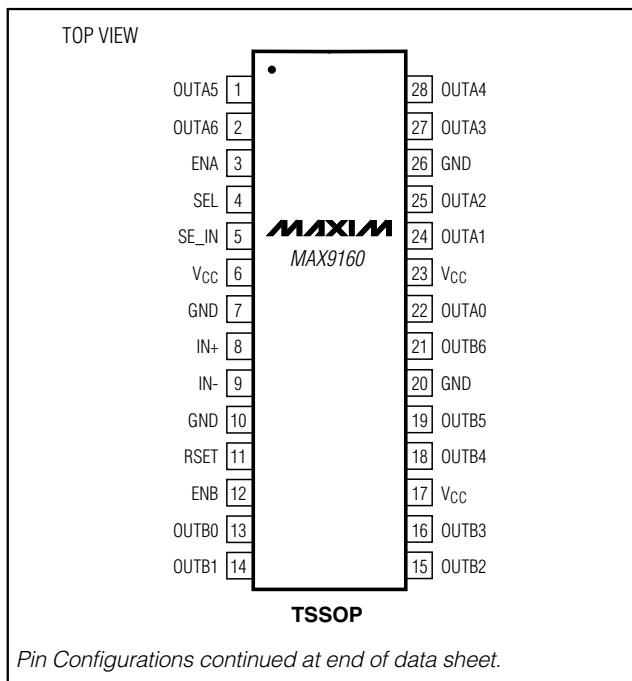

## Features

- ◆ LVDS or LVTTTL/LVCMOS Input Selection
- ◆ LVDS Input Fail-Safe Sets Outputs High for Open, Undriven Short, or Undriven Parallel Termination
- ◆ Two Output Banks with Separate Bank Enables
- ◆ Integrated Output Series Termination for 60 $\Omega$  Lines
- ◆ 200ps (max) Output-to-Output Skew
- ◆  $\pm 100$ ps (max) Peak-to-Peak Added Output Jitter
- ◆ 42% to 58% Output Duty Cycle at 125MHz
- ◆ Guaranteed 125MHz Operating Frequency
- ◆ LVDS Input Is High Impedance with  $V_{CC} = 0V$  or Open (Hot Swappable)
- ◆ 28-Pin Exposed- and Nonexposed-Pad TSSOP or 32-Lead QFN Packages
- ◆  $-40^{\circ}\text{C}$  to  $+85^{\circ}\text{C}$  Operating Temperature
- ◆ 3.0V to 3.6V Supply Voltage

## Ordering Information

PART	TEMP RANGE	PIN-PACKAGE
MAX9160EUI	$-40^{\circ}\text{C}$ to $+85^{\circ}\text{C}$	28 TSSOP
MAX9160AEUI	$-40^{\circ}\text{C}$ to $+85^{\circ}\text{C}$	28 TSSOP-EP**
MAX9160EGJ*	$-40^{\circ}\text{C}$ to $+85^{\circ}\text{C}$	32 QFN-EP

\*Future product—contact factory for availability.

\*\*Exposed pad.

## Function Table

EN_	SEL	SE_IN	$V_{ID}$	OUT_
H	H	H	X	H
H	H	L or open	X	L
H	L or open	X	$\geq +50\text{mV}$	H
H	L or open	X	$\leq -50\text{mV}$	L
H	L or open	X	Open, undriven short, or undriven parallel termination	H
L or Open	X	X	X	L

$V_{ID} = V_{IN+} - V_{IN-}$

H = high logic level

L = low logic level

X = don't care



# LVDS or LVTTL/LVCMOS Input to 14 LVTTL/LVCMOS Output Clock Driver

## ABSOLUTE MAXIMUM RATINGS

V <sub>CC</sub> to GND .....	-0.3V to +4V	Storage Temperature Range .....	-65°C to +150°C
IN+, IN- to GND .....	-0.3V to +4V	Junction Temperature .....	+150°C
SE_IN, EN_, SEL, RSET, OUT_ to GND .....	-0.3V to V <sub>CC</sub> + 0.3V	Operating Temperature Range .....	-40°C to +85°C
Output Short-Circuit Duration (OUT_) (Note 1) .....	Continuous	ESD Protection	
Continuous Power Dissipation (T <sub>A</sub> = +70°C)		Human Body Model (IN+, IN-) .....	±16kV
28-Pin TSSOP (derate 12.8mW/°C above +70°C) .....	1024mW	Human Body Model (SE_IN) .....	±8kV
28-Pin TSSOP-EP (derate 23.8mW/°C above +70°C) .....	1904mW	Soldering Temperature (10s) .....	+300°C
32-Pin QFN (derate 21.2mW/°C above +70°C) .....	1704mW		

**Note 1:** Short one output at a time. Do not exceed the absolute maximum junction temperature.

Stresses beyond those listed under "Absolute Maximum Ratings" may cause permanent damage to the device. These are stress ratings only, and functional operation of the device at these or any other conditions beyond those indicated in the operational sections of the specifications is not implied. Exposure to absolute maximum rating conditions for extended periods may affect device reliability.

## DC ELECTRICAL CHARACTERISTICS

(V<sub>CC</sub> = 3.0V to 3.6V, ENA = ENB = high, RSET = 12kΩ ±1%, differential input voltage |V<sub>ID</sub>| = 0.05V to 1.2V, input common-mode voltage V<sub>CM</sub> = |V<sub>ID</sub>|/2 to 2.4V - |V<sub>ID</sub>|/2, T<sub>A</sub> = -40°C to +85°C, unless otherwise noted. Typical values are at V<sub>CC</sub> = 3.3V, |V<sub>ID</sub>| = 0.2V, V<sub>CM</sub> = 1.2V, T<sub>A</sub> = +25°C.) (Notes 2, 3)

PARAMETER	SYMBOL	CONDITIONS	MIN	TYP	MAX	UNITS
<b>SINGLE-ENDED INPUTS (SE_IN, ENA, ENB, SEL)</b>						
Input High Voltage	V <sub>IH</sub>		2.0		V <sub>CC</sub>	V
Input Low Voltage	V <sub>IL</sub>		GND		0.8	V
Input Clamp Voltage	V <sub>CL</sub>	I <sub>CL</sub> = -18mA	-1.5	-0.85		V
Input Current	I <sub>IN</sub>	V <sub>IN</sub> = high or low	-20		+20	μA
SE_IN Capacitance (Note 4)	C <sub>IN</sub>	SE_IN to GND			6.1	pF
<b>LVDS INPUT (IN+, IN-)</b>						
Differential Input High Threshold	V <sub>TH</sub>				50	mV
Differential Input Low Threshold	V <sub>TL</sub>		-50			mV
Input Current	I <sub>IN+</sub> , I <sub>IN-</sub>	0.05V ≤  V <sub>ID</sub>   ≤ 0.6V	-15		+15	μA
		0.6V <  V <sub>ID</sub>   ≤ 1.2V	-20		+20	
Power-Off Input Current	I <sub>IN+(off)</sub> I <sub>IN-(off)</sub>	0.05V ≤  V <sub>ID</sub>   ≤ 0.6V, V <sub>CC</sub> = 0V or open	-15		+15	μA
		0.6V <  V <sub>ID</sub>   ≤ 1.2V, V <sub>CC</sub> = 0V or open	-20		+20	
Input Resistor 1	R <sub>IN1</sub>	V <sub>CC</sub> = 3.6V or 0V, Figure 1	51		100	kΩ
Input Resistor 2	R <sub>IN2</sub>	V <sub>CC</sub> = 3.6V or 0 V, Figure 1	200		341	kΩ
Input Capacitance (Note 4)	C <sub>IN</sub>	IN+ or IN- to GND			6.0	pF
<b>OUTPUTS (OUT_)</b>						
Output Short-Circuit Current (Note 1)	I <sub>OS</sub>	SEL = high, SE_IN = high, V <sub>OUT</sub> = 0V	-115		-30	mA
		SEL = low, V <sub>ID</sub> = 100mV, V <sub>OUT</sub> = 0V				
Output Capacitance (Note 4)	C <sub>O</sub>	OUT_ to GND			9	pF
Output High Voltage	V <sub>OH</sub>	I <sub>OH</sub> = -100μA	V <sub>CC</sub> - 0.2		V	
		I <sub>OH</sub> = -4mA	2.4			
		I <sub>OH</sub> = -8mA	2.1			
Fail-Safe Output High Voltage	V <sub>OHFS</sub>	SEL = low, inputs open, undriven short, or undriven parallel terminated	I <sub>OH</sub> = -100μA	V <sub>CC</sub> - 0.2		V
			I <sub>OH</sub> = -4mA	2.4		
			I <sub>OH</sub> = -8mA	2.1		

# LVDS or LVTTTL/LVCMOS Input to 14 LVTTTL/LVCMOS Output Clock Driver

MAX9160

## DC ELECTRICAL CHARACTERISTICS (continued)

( $V_{CC} = 3.0V$  to  $3.6V$ ,  $ENA = ENB = \text{high}$ ,  $RSET = 12k\Omega \pm 1\%$ , differential input voltage  $|V_{ID}| = 0.05V$  to  $1.2V$ , input common-mode voltage  $V_{CM} = |V_{ID}|/2$  to  $2.4V - |V_{ID}|/2$ ,  $T_A = -40^\circ C$  to  $+85^\circ C$ , unless otherwise noted. Typical values are at  $V_{CC} = 3.3V$ ,  $|V_{ID}| = 0.2V$ ,  $V_{CM} = 1.2V$ ,  $T_A = +25^\circ C$ .) (Notes 2, 3)

PARAMETER	SYMBOL	CONDITIONS	MIN	TYP	MAX	UNITS
Output Low Voltage	$V_{OL}$	$I_{OL} = 100\mu A$			0.2	V
		$I_{OL} = 4mA$			0.4	
		$I_{OL} = 8mA$			0.8	
Supply Current	$I_{CC}$	SEL = high, SE_IN = high or low, no load			15	$\mu A$
		SEL = low, $V_{ID} = -100mV$ or $100mV$ , no load		7.0	10	mA
Output Series Resistance (Note 5)	$R_S$	Output switched high, $V_{OUT} = 1.65V$		72		$\Omega$
		Output switched low, $V_{OUT} = 1.65V$		61		

## AC ELECTRICAL CHARACTERISTICS

( $V_{CC} = 3.0V$  to  $3.6V$ ,  $C_L = 20pF$ ,  $ENA = ENB = \text{high}$ , SEL = high or low,  $RSET = 12k\Omega \pm 1\%$ , differential input voltage  $|V_{ID}| = 0.15V$  to  $1.2V$ , input common-mode voltage  $V_{CM} = |V_{ID}|/2$  to  $2.4V - |V_{ID}|/2$ ,  $T_A = -40^\circ C$  to  $+85^\circ C$ , unless otherwise noted. Typical values are at  $V_{CC} = 3.3V$ ,  $|V_{ID}| = 0.2V$ ,  $V_{CM} = 1.2V$ ,  $T_A = +25^\circ C$ .) (Notes 6, 7, 8)

PARAMETER	SYMBOL	CONDITIONS	MIN	TYP	MAX	UNITS	
Rise Time	$t_R$	Figures 2 and 3	1.4		2.95	ns	
Fall Time	$t_F$		1.4		2.95	ns	
Low-to-High Propagation Delay IN+, IN- to OUT_	$t_{PLH1}$	SEL = low	RSET = $12k\Omega$	5.3	6.5	8.0	ns
			RSET = open	4.9		9.0	
High-to-Low Propagation Delay IN+, IN- to OUT_	$t_{PHL1}$	SEL = low	RSET = $12k\Omega$	5.3	6.4	8.0	ns
			RSET = open	4.9		9.0	
Low-to-High Propagation Delay SE_IN to OUT_	$t_{PLH2}$	SEL = high	2.2	2.9	3.8	ns	
High-to-Low Propagation Delay SE_IN to OUT_	$t_{PHL2}$	SEL = high	2.2	3.1	3.8	ns	
Added Peak-to-Peak Output Jitter	$t_J$	100mV peak-to-peak supply noise at 200kHz, 3.3V supply			100	ps	
Output Duty Cycle	ODC	$f_{IN} = 125MHz$	42		58	%	
		$f_{IN} = 35MHz$	48.75		51.25		
Output-to-Output Skew (Note 9)	$t_{SKOO}$			200		ps	
Part-to-Part Skew (Note 10)	$t_{SKPP1}$	SE_IN to OUT_, SEL = high			0.9	ns	
		IN+, IN- to OUT_, SEL = low			2.2		
Part-to-Part Skew (Note 11)	$t_{SKPP2}$	SE_IN to OUT_, SEL = high			1.6	ns	
		IN+, IN- to OUT_, SEL = low			2.7		
Maximum Switching Frequency (Note 12)	$f_{MAX}$		125			MHz	

**Note 2:** Current into a pin is defined as positive. Current out of a pin is defined as negative. All voltages are referenced to ground except  $V_{TH}$ ,  $V_{TL}$ , and  $V_{ID}$ .

**Note 3:** Parameter limits over temperature are guaranteed by design and characterization. Devices are production tested at  $T_A = +25^\circ C$ .

# LVDS or LVTTTL/LVCMOS Input to 14 LVTTTL/LVCMOS Output Clock Driver

## AC ELECTRICAL CHARACTERISTICS (continued)

( $V_{CC} = 3.0V$  to  $3.6V$ ,  $C_L = 20pF$ ,  $ENA = ENB = \text{high}$ ,  $SEL = \text{high or low}$ ,  $RSET = 12k\Omega \pm 1\%$ , differential input voltage  $|V_{ID}| = 0.15V$  to  $1.2V$ , input common-mode voltage  $V_{CM} = |V_{ID}|/2$  to  $2.4V - |V_{ID}|/2$ ,  $T_A = -40^\circ C$  to  $+85^\circ C$ , unless otherwise noted. Typical values are at  $V_{CC} = 3.3V$ ,  $|V_{ID}| = 0.2V$ ,  $V_{CM} = 1.2V$ ,  $T_A = +25^\circ C$ .) (Notes 6, 7, 8)

**Note 4:** Guaranteed by design and characterization.

**Note 5:** Total of driver output resistance and integrated series resistor.

**Note 6:** AC parameters are guaranteed by design and characterization and are not production tested. Limits are set at  $\pm 6$  sigma.

**Note 7:**  $C_L$  includes scope probe and test jig capacitance.

**Note 8:** Pulse generator conditions for SE\_IN input: frequency = 125MHz, 50% duty cycle,  $Z_O = 50\Omega$ ,  $t_R = 1.2ns$ , and  $t_F = 1.2ns$  (20% to 80%),  $V_{OH} = V_{CC}$ ,  $V_{OL} = 0V$ . Pulse generator conditions for IN+, IN- input: frequency = 125MHz, 50% duty cycle,  $Z_O = 50\Omega$ ,  $t_R = 1ns$ , and  $t_F = 1ns$  (20% to 80%).  $V_{ID}$ ,  $V_{CM}$  as specified in *AC Electrical Characteristics* general conditions.

**Note 9:** Measured between outputs with identical loads at  $V_{CC}/2$  for a same-edge transition.

**Note 10:**  $t_{SKPP1}$  is the greatest difference in propagation delay between different parts operating under identical conditions within rated conditions.

**Note 11:**  $t_{SKPP2}$  is the greatest difference in propagation delay between different parts operating within rated conditions.

**Note 12:** All AC specifications met at  $f_{MAX}$ .

## Typical Operating Characteristics

(MAX9160 with  $RSET = 12k\Omega \pm 1\%$ ,  $V_{CC} = 3.3V$ ,  $C_L = 20pF$ ,  $ENA = ENB = \text{high}$ ,  $|V_{ID}| = 0.2$ ,  $V_{CM} = 1.2V$ ,  $f_{IN} = 125MHz$ ,  $T_A = +25^\circ C$ , unless otherwise noted.)

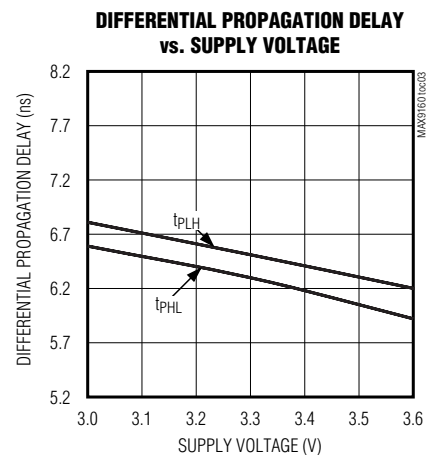
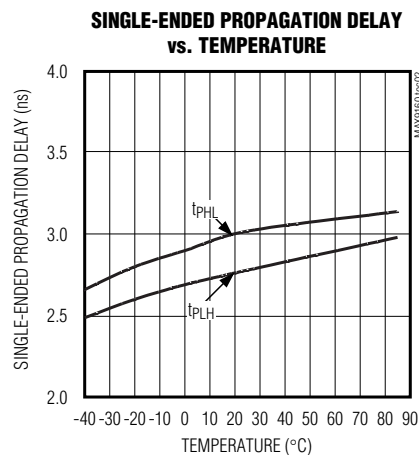
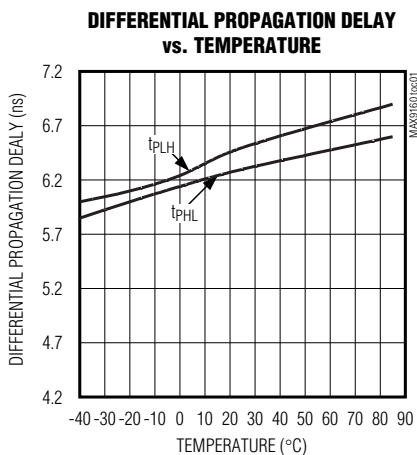

# LVDS or LVTTTL/LVCMOS Input to 14 LVTTTL/LVCMOS Output Clock Driver

MAX9160

## Typical Operating Characteristics (continued)

(MAX9160 with RSET = 12kΩ ±1%, V<sub>CC</sub> = 3.3V, C<sub>L</sub> = 20pF, ENA = ENB = high, I<sub>VDD</sub> = 0.2, V<sub>CM</sub> = 1.2V, f<sub>IN</sub> = 125MHz, T<sub>A</sub> = +25°C, unless otherwise noted.)

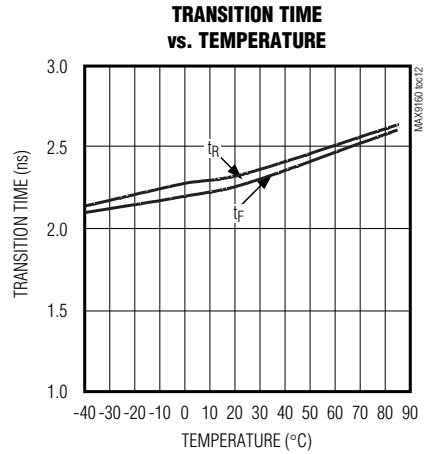
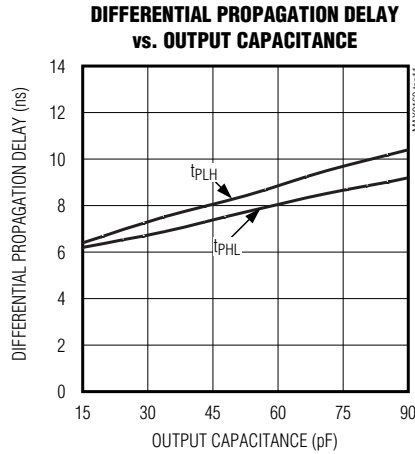
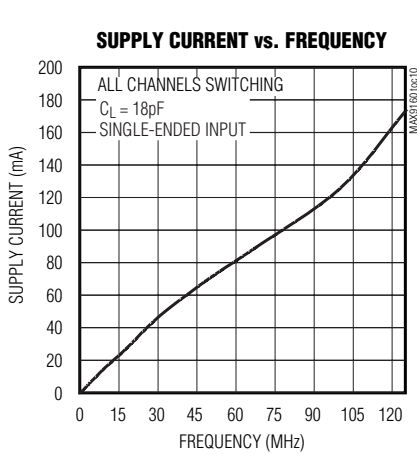
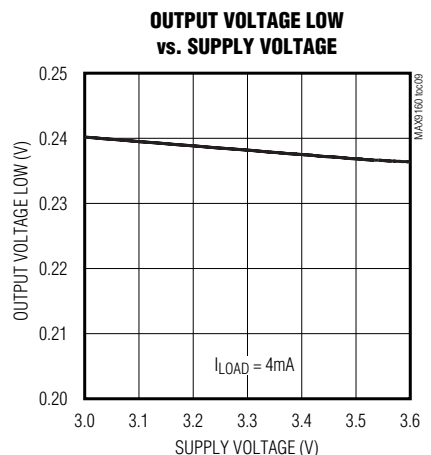
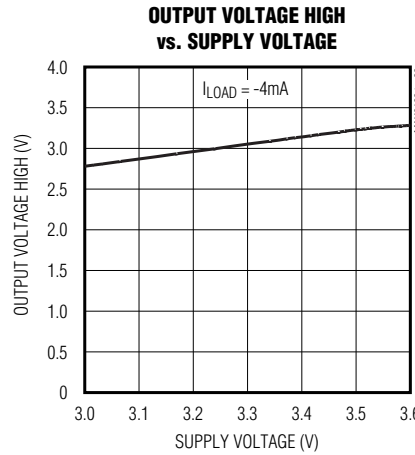
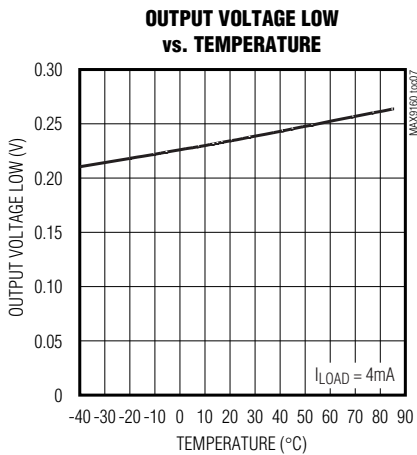
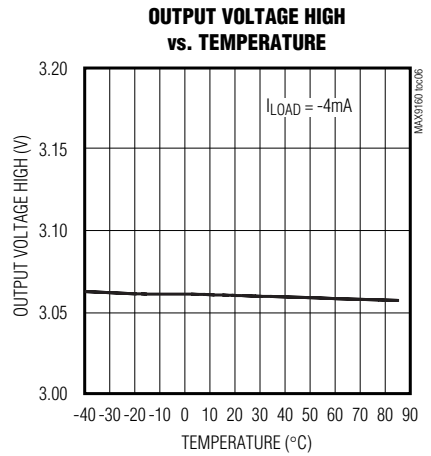
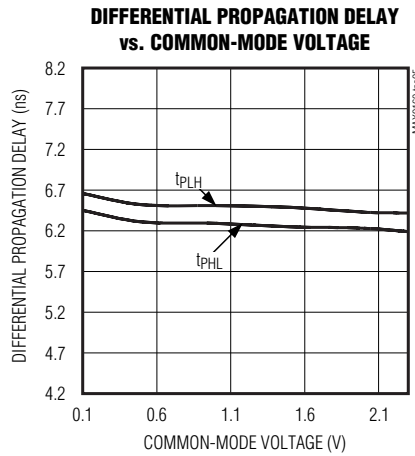
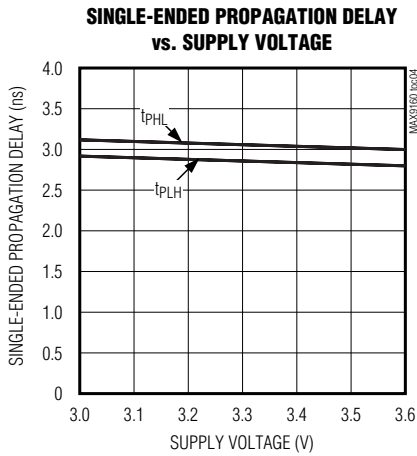

# LVDS or LVTTTL/LVCMOS Input to 14 LVTTTL/LVCMOS Output Clock Driver

## Typical Operating Characteristics (continued)

(MAX9160 with RSET = 12kΩ ±1%, V<sub>CC</sub> = 3.3V, C<sub>L</sub> = 20pF, ENA = ENB = high, |V<sub>ID</sub>| = 0.2, V<sub>CM</sub> = 1.2V, f<sub>IN</sub> = 125MHz, T<sub>A</sub> = +25°C, unless otherwise noted.)

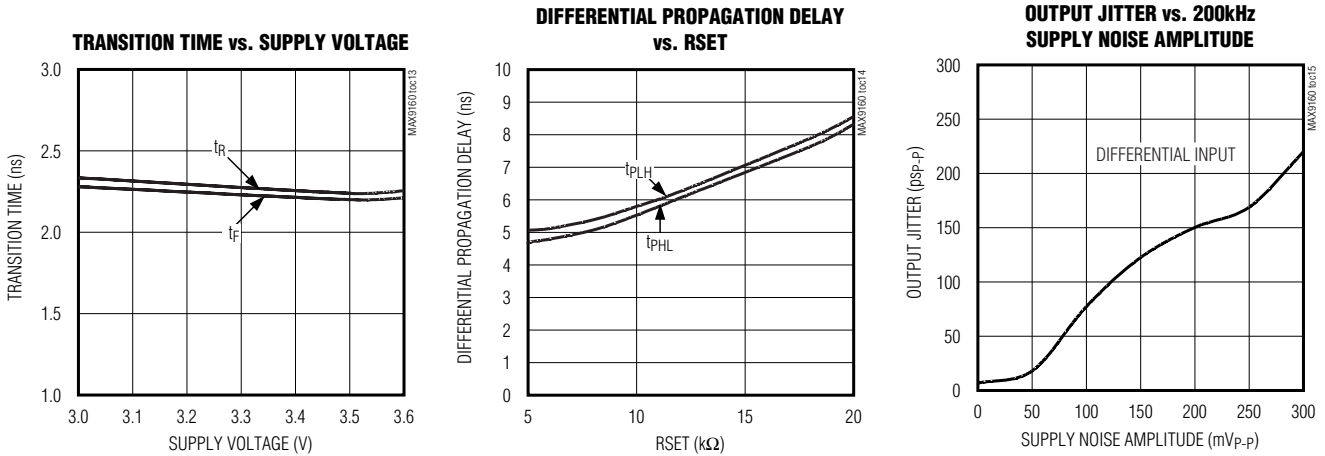

## Pin Description

PIN		NAME	FUNCTION
QFN	TSSOP		
1	4	SEL	LVCMOS/LVTTTL Level Logic Input. SEL = high selects SE_IN. SEL = low or open selects IN+, IN-. SEL is pulled to GND by an internal resistor.
2	5	SE_IN	LVCMOS/LVTTTL Level Input. SE_IN is pulled to GND by an internal resistor.
3, 12, 16, 22, 29	6, 17, 23	V <sub>CC</sub>	Positive Supply Voltage. Bypass with 0.1μF and 0.001μF capacitors to ground.
4, 7, 13, 19, 25, 28	7, 10, 20, 26	GND	Ground
5	8	IN+	Noninverting Input of Differential Input
6	9	IN-	Inverting Input of Differential Input
8	11	RSET	Connect a 12kΩ ±1% resistor to ground to decrease the minimum to maximum IN+, IN- to OUT_ propagation delay.
9	12	ENB	LVCMOS/LVTTTL Level Logic Input. When ENB = high, outputs OUTB_ are enabled and follow the selected input. When ENB = low or open, outputs OUTB_ are driven low. ENB is pulled to GND by an internal resistor.
10, 11, 14, 15, 17, 18, 20	13–16, 18, 19, 21	OUTB_	Bank B LVCMOS/LVTTTL Outputs

# LVDS or LVTTTL/LVCMOS Input to 14 LVTTTL/LVCMOS Output Clock Driver

MAX9160

## Pin Description (continued)

PIN		NAME	FUNCTION
QFN	TSSOP		
21, 23, 24, 26, 27, 30, 31	1, 2, 22, 24, 25, 27, 28	OUTA_	Bank A LVCMOS/LVTTTL Outputs
32	3	ENA	LVCMOS/LVTTTL Level Logic Input. When ENA = high, outputs OUTA_ are enabled and follow the selected input. When ENA = low or open, outputs OUTA_ are driven low. ENA is pulled to GND by an internal resistor.
EP*		Exposed Pad	Solder to PC board

\*MAX9160EGJ and MAX9160AEUI.

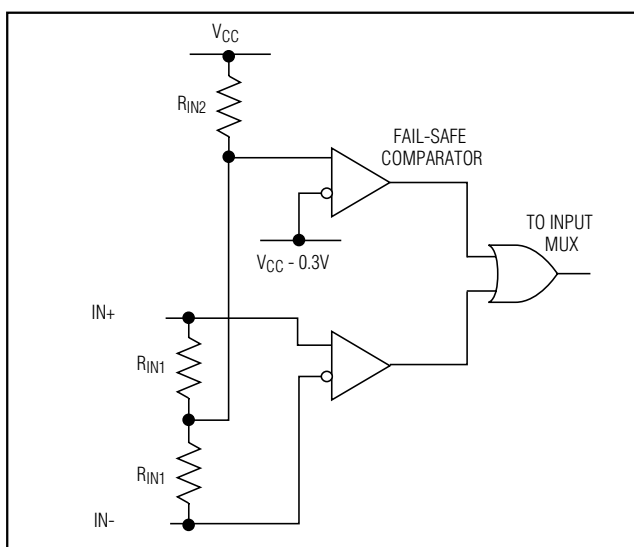

Figure 1. Fail-Safe Input Circuit

## Detailed Description

The MAX9160 125MHz, 14-port LVTTTL/LVCMOS clock driver repeats the selected LVDS or LVTTTL/LVCMOS input on two output banks. Each bank consists of seven LVTTTL/LVCMOS series terminated outputs and a bank enable. The LVDS input has a fail-safe function. The MAX9160 has a propagation delay that can be adjusted using an external resistor to set the bias current for an internal delay cell. The LVTTTL/LVCMOS outputs feature 200ps maximum output-to-output skew and  $\pm 100$ ps maximum added peak-to-peak jitter.

The MAX9160 is designed to operate with a 3.3V supply voltage over the extended temperature range of

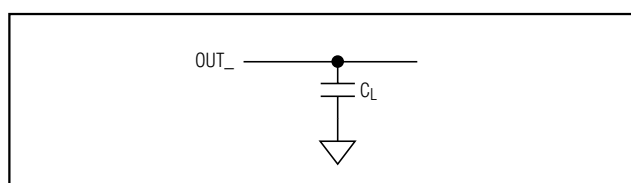

Figure 2. Output Load

-40°C to +85°C. This device is available in 28-pin exposed and nonexposed pad TSSOP and 32-lead 5mm x 5mm QFN packages.

### Fail-Safe

A fail-safe circuit on the MAX9160 sets enabled outputs high when the LVDS input is:

- Open
- Undriven and shorted
- Undriven and terminated

Without a fail-safe circuit, when the LVDS input is selected and undriven, noise may cause the enabled outputs to switch. Open or undriven terminated input conditions can occur when a cable is disconnected or cut, or when a driver output is in high impedance. A shorted input can occur because of a cable failure.

When the MAX9160 LVDS input is driven with a differential signal with a common-mode voltage between  $|V_{ID}/2|$  and  $2.4V - |V_{ID}/2|$ , the fail-safe circuit is not activated. If the input is open, undriven and shorted, or undriven and parallel terminated, an internal resistor in the fail-safe circuit pulls both of the LVDS inputs above  $V_{CC} - 0.3V$ , activating the fail-safe circuit and forcing the output high (Figure 1).

# LVDS or LVTTL/LVCMOS Input to 14 LVTTL/LVCMOS Output Clock Driver

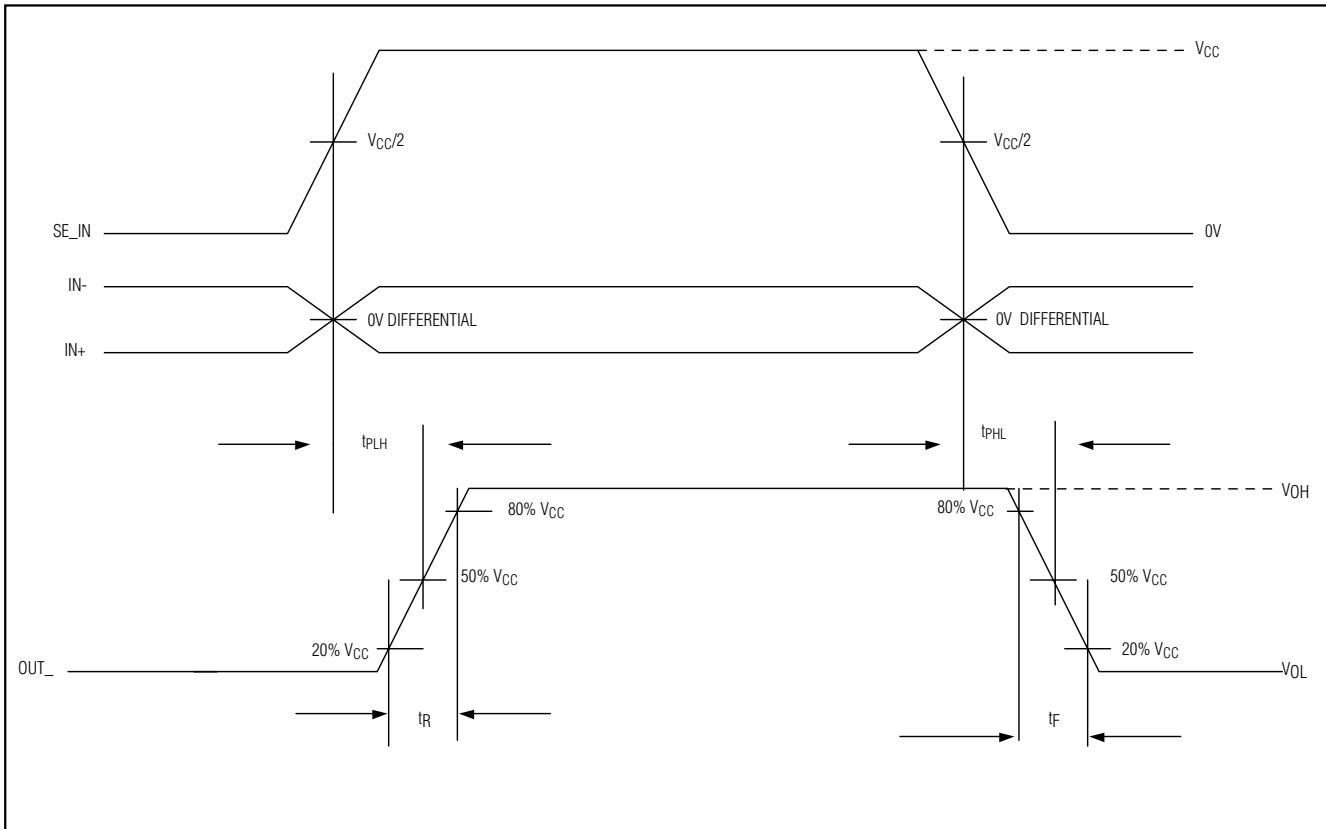

Figure 3. Transition Time and Propagation Delay Timing Diagram

### Propagation Delay and RSET

The MAX9160 delay can be adjusted by connecting a resistor from RSET to ground. See *Typical Operating Characteristics* for a graph of delay vs. RSET.

### Output Enables

Each bank of seven LVTTL/LVCMOS drivers is controlled by an output enable. Outputs follow the selected input when EN<sub>1</sub> is high. Outputs are low (not high impedance) when EN<sub>1</sub> = low.

### Power Dissipation and Package Type

Power dissipation at high switching frequencies may exceed the power dissipation capacity of the standard TSSOP package (see the Supply Current vs. Frequency graph in the *Typical Operating Characteristics*). An EP version of the TSSOP package is available that dissipates higher power. Also, a space-saving QFN package with EP is available. The EP must be soldered to the PC board.

### Supply Bypassing

Bypass each supply pin with high-frequency surface-mount ceramic 0.1μF and 0.001μF capacitors in parallel as close to the device as possible, with the smaller value capacitor closest to the device.

### Board Layout

A four-layer PC board that provides separate power, ground, input, and output signals is recommended. Keep input and output signals separated to prevent coupling.

### Chip Information

TRANSISTOR COUNT: 756

PROCESS: CMOS

# LVDS or LVTTTL/LVCMOS Input to 14 LVTTTL/LVCMOS Output Clock Driver

## Functional Diagram

MAX9160

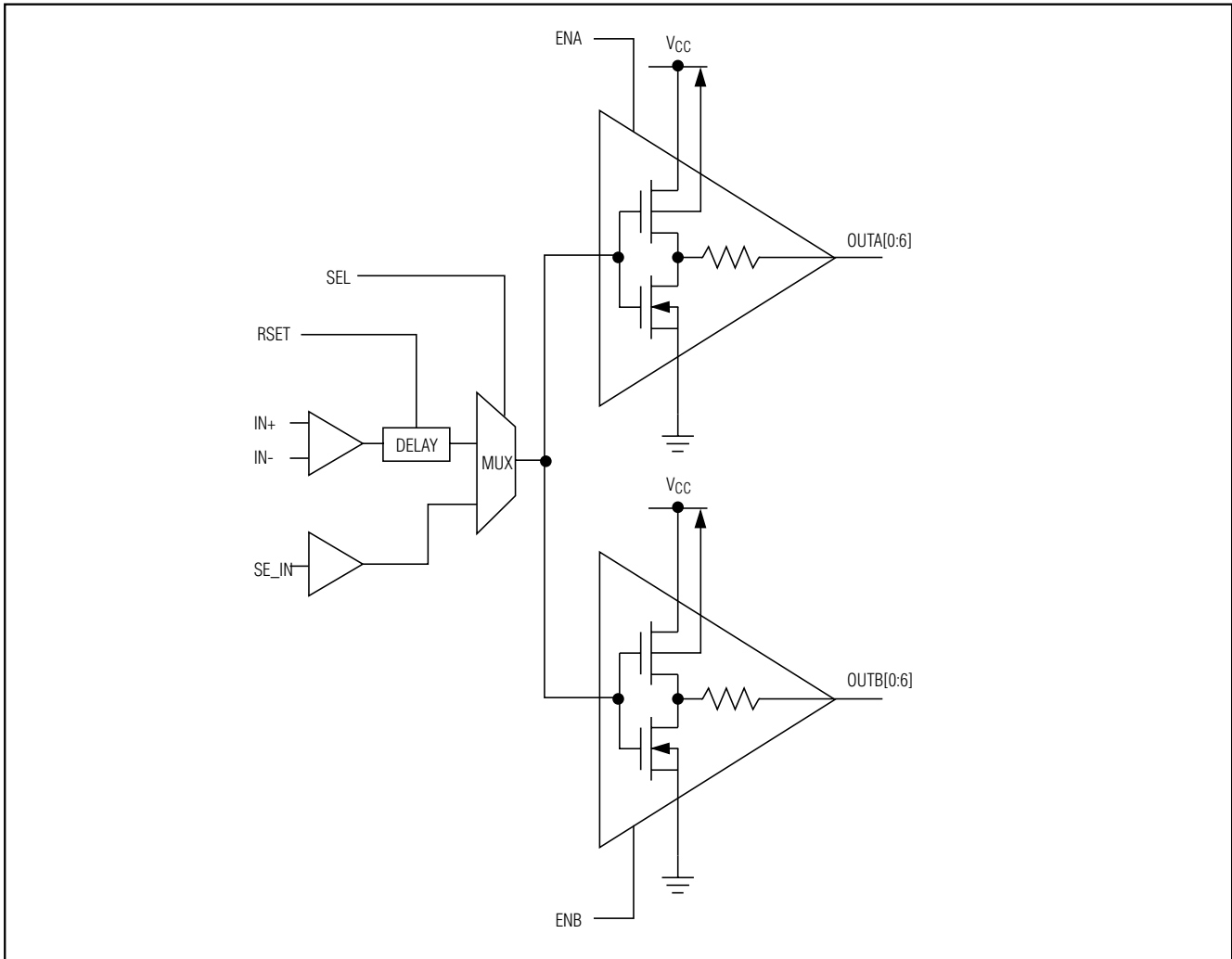

# LVDS or LVTTTL/LVCMOS Input to 14 LVTTTL/LVCMOS Output Clock Driver

## Typical Application Circuit

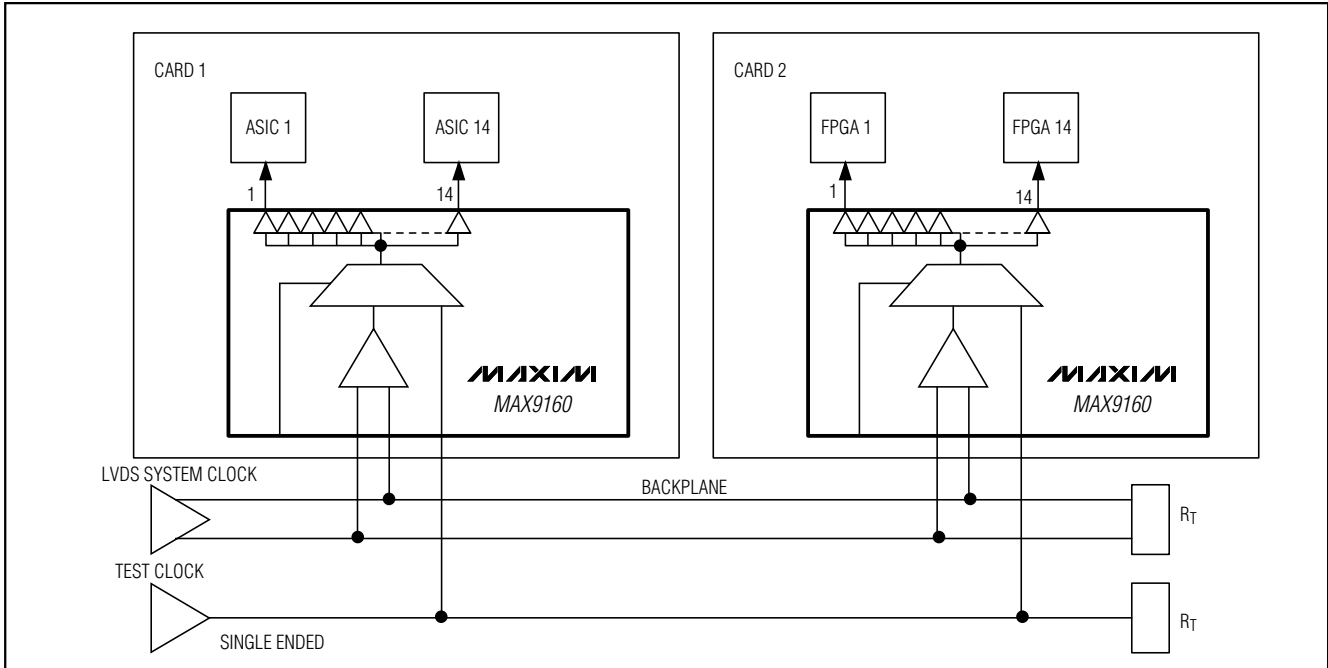

## Pin Configurations (continued)

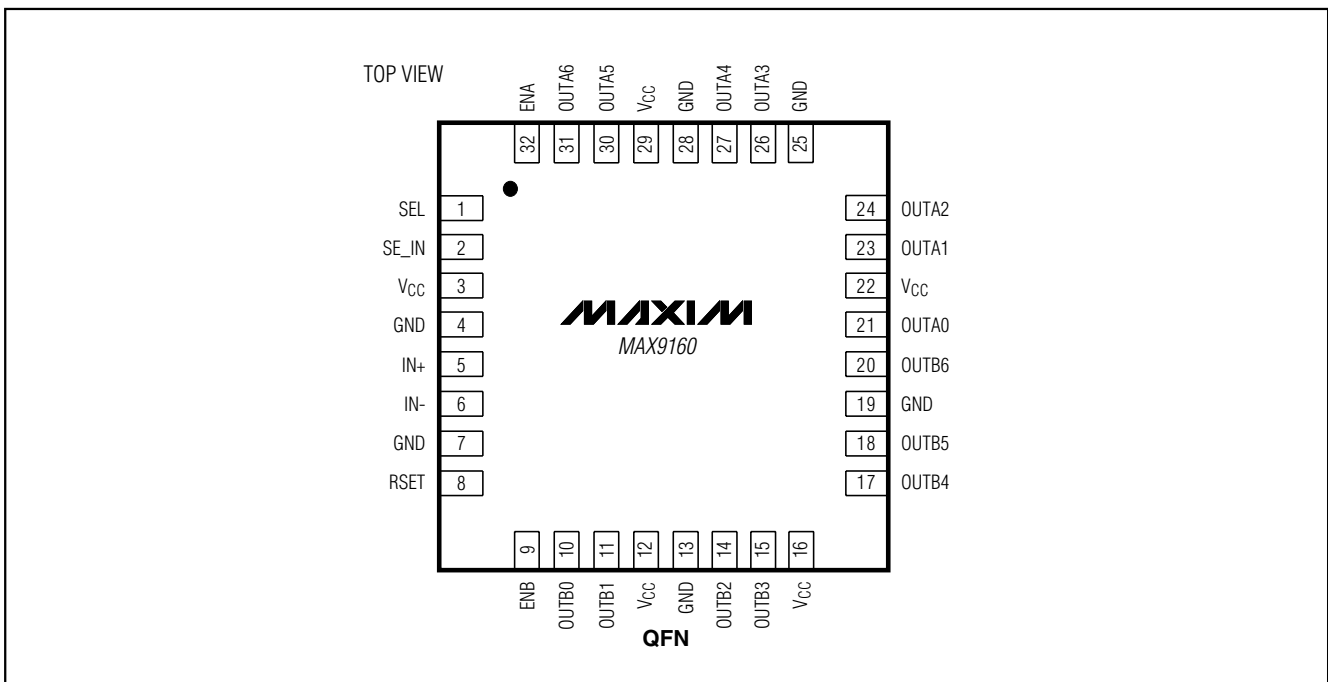

# LVDS or LVTTTL/LVCMOS Input to 14 LVTTTL/LVCMOS Output Clock Driver

## Package Information

(The package drawing(s) in this data sheet may not reflect the most current specifications. For the latest package outline information, go to [www.maxim-ic.com/packages](http://www.maxim-ic.com/packages).)

**MAX9160**

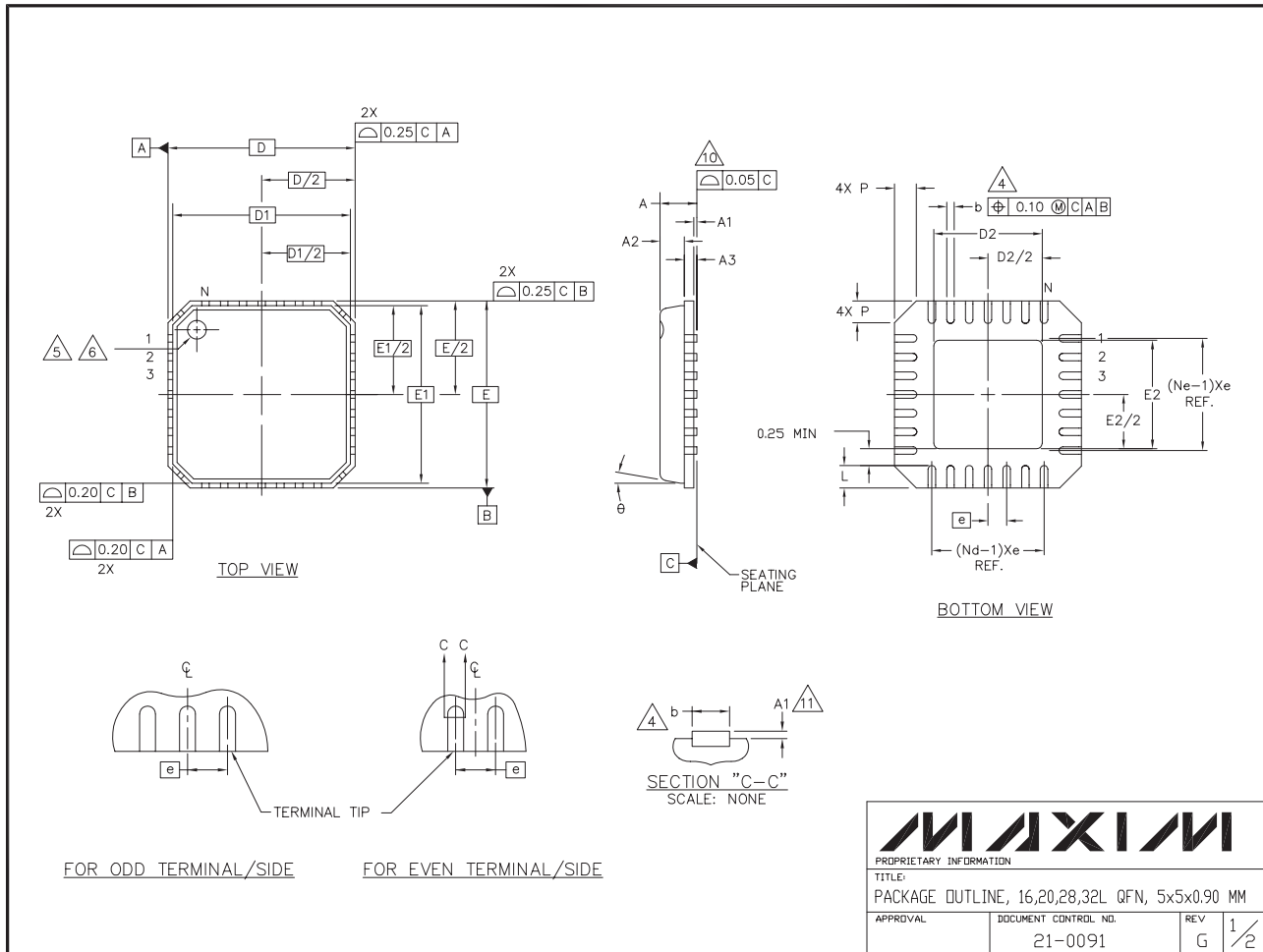

# LVDS or LVTTTL/LVCMOS Input to 14 LVTTTL/LVCMOS Output Clock Driver

## Package Information (continued)

(The package drawing(s) in this data sheet may not reflect the most current specifications. For the latest package outline information, go to [www.maxim-ic.com/packages](http://www.maxim-ic.com/packages).)

### NOTES:

1. DIE THICKNESS ALLOWABLE IS 0.305mm MAXIMUM (.012 INCHES MAXIMUM)
2. DIMENSIONING & TOLERANCES CONFORM TO ASME Y14.5M. - 1994.
3. N IS THE NUMBER OF TERMINALS.  
Nd IS THE NUMBER OF TERMINALS IN X-DIRECTION &  
Ne IS THE NUMBER OF TERMINALS IN Y-DIRECTION.
4. DIMENSION b APPLIES TO PLATED TERMINAL AND IS MEASURED BETWEEN 0.20 AND 0.25mm FROM TERMINAL TIP.
5. THE PIN #1 IDENTIFIER MUST BE EXISTED ON THE TOP SURFACE OF THE PACKAGE BY USING INDENTATION MARK OR INK/ LASER MARKED.
6. EXACT SHAPE AND SIZE OF THIS FEATURE IS OPTIONAL.
7. ALL DIMENSIONS ARE IN MILLIMETERS.
8. PACKAGE WARPAGE MAX 0.05mm.
9. APPLIED FOR EXPOSED PAD AND TERMINALS.  
EXCLUDE EMBEDDED PART OF EXPOSED PAD FROM MEASURING.
10. MEETS JEDEC MO220.
11. THIS PACKAGE OUTLINE APPLIES TO ANVIL SINGULATION (STEPPED SIDES) AND TO SAW SINGULATION (STRAIGHT SIDES) QFN STYLES.

SYMBOL	COMMON DIMENSIONS			No. of Terminals
	MIN.	NOM.	MAX.	
A	0.80	0.90	1.00	
A1	0.00	0.01	0.05	
A2	0.00	0.65	1.00	
A3	0.20 REF.			
D	5.00 BSC			
D1	4.75 BSC			
E	5.00 BSC			
E1	4.75 BSC			
θ	0°	-	12°	
P	0	-	0.60	
D2	1.25	-	3.25	
E2	1.25	-	3.25	

SYMBOL	PITCH VARIATION B			No. of Terminals	SYMBOL	PITCH VARIATION B			No. of Terminals	SYMBOL	PITCH VARIATION C			No. of Terminals	SYMBOL	PITCH VARIATION D			No. of Terminals
	MIN.	NOM.	MAX.			MIN.	NOM.	MAX.			MIN.	NOM.	MAX.			MIN.	NOM.	MAX.	
ⓐ	0.80 BSC			3	ⓐ	0.65 BSC			3	ⓐ	0.50 BSC			3	ⓐ	0.50 BSC			3
N	16			3	N	20			3	N	28			3	N	32			3
Nd	4			3	Nd	5			3	Nd	7			3	Nd	8			3
Ne	4			3	Ne	5			3	Ne	7			3	Ne	8			3
L	0.35	0.55	0.75	4	L	0.35	0.55	0.75	4	L	0.35	0.55	0.75	4	L	0.30	0.40	0.50	4
b	0.28	0.33	0.40	4	b	0.23	0.28	0.35	4	b	0.18	0.23	0.30	4	b	0.18	0.23	0.30	4

PROPRIETARY INFORMATION			
TITLE PACKAGE OUTLINE, 16,20,28,32L QFN, 5x5x0.90 MM			
APPROVAL	DOCUMENT CONTROL NO.	REV	2/2
	21-0091	G	

# LVDS or LVTTTL/LVCMOS Input to 14 LVTTTL/LVCMOS Output Clock Driver

## Package Information (continued)

(The package drawing(s) in this data sheet may not reflect the most current specifications. For the latest package outline information, go to [www.maxim-ic.com/packages](http://www.maxim-ic.com/packages).)

MAX9160

TSSOP, 4.0 EXP PADS, EPS

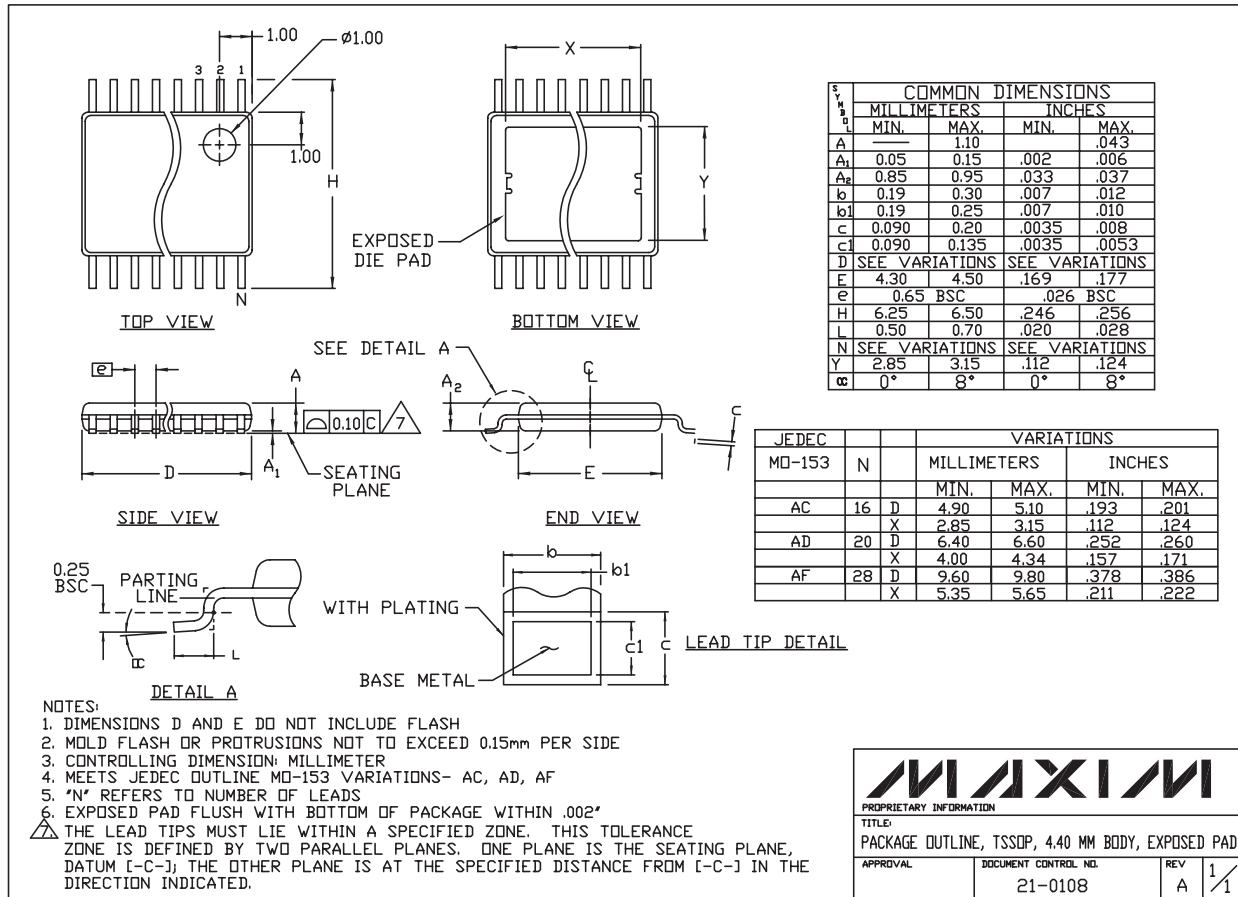

Maxim cannot assume responsibility for use of any circuitry other than circuitry entirely embodied in a Maxim product. No circuit patent licenses are implied. Maxim reserves the right to change the circuitry and specifications without notice at any time.

Maxim Integrated Products, 120 San Gabriel Drive, Sunnyvale, CA 94086 408-737-7600 13

## Looking for pricing, stock, or lifecycle information?

Click below to explore more details on WIN SOURCE:

- ⊖ [View MAX9160EUI+T on WIN SOURCE](#)
- ⊖ [Maxim Integrated Information](#)

## Optimize Your Supply Chain with WIN SOURCE Solutions

- ✓ Global Sourcing Solution
- ✓ Obsolete Management
- ✓ Cost Control Management
- ✓ Shortage Management
- ✓ Alternative Solution
- ✓ Excess Inventory Management