



EVALUATION KIT  
AVAILABLE

# High-Voltage, Dual-Input, USB/AC Adapter Chargers in 2mm x 3mm TDFN

## General Description

The MAX8804V/MAX8804W/MAX8804Y/MAX8804Z intelligent, dual-input, stand-alone, constant-current, constant-voltage (CCCV), thermally regulated linear chargers are designed for a single-cell lithium-ion (Li+) battery. They integrate the current-sense circuit, MOS pass element, thermal-regulation circuitry, and overvoltage protection (OVP), and eliminate the reverse-blocking Schottky diode.

The MAX8804V/MAX8804W/MAX8804Z function as stand-alone chargers to control the charging sequence from the prequalification state through fast-charge, top-off charge, and full-charge indication. The MAX8804Y eliminates the prequalification state to allow startup into a load without a battery. Proprietary thermal-regulation circuitry limits the die temperature when fast-charging or while exposed to high ambient temperatures, allowing maximum charging current without damaging the IC.

The MAX8804V/MAX8804W/MAX8804Y/MAX8804Z achieve high flexibility by providing an adjustable DC/USB fast-charge current through a simple single-wire interface (SET input). The chargers automatically select between either a USB or AC adapter input source. The AC adapter charge current is programmable from 400mA to 700mA in 50mA steps through a serial interface. The USB charge current is programmable to 95mA, 380mA, or 475mA through the same interface. Other features include an active-low battery charging-status indicator ( $\overline{\text{CHG}}$ ), an active-low power-OK indicator ( $\overline{\text{POK}}$ ), an active-low USB input detection output (USBPWR) on the MAX8804Y/MAX8804Z, and battery pack detection (DETBAT) on the MAX8804V/MAX8804W.

The MAX8804V has 120mA, 140mA, 180mA, and 200mA  $\overline{\text{CHG}}$  top-off threshold settings, while the MAX8804W/MAX8804Y/MAX8804Z have 70mA, 80mA, 90mA, and 100mA.

The MAX8804V/MAX8804W/MAX8804Y/MAX8804Z accept a 4.15V to 30V DC source voltage or a 4.15V to 16V USB input voltage, but disable charging when either input voltage exceeds 7.5V to protect against unqualified or faulty input sources. The MAX8804V/MAX8804W/MAX8804Y/MAX8804Z operate over the extended temperature range (-40°C to +85°C) and are available in a tiny 8-pin thermally enhanced 2mm x 3mm TDFN package.

## Applications

Cell Phones/Smartphones MP3 Players  
Digital Cameras Other Handheld Devices  
Portable Media Players

Pin Configuration appears at end of data sheet.



For pricing, delivery, and ordering information, please contact Maxim Direct at 1-888-629-4642, or visit Maxim's website at [www.maxim-ic.com](http://www.maxim-ic.com).

## Features

- ◆ Complete Chargers for Single-Cell Li+ Battery
- ◆ Dual-Input, 30V AC Adapter/16V USB
- ◆ No External FET, Blocking Diode, or Sense Resistor Required
- ◆ Automatic USB/AC Adapter Input Selection
- ◆ Easy Programmable Fast-Charge Current and Top-Off Threshold
- ◆ Proprietary Die Temperature Regulation Control
- ◆  $\pm 5\%$  Fast-Charge Current-Limit Accuracy
- ◆ Battery Pack Detection Input (MAX8804V/MAX8804W)
- ◆ Power-Present and Charger-Status Outputs
- ◆ No Prequalification Charge (MAX8804Y)
- ◆ Tiny 2mm x 3mm Thermally Enhanced TDFN Package

## Ordering Information

PART	PIN-PACKAGE	TOP MARK
MAX8804VETA+	8 TDFN-EP*	AAQ
MAX8804WETA+	8 TDFN-EP*	AAP
MAX8804YETA+	8 TDFN-EP*	AAD
MAX8804ZETA+	8 TDFN-EP*	AAC

\*EP = Exposed paddle.

+ Denotes a lead-free package.

Note: All devices are specified to operate over the -40°C to +85°C operating temperature range.

## Typical Application Circuit

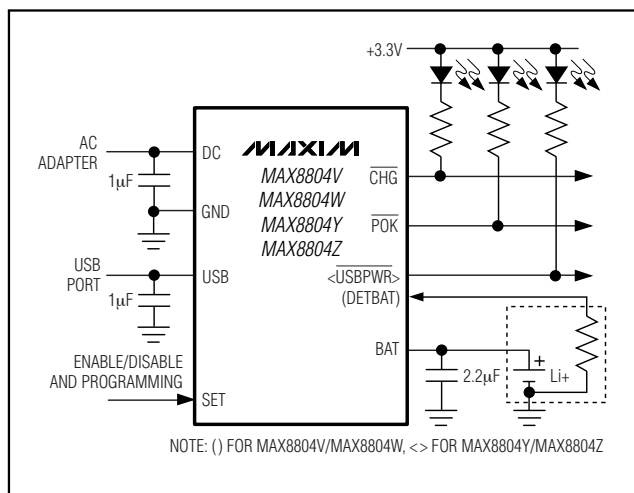

MAX8804V/MAX8804W/MAX8804Y/MAX8804Z

# High-Voltage, Dual-Input, USB/AC Adapter Chargers in 2mm x 3mm TDFN

## ABSOLUTE MAXIMUM RATINGS

DC to GND .....	-0.3V to +30V	Operating Temperature Range .....	-40°C to +85°C
USB to GND .....	-0.3V to +16V	Junction Temperature .....	+150°C
BAT, CHG, SET, POK, USBPWR, DETBAT to GND.....	-0.3V to +5.5V	Storage Temperature Range .....	-65°C to +150°C
Continuous Power Dissipation (T <sub>A</sub> = +70°C)		Lead Temperature (soldering, 10s) .....	+300°C
8-Pin TDFN 2mm x 3mm (derate 16.7mW/°C above +70°C)			
(multilayer board) .....	1333mW		

Stresses beyond those listed under "Absolute Maximum Ratings" may cause permanent damage to the device. These are stress ratings only, and functional operation of the device at these or any other conditions beyond those indicated in the operational sections of the specifications is not implied. Exposure to absolute maximum rating conditions for extended periods may affect device reliability.

## ELECTRICAL CHARACTERISTICS

(V<sub>DC</sub> = 5V, V<sub>SET</sub> = 0V) or (V<sub>USB</sub> = 5V, V<sub>SET</sub> = 5V), V<sub>BAT</sub> = unconnected, V<sub>DETBAT</sub> = 0V (MAX8804V/MAX8804W), T<sub>A</sub> = -40°C to +85°C, unless otherwise noted.) (Note 1)

PARAMETER	CONDITIONS		MIN	TYP	MAX	UNITS
<b>DC AND USB</b>						
DC Input Voltage Range			0		28	V
USB Input Voltage Range			0		14	V
Input Operating Range	(Notes 2, 3)		4.15		7.00	V
Input Undervoltage Threshold	V <sub>IN</sub> rising, 500mV hysteresis (typ) (Note 2)		3.85	4.0	4.15	V
Input Overvoltage Threshold	V <sub>IN</sub> rising, 200mV hysteresis (typ) (Note 2)		7.2	7.5	7.8	V
DC Input Supply Current	V <sub>USB</sub> = 0V, I <sub>BAT</sub> = 0mA, charge mode			800	1200	μA
	V <sub>SET</sub> = 5V, standby mode			300	550	
	V <sub>DC</sub> = V <sub>BAT</sub> = 4.3V, shutdown mode			300	550	
USB Input Supply Current	V <sub>DC</sub> = 0V, V <sub>SET</sub> = 5V, I <sub>BAT</sub> = 0mA, charge mode			800	1200	μA
	V <sub>SET</sub> = 0V, standby mode			300	550	
	V <sub>USB</sub> = V <sub>BAT</sub> = 4.3V, shutdown mode			300	550	
DC to BAT On-Resistance	V <sub>DC</sub> = 3.7V, V <sub>BAT</sub> = 3.6V			0.55	1.0	Ω
USB to BAT On-Resistance	V <sub>USB</sub> = 3.7V, V <sub>BAT</sub> = 3.6V			0.65	1.2	Ω
Input to BAT Comparator Threshold (Note 2)	V <sub>IN</sub> rising		145	260	385	mV
	V <sub>IN</sub> falling			55		
<b>BAT</b>						
BAT Regulation Voltage	I <sub>BAT</sub> = 0mA	T <sub>A</sub> = +25°C	4.179	4.200	4.221	V
		T <sub>A</sub> = -40°C to +85°C	4.158	4.200	4.242	
Battery Removal Detection Threshold	V <sub>BAT</sub> rising		4.40	4.67	4.90	V
	Hysteresis			0.1		
DC Charging Current	V <sub>USB</sub> = 0V, V <sub>BAT</sub> = 3.6V, rising edge detection on SET (MAX8804Y/ MAX8804Z)	Default and 1st to 3rd interface pulse	475	500	525	mA
		4th to 7th interface pulse	523	550	578	
		8th to 11th interface pulse	570	600	630	
		12th to 15th interface pulse	428	450	473	
		16th to 19th interface pulse	380	400	420	
		20th to 23rd interface pulse	618	650	683	
		24th to 27th interface pulse	665	700	735	

# High-Voltage, Dual-Input, USB/AC Adapter Chargers in 2mm x 3mm TDFN

## ELECTRICAL CHARACTERISTICS (continued)

(( $V_{DC} = 5V$ ,  $V_{SET} = 0V$ ) or ( $V_{USB} = 5V$ ,  $V_{SET} = 5V$ ),  $V_{BAT}$  = unconnected,  $V_{DETBAT} = 0V$  (MAX8804V/MAX8804W),  $T_A = -40^{\circ}C$  to  $+85^{\circ}C$ , unless otherwise noted.) (Note 1)

PARAMETER	CONDITIONS		MIN	TYP	MAX	UNITS	
DC Charging Current	$V_{USB} = 0V$ , $V_{BAT} = 3.6V$ , rising edge detection on SET (MAX8804V/ MAX8804W)	Default and 1st to 3rd interface pulse	428	450	473	mA	
		4th to 7th interface pulse	523	550	578		
		8th to 11th interface pulse	475	500	525		
		12th to 15th interface pulse	380	400	420		
		16th to 19th interface pulse	570	600	630		
		20th to 23th interface pulse	618	650	683		
		24th to 27th interface pulse	665	700	735		
USB Charging Current	$V_{DC} = 0V$ , $V_{BAT} = 3.6V$ , rising edge detection on SET (MAX8804Y/ MAX8804Z)	Default	90	95	100	mA	
		1st interface pulse	360	380	400		
		2nd interface pulse	450	475	500		
	$V_{DC} = 0V$ , $V_{BAT} = 3.6V$ , rising edge detection on SET (MAX8804V/ MAX8804W)	Default	360	380	400		
		1st interface pulse	450	475	500		
		2nd interface pulse	90	95	100		
Soft-Start Time	Ramping time from 0 to 500mA			250		$\mu s$	
BAT Prequal Threshold	MAX8804V/MAX8804W/MAX8804Z only, $V_{BAT}$ rising, 300mV hysteresis (typ)		2.35	2.50	2.65	V	
BAT Prequal Charge Current	MAX8804V/MAX8804W/MAX8804Z only			95		mA	
BAT Leakage Current	$V_{DC} = V_{USB} = 0V$ , $V_{BAT} = 4.2V$				2	$\mu A$	
<b>SET</b>							
Logic Input Thresholds	$V_{SET}$ rising				1.6	V	
	$V_{SET}$ falling		0.4				
Logic-High Time	Pulse width required to program DC charge current		1		1000	$\mu s$	
Logic-Low Time	Pulse width required to program USB charge current		1		1000	$\mu s$	
SET DC Mode Shutdown Delay	$V_{USB} = 0V$ , $V_{DC} = 5V$ , measured from $V_{SET}$ low to high		1.5	2	2.5	ms	
SET USB Mode Shutdown Delay	$V_{DC} = 0V$ , $V_{USB} = 5V$ , measured from $V_{SET}$ high to low		1.5	2	2.5	ms	
SET Internal Pulldown Resistor				2	4	M $\Omega$	
<b>POK, CHG, USBPWR (USBPWR only for MAX8804Y/MAX8804Z)</b>							
Logic Output-Voltage Low	$I_{POK} = I_{CHG} = I_{USBPWR} = 5mA$			60	500	mV	
Logic Output-Current High	$V_{POK} = V_{CHG} = V_{USBPWR} = 5.5V$ , $V_{DC} = V_{USB} = 0V$		$T_A = +25^{\circ}C$		0.001	1	$\mu A$
			$T_A = +85^{\circ}C$		0.01		
<b>DETBAT (MAX8804V/MAX8804W only)</b>							
Logic Input Theshold	Rising				1.6	V	
	Falling		0.4				
Pullup Resistor				63		k $\Omega$	

MAX8804V/MAX8804W/MAX8804Y/MAX8804Z

# High-Voltage, Dual-Input, USB/AC Adapter Chargers in 2mm x 3mm TDFN

## ELECTRICAL CHARACTERISTICS (continued)

(( $V_{DC} = 5V$ ,  $V_{SET} = 0V$ ) or ( $V_{USB} = 5V$ ,  $V_{SET} = 5V$ ),  $V_{BAT} = \text{unconnected}$ ,  $V_{DETBAT} = 0V$  (MAX8804V/MAX8804W),  $T_A = -40^\circ\text{C}$  to  $+85^\circ\text{C}$ , unless otherwise noted.) (Note 1)

PARAMETER	CONDITIONS		MIN	TYP	MAX	UNITS	
<b>CHG</b>							
$\overline{\text{CHG}}$ Top-Off Threshold (MAX8804W/MAX8804Y/MAX8804Z)	IBAT falling, battery is charged, rising edge on SET	$V_{DC} = 0V$ , $V_{USB} = 5V$	60	80	100	mA	
		$V_{DC} = 5V$ , $V_{USB} = 0V$	Default, 4th, 8th, 12th, 16th, 20th, 24th, 28th interface pulse	60	80		100
			1st, 5th, 9th, 13th, 17th, 21st, 25th interface pulse	67.5	90		112.5
			2nd, 6th, 10th, 14th, 18th, 22nd, 26th interface pulse	75	100		125
			3rd, 7th, 11th, 15th, 19th, 23rd, 27th interface pulse	52.7	70		87.5
$\overline{\text{CHG}}$ Top-Off Threshold (MAX8804V)	IBAT falling, battery is charged, rising edge on SET	$V_{DC} = 0V$ , $V_{USB} = 5V$	60	80	100	mA	
		$V_{DC} = 5V$ , $V_{USB} = 0V$	Default, 4th, 8th, 12th, 16th, 20th, 24th, 28th interface pulse	90	120		150
			1st, 5th, 9th, 13th, 17th, 21st, 25th interface pulse	105	140		175
			2nd, 6th, 10th, 14th, 18th, 22nd, 26th interface pulse	135	180		225
			3rd, 7th, 11th, 15th, 19th, 23rd, 27th interface pulse	150	200		250
$\overline{\text{CHG}}$ Hysteresis	IBAT rising after top-off is detected (Note 4)	DC mode	57			mA	
		USB mode	51				
$\overline{\text{CHG}}$ Detection Delay	IBAT falls below top-off threshold		3	4	5	ms	
<b>THERMAL LOOP</b>							
Thermal-Regulation Set Point	Junction temperature when the charge current is reduced, $T_J$ rising		+105			$^\circ\text{C}$	
Thermal-Regulation Gain	Reduction of IBAT for increase of $T_J$	DC charging	-40			mA/ $^\circ\text{C}$	
		USB charging	-24				

**Note 1:** Devices are 100% production tested at  $T_A = +25^\circ\text{C}$ . Limits over the operating temperature range are guaranteed by design and characterization.

**Note 2:**  $V_{IN}$  refers to the input for the IC. For the MAX8804V/MAX8804W/MAX8804Y/MAX8804Z,  $V_{IN}$  is  $V_{DC}$  with  $V_{USB} = 0V$  or  $V_{USB}$  with  $V_{DC} = 0V$ .

**Note 3:** Guaranteed by undervoltage and overvoltage threshold testing. For charge completion, the input voltage must be greater than 4.28V.

**Note 4:** This hysteresis is for all charge current except 95mA. In the case of 95mA charge current, voltage-mode to current-mode detection gives indication of charge mode.

# High-Voltage, Dual-Input, USB/AC Adapter Chargers in 2mm x 3mm TDFN

## Typical Operating Characteristics

( $V_{BAT} = 3.6V$ ; DC charge mode:  $V_{DC} = 5V$ ,  $V_{USB} = 0V$ ,  $V_{DETBAT} = 0V$  (MAX8804Y/MAX8804Z only),  $V_{SET} = 0V$  or unconnected; USB charge mode:  $V_{USB} = 5V$ ,  $V_{DC} = 0V$ ,  $V_{SET} = 5V$ ;  $T_A = +25^\circ C$ , unless otherwise noted.)

MAX8804V/MAX8804W/MAX8804Y/MAX8804Z

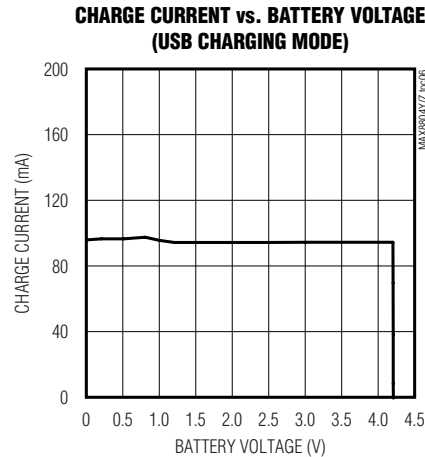
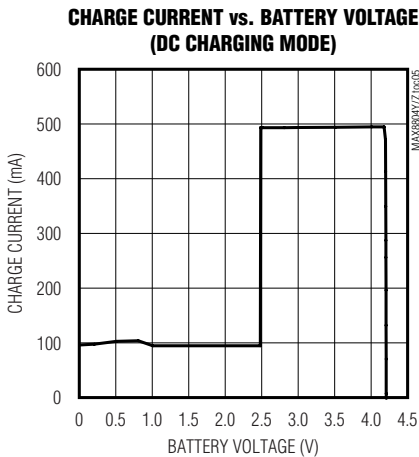
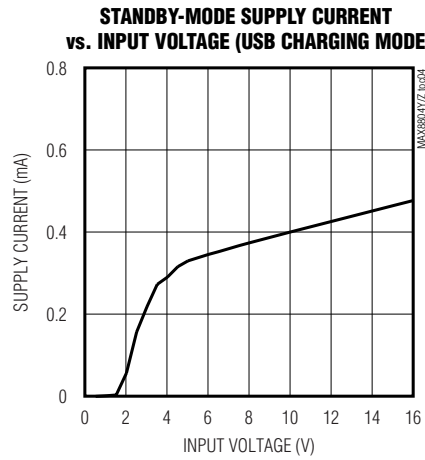
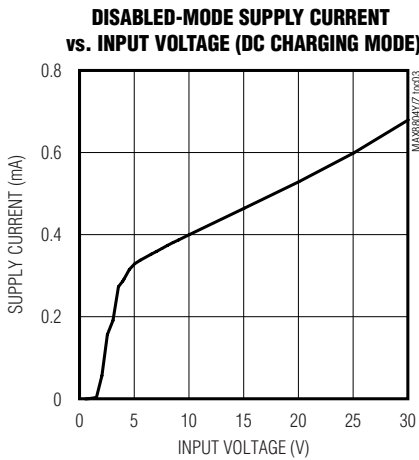
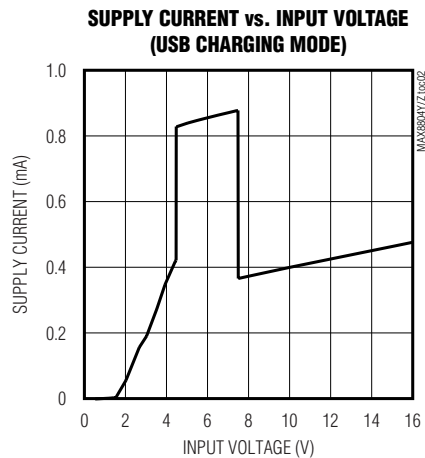
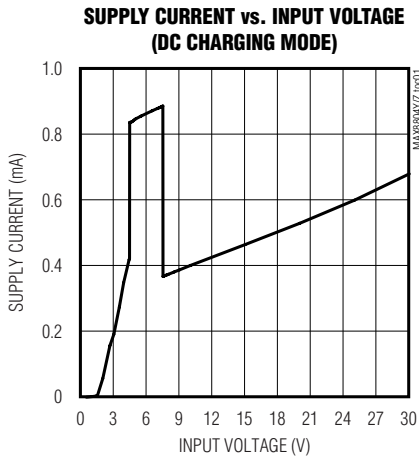

# High-Voltage, Dual-Input, USB/AC Adapter Chargers in 2mm x 3mm TDFN

## Typical Operating Characteristics (continued)

( $V_{BAT} = 3.6V$ ; DC charge mode:  $V_{DC} = 5V$ ,  $V_{USB} = 0V$ ,  $V_{DETBAT} = 0V$  (MAX8804Y/MAX8804Z only),  $V_{SET} = 0V$  or unconnected; USB charge mode:  $V_{USB} = 5V$ ,  $V_{DC} = 0V$ ,  $V_{SET} = 5V$ ;  $T_A = +25^\circ C$ , unless otherwise noted.)

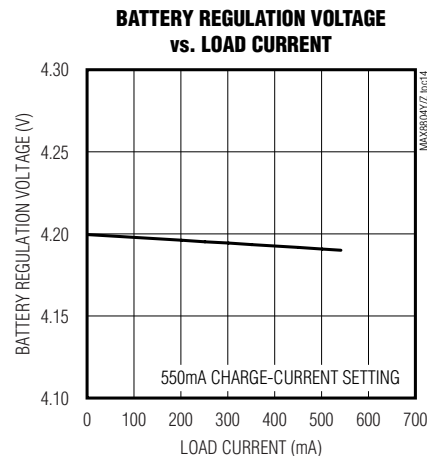
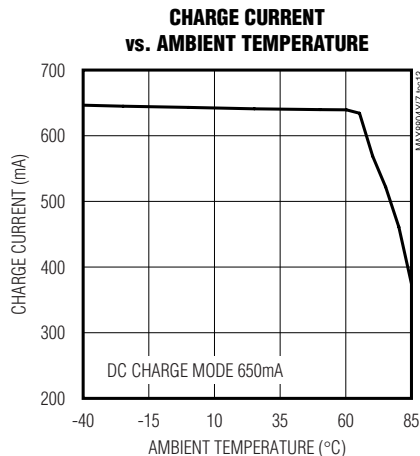
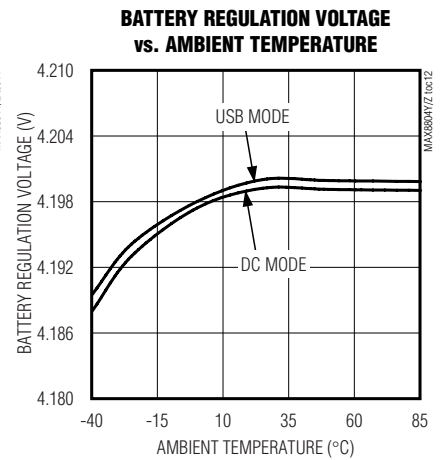
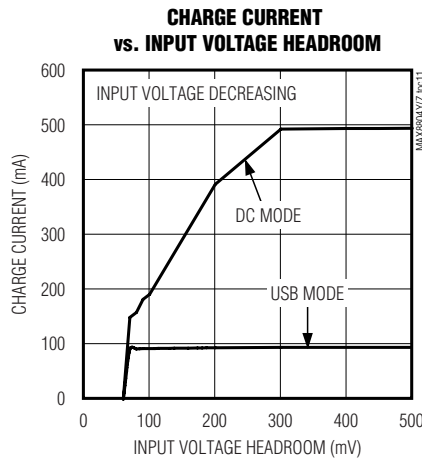
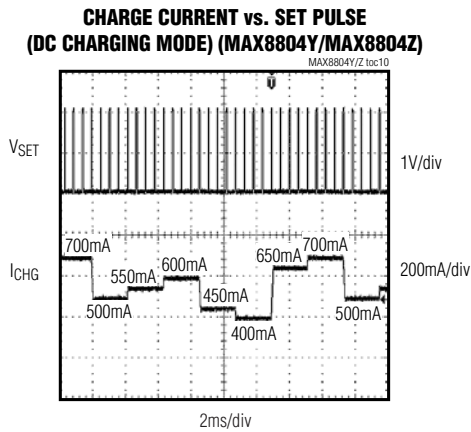
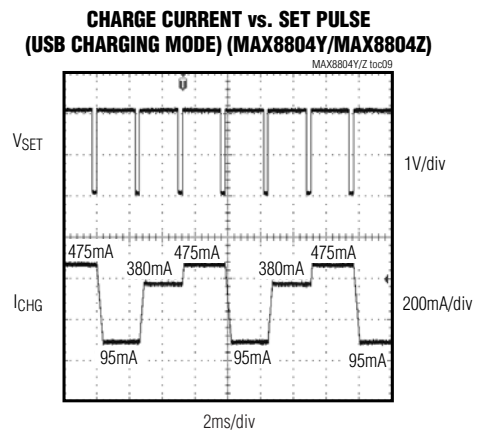
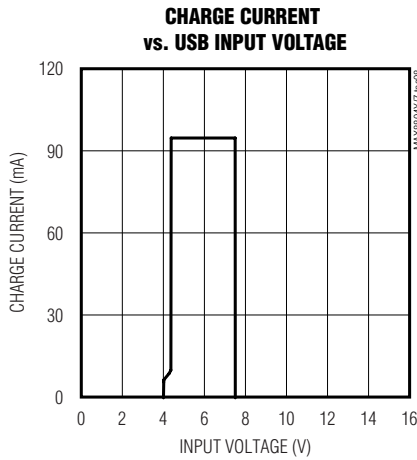
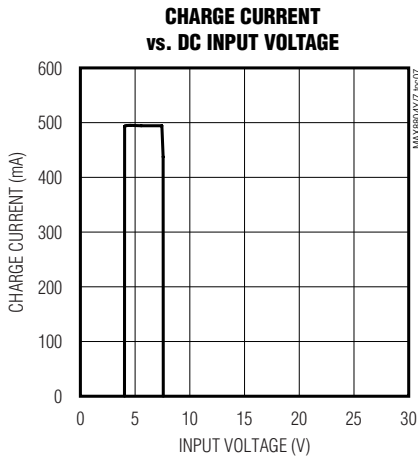

# High-Voltage, Dual-Input, USB/AC Adapter Chargers in 2mm x 3mm TDFN

## Pin Description

PIN		NAME	FUNCTION
MAX8804V/ MAX8804W	MAX8804Y/ MAX8804Z		
1	1	BAT	Battery Connection. The IC delivers charging current and monitors battery voltage using BAT. Bypass BAT to GND with a 2.2µF or larger ceramic capacitor. BAT is high impedance when the IC is disabled.
2	—	DETBAT	Battery Pack Detection Input. Drive DETBAT low or connect it to GND to allow SET to control the charger. Leave DETBAT unconnected to disable any charge mode.
—	2	$\overline{\text{USBPWR}}$	USB Input Detection Output. $\overline{\text{USBPWR}}$ is internally pulled low if a valid voltage is present at USB, otherwise it is high impedance. $\overline{\text{USBPWR}}$ circuitry is active regardless of SET and charger on/off status.
3	3	$\overline{\text{POK}}$	Power-OK Monitor. $\overline{\text{POK}}$ is an open-drain output that is internally pulled low when a valid charging source is detected at either DC or USB. $\overline{\text{POK}}$ is high impedance when both input voltages are less than $V_{UVLO}$ or $V_{BAT}$ .
4	4	DC	DC Input Supply. Connect DC to a 4.15V to 7V charging source. Bypass DC to GND with a 1µF or larger ceramic capacitor. DC takes priority over USB when both are valid.
5	5	USB	USB Input Source. Connect USB to a USB port. Bypass USB to GND with a 1µF or larger ceramic capacitor.
6	6	$\overline{\text{CHG}}$	Charging-Status Output. $\overline{\text{CHG}}$ is internally pulled low when the battery is being charged. $\overline{\text{CHG}}$ is high impedance when the charger is in top-off mode or disabled.
7	7	SET	Enable/Disable, Charging Current, and Top-Off Threshold Set Input. Drive SET low to enable DC charge mode and drive high to enable USB charge mode. If both DC and USB inputs are present, SET is used for the DC charge mode only and USB charge is disabled. SET is also used for programming the charge current and top-off threshold. See the <i>DC/USB Mode and Charging Current Setting</i> section for details.
8	8	GND	Ground
—	—	EP	Exposed Paddle. Connect to the GND plane for optimum thermal dissipation.

MAX8804V/MAX8804W/MAX8804Y/MAX8804Z

# High-Voltage, Dual-Input, USB/AC Adapter Chargers in 2mm x 3mm TDFN

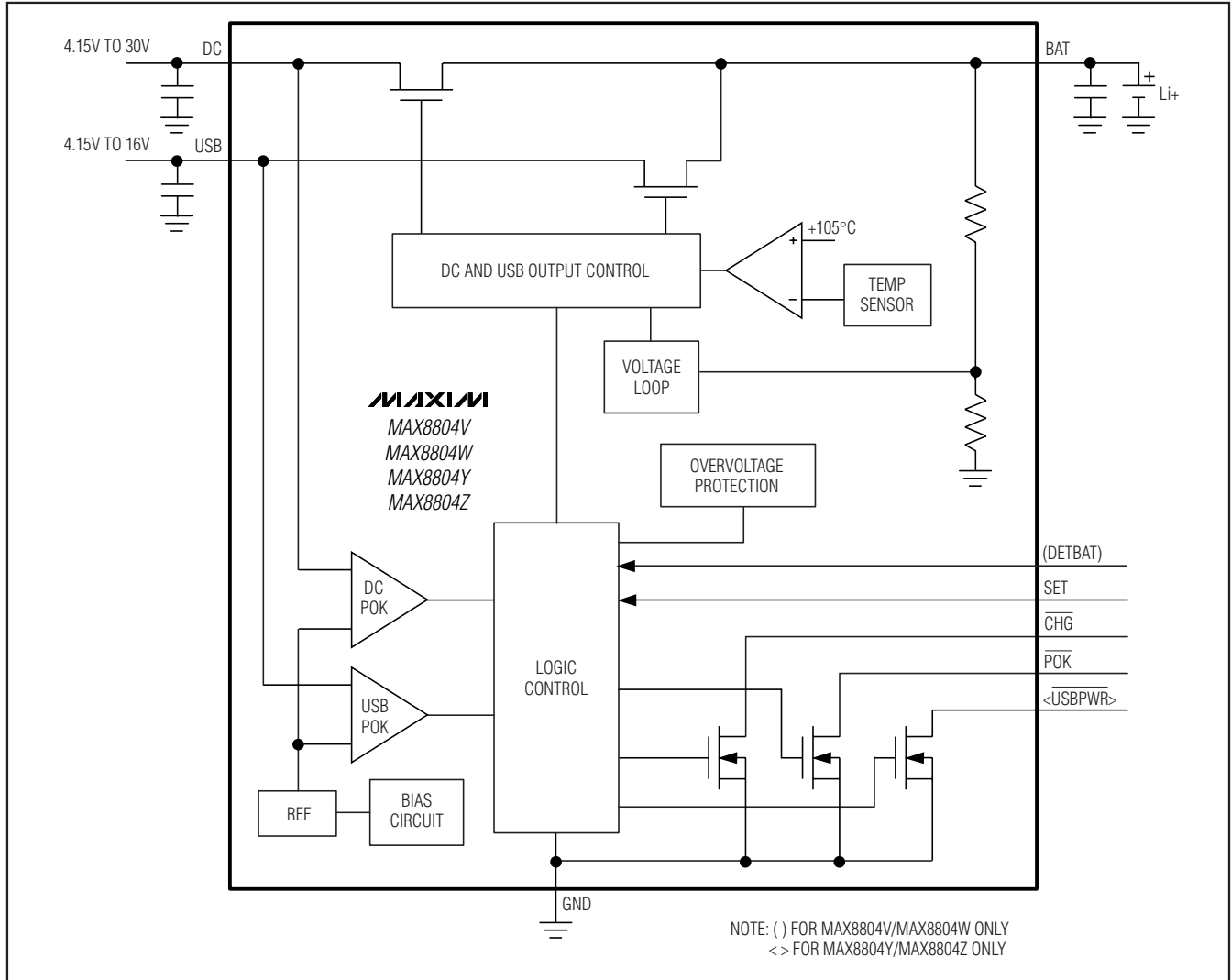

Figure 1. Functional Diagram

## Detailed Description

The MAX8804V/MAX8804W/MAX8804Y/MAX8804Z dual-input linear battery chargers use voltage, current, and thermal-control loops to charge and protect a single Li+ battery. When a Li+ battery with a cell voltage below 2.5V is inserted, the MAX8804V/MAX8804W/MAX8804Z chargers enter the prequalification stage where they precharge that cell with 95mA (Figure 2). The CHG indicator output is driven low to indicate entry into the prequalification state. When battery voltage exceeds 2.5V, the charger soft-starts as it enters the fast-charge stage. The MAX8804Y eliminates the prequalification state and enters fast-charge when the battery is inserted. The fast-charge current level is programmed by a simple single-

wire interface. As the battery voltage approaches 4.2V, the charging current is reduced. If the battery current drops below the top-off current threshold, the CHG indicator goes high impedance, signaling that the battery is fully charged. The ICs then enter a constant voltage-regulation mode to maintain the battery at full charge.

The MAX8804V/MAX8804W/MAX8804Y/MAX8804Z automatically select between either a USB or AC adapter input source. The AC adapter charge current is programmable from 400mA to 700mA in 50mA steps through a simple single-wire interface (see Tables 2, 3, and 4). The USB charge current is programmable to 95mA, 380mA, or 475mA through the same interface (see Tables 5 and 6).

# High-Voltage, Dual-Input, USB/AC Adapter Chargers in 2mm x 3mm TDFN

MAX8804V/MAX8804W/MAX8804Y/MAX8804Z

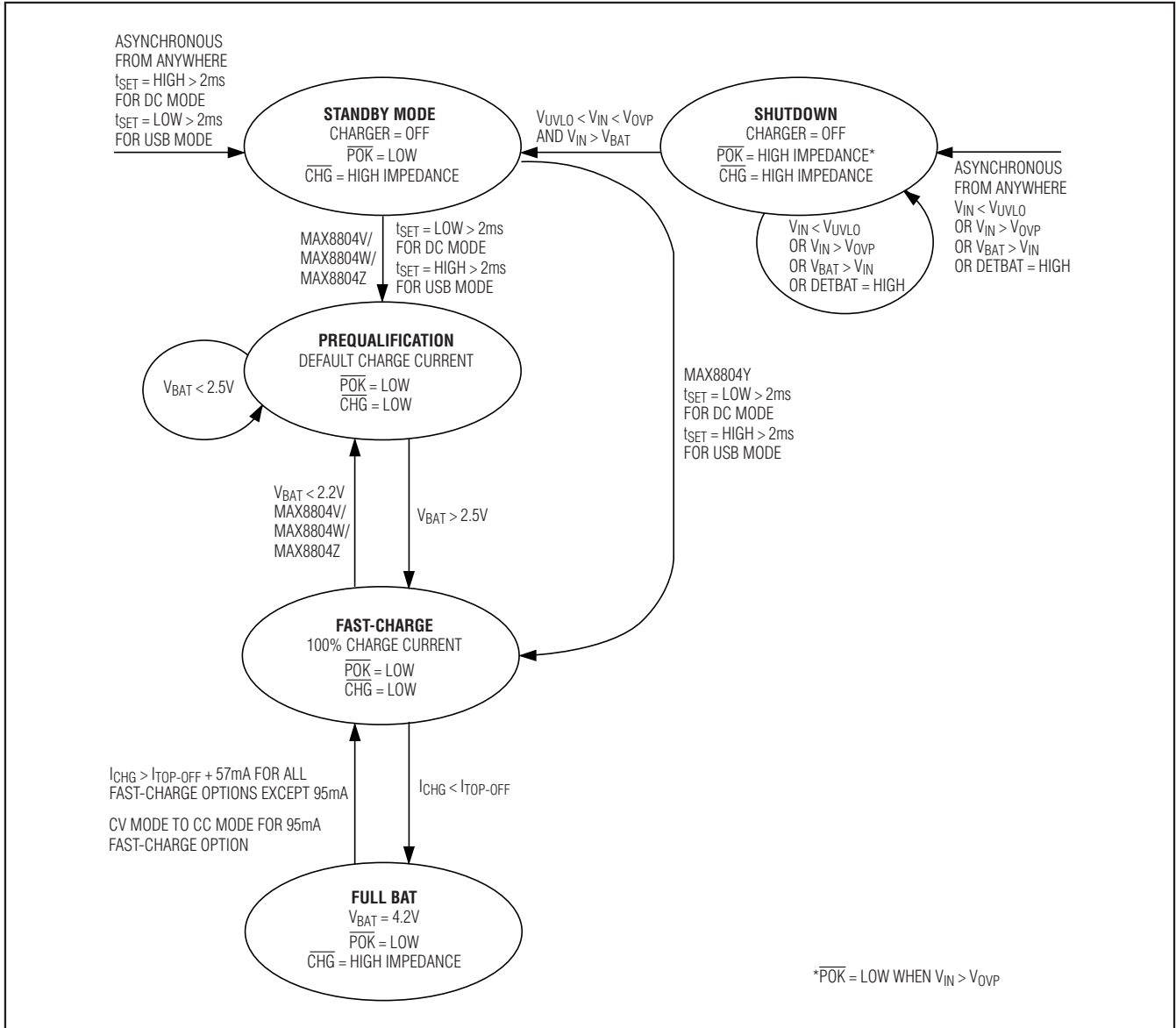

Figure 2. Charger State Diagram

## DC Charging

The MAX8804V/MAX8804W/MAX8804Y/MAX8804Z are designed to charge a single-cell Li+ battery from a DC source voltage between 4.15V and 7V and withstand up to 30V maximum input voltage. The charge current and top-off threshold are programmed with the SET input.

## USB Charging

The MAX8804V/MAX8804W/MAX8804Y/MAX8804Z contain a USB input that allows operation from a USB port with voltages between 4.15V and 7V and can withstand up to 16V maximum input voltage. Pulsing SET allows programming a 95mA, 380mA, or 475mA maximum charging current when using the USB input.

# High-Voltage, Dual-Input, USB/AC Adapter Chargers in 2mm x 3mm TDFN

Table 1. SET Truth Table

SET	V <sub>DC</sub>	V <sub>USB</sub>	CHARGER STATUS
0	Invalid	Invalid	Off
0	Invalid	Valid	Off
0	Valid	Invalid	DC charging mode enabled, USB charging mode disabled
0	Valid	Valid	DC charging mode enabled, USB charging mode disabled
1	Invalid	Invalid	Off
1	Invalid	Valid	DC charging mode disabled, USB charging mode enabled
1	Valid	Invalid	Off
1	Valid	Valid	Off

**Note:** This table is true when DETBAT = LOW for the MAX8804V/MAX8804W. When DETBAT = HIGH, the MAX8804W enters shutdown.

## DC/USB Mode and Charging Current Setting

SET is a logic input that sets DC/USB charging mode and charging current. Drive SET low or leave it unconnected to enable DC charging mode. Drive SET high to enable USB charging mode (see Table 1). SET can also be driven by series pulses to program the charging current in both DC and USB mode.

## DC Charge Mode

Drive SET low or leave it unconnected to enable DC charging mode. Subsequent pulses on SET program the charging current and the top-off threshold. There are seven fast-charge current options and four top-off threshold options. Pulse SET high (1 $\mu$ s to 1ms pulse width) subsequently to realize charging current and top-off threshold programming and transition. After the 28th pulse, the MAX8804V/ MAX8804W/MAX8804Y/ MAX8804Z go into the default mode and start a new cycle. See Tables 2, 3, and 4 and Figure 3 to set the desired charging current and top-off threshold. Drive SET high longer than 2ms to disable the DC charging-control circuitry.

Table 2. MAX8804Y/MAX8804Z DC Charging Current Programming by Series Pulses

PULSE NUMBER	DEFAULT	1st	2nd	3rd	4th	5th	6th	7th	8th	9th	10th	11th	12th	13th	14th
I <sub>CHG</sub> (mA)	500	500	500	500	550	550	550	550	600	600	600	600	450	450	450
Top-Off Current Threshold (mA)	80	90	100	70	80	90	100	70	80	90	100	70	80	90	100
PULSE NUMBER	—	15th	16th	17th	18th	19th	20th	21st	22nd	23rd	24th	25th	26th	27th	28th
I <sub>CHG</sub> (mA)	—	450	400	400	400	400	650	650	650	650	700	700	700	700	500
Top-Off Current Threshold (mA)	—	70	80	90	100	70	80	90	100	70	80	90	100	70	80

Table 3. MAX8804W DC Charging Current Programming by Series Pulses

PULSE NUMBER	DEFAULT	1st	2nd	3rd	4th	5th	6th	7th	8th	9th	10th	11th	12th	13th	14th
I <sub>CHG</sub> (mA)	450	450	450	450	550	550	550	550	500	500	500	500	400	400	400
Top-Off Current Threshold (mA)	80	90	100	70	80	90	100	70	80	90	100	70	80	90	100
PULSE NUMBER	—	15th	16th	17th	18th	19th	20th	21st	22nd	23rd	24th	25th	26th	27th	28th
I <sub>CHG</sub> (mA)	—	400	600	600	600	600	650	650	650	650	700	700	700	700	450
Top-Off Current Threshold (mA)	—	70	80	90	100	70	80	90	100	70	80	90	100	70	80

# High-Voltage, Dual-Input, USB/AC Adapter Chargers in 2mm x 3mm TDFN

MAX8804V/MAX8804W/MAX8804Y/MAX8804Z

Table 4. MAX8804V DC Charging Current Programming by Series Pulses

PULSE NUMBER	DEFAULT	1st	2nd	3rd	4th	5th	6th	7th	8th	9th	10th	11th	12th	13th	14th
I <sub>CHG</sub> (mA)	450	450	450	450	550	550	550	550	500	500	500	500	400	400	400
Top-Off Current Threshold (mA)	120	140	180	200	120	140	180	200	120	140	180	200	120	140	180
PULSE NUMBER	—	15th	16th	17th	18th	19th	20th	21st	22nd	23rd	24th	25th	26th	27th	28th
I <sub>CHG</sub> (mA)	—	400	600	600	600	600	650	650	650	650	700	700	700	700	450
Top-Off Current Threshold (mA)	—	200	120	140	180	200	120	140	180	200	120	140	180	200	120

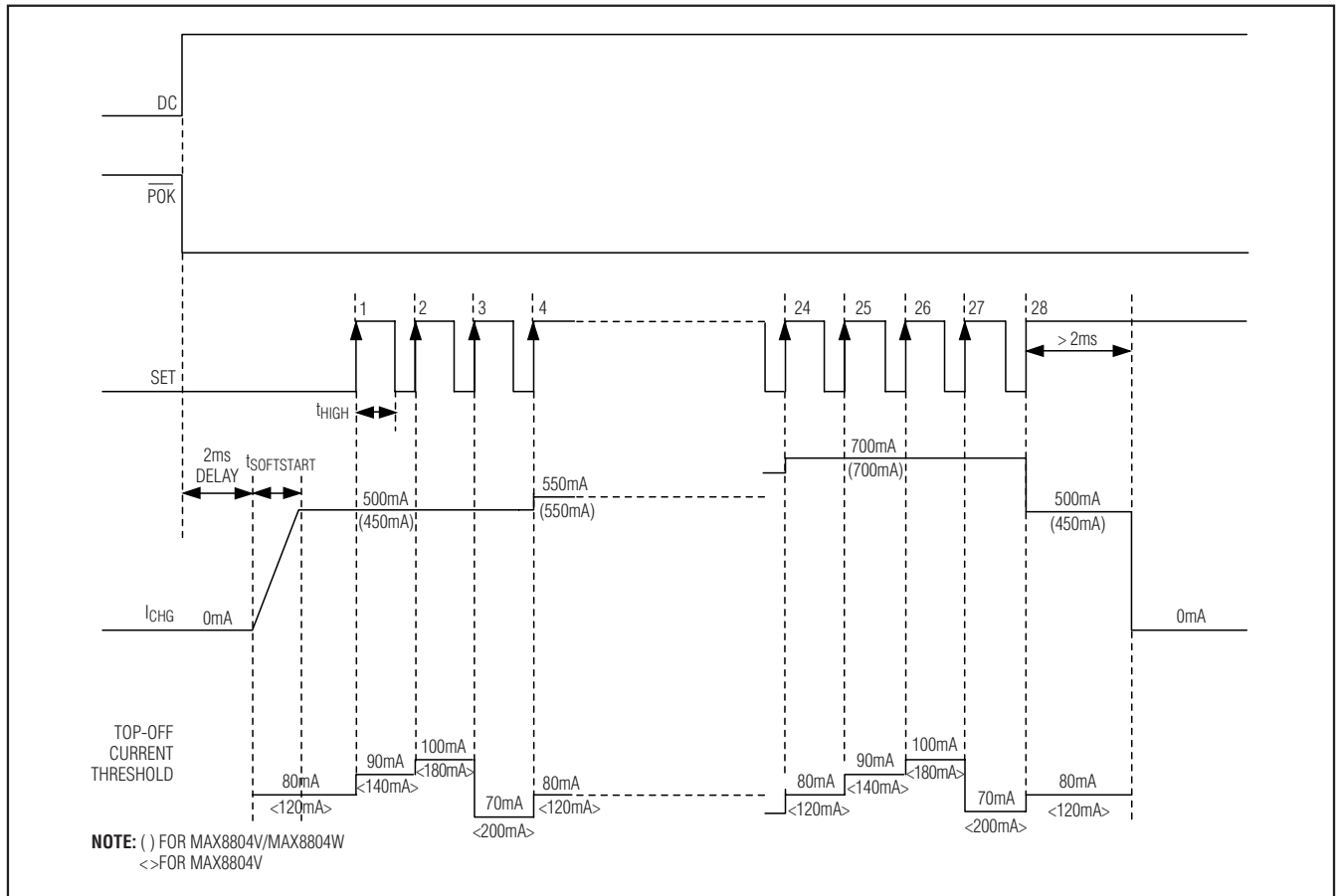

Figure 3. DC Charging Current and Top-Off Threshold Programming

# High-Voltage, Dual-Input, USB/AC Adapter Chargers in 2mm x 3mm TDFN

## USB Charge Mode

Drive SET high to enable USB charging mode when the USB input is valid. Subsequent low pulses with 1μs to 1ms pulse width on SET program the fast charging current from 95mA, 380mA, to 475mA for the MAX8804Y/MAX8804Z and from 380mA, 475mA, to 95mA for the MAX8804V/MAX8804W and then repeat new cycle as shown in Tables 5 and 6. Drive SET low or leave it unconnected longer than 2ms to disable USB charging-control circuitry.

**Table 5. MAX8804Y/MAX8804Z USB Charging Current Programming by Series Pulses**

PULSE NUMBER	DEFAULT	1st	2nd	3rd
I <sub>CHG</sub> (mA)	95	380	475	95
Top-Off Current Threshold (mA)	80	80	80	80

**Table 6. MAX8804V/MAX8804W USB Charging Current Programming by Series Pulses**

PULSE NUMBER	DEFAULT	1st	2nd	3rd
I <sub>CHG</sub> (mA)	380	475	95	380
Top-Off Current Threshold (mA)	80	80	80	80

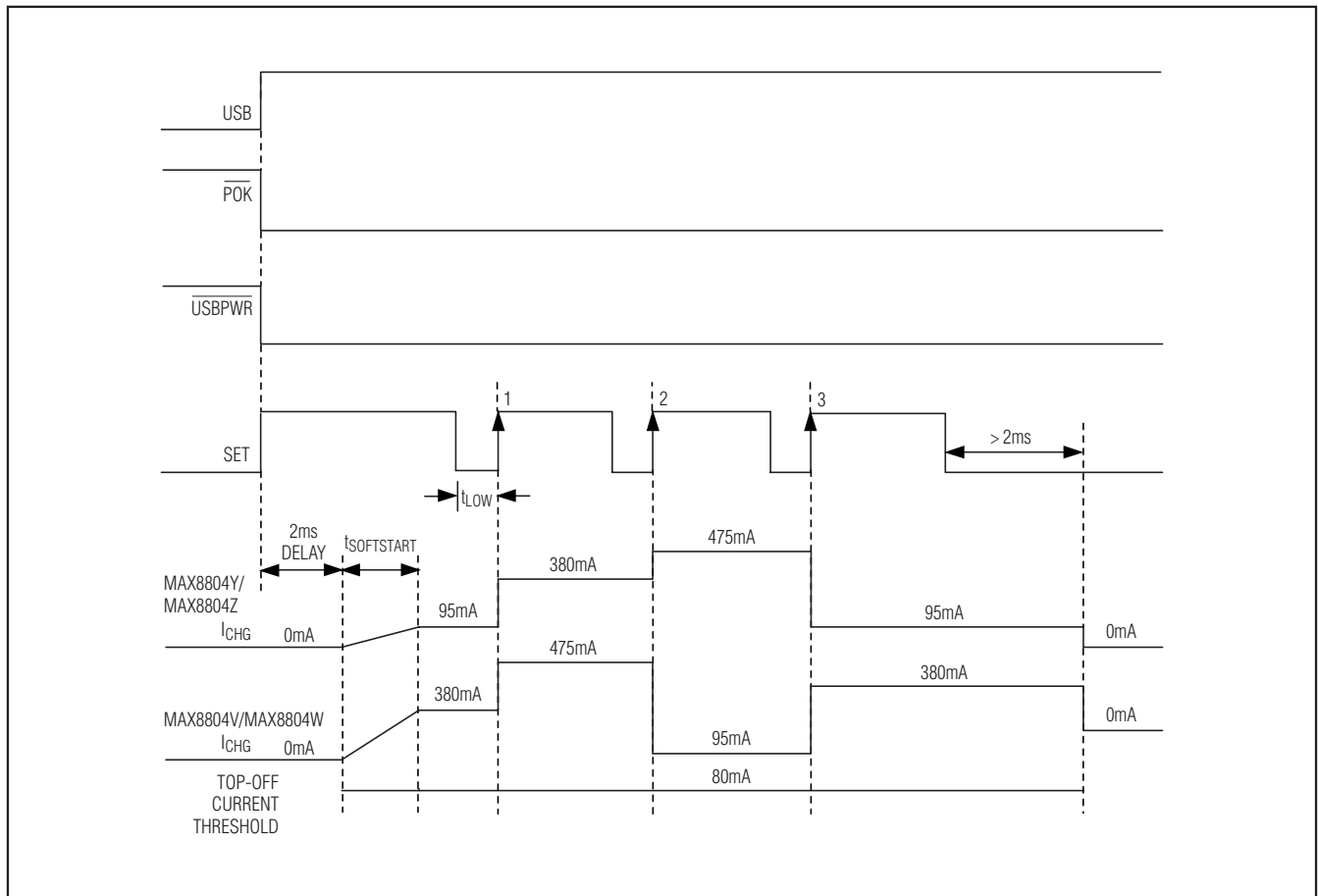

Figure 4. USB Charging Current Programming

# High-Voltage, Dual-Input, USB/AC Adapter Chargers in 2mm x 3mm TDFN

## Soft-Start

The soft-start circuitry activates when entering fast-charge mode. In the MAX8804Y, soft-start is entered directly after being enabled, and the charging current ramps up in 250 $\mu$ s from 0 to 500mA (95mA in USB mode). This reduces the inrush current on the input supply. Note that the MAX8804V/MAX8804W/MAX8804Z has a prequalification state and the charging current ramps up when the prequalification state is complete (VBAT exceeds 2.5V).

## Thermal Regulation Control

The thermal-regulation loop limits the MAX8804V/MAX8804W/MAX8804Y/MAX8804Z die temperature to +105°C by reducing the charge current as necessary. This feature not only protects the ICs from overheating, but also allows a higher charge current at room temperature without risking damage to the system.

## Charging-Status Output ( $\overline{\text{CHG}}$ )

$\overline{\text{CHG}}$  is an open-drain output that indicates charger status.  $\overline{\text{CHG}}$  goes low during charge cycles where the MAX8804V/MAX8804W/MAX8804Y/MAX8804Z are in prequalification or fast-charge mode.  $\overline{\text{CHG}}$  goes high impedance when the charge current reaches the top-off threshold for more than 4ms, indicating charging is done. The  $\overline{\text{CHG}}$  status is latched after the top-off threshold is reached. The latch is reset by toggling the SET input, recycling input power, or increasing the charging current to the top-off threshold plus 57mA (typ).

When the MAX8804V/MAX8804W/MAX8804Y/MAX8804Z are used in conjunction with a microprocessor ( $\mu$ P), connect a pullup resistor between  $\overline{\text{CHG}}$  and the logic I/O voltage to indicate charge status to the  $\mu$ P. Alternatively,  $\overline{\text{CHG}}$  can sink up to 5mA for an LED charge indicator.

## Power-OK Monitor ( $\overline{\text{POK}}$ )

The MAX8804V/MAX8804W/MAX8804Y/MAX8804Z contain an open-drain  $\overline{\text{POK}}$  output that goes low when a valid input source is detected at either DC or USB. A valid input source is one whose voltage is greater than 4.15V and exceeds the battery voltage by 250mV. After a valid input has been established, charging is sustained with inputs as low as 3.5V as long as the input voltage remains above the battery voltage by at least 40mV.  $\overline{\text{POK}}$  status is maintained regardless of SET status.

When the MAX8804V/MAX8804W/MAX8804Y/MAX8804Z are used in conjunction with a  $\mu$ P, connect a pullup resistor between  $\overline{\text{POK}}$  and the logic I/O voltage to indicate power-OK to the  $\mu$ P. Alternatively,  $\overline{\text{POK}}$  can sink up to 5mA for an LED power-OK indicator.

## USB Power Status Output ( $\overline{\text{USBPWR}}$ ) (MAX8804Y/MAX8804Z Only)

$\overline{\text{USBPWR}}$  is internally pulled low when  $V_{\text{USB}} > V_{\text{UVLO}}$  and  $V_{\text{USB}} - V_{\text{BAT}} > 250\text{mV}$ . Otherwise, it is high impedance.  $\overline{\text{USBPWR}}$  indicates the USB input presence regardless of SET status and charger status.

When the MAX8804Y/MAX8804Z are used in conjunction with a  $\mu$ P, connect a pullup resistor between  $\overline{\text{USBPWR}}$  and the logic I/O voltage to indicate USB power status to the  $\mu$ P. Alternatively,  $\overline{\text{USBPWR}}$  can sink up to 5mA for an LED USB power status indicator.

## Battery Pack Detection Input (DETBAT, MAX8804V/MAX8804W Only)

DETBAT is pulled up to an internal 3V supply through a 63k $\Omega$  resistor. Driving DETBAT low or connecting it to GND allows SET to control the charger. When DETBAT is left unconnected, the MAX8804V/MAX8804W enters shutdown.

## Applications Information

### Capacitor Selection

Connect a 2.2 $\mu$ F ceramic capacitor from BAT to GND for proper stability. Connect a 1 $\mu$ F ceramic capacitor from DC to GND. If using the USB input, bypass USB to GND with a 1 $\mu$ F ceramic capacitor. Use a larger input bypass capacitor for high charging currents to reduce supply noise. All capacitors should be X5R dielectric or better. Be aware that some capacitors have large voltage and temperature coefficients and should be avoided.

### Thermal Considerations

The MAX8804V/MAX8804W/MAX8804Y/MAX8804Z are available in a thermally enhanced TDFN package with an exposed paddle. Connect the exposed paddle to a large copper ground plane to provide a thermal contact between the device and the PCB for increased power dissipation. The exposed paddle transfers heat away from the device, allowing the IC to charge the battery with maximum current, while minimizing the die temperature increase.

### Input Sources

The MAX8804V/MAX8804W/MAX8804Y/MAX8804Z operate from well-regulated input sources. The operating input voltage range is 4.15V to 7V. The device survives DC input supply voltages up to 30V and USB input source voltages up to 16V without damage to the IC. If the input voltage is greater than 7.5V (typ), the IC stops charging. An appropriate power supply must provide at least 4.2V plus the voltage drop across the internal pass transistor when sourcing the desired maximum charging current:

MAX8804V/MAX8804W/MAX8804Y/MAX8804Z

# High-Voltage, Dual-Input, USB/AC Adapter Chargers in 2mm x 3mm TDFN

$$V_{IN(MIN)} > 4.2V + I_{CHARGE(MAX)} \times R_{ON}$$

where  $R_{ON}$  is the input-to-BAT resistance (typically  $0.55\Omega$  for DC or  $0.65\Omega$  for USB). Failure to meet this requirement results in an incomplete charge or increased charge time.

## Application Circuits

### Stand-Alone Li+ Charger

The MAX8804V/MAX8804W/MAX8804Y/MAX8804Z provide a complete Li+ charging solution. The *Typical Application Circuit* shows the MAX8804V/MAX8804W/MAX8804Y/MAX8804Z as a stand-alone Li+ battery charger. The LED indicates when either fast-charge or prequalification has begun. When the battery is fully charged, the LED turns off.

### Microprocessor-Interfaced Li+ Charger

Figure 5 shows the MAX8804V/MAX8804W/MAX8804Y/MAX8804Z as a  $\mu P$ -interfaced Li+ battery charger. The  $\mu P$  drives SET to enable/disable DC/USB mode charging. CHG can be used to detect the charge status of a battery.

### Layout and Bypassing

Connect the input capacitors as close as possible to the IC. Provide a large copper GND plane to allow the exposed paddle to sink heat away from the IC. Connect the battery to BAT as close as possible to the IC to provide accurate battery voltage sensing. Make all high-current traces short and wide to minimize voltage drops. A sample layout is available in the MAX8804Z evaluation kit to speed designs.

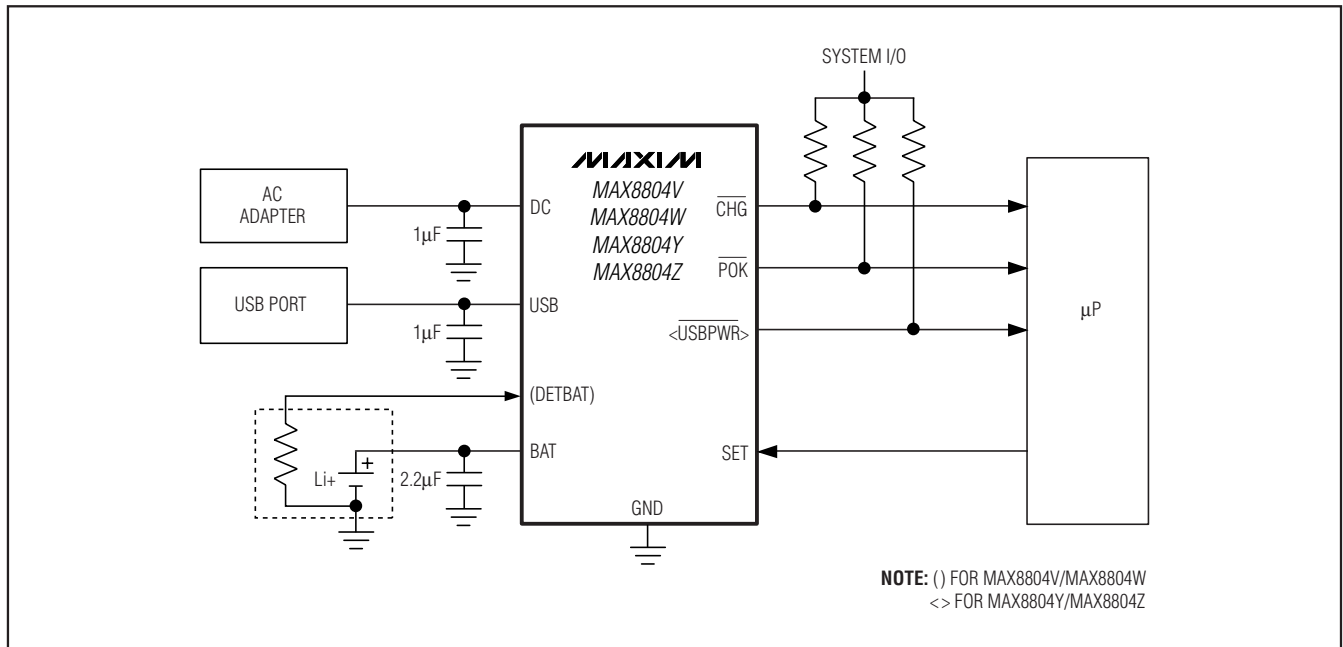
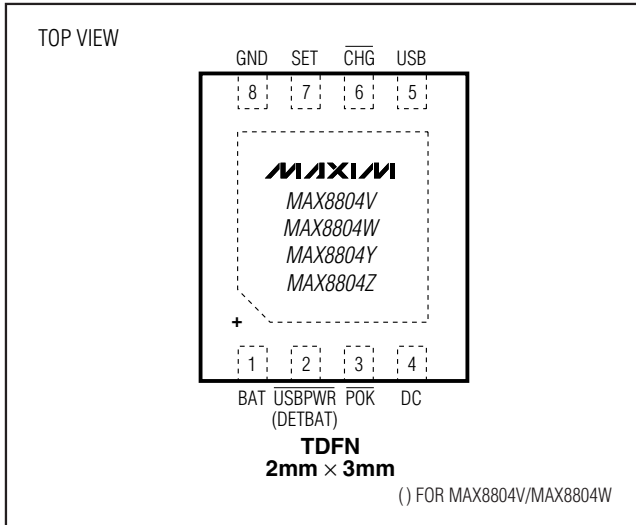

Figure 5. Microprocessor-Interfaced Li+ Charger with the MAX8804V/MAX8804W/MAX8804Y/MAX8804Z

# High-Voltage, Dual-Input, USB/AC Adapter Chargers in 2mm x 3mm TDFN

## Pin Configuration



## Chip Information

PROCESS: BiCMOS

## Package Information

For the latest package outline information, go to [www.maxim-ic.com/packages](http://www.maxim-ic.com/packages).

PACKAGE TYPE	PACKAGE CODE	DOCUMENT NO.
8 TDFN-EP	T823+1	<a href="#">21-0174</a>

MAX8804V/MAX8804W/MAX8804Y/MAX8804Z

# **High-Voltage, Dual-Input, USB/AC Adapter Chargers in 2mm x 3mm TDFN**

## **Revision History**

<b>REVISION NUMBER</b>	<b>REVISION DATE</b>	<b>DESCRIPTION</b>	<b>PAGES CHANGED</b>
0	4/07	Initial release.	—
1	10/07	Added MAX8804W and Battery Pack Detection feature.	1–16
2	4/08	Added MAX8804V and updated <i>DC Charge Mode</i> section.	1–15

Maxim cannot assume responsibility for use of any circuitry other than circuitry entirely embodied in a Maxim product. No circuit patent licenses are implied. Maxim reserves the right to change the circuitry and specifications without notice at any time.

16 **Maxim Integrated Products, 120 San Gabriel Drive, Sunnyvale, CA 94086 408-737-7600**

## Looking for pricing, stock, or lifecycle information?

Click below to explore more details on WIN SOURCE:

- ⊖ [View MAX8804YETA+T on WIN SOURCE](#)
- ⊖ [Maxim Integrated Information](#)

## Optimize Your Supply Chain with WIN SOURCE Solutions

- ✓ Global Sourcing Solution
- ✓ Obsolete Management
- ✓ Cost Control Management
- ✓ Shortage Management
- ✓ Alternative Solution
- ✓ Excess Inventory Management