



**THE DATASHEET OF  
MAX7060ATG/V+T**



# MAX7060

## 280MHz to 450MHz Programmable ASK/FSK Transmitter

### General Description

The MAX7060 frequency and power-programmable ASK/FSK transmitter operates at 280MHz to 450MHz frequencies. This device incorporates a fully integrated fractional-N synthesizer, which allows the user to set the RF operating frequency to a large fraction of the 280MHz to 450MHz frequency range with a single crystal. For example, the MAX7060 can be tuned from 285MHz to 420MHz with a 15MHz crystal. The RF output power is user-controlled between +14dBm and -14dBm, with a 5V supply or with battery voltages as low as 3.2V. At the minimum specified battery voltage of 2.1V, the RF output power-control range is between +10dBm and -14dBm. To maintain a good output power match across a broad range of frequencies, the MAX7060 also contains a programmable matching capacitor connected in parallel with the power amplifier (PA) output.

ASK modulation is accomplished by switching the PA on and off, so excellent modulation (on/off) ratios are achieved. ASK amplitude shaping is available to reduce the width of the transmission spectrum. FSK modulation is accomplished by changing the coefficients of the high-resolution fractional-N synthesizer, so FSK deviation is extremely accurate. Data rates up to 50kbps Manchester coded for ASK and 70kbps Manchester coded for FSK can be maintained while still satisfying regulatory emission-bandwidth standards. The full set of configuration functions are handled by an on-chip serial peripheral interface (SPI). There is also a manual mode where a limited number of settings can be made directly through selected pins.

The startup time is very short, and data can be transmitted 250 $\mu$ s after the enable command. The MAX7060 operates from a 2.1V to 3.6V supply, or internal regulators can be used for supply voltages between 4.5V and 5.5V. The standby current in the 3V mode is 400nA at room temperature, and can be reduced to 5nA using the low-power shutdown (LSHDN) pin.

The MAX7060 is available in a 24-pin (4mm x 4mm) thin QFN package and is specified for the automotive temperature range from -40°C to +125°C.

### Features

- ◆ **Fully Integrated, Fast Fractional-N PLL**  
280MHz to 450MHz RF Frequency  
Frequency Range 100% Tested at +125°C  
< 250 $\mu$ s Startup Time  
Adjustable FSK Mark and Space Frequencies  
Ultra-Clean FSK Modulation  
50kbps Manchester Data Rate ASK  
70kbps Manchester Data Rate FSK
- ◆ **Programmable Power Amplifier**  
+14dBm Tx Power with 5V Supply  
+10dBm Tx Power at 2.1V Supply  
28dB Power-Control Range in 1dB Steps
- ◆ **Tunable PA Matching Capacitor**
- ◆ **Control Through SPI or Manual Settings**
- ◆ **Low Shutdown Current for 2.1V to 3.6V Supply**  
400nA Standby Current, Power-On-Reset (POR) Active  
5nA Shutdown Current, POR Inactive
- ◆ **Supply Flexibility**  
2.1V to 3.6V Single-Supply Operation or  
4.5V to 5.5V Supply Operation with Internal Regulators
- ◆ **24-Pin (4mm x 4mm) TQFN Package**
- ◆ **FCC Part 15, ETSI EN 300 220 Compliant\***

\*ETSI compliance up to +6dBm EIRP.

### Applications

Garage-Door Openers  
Remote Controls  
Home and Industrial Automation  
Sensor Networks  
Security Systems

### Ordering Information

PART	TEMP RANGE	PIN-PACKAGE
MAX7060ATG+	-40°C to +125°C	24 TQFN-EP*
MAX7060ATG/V+	-40°C to +125°C	24 TQFN-EP*

+Denotes a lead(Pb)-free/RoHS-compliant package.

/V denotes an automotive qualified part.

\*EP = Exposed pad.

# MAX7060

## 280MHz to 450MHz Programmable ASK/FSK Transmitter

### ABSOLUTE MAXIMUM RATINGS

GPOVDD, VDD5 to GND.....-0.3V to +6.0V  
 DVDD, PAVDD, and AVDD to GND.....-0.3V to +4.0V  
 ENABLE, SCLK\_PWR0, SDI\_PWR1, DIN,  
 CS\_DEV, LSHDN, FREQ0, FREQ1, FREQ2, GPO1,  
 and GPO2\_MOD to GND.....-0.3V to (VDD5 + 0.3V)  
 PAOUT, ROUT,  
 and PAVOUT to GND ..... -0.3V to (VPAVDD + 0.3V)  
 XTAL1 and XTAL2 to GND.....-0.3V to (VAVDD + 0.3V)

Continuous Power Dissipation (TA = +70°C)  
 24-Pin Thin QFN  
 (derate 20.8mW/°C above +70°C)..... 1666.7mW  
 Operating Temperature Range.....-40°C to +125°C  
 Storage Temperature Range.....-60°C to +150°C  
 Lead Temperature (soldering, 10s) .....+300°C  
 Soldering Temperature (reflow) .....+260°C

Stresses beyond those listed under "Absolute Maximum Ratings" may cause permanent damage to the device. These are stress ratings only, and functional operation of the device at these or any other conditions beyond those indicated in the operational sections of the specifications is not implied. Exposure to absolute maximum rating conditions for extended periods may affect device reliability.

### DC ELECTRICAL CHARACTERISTICS (5V OPERATION)

(Typical Application Circuit, 50Ω system impedance, tuned for 315MHz to 434MHz operation. VDD5 = VGPOVDD = 4.5V to 5.5V, fRF = 280MHz to 450MHz, fXTAL = 15MHz to 16MHz, TA = -40°C to +125°C, unless otherwise noted. Typical values are at VDD5 = VGPOVDD = +5V, TA = +25°C, PA matched for optimum output power, unless otherwise noted. All min and max values are 100% tested at TA = +125°C and guaranteed by design and characterization over temperature, unless otherwise noted.)

PARAMETER	SYMBOL	CONDITIONS	MIN	TYP	MAX	UNITS
Supply Voltage	VDD		4.5	5	5.5	V
Regulated Analog Supply Voltage	AVDD			3.2		V
Active Supply Current	IDD	PLL on, PA off	fRF = 315MHz	4.7	6.0	mA
			fRF = 433.92MHz	5.3	6.9	
		PLL on, PA on, data at 50% duty cycle (ASK), +10dBm (PApwr = 0x19) output power (Notes 1, 2)	fRF = 315MHz	12.5		
			fRF = 433.92MHz	14.2		
		PLL on, PA on, data at 100% duty cycle, +10dBm (PApwr = 0x19) output power (Note 1)	fRF = 315MHz	19	26	
			fRF = 433.92MHz	25	31.6	
PLL on, PA on, data at 100% duty cycle, max (PApwr = 0x1E) output power (Note 1)	fRF = 315MHz	28				
	fRF = 433.92MHz	34				
Standby Current	ISTDBY	VENABLE < VIL, VLSHDN < VIL	TA = +25°C	1.1		µA
			TA = +85°C	1.3		
			TA = +125°C	3.8	6.1	
<b>DIGITAL I/O</b>						
Input High Threshold	VIH		0.9 x VDvDD			V
Input Low Threshold	VIL			0.1 x VDvDD		V

# MAX7060

## 280MHz to 450MHz Programmable ASK/FSK Transmitter

### DC ELECTRICAL CHARACTERISTICS (5V OPERATION) (continued)

(Typical Application Circuit, 50Ω system impedance, tuned for 315MHz to 434MHz operation. V<sub>DD5</sub> = V<sub>GPOVDD</sub> = 4.5V to 5.5V, f<sub>RF</sub> = 280MHz to 450MHz, f<sub>X<sub>TAL</sub></sub> = 15MHz to 16MHz, T<sub>A</sub> = -40°C to +125°C, unless otherwise noted. Typical values are at V<sub>DD5</sub> = V<sub>GPOVDD</sub> = +5V, T<sub>A</sub> = +25°C, PA matched for optimum output power, unless otherwise noted. All min and max values are 100% tested at T<sub>A</sub> = +125°C and guaranteed by design and characterization over temperature, unless otherwise noted.)

PARAMETER	SYMBOL	CONDITIONS	MIN	TYP	MAX	UNITS
Input Pulldown Sink Current	I <sub>IH</sub>			6		μA
Input Pullup Source Current	I <sub>IL</sub>			5		μA
Output-Voltage High	V <sub>OH</sub>	I <sub>SINK</sub> = 100μA (GPO1 and GPO2_MOD, gp1bst bit = 0)		V <sub>GPOVDD</sub> - 0.10		V
		I <sub>SINK</sub> = 200μA (GPO1), boost = on (gp1bst bit = 1)		V <sub>GPOVDD</sub> - 0.14		
Output-Voltage Low	V <sub>OL</sub>	I <sub>SOURCE</sub> = 100μA (GPO1 and GPO2_MOD, gp1bst bit = 0)		0.10		V
		I <sub>SOURCE</sub> = 200μA (GPO1), boost = on (gp1bst bit = 1)		0.14		

### DC ELECTRICAL CHARACTERISTICS (3V OPERATION)

(Typical Application Circuit, 50Ω system impedance, tuned for 315MHz to 434MHz operation. V<sub>DD5</sub> = V<sub>GPOVDD</sub> = V<sub>AVDD</sub> = V<sub>DVDD</sub> = V<sub>PAVDD</sub> = 2.1V to 3.6V, f<sub>RF</sub> = 280MHz to 450MHz, f<sub>X<sub>TAL</sub></sub> = 15MHz to 16MHz, T<sub>A</sub> = -40°C to +125°C, unless otherwise noted. Typical values are at V<sub>DD5</sub> = V<sub>GPOVDD</sub> = V<sub>AVDD</sub> = V<sub>DVDD</sub> = V<sub>PAVDD</sub> = 2.7V, T<sub>A</sub> = +25°C, PA matched for optimum output power, unless otherwise noted. All min and max values are 100% tested at T<sub>A</sub> = +125°C and guaranteed by design and characterization over temperature, unless otherwise noted.)

PARAMETER	SYMBOL	CONDITIONS		MIN	TYP	MAX	UNITS
Supply Voltage	V <sub>DD</sub>			2.1	2.7	3.6	V
Active Supply Current	I <sub>DD</sub>	PLL on, PA off	f <sub>RF</sub> = 315MHz		4.2	6.2	mA
			f <sub>RF</sub> = 433.92MHz		4.8	7.2	
		PLL on, PA on, data at 50% duty cycle (ASK), +10dBm (PA <sub>pwr</sub> = 0x19) output power (Notes 1, 2)	f <sub>RF</sub> = 315MHz		11		
			f <sub>RF</sub> = 433.92MHz		13		
		PLL on, PA on, data at 100% duty cycle, +10dBm (PA <sub>pwr</sub> = 0x19) output power (Note 1)	f <sub>RF</sub> = 315MHz		17.2	27	
			f <sub>RF</sub> = 433.92MHz		22	31.6	
Standby Current	I <sub>STDBY</sub>	V <sub>ENABLE</sub> < V <sub>IL</sub> , V <sub>LSDN</sub> < V <sub>IL</sub>	T <sub>A</sub> = +25°C		0.4	μA	
			T <sub>A</sub> = +85°C		0.5		
			T <sub>A</sub> = +125°C		2.5		6.0
Shutdown Current	I <sub>SHDN</sub>	V <sub>ENABLE</sub> < V <sub>IL</sub> , V <sub>LSDN</sub> > V <sub>IH</sub>	T <sub>A</sub> = +25°C		0.005	μA	
			T <sub>A</sub> = +85°C		0.3		
			T <sub>A</sub> = +125°C		2.6		6.0

# MAX7060

## 280MHz to 450MHz Programmable ASK/FSK Transmitter

### DC ELECTRICAL CHARACTERISTICS (3V OPERATION) (continued)

(Typical Application Circuit, 50Ω system impedance, tuned for 315MHz to 434MHz operation. V<sub>DD5</sub> = V<sub>GPOVDD</sub> = V<sub>AVDD</sub> = V<sub>DVDD</sub> = V<sub>PAVDD</sub> = 2.1V to 3.6V, f<sub>RF</sub> = 280MHz to 450MHz, f<sub>XTAL</sub> = 15MHz to 16MHz, T<sub>A</sub> = -40°C to +125°C, unless otherwise noted. Typical values are at V<sub>DD5</sub> = V<sub>GPOVDD</sub> = V<sub>AVDD</sub> = V<sub>DVDD</sub> = V<sub>PAVDD</sub> = 2.7V, T<sub>A</sub> = +25°C, PA matched for optimum output power, unless otherwise noted. All min and max values are 100% tested at T<sub>A</sub> = +125°C and guaranteed by design and characterization over temperature, unless otherwise noted.)

PARAMETER	SYMBOL	CONDITIONS	MIN	TYP	MAX	UNITS
<b>DIGITAL I/O</b>						
Input High Threshold	V <sub>IH</sub>		0.9 x V <sub>DVDD</sub>			V
Input Low Threshold	V <sub>IL</sub>				0.1 x V <sub>DVDD</sub>	V
Input Pulldown Sink Current	I <sub>IH</sub>		5			μA
Input Pullup Source Current	I <sub>IL</sub>		1.3			μA
Output-Voltage High	V <sub>OH</sub>	ISINK = 100μA (GPO1 and GPO2_MOD, gp1bst bit = 0)	V <sub>GPOVDD</sub> - 0.10			V
		ISINK = 200μA (GPO1), boost = on (gp1bst bit = 1)	V <sub>GPOVDD</sub> - 0.14			
Output-Voltage Low	V <sub>OL</sub>	ISOURCE = 100μA (GPO1 and GPO2_MOD, gp1bst bit = 0)	0.10			V
		ISOURCE = 200μA (GPO1), boost = on (gp1bst bit = 1)	0.14			

### AC ELECTRICAL CHARACTERISTICS (5V OPERATION)

(Typical Application Circuit, 50Ω system impedance, tuned for 315MHz to 434MHz operation, V<sub>DD5</sub> = V<sub>GPOVDD</sub> = 4.5V to 5.5V, f<sub>RF</sub> = 280MHz to 450MHz, f<sub>XTAL</sub> = 15MHz to 16MHz, T<sub>A</sub> = -40°C to +125°C, unless otherwise noted. Typical values are at V<sub>DD5</sub> = V<sub>GPOVDD</sub> = +5V, T<sub>A</sub> = +25°C, PA matched for optimum output power, unless otherwise noted. All min and max values are 100% tested at T<sub>A</sub> = +125°C and guaranteed by design and characterization over temperature, unless otherwise noted.)

PARAMETER	SYMBOL	CONDITIONS	MIN	TYP	MAX	UNITS
<b>GENERAL CHARACTERISTICS</b>						
Frequency Range			280		450	MHz
Power-On Time	t <sub>ON</sub>	ENABLE low-to-high transition, frequency settled to within 50kHz of the desired carrier (includes time for V <sub>PAVOUT</sub> to settle)	130			μs
		ENABLE low-to-high transition, frequency settled to within 5kHz of the desired carrier (includes time for V <sub>PAVOUT</sub> to settle)	185			
Maximum Data Rate (PAPwr = 0x1E)		ASK mode (no shaping)	Manchester encoded	50		kbps
			Nonreturn to zero	100		
		FSK mode	Manchester encoded	70		
			Nonreturn to zero	140		

# MAX7060

## 280MHz to 450MHz Programmable ASK/FSK Transmitter

### AC ELECTRICAL CHARACTERISTICS (5V OPERATION) (continued)

(Typical Application Circuit, 50Ω system impedance, tuned for 315MHz to 434MHz operation, V<sub>DD5</sub> = V<sub>GPOVDD</sub> = 4.5V to 5.5V, f<sub>RF</sub> = 280MHz to 450MHz, f<sub>X TAL</sub> = 15MHz to 16MHz, T<sub>A</sub> = -40°C to +125°C, unless otherwise noted. Typical values are at V<sub>DD5</sub> = V<sub>GPOVDD</sub> = +5V, T<sub>A</sub> = +25°C, PA matched for optimum output power, unless otherwise noted. All min and max values are 100% tested at T<sub>A</sub> = +125°C and guaranteed by design and characterization over temperature, unless otherwise noted.)

PARAMETER	SYMBOL	CONDITIONS	MIN	TYP	MAX	UNITS
Carrier-Frequency Switching Time		Time from end of SPI write or change of FREQ0, FREQ1, or FREQ2 pins, to frequency settled to within 5kHz of desired carrier		60		μs
<b>PLL</b>						
VCO Gain	K <sub>VCO</sub>			340		MHz/V
PLL Phase Noise		f <sub>RF</sub> = 315MHz	10kHz offset	-78		dBc/Hz
			1MHz offset	-97		
		f <sub>RF</sub> = 433.92MHz	10kHz offset	-74		
			1MHz offset	-97		
Loop Bandwidth			300		kHz	
Reference Frequency Input Level				500		mV <sub>P-P</sub>
Frequency Divider Range			19		28	
Frequency Deviation (FSK)			±2		±100	kHz
<b>CRYSTAL OSCILLATOR</b>						
Crystal Frequency	f <sub>X TAL</sub>			15 to 16		MHz
Crystal Load Capacitance (Note 3)				10		pF
<b>POWER AMPLIFIER</b>						
Output Transmit Power (Note 1)	P <sub>OUT</sub>	Maximum output transmit power: P <sub>Apwr</sub> = 0x1E		+14.5		dBm
		Minimum output transmit power: P <sub>Apwr</sub> = 0x00		-14		
Power-Control Step Size				0.95		dB
Modulation Depth (Note 1)				70		dB
Maximum Carrier Harmonics (Note 1)				-24		dBc
Reference Spur				-42		dBc
PAOUT Capacitor Tuning Range				0 to 7.75		pF

# MAX7060

## 280MHz to 450MHz Programmable ASK/FSK Transmitter

### AC ELECTRICAL CHARACTERISTICS (3V OPERATION)

(Typical Application Circuit, 50Ω system impedance, tuned for 315MHz to 434MHz operation.  $V_{DD5} = V_{GPOVDD} = V_{AVDD} = V_{DVDD} = V_{PAVDD} = 2.1V$  to  $3.6V$ ,  $f_{RF} = 280MHz$  to  $450MHz$ ,  $f_{XTAL} = 15MHz$  to  $16MHz$ ,  $T_A = -40^{\circ}C$  to  $+125^{\circ}C$ , unless otherwise noted. Typical values are at  $V_{DD5} = V_{GPOVDD} = V_{AVDD} = V_{DVDD} = V_{PAVDD} = 2.7V$ ,  $T_A = +25^{\circ}C$ , PA matched for optimum output power, unless otherwise noted. All min and max values are 100% tested at  $T_A = +125^{\circ}C$  and guaranteed by design and characterization over temperature, unless otherwise noted.)

PARAMETER	SYMBOL	CONDITIONS		MIN	TYP	MAX	UNITS
<b>GENERAL CHARACTERISTICS</b>							
Frequency Range				280		450	MHz
Power-On Time	$t_{ON}$	ENABLE low-to-high transition, frequency settled to within 50kHz of the desired carrier (includes time for $V_{PAVOUT}$ to settle)			120		$\mu s$
		ENABLE low-to-high transition, frequency settled to within 5kHz of the desired carrier (includes time for $V_{PAVOUT}$ to settle)			200		
Maximum Data Rate ( $PA_{pwr} = 0x19$ )		ASK mode (no shaping)	Manchester encoded		50		kbps
			Nonreturn to zero		100		
		FSK mode	Manchester encoded		70		
			Nonreturn to zero		140		
Carrier-Frequency Switching Time		Time from end of SPI write or change of $FREQ0$ , $FREQ1$ , or $FREQ2$ pins, to frequency settled to within 5kHz of desired carrier			60		$\mu s$
<b>PLL</b>							
VCO Gain	$K_{VCO}$				340		MHz/V
PLL Phase Noise		$f_{RF} = 315MHz$	10kHz offset		-78		dBc/Hz
			1MHz offset		-97		
		$f_{RF} = 433.92MHz$	10kHz offset		-74		
			1MHz offset		-97		
Loop Bandwidth					300		kHz
Reference Frequency Input Level					500		mV <sub>P-P</sub>
Frequency Divider Range				19		28	
<b>CRYSTAL OSCILLATOR</b>							
Frequency Deviation (FSK)				$\pm 2$		$\pm 100$	kHz
Crystal Frequency	$f_{XTAL}$				15 to 16		MHz
Frequency Pulling by Power Supply					4		ppm/V
Crystal Load Capacitance (Note 3)					10		pF
<b>POWER AMPLIFIER</b>							
Output Transmit Power (Note 1)	$P_{OUT}$	$V_{PAVDD} = 2.1V$ , $PA_{pwr} = 0x1E$			+10		dBm
		$V_{PAVDD} = 3.6V$ , $PA_{pwr} = 0x1E$			+15		
		$PA_{pwr} = 0x00$			-14.5		
Power-Control Step Size					0.95		dB
Modulation Depth (Note 1)					70		dB

# MAX7060

## 280MHz to 450MHz Programmable ASK/FSK Transmitter

### AC ELECTRICAL CHARACTERISTICS (3V OPERATION) (continued)

(Typical Application Circuit, 50Ω system impedance, tuned for 315MHz to 434MHz operation. V<sub>DD5</sub> = V<sub>GPOVDD</sub> = V<sub>AVDD</sub> = V<sub>DVDD</sub> = V<sub>PAVDD</sub> = 2.1V to 3.6V, f<sub>RF</sub> = 280MHz to 450MHz, f<sub>XTAL</sub> = 15MHz to 16MHz, T<sub>A</sub> = -40°C to +125°C, unless otherwise noted. Typical values are at V<sub>DD5</sub> = V<sub>GPOVDD</sub> = V<sub>AVDD</sub> = V<sub>DVDD</sub> = V<sub>PAVDD</sub> = 2.7V, T<sub>A</sub> = +25°C, PA matched for optimum output power, unless otherwise noted. All min and max values are 100% tested at T<sub>A</sub> = +125°C and guaranteed by design and characterization over temperature, unless otherwise noted.)

PARAMETER	SYMBOL	CONDITIONS	MIN	TYP	MAX	UNITS
Maximum Carrier Harmonics (Note 1)				-24		dBc
Reference Spur				-43		dBc
PAOUT Capacitor Tuning Range				0 to 7.75		pF

### SERIAL PERIPHERAL INTERFACE (SPI) TIMING CHARACTERISTICS

(SPI timing characteristics are valid for both 3V and 5V modes. SPI timing is production tested at worst-case temperature and supply with a clock frequency of 3MHz.)

PARAMETER	SYMBOL	CONDITIONS	MIN	TYP	MAX	UNITS
Minimum SCLK_PWR0 Low to Falling-Edge of $\overline{\text{CS}}_{\text{DEV}}$ Setup Time	t <sub>SC</sub>			30		ns
Minimum $\overline{\text{CS}}_{\text{DEV}}$ Low to Rising Edge of SCLK_PWR0 Setup Time	t <sub>CSS</sub>			15		ns
Minimum SCLK_PWR0 Low to Rising Edge of $\overline{\text{CS}}_{\text{DEV}}$ Setup Time	t <sub>HCS</sub>			60		ns
Minimum SCLK_PWR0 Low After Rising Edge of $\overline{\text{CS}}_{\text{DEV}}$ Hold Time	t <sub>HS</sub>			15		ns
Minimum Data Valid to SCLK_PWR0 Rising-Edge Setup Time	t <sub>DS</sub>			30		ns
Minimum Data Valid to SCLK_PWR0 Rising-Edge Hold Time	t <sub>DH</sub>			15		ns
Minimum SCLK_PWR0 High Pulse Width	t <sub>CH</sub>			120		ns
Minimum SCLK_PWR0 Low Pulse Width	t <sub>CL</sub>			120		ns
Minimum $\overline{\text{CS}}_{\text{DEV}}$ High Pulse Width	t <sub>CSH</sub>			120		ns
Maximum Transition Time from Falling-Edge of $\overline{\text{CS}}_{\text{DEV}}$ to Valid GPO2_MOD	t <sub>CSG</sub>	C <sub>L</sub> = 10pF load capacitance from GPO2_MOD to ground		400		ns
Maximum Transition Time from Falling Edge of SCLK_PWR0 to Valid GPO2_MOD	t <sub>CG</sub>	C <sub>L</sub> = 10pF load capacitance from GPO2_MOD to ground		400		ns

**Note 1:** Supply current and output power are greatly dependent on board layout and PAOUT match.

**Note 2:** 50% duty cycle at 10kHz ASK data (Manchester coded).

**Note 3:** Dependent on PCB trace capacitance.

# MAX7060

## 280MHz to 450MHz Programmable ASK/FSK Transmitter

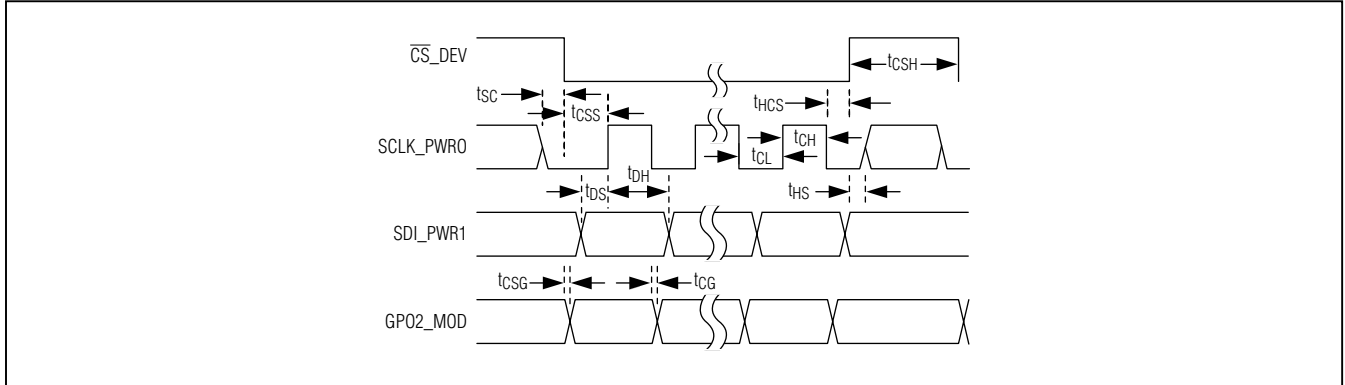
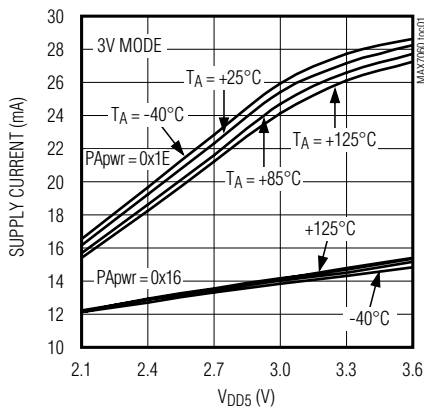

Figure 1. SPI Timing Diagram

### Typical Operating Characteristics

(Typical Application Circuit, 50Ω system impedance,  $V_{DD5} = V_{GPOVDD} = V_{AVDD} = V_{DVDD} = V_{PAVDD} = 2.1V$  to  $3.6V$ ,  $f_{RF} = 280MHz$  to  $450MHz$ ,  $f_{XTAL} = 16MHz$ ,  $T_A = -40^{\circ}C$  to  $+125^{\circ}C$ , unless otherwise noted. Typical values are at  $V_{DD5} = V_{GPOVDD} = V_{AVDD} = V_{DVDD} = V_{PAVDD} = 2.7V$ ,  $T_A = +25^{\circ}C$ , PA matched for optimum output power, unless otherwise noted. Supply current and output power are greatly dependent on board layout and PAOUT match.)

**SUPPLY CURRENT vs. SUPPLY VOLTAGE**  
( $f_{RF} = 315MHz$ , PA ON)



**SUPPLY CURRENT vs. SUPPLY VOLTAGE**  
( $f_{RF} = 315MHz$ , PA ON)

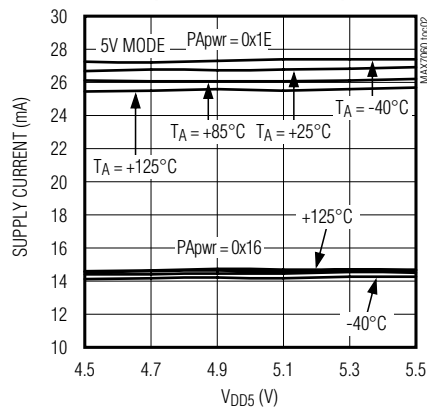

**SUPPLY CURRENT vs. SUPPLY VOLTAGE**  
( $f_{RF} = 315MHz$ , PA OFF)

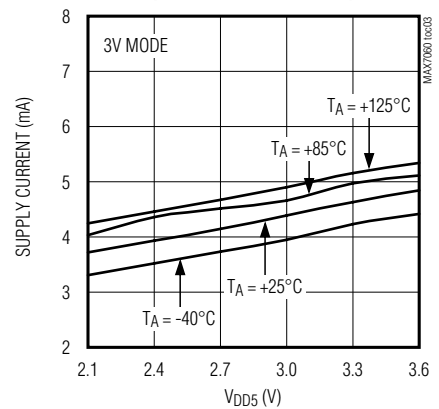

**SUPPLY CURRENT vs. SUPPLY VOLTAGE**  
( $f_{RF} = 433.92MHz$ , PA ON)

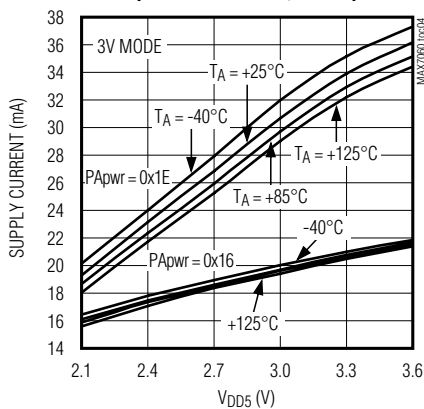

**SUPPLY CURRENT vs. SUPPLY VOLTAGE**  
( $f_{RF} = 433.92MHz$ , PA ON)

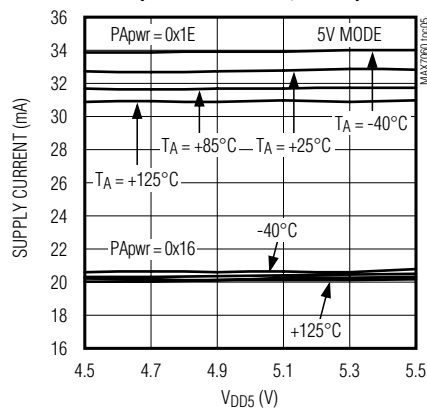

**SUPPLY CURRENT vs. SUPPLY VOLTAGE**  
( $f_{RF} = 433.92MHz$ , PA OFF)

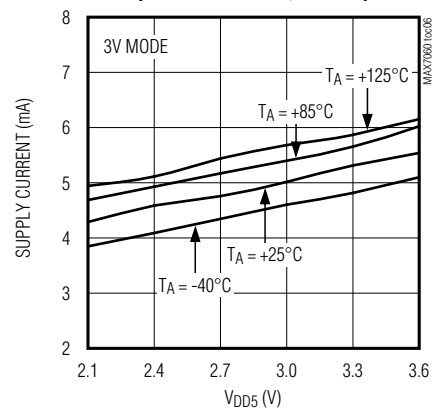

# MAX7060

## 280MHz to 450MHz Programmable ASK/FSK Transmitter

### Typical Operating Characteristics (continued)

(Typical Application Circuit, 50Ω system impedance,  $V_{DD5} = V_{GPOVDD} = V_{AVDD} = V_{DVDD} = V_{PAVDD} = 2.1V$  to  $3.6V$ ,  $f_{RF} = 280MHz$  to  $450MHz$ ,  $f_{XTAL} = 16MHz$ ,  $T_A = -40^\circ C$  to  $+125^\circ C$ , unless otherwise noted. Typical values are at  $V_{DD5} = V_{GPOVDD} = V_{AVDD} = V_{DVDD} = V_{PAVDD} = 2.7V$ ,  $T_A = +25^\circ C$ , PA matched for optimum output power, unless otherwise noted. Supply current and output power are greatly dependent on board layout and PAOUT match.)

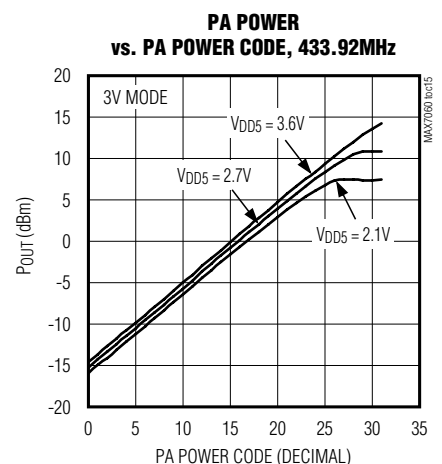
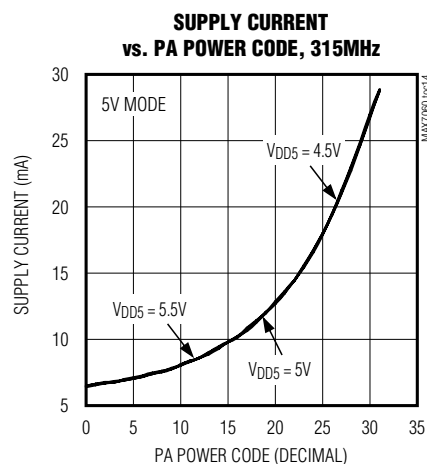
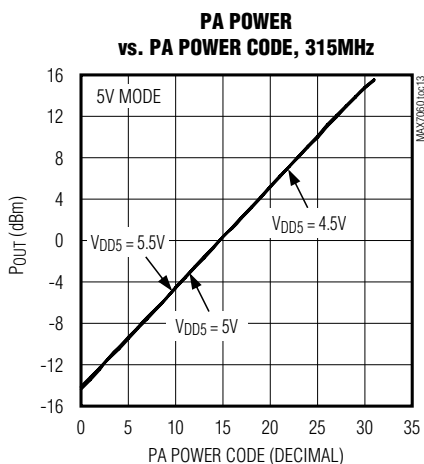
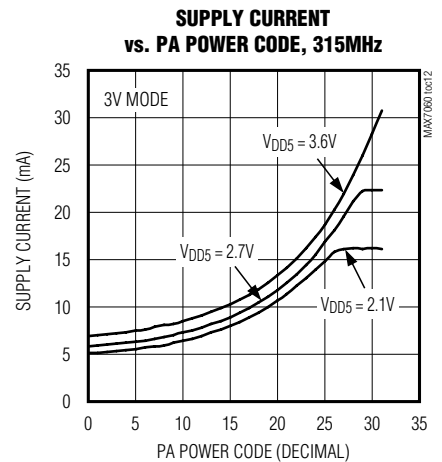
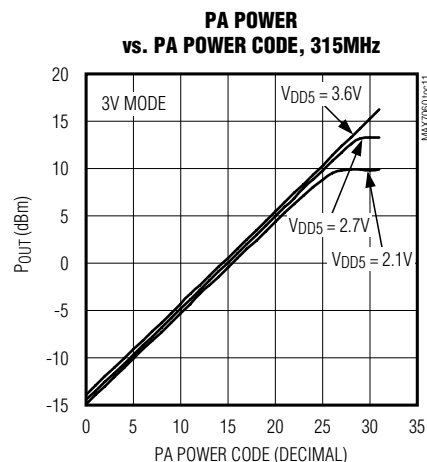
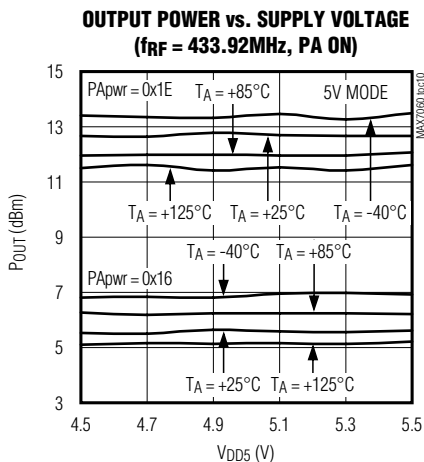
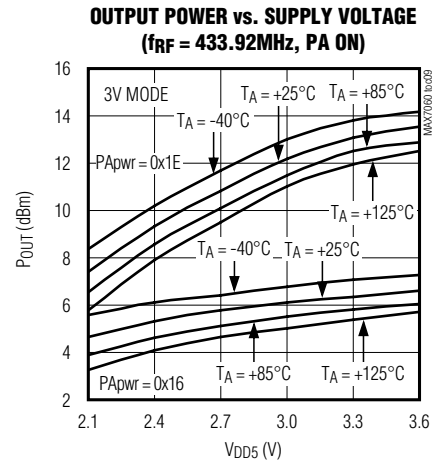
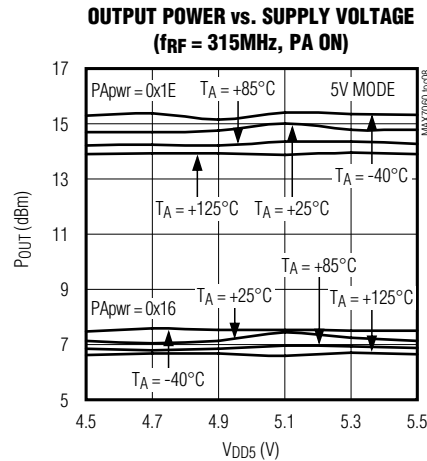
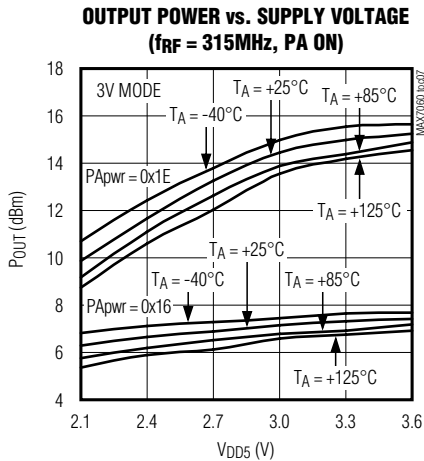

# MAX7060

## 280MHz to 450MHz Programmable ASK/FSK Transmitter

### Typical Operating Characteristics (continued)

(Typical Application Circuit, 50Ω system impedance,  $V_{DD5} = V_{GPOVDD} = V_{AVDD} = V_{DVDD} = V_{PAVDD} = 2.1V$  to  $3.6V$ ,  $f_{RF} = 280MHz$  to  $450MHz$ ,  $f_{XTAL} = 16MHz$ ,  $T_A = -40^{\circ}C$  to  $+125^{\circ}C$ , unless otherwise noted. Typical values are at  $V_{DD5} = V_{GPOVDD} = V_{AVDD} = V_{DVDD} = V_{PAVDD} = 2.7V$ ,  $T_A = +25^{\circ}C$ , PA matched for optimum output power, unless otherwise noted. Supply current and output power are greatly dependent on board layout and PAOUT match.)

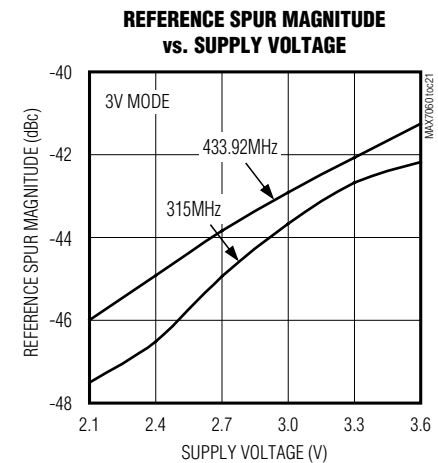
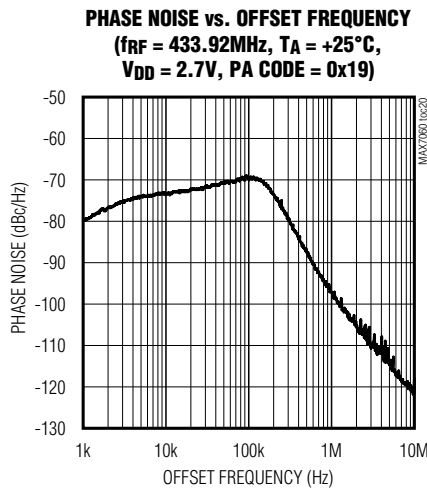
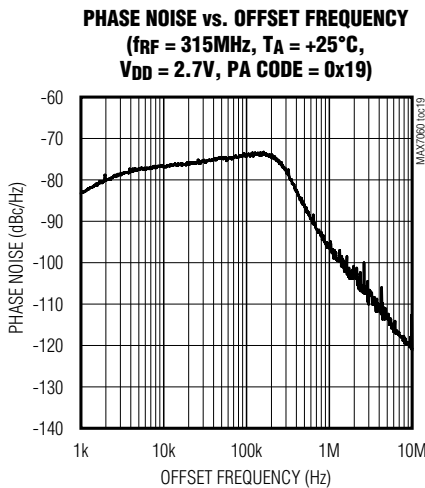
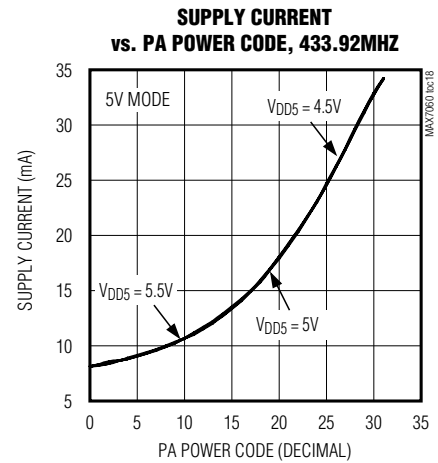
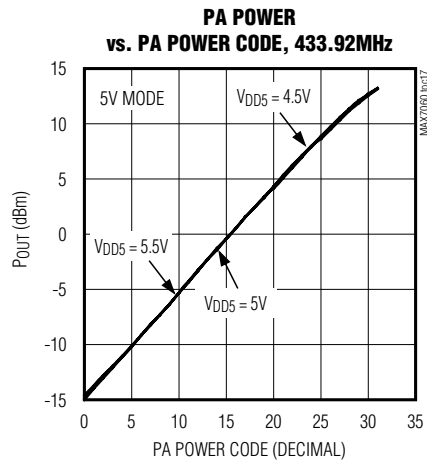
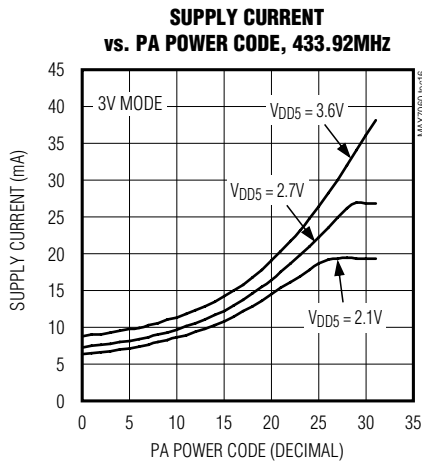

# MAX7060

## 280MHz to 450MHz Programmable ASK/FSK Transmitter

### Typical Operating Characteristics (continued)

(Typical Application Circuit, 50Ω system impedance,  $V_{DD5} = V_{GPOVDD} = V_{AVDD} = V_{DVDD} = V_{PAVDD} = 2.1V$  to  $3.6V$ ,  $f_{RF} = 280MHz$  to  $450MHz$ ,  $f_{XTAL} = 16MHz$ ,  $T_A = -40^{\circ}C$  to  $+125^{\circ}C$ , unless otherwise noted. Typical values are at  $V_{DD5} = V_{GPOVDD} = V_{AVDD} = V_{DVDD} = V_{PAVDD} = 2.7V$ ,  $T_A = +25^{\circ}C$ , PA matched for optimum output power, unless otherwise noted. Supply current and output power are greatly dependent on board layout and PAOUT match.)

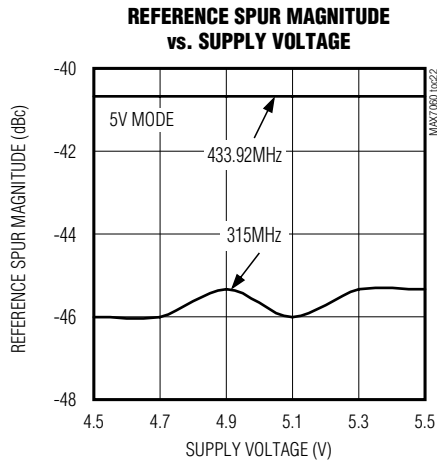

**FSK SPECTRUM ( $f_{RF} = 315MHz$ ,  $+25^{\circ}C$ ,  $V_{DD} = 2.7V$ , PA CODE = 0x19  $\pm 50kHz$  DEVIATION, 4kHz SQUARE WAVE ON DIN)**

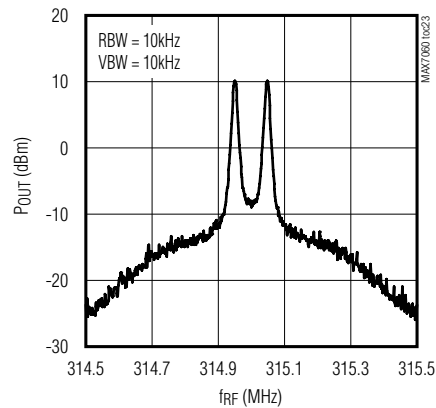

### Pin Configuration/Functional Diagram

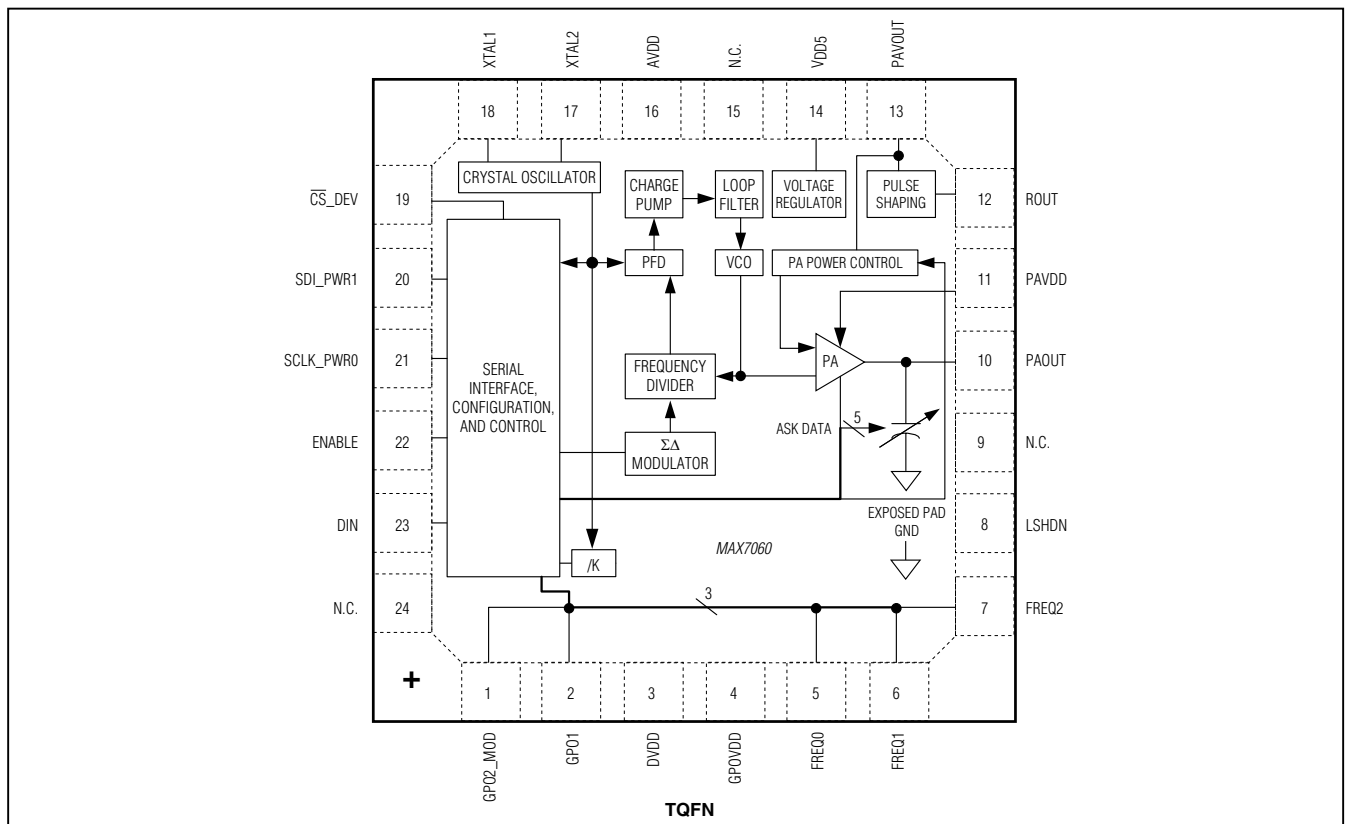

# MAX7060

## 280MHz to 450MHz Programmable ASK/FSK Transmitter

### Pin Description

PIN	NAME	FUNCTION
1	GPO2_MOD	(SPI Mode/Manual Mode) Digital Input/Output. GPO2 output in SPI mode. Acts as an SPI data output when $\overline{CS\_DEV}$ is low. ASK (0)/FSK (1) modulation select input in manual mode. This pin is internally pulled down in manual mode.
2	GPO1	General-Purpose Output 1. In SPI mode, this pin can output many internal status signals. In manual mode, this pin outputs the synthesizer lock-detect (lockdet) signal.
3	DVDD	Digital-Supply Voltage Input. Bypass to GND with a 0.01 $\mu$ F capacitor as close as possible to the pin.
4	GPOVDD	Power-Supply Voltage Input for GPOs and ESD-Protection Devices. Bypass to GND with a 0.01 $\mu$ F capacitor as close as possible to the pin.
5	FREQ0	Frequency-Select Pin 0 in Manual Mode. Internally pulled down. FREQ0 = FREQ1 = FREQ2 = 0 for SPI mode.
6	FREQ1	Frequency-Select Pin 1 in Manual Mode. Internally pulled down. FREQ0 = FREQ1 = FREQ2 = 0 for SPI mode.
7	FREQ2	Frequency-Select Pin 2 in Manual Mode. Internally pulled down. FREQ0 = FREQ1 = FREQ2 = 0 for SPI mode.
8	LSHDN	Low-Power Shutdown Current-Select Digital Input. Turns off internal POR circuit and disables pullup/pulldown currents. Must be driven low for normal operation in 3V mode. Functional only in 3V mode. Connect to GND in 5V mode.
9, 15, 24	N.C.	No Connection. Internally not connected. Leave unconnected.
10	PAOUT	Power Amplifier Output. Requires a pullup inductor to PAVOUT, which can be part of the output-matching network to an antenna.
11	PAVDD	Power Amplifier Predriver Power-Supply Input. Bypass to GND with a 680pF capacitor and a 0.01 $\mu$ F as close as possible to the pin.
12	ROUT	Envelope-Shaping Resistor Connection. See the <i>Typical Application Circuits</i> and the <i>ASK Envelope Shaping</i> sections for details.
13	PAVOUT	Power Amplifier Power-Control Output. Controls the transmitted power. Connect to PA pullup inductor. Bypass to ground with 680pF capacitor.
14	VDD5	Supply Voltage Input. Bypass to ground with 0.01 $\mu$ F and 0.1 $\mu$ F capacitors.
16	AVDD	Analog Supply Voltage and Regulator Output. Bypass to GND with 0.1 $\mu$ F and 0.01 $\mu$ F capacitors as close as possible to the pin.
17	XTAL2	Crystal Input 2. XTAL2 can be driven from an AC-coupled external reference.
18	XTAL1	Crystal Input 1. AC-couple to GND if XTAL2 is driven from an AC-coupled external reference.
19	$\overline{CS\_DEV}$	(SPI Mode/Manual Mode) Serial Peripheral Interface (SPI) Active-Low Chip-Select Input. FSK frequency-deviation input (0 = low deviation, 1 = high deviation) in manual mode. Internally pulled up.
20	SDI_PWR1	(SPI Mode/Manual Mode) SPI Data Input in SPI Mode. Power-control MSB input in manual mode. Internally pulled down.
21	SCLK_PWR0	(SPI Mode/Manual Mode) SPI Clock Input in SPI Mode. Power-control LSB input in manual mode. Internally pulled down.
22	ENABLE	Enable Digital Input. All internal circuits (except the PA in ASK mode) are enabled on the rising edge of ENABLE. Internally pulled down.
23	DIN	Transmit Data Digital Input. Internally pulled down.
—	EP	Exposed Pad. Solder evenly to the board's ground plane for proper operation.

# MAX7060

## 280MHz to 450MHz Programmable ASK/FSK Transmitter

### Detailed Description

The MAX7060 is power and frequency programmable from 280MHz to 450MHz. The MAX7060 has an internal transmit power control that can be programmed over a 28dB power range. The MAX7060 has tuning capacitors at the output of the power amplifier (PA) to ensure high-power efficiency at various programmable frequencies with a single matching network.

The crystal-based architecture of the MAX7060 eliminates many of the common problems with SAW transmitters by providing greater modulation depth, faster frequency settling, tighter tolerance of the transmit frequency, and reduced temperature dependence. In particular, the tighter transmit frequency tolerance means that a superheterodyne receiver with a narrower IF bandwidth (therefore lower noise bandwidth) can be used. The payoff is better overall receiver performance when using a superheterodyne receiver such as the MAX1473, MAX1471, MAX7033, MAX7034, MAX7036, and MAX7042.

The MAX7060 can be configured in either SPI or manual mode, where the transmitter can easily be configured without the need of an SPI interface.

In the 3V operation, the MAX7060 can be put in a low-power shutdown mode by pulling ENABLE low and LSHDN high. In this mode, all the blocks are shut down including power-on reset (POR). All the MAX7060 registers must be reprogrammed after LSHDN is asserted high. In the 5V operation, the low-power shutdown mode is not available, and LSHDN should be connected to GND.

### Frequency Programming

The MAX7060 is a crystal-referenced phased-locked-loop (PLL) VHF/UHF transmitter that transmits data over a wide frequency range. The internal VCO can be tuned from 280MHz to 450MHz and controlled by a single crystal to cover up to a 1.47:1 carrier-frequency range. The transmit frequency is set by the crystal frequency and the programmable divider in the PLL; the programmable PLL divide ratios can be set anywhere from 19 to 28, which means that with a crystal frequency of 15MHz, the output is 285MHz to 420MHz. With a crystal frequency of 16MHz, the output is 304MHz to 448MHz.

The MAX7060 has an internal variable capacitor connected across the PA output. This capacitor can be programmed to maintain high-efficiency transmission at any frequency within a 1.47 to 1 (28/19) tuning range. This

means that it is possible to change the frequency and retune the antenna to the new frequency in a very short time. The combination of rapid antenna-tuning ability with rapid synthesizer tuning makes the MAX7060 a true frequency-agile transmitter. The tuning capacitor has a nominal resolution of 0.25pF, from 0 to 7.75pF.

The MAX7060 supports data rates up to 100kbps NRZ in ASK mode and 140kbps NRZ in FSK mode. In FSK mode, the frequency deviation corresponding to bit 1 and bit 0 can be set as low as  $\pm 2$ kHz, and as high as  $\pm 100$ kHz. The frequency deviation is fully programmable in SPI mode, and can be selected either as  $\pm 16$ kHz or  $\pm 50$ kHz in manual mode.

### Power Amplifier (PA)

The PA of the MAX7060 is a high-efficiency, open-drain switching-mode amplifier. In a switching-mode amplifier, the gate of the final-stage FET is driven with a very sharp 25% duty-cycle square wave at the transmit frequency. This square wave is derived from the synthesizer circuit. When the matching network is tuned correctly, the output FET resonates the attached tank circuit with a minimum amount of power dissipated in the FET. With a proper output-matching network, the PA can drive a wide range of antenna impedances, which include a small-loop PCB trace and a  $50\Omega$  antenna. The output-matching network suppresses the carrier harmonics and transforms the antenna impedance to an optimal impedance at PAOUT, which is from  $60\Omega$  to  $125\Omega$ . When the output-matching network is properly tuned, the MAX7060 transmits power with a high overall efficiency. The efficiency of the PA itself is approximately 50%.

### Transmitter Power Control

The transmitter power of the MAX7060 can be set in approximately 1dB steps (SPI mode) to produce a maximum output power level of +14dBm with a 5V supply. If a battery is used as the supply, the maximum output power level varies from +15dBm at 3.6V to +10dBm at 2.1V. The minimum power level is -14dBm for both 5V and battery supplies. The maximum transmitter power (and the transmitter current) can be lowered by increasing the load impedance on the PA. Four fixed power levels are available in manual mode.

When a 5V supply is used, the VDD5 and GPOVDD pins are connected to the 5V supply. AVDD is the output of an internal voltage regulator and must be connected externally to DVDD and PAVDD. The PAVOUT pin is connected to the PAOUT pin through a biasing inductor. PAVOUT is not connected to any of the power-supply

# MAX7060

## 280MHz to 450MHz Programmable ASK/FSK Transmitter

pins. Connecting PAVOUT to PAOUT enables Tx power control. In SPI mode, there are 31 power-control settings in approximately 1dB monotonic steps. In manual mode, four power-control settings are available.

### ASK Envelope Shaping

The MAX7060 has two types of ASK envelope shaping: digital shaping (SPI mode only) and analog shaping through an internal resistor. Envelope shaping results in a smaller spectral width of the modulated PA output signal.

In digital shaping, the user can choose the final Tx power setting, the power step size in units as small as 1dB, and the step-time interval in units as small as 0.25 $\mu$ s, when a 16MHz crystal is used. This shaping method causes the PA to transmit an envelope that rises linearly in decibels (exponentially in power) with time. Digital shaping is programmed through the SPI.

The analog shaping mode uses an internal envelope-shaping resistor for ASK modulation, which connects between PAVOUT and ROUT. When the ROUT pin (rather than the PAVOUT pin) is connected to the PA pullup inductor, the envelope-shaping resistor slows the turn-on/turn-off time of the PA. The user can choose two turn-on/turn-off times through the SPI. A single turn-on/turn-off time is set internally in manual mode.

It should be noted that, by default, data pulses applied to the DIN pin are internally lengthened by 64 crystal clock cycles (4 $\mu$ s for a 16MHz crystal) to allow time for the analog shaping to occur. For cases in which no analog shaping is desired, the PA pullup inductor must be connected to PAVOUT and the analog shaping bits in the Conf0 register set to either `anshp[1:0] = 00`, which leaves the extra 4 $\mu$ s pulse extension in place, or to `anshp[1:0] = 11`, which removes the extra 4 $\mu$ s and allows transmitted pulses to track the data present at the DIN pin. If digital shaping is used, the PA pullup inductor must be connected to PAVOUT and there is no 4 $\mu$ s pulse extension, regardless of the status of the `anshp[1:0]` bits.

At low data rates, where shaping is not necessary and the 4 $\mu$ s pulse lengthening has minimal impact on duty cycle symmetry, it may be acceptable to use the default configuration of `anshp[1:0] = 00`. For higher data rates, it may be necessary to use `anshp[1:0] = 11`, to avoid duty cycle skew. Another method to remove the pulse lengthening is to apply a minimal amount of digital shaping, by setting `tstep[3:0] = 0001` and selecting `pastep[4:0] = papwr[4:0]`.

### Variable Capacitor

The MAX7060 has an internal set of capacitors that can be switched in and out to present different capacitor values at the PA output. The capacitors are connected from the PA output to ground. This allows changing the tuning network along with the synthesizer divide ratio each time the transmitted frequency changes, making it possible to maintain maximum transmitter power while moving rapidly from one frequency to another.

In SPI mode, the variable capacitor is programmed through a register setting. In manual mode, the capacitor setting is programmed through the DIN pin.

The tuning capacitor has a nominal resolution of 0.25pF, from 0 to 7.75pF.

### Phase-Locked Loop (PLL)

The MAX7060 utilizes a fully integrated fractional-N PLL for its frequency synthesizer. All PLL components, including the loop filter, are included on-chip. Two loop bandwidths can be selected in SPI mode. The synthesizer has 16-bit fractional-N topology (4 bits integer, 12 bits fractional) with a divide ratio that can be set from 19 to 28, allowing the transmit frequency to be adjusted in increments of  $f_{XTAL}/4096$ .

The fractional-N architecture also allows exact FSK frequency deviations to be programmed, completely eliminating the problems associated with generating frequency deviations by crystal oscillator pulling.

FSK deviations as low as  $\pm 2$ kHz and as high as  $\pm 100$ kHz can be set in SPI mode. In manual mode, the user can select between  $\pm 16$ kHz and  $\pm 50$ kHz.

The integer and fractional portions of the PLL divider ratio set the transmit frequency. This is done by loading the divide-ratio registers in SPI mode, or selecting the states of the three frequency-control pins (FREQ2, FREQ1, FREQ0) in manual mode. For ASK modulation, the two 8-bit center-frequency registers (`fce[15:0]`) are loaded with the divide ratio determined by the center frequency and the crystal. For FSK modulation, the two 8-bit high (mark) frequency registers (`fhi[15:0]`) and the two 8-bit low (space) frequency registers (`flo[15:0]`) are loaded. The divide ratios for the `fhi` and `flo` are determined by the center frequency, the frequency deviation, and the crystal frequency. Examples of typical settings for ASK and FSK modulation are given in the *SPI Mode Settings* section.

# MAX7060

## 280MHz to 450MHz Programmable ASK/FSK Transmitter

### Crystal (XTAL) Oscillator

The XTAL oscillator in the MAX7060 is designed to present a capacitance of approximately 6pF between the XTAL1 and XTAL2 pins. In most cases, this corresponds to a 8pF load capacitance applied to the external crystal when typical PCB parasitics are added. It is very important to use a crystal with a load capacitance equal to the capacitance of the MAX7060 crystal oscillator plus PCB parasitics. If a crystal designed to oscillate with a different load capacitance is used, the crystal is pulled away from its stated operating frequency, introducing an error in the reference frequency. A crystal designed to operate at a higher load capacitance than the value specified for the oscillator is always pulled higher in frequency. Adding capacitance to increase the load capacitance on the crystal increases the startup time and can prevent oscillation altogether.

In actuality, the oscillator pulls every crystal. The crystal's natural frequency is really below its specified frequency, but when loaded with the specified load capacitance, the crystal is pulled and oscillates at its specified frequency. This pulling is already accounted for in the specification of the load capacitance.

Additional pulling can be calculated if the electrical parameters of the crystal are known. The frequency pulling is given by:

$$f_p = \frac{C_M}{2} \left( \frac{1}{C_{CASE} + C_{LOAD}} - \frac{1}{C_{CASE} + C_{SPEC}} \right) \times 10^6$$

where:

$f_p$  is the amount the crystal frequency pulled in ppm

$C_M$  is the motional capacitance of the crystal

$C_{CASE}$  is the case capacitance

$C_{SPEC}$  is the specified load capacitance

$C_{LOAD}$  is the actual load capacitance

When the crystal is loaded as specified (i.e.,  $C_{LOAD} = C_{SPEC}$ ), the frequency pulling equals zero.

### General-Purpose Output (GPO)/Clock Outputs

The MAX7060 has two GPO pins in SPI mode (GPO2\_MOD and GPO1) and one GPO in manual mode (GPO1).

The GPO1 pin can serve as a clock for a microprocessor or any other GPO function in SPI mode. In manual mode, this pin outputs the synthesizer lock-detect (lockdet) status, after which the user can send data through the DIN pin.

The GPO2\_MOD pin acts as the SPI data output when the  $\overline{CS\_DEV}$  pin is low, in SPI mode. When  $\overline{CS\_DEV}$  is high, it acts as a GPO that can output various internal signals, such as the synthesizer lock detect (lockdet).

In SPI mode, the output clock that can be routed through GPO1 is a divided version of the crystal frequency. The divide ratio is set through the MAX7060 registers, and the divide settings are 1 (no division), 2, 4, 8, or 16. When driving an output clock through GPO1, the gp1bst bit (register Conf0, address 0x01, bit 6) can be set to 1 to increase GPO1 drive strength. If even more drive capability is required, the user should provide an external buffer.

### Serial Peripheral Interface (SPI)

The MAX7060 utilizes a 4-wire SPI protocol for programming its registers, configuring and controlling the operation of the whole transmitter. For SPI operation, the FREQ2, FREQ1, and FREQ0 pins must be reset to 0.

The following digital I/Os control the operation of the SPI:

$\overline{CS\_DEV}$	Active-low SPI chip select
SDI_PWR1	SPI data Input
SCLK_PWR0	SPI clock
GPO2_MOD	SPI data output

Figure 2 shows the general timing diagram of the SPI protocol.

Any number of 8-bit data bursts (Data 1, Data 2 ... Data n) can be sent within one cycle of the  $\overline{CS\_DEV}$  pin, to allow for burst-write or burst-read operations. The SPI data output signal is routed through the GPO2\_MOD pin when  $\overline{CS\_DEV}$  is low.

# MAX7060

## 280MHz to 450MHz Programmable ASK/FSK Transmitter

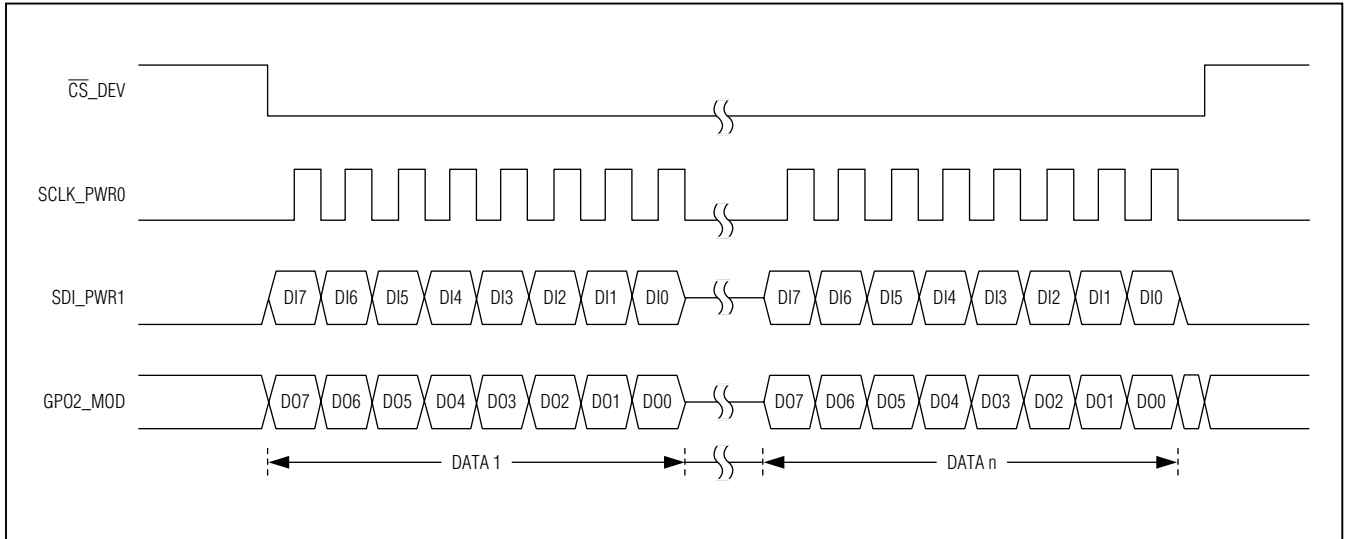

Figure 2. SPI Format

### SPI Commands

The following commands are implemented in the MAX7060:

**Write:** Within the same  $\overline{CS\_DEV}$  cycle, a write command is implemented as follows:

SDI\_PWR1: <0x01> <Initial Address> <Data 1> <Data 2> ... <Data N>

With this command, Data 1 is written to the address given by <Initial Address>, Data 2 is written to <Initial Address + 1>, and so on.

**Read:** Within the same  $\overline{CS\_DEV}$  cycle, a read command is implemented as follows:

SDI\_PWR1: <0x02> <Address 1> <Address 2> <Address 3> ... <Address N> <0x00>

GPO2\_MOD: <0xXX> <0xXX> <Data 1> <Data 2> ... <Data N - 1> <Data N>

With this command, all the registers can be read within the same cycle of  $\overline{CS\_DEV}$ . The addresses can be given in any order.

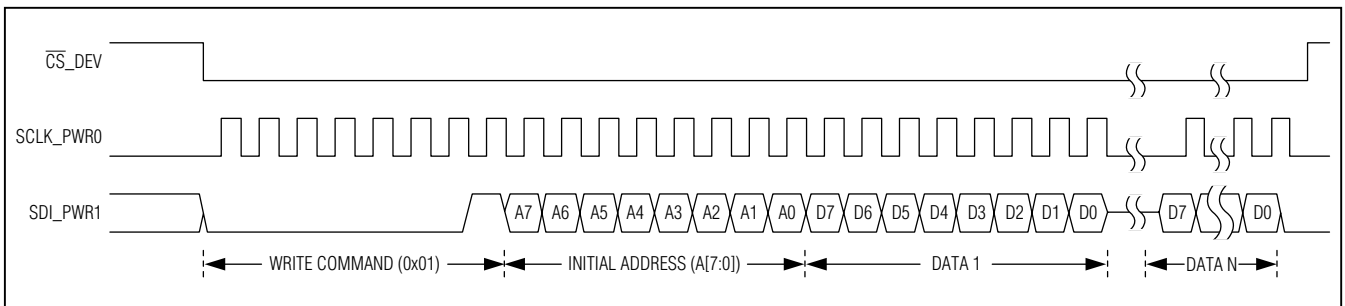

Figure 3. SPI Write Command Format

## 280MHz to 450MHz Programmable ASK/FSK Transmitter

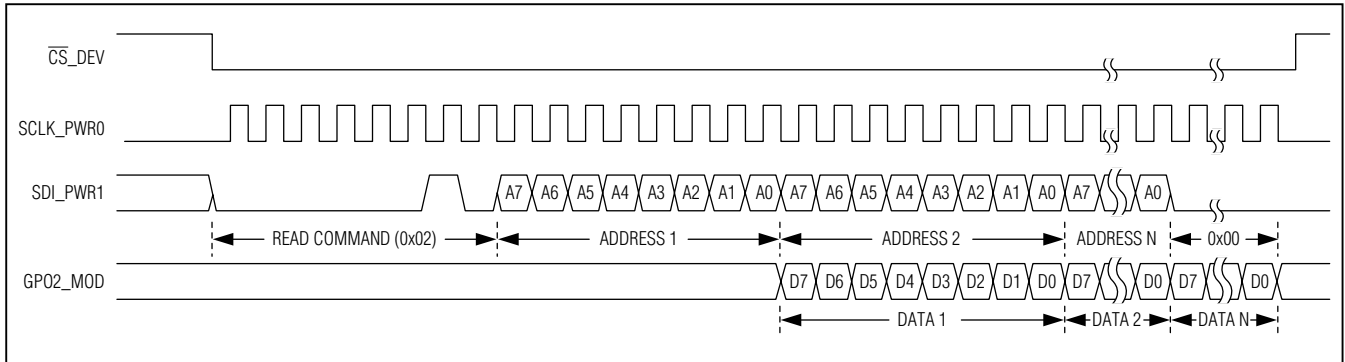
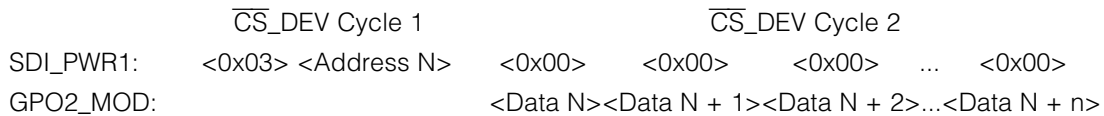

Figure 4. SPI Read Command Format

**Read All:** Within two  $\overline{CS\_DEV}$  cycles, the read-all command is implemented as follows:



**Reset:** An SPI reset command is implemented as follows:

SDI\_PWR1: <0x04>

An internal active-low master reset pulse is generated, from the falling edge of the last SCLK\_PWR0 signal to the falling edge of the following  $\overline{CS\_DEV}$  signal ( $t_{HCS} + t_{CSH}$ ).

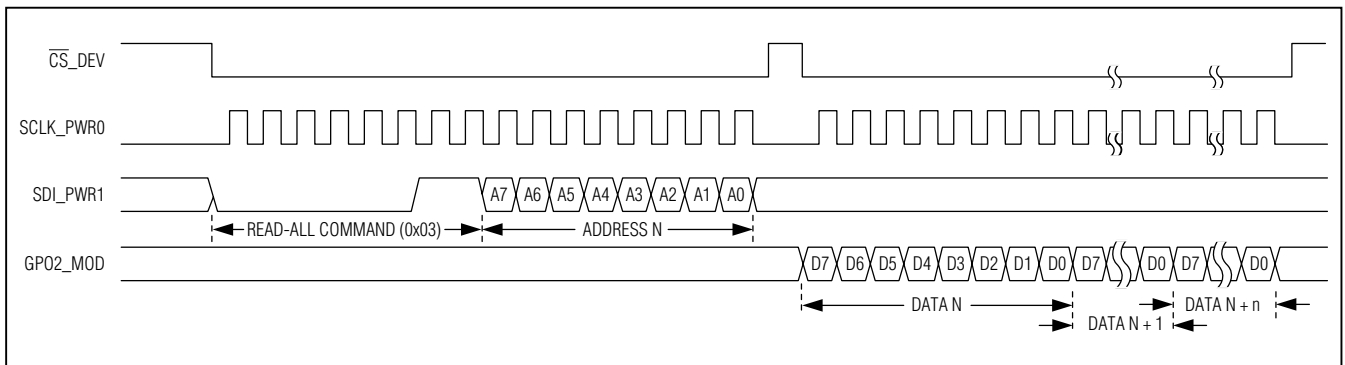

Figure 5. SPI Read-All Command Format

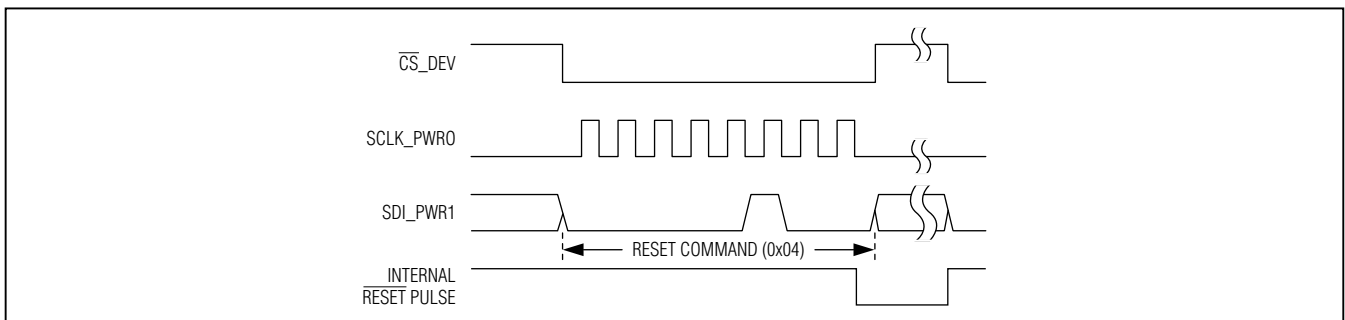

Figure 6. SPI Reset Command Format

# MAX7060

## 280MHz to 450MHz Programmable ASK/FSK Transmitter

### Applications Information

#### SPI Mode Settings

##### ASK Carrier Frequency

When the MAX7060 is in ASK mode, only the carrier frequency needs to be set. To do this, the user calculates the divide ratio based on the carrier frequency and crystal frequency. The example below shows how to determine the correct value to be loaded into the carrier-frequency registers (fce[15:0]).

Due to the nature of the transmit PLL frequency divider, a fixed offset of 16 must be subtracted from the transmit PLL divider ratio for programming the MAX7060's transmit-frequency registers. To determine the value to program the MAX7060's transmit-frequency registers, convert the decimal value of the following equation to the nearest hexadecimal value:

$$\left( \frac{f_{RF}}{f_{XTAL}} - 16 \right) \times 4096 = \text{decimal value to program the transmit-frequency registers}$$

Assume the ASK transmit frequency = 315MHz and  $f_{XTAL} = 16\text{MHz}$ . In this example, the rounded decimal value is 15,104 or 0x3B00. The upper byte (0x3B) is loaded into the FCenter0 register (fce[15:8]) and the lower byte (0x00) is loaded into the FCenter1 register (fce[7:0]).

##### FSK Mark and Space Frequencies

When the MAX7060 is in FSK mode, two frequencies need to be set: the mark (logical 1) frequency and the space (logical 0) frequency. In most cases, the two frequencies are above and below the carrier frequency by the deviation frequency. Therefore, the user needs to calculate the divide ratio for both frequencies and load them into four registers. The procedure for calculating the register settings is the same as it is for calculating the carrier frequency. The example below shows how to determine the register settings for the mark and space frequencies when the frequency deviation is  $\pm 50\text{kHz}$  (100kHz between mark and space).

Assume that, for an FSK transmitter centered at 433.92MHz, the mark frequency is 433.97MHz, the space frequency is 433.87MHz, and the crystal frequency is 16MHz. In this example, the rounded decimal value for the mark frequency is 45,560 or 0xB1F8. For the space frequency, the rounded decimal value is 45,535 or 0xB1DE. The mark setting is loaded into the FHigh0 and FHigh1 registers (fhi[15:0]), and the space setting is loaded into the FLow0 and FLow1 registers (flo[15:0]).

##### Transmit Power Settings (5V Supply)

The output power level is set by entering a 5-bit value into the PApwr register (papwr[4:0]). The highest setting (30dec or 0x1E) corresponds to the highest transmitted power level. Each step is slightly less than 1dB (approximately 0.95dB), with the lowest setting producing a transmitted power 28dB lower than the highest. The highest transmitted power depends on the load presented to the PA output. A 50 $\Omega$  or 60 $\Omega$  load produces an output power level of +14dBm to +15dBm when the highest papwr[4:0] setting (0x1E) is applied. Increasing the load resistance reduces the output power level. Reducing the setting by one step reduces the power by approximately 1dB, and the minimum transmitted power is still about 28dB below the maximum. For example, if the load resistance is increased to the point where the output power for the maximum setting (0x1E) is +10dBm, then the minimum setting (0x00) produces an output power of about -18dBm.

##### Transmit Power Settings (3V Supply)

The output power level in 3V operation is set the same way as in 5V operation, but the variation in the 3V supply (the specified range is 2.1V to 3.6V) affects the maximum power that can be transmitted. If the supply is 3.6V, then the maximum papwr[4:0] setting (0x1E) still produces a +14dBm to +15dBm transmitted power level. As the supply voltage decreases, the transmitted power at the highest settings is compressed, so that the top setting and an increasing number of the lower settings produce the same transmitted power, which is lower than the +14dBm to +15dBm achieved with a 3.6V supply. For example, a 2.7V supply produces a maximum transmitter power of +12dBm to +13dBm, and the PApwr register settings from 0x1B to 0x1E (27dec to 30dec) produce the same transmitter power. Below this compressed range, the power settings give the same power levels that they would give with a 5V supply. At the lowest supply level of 2.1V, the maximum setting produces a maximum transmitter power of +10dBm, and the PApwr register settings from 0x19 to 0x1E (25dec to 30dec) produce the same transmitter power. The effect of a lower supply voltage reduces the maximum power and the adjustment range. The power at the lowest setting remains unchanged.

The transmitted power using a 3V supply can be set higher than the levels described in the paragraph above by connecting PAOUT directly to PAVDD and disconnecting (leave open) the PAVOUT pin. The tradeoff of this connection is that there is no transmit power adjustment.

## 280MHz to 450MHz Programmable ASK/FSK Transmitter

### ASK Amplitude Shaping

At data rates higher than 30kbps Manchester (60kbps NRZ), it may be necessary to shape the ASK transmitter pulses to reduce the occupied bandwidth of the transmitted signal to comply with government regulations (FCC in the U.S., ETSI in Europe). There is no shaping of the FSK modulation. The MAX7060 has two forms of amplitude shaping: digital and analog.

### Digital Amplitude Shaping

The digital shaping feature allows the user to choose a linear stairstep function to increase and decrease the power when the PA is turned on and off for an ASK bit interval. There are three registers that control the digital amplitude shaping settings. The first setting is the final power of the PA when the pulse reaches its maximum (PAPwr register). The second setting is the amplitude change, in decibels, for each step, which is the vertical axis of the stairstep (PAstep register). The third setting is the time interval of each step, which is the horizontal axis of the stairstep (Tstep register). The final power setting (decimal 0 to 30 in increments of 1dB) is entered in the PAPwr register. The amplitude step (decimal 0 to 30 in increments of 1dB) is entered in the PAstep register. The time interval (decimal 0 to 60/f<sub>XTAL</sub> in increments of 4/f<sub>XTAL</sub>) is entered in the Tstep register. For example, to shape an 80kbps NRZ data stream (12.5µs bit interval), the user might choose a maximum power level of 0x1E (30dec), an amplitude step of 5dB, and a time interval of 0.5µs assuming a crystal frequency of 16MHz. This would produce an ASK pulse that ramps up in 3µs, levels off for 9.5µs, and ramps down in 3µs. Because the amplitude steps are in decibels, the shape of the pulse rise and fall is exponential on a linear display (an oscilloscope, for instance). Because most ASK receivers use a logarithmic amplitude detector, the demodulated pulse

has a linear ramp shape. The digital shaping is disabled when the Tstep register is 0x00.

If no shaping of any kind is used (digital or analog), the PA pullup inductor must be connected to PAVOUT and the analog shaping bits in the Conf0 register must also be set to either anshp[1:0] = 00 or to anshp[1:0] = 11, as described in the *ASK Envelope Shaping* section.

### Analog Amplitude Shaping

To use the analog shaping feature, the user must connect the bias inductor to the ROUT pin instead of directly to the PAVOUT pin. This places a MOS resistor between PAVOUT and ROUT, which slows down the application of the PAVOUT voltage to the drain of the PA FET when the PA is turned on. There are two settings in the anshp[1:0] bits in the Conf0 register for the rate at which the pulse ramps up: anshp[1:0] = 10 is approximately 1.5µs and anshp[1:0] = 01 is approximately 3µs. The anshp[1:0] = 11 setting turns analog shaping off and removes the 4µs pulse extension, while the anshp[1:0] = 00 setting opens the connection between PAVOUT and ROUT.

### Tuning Capacitor Settings

The internal variable shunt capacitor, which can be used to match the PA to the antenna with changing transmitter frequency, is controlled by setting the 5-bit cap variable in the registers. This allows for 32 levels of shunt capacitance control. Since the control of these 5 bits is independent of the other settings, any capacitance value can be chosen at any frequency, making it possible to maintain maximum transmitter efficiency while moving rapidly from one frequency to another. The internal tuning capacitor adds 0 to 7.75pF to the PA output in 0.25pF steps. The PA output capacitance at the minimum cap setting is approximately 4.5pF.

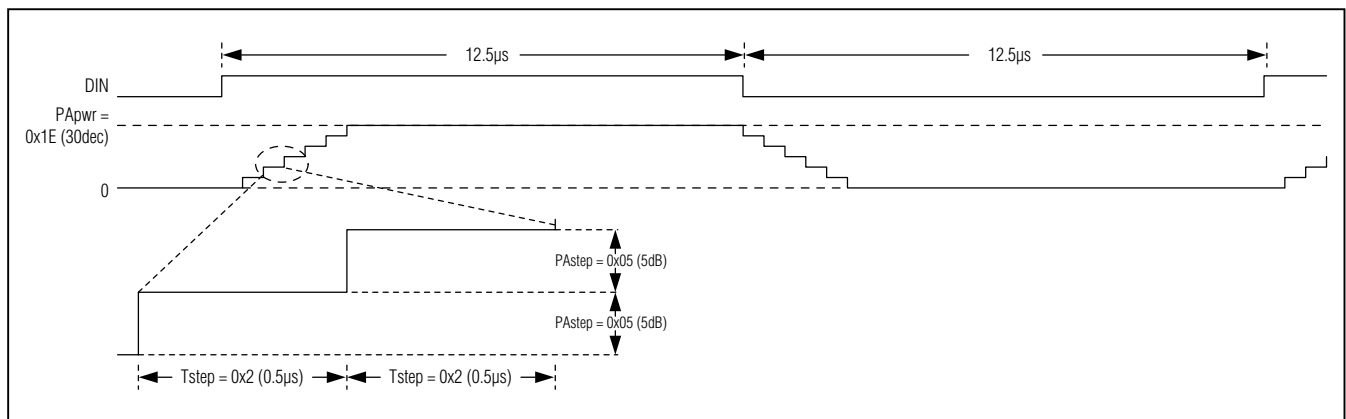

Figure 7. Digital Amplitude Shaping Timing Diagram

# MAX7060

## 280MHz to 450MHz Programmable ASK/FSK Transmitter

### Register Details

The following tables provide information on the MAX7060 registers.

**Table 1. Register Summary**

REGISTER	ADDRESS	DESCRIPTION
Ident	0x00	Read-only register used for identification purpose. The content of this register is always 0xA6.
Conf0	0x01	Configuration 0 register. Controls the GPO1 boost mode, PLL bandwidth, analog shaping, crystal clock output, and the modulation mode (ASK/FSK).
Conf1	0x02	Configuration 1 register. Controls the clock output frequency divider and the capacitance at the PA output.
Conf2	0x03	Configuration 2 register. Controls the emulation mode.
IOConf0	0x04	IO configuration 0 register. Selects the status register bus for SPI operation.
IOConf1	0x05	IO configuration 1 register. Selects the outputs of GPO1 and GPO2_MOD pins.
Tstep	0x06	Digital shaping time step register. Controls the time step in the digital shaping.
PAstep	0x07	Digital shaping power step register. Controls the power step in the digital shaping.
PAPwr	0x08	Final power register. Controls the final output power.
FHigh0	0x09	High-frequency 0 register (upper byte). Sets the high frequency in FSK transmission.
FHigh1	0x0A	High-frequency 1 register (lower byte). Sets the high frequency in FSK transmission.
FCenter0	0x0B	Center-frequency 0 register (upper byte). Sets the carrier frequency in ASK transmission.
FCenter1	0x0C	Center-frequency 1 register (lower byte). Sets the carrier frequency in ASK transmission.
FLow0	0x0D	Low-frequency 0 register (upper byte). Sets the low frequency in FSK transmission.
FLow1	0x0E	Low-frequency 1 register (lower byte). Sets the low frequency in FSK transmission.
FLoad	0x0F	Frequency-load register. Performs the frequency-load function.
EnableReg	0x10	Enable register. Register equivalent of ENABLE pin.
DataReg	0x11	Datrain register. Register equivalent of DIN pin.
Status	0x12	Status register

**Table 2. Configuration Registers**

REGISTER	ADDRESS	DATA								MODE
		BIT 7	BIT 6	BIT 5	BIT 4	BIT 3	BIT 2	BIT 1	BIT 0	
Ident	0x00	1	0	1	0	0	1	1	0	R
Conf0	0x01	—	gp1bst	pllbw	anshp_1	anshp_0	clksby	clkout	mode	R/W
Conf1	0x02	ckdiv_2	ckdiv_1	ckdiv_0	cap_4	cap_3	cap_2	cap_1	cap_0	R/W
Conf2	0x03	fixed	fxmode	fxpwr_1	fxpwr_0	fxhdev	fxfrq_2	fxfrq_1	fxfrq_0	R/W
IOConf0	0x04	—	—	—	—	—	tmux_2	tmux_1	tmux_0	R/W
IOConf1	0x05	—	gp2s_2	gp2s_1	gp2s_0	—	gp1s_2	gp1s_1	gp1s_0	R/W
Tstep	0x06	—	—	—	—	tstep_3	tstep_2	tstep_1	tstep_0	R/W
PAstep	0x07	—	—	—	pastp_4	pastp_3	pastp_2	pastp_1	pastp_0	R/W
PAPwr	0x08	—	—	—	papwr_4	papwr_3	papwr_2	papwr_1	papwr_0	R/W
FHigh0	0x09	fhi_15	fhi_14	fhi_13	fhi_12	fhi_11	fhi_10	fhi_9	fhi_8	R/W
FHigh1	0x0A	fhi_7	fhi_6	fhi_5	fhi_4	fhi_3	fhi_2	fhi_1	fhi_0	R/W
FCenter0	0x0B	fce_15	fce_14	fce_13	fce_12	fce_11	fce_10	fce_9	fce_8	R/W
FCenter1	0x0C	fce_7	fce_6	fce_5	fce_4	fce_3	fce_2	fce_1	fce_0	R/W

## 280MHz to 450MHz Programmable ASK/FSK Transmitter

**Table 2. Configuration Registers (continued)**

REGISTER	ADDRESS	DATA								
		BIT 7	BIT 6	BIT 5	BIT 4	BIT 3	BIT 2	BIT 1	BIT 0	MODE
FLow0	0x0D	flo_15	flo_14	flo_13	flo_12	flo_11	flo_10	flo_9	flo_8	R/W
FLow1	0x0E	flo_7	flo_6	flo_5	flo_4	flo_3	flo_2	flo_1	flo_0	R/W
FLoad	0x0F	—	—	—	—	—	—	—	hop	R/W
EnableReg	0x10	—	—	—	—	—	—	—	enable	R/W
DataReg	0x11	—	—	—	—	—	—	—	datain	R/W
Status	0x12	status_7	status_6	status_5	status_4	status_3	status_2	status_1	status_0	R

**Table 3. Identification (Ident) Register (Address: 0x00)**

BIT	NAME	FUNCTION
7:0	ident	Read-only register used for identification purpose. The content of this register is always 0xA6.

**Table 4. Configuration 0 (Conf0) Register (Address: 0x01)**

BIT	NAME	FUNCTION
6	gp1bst	0 = Normal GPO1 output driver 1 = Extended driving capability on GPO1
5	pllbw	PLL bandwidth setting, low (0) = 300kHz or high (1) = 600kHz; 300kHz is recommended for fractional-N and 600kHz for fixed-N (ASK mode only)
4:3	anshp[1:0]	<b>Control time constants of the analog shaping (bias inductor connected to the ROUT pin)</b> <b>anshp[1:0] Rise/fall time</b> 00 ROUT open-circuited, 4μs pulse extension present 01 nominal 3.0μs rise/fall time 10 nominal 1.5μs rise/fall time 11 no analog shaping, no 4μs pulse extension
2	clksby	Crystal clock output enable (1) while part is in standby mode
1	clkout	Crystal clock output enable (1) on GPO1 output, gp1s[2:0] = 0x2
0	mode	ASK (0) or FSK (1)

**Table 5. Configuration 1 (Conf1) Register (Address: 0x02)**

BIT	NAME	FUNCTION
7:5	ckdiv[2:0]	3-bit clock output frequency divider
4:0	cap[4:0]	5-bit capacitor setting

**Table 6. Crystal Divide Settings for Clock Output**

ckdiv[2:0]	CRYSTAL FREQUENCY DIVIDED BY
000	1
001	2
010	4
011	8
1XX	16

# MAX7060

## 280MHz to 450MHz Programmable ASK/FSK Transmitter

Table 7. Configuration 2 (Conf2) Register (Address: 0x03)

BIT	NAME	FUNCTION
7	fixed	Enable (1) or disable (0) emulation mode
6	fxmode	FSK (1) or ASK (0)
5:4	fxpwr[1:0]	<b>Output power setting</b> <b>fxpwr[1:0]      dB below P<sub>MAX</sub></b> 00                    0 01                    3 10                    6 11                    10
3	fxhdev	100kHz (1) or 32kHz (0) frequency deviation in FSK
2:0	fxfrq[2:0]	<b>Frequency selection</b> The combinations are same as those in manual mode. When a 16MHz crystal is used, the following frequency values are selected by fxfrq[2:0]. <b>fxfrq[2:0]    Freq (MHz)    Divide Ratio</b> 000            N/A                N/A 001            315.00            19.68750 010            433.62            27.10125 011            390.00            24.37500 100            418.00            26.12500 101            372.00            23.25000 110            345.00            21.56250 111            433.92            27.12000

Table 8. IO Configuration 0 (IOConf0) Register (Address: 0x04)

BIT	NAME	FUNCTION
2:0	tmux[2:0]	Status register output selection bits

## 280MHz to 450MHz Programmable ASK/FSK Transmitter

**Table 9. IO Configuration 1 (IOConf1) Register (Address: 0x05)**

BIT	NAME	FUNCTION				
6:4	gp2s[2:0]	<b>GPO2 output selection</b>				
		<b>CS_DEV</b>	<b>Bit 2</b>	<b>Bit 1</b>	<b>Bit 0</b>	<b>GPO2_MOD</b>
		0	X	X	X	SPI Data Output
		1	0	0	0	lockdet
		1	0	0	1	—
		1	0	1	0	ckout
		1	0	1	1	—
		1	1	0	0	—
		1	1	0	1	nock
2:0	gp1s[2:0]	<b>GPO1 output selection</b>				
		<b>Bit 2</b>	<b>Bit 1</b>	<b>Bit 0</b>	<b>GPO1</b>	
		0	0	0	lockdet	
		0	0	1	—	
		0	1	0	ckout	
		0	1	1	—	
		1	0	0	—	
		1	0	1	nock	
1	1	0	—			
1	1	1	—			

where:

- Reserved signals
- nock No-clock flag (1) if crystal oscillator is disabled, and (0) if clock activity is observed
- ckout Clock output signal, according to programmed dividers (ckdiv[2:0])
- lockdet PLL lock-detect flag

**Table 10. ASK Digital Shaping Time Step (Tstep) Register (Address: 0x06)**

BIT	NAME	FUNCTION
3:0	tstep[3:0]	Time interval value used in digital shaping, in increments of $4/f_{XTAL}$

**Table 11. PA Digital Shaping Amplitude Step (PAstep) Register (Address: 0x07)**

BIT	NAME	FUNCTION
4:0	pastp[4:0]	Power step in digital shaping, in increments of 1dB

**Table 12. PA Power (PApwr) Register (Address: 0x08)**

BIT	NAME	FUNCTION
4:0	papwr[4:0]	Final PA output power setting

**Table 13. FSK High-Frequency 0 (FHigh0) Register (Address: 0x09)**

BIT	NAME	FUNCTION
7:0	fhi[15:8]	8-bit upper byte of high-frequency divider for FSK

# MAX7060

## 280MHz to 450MHz Programmable ASK/FSK Transmitter

**Table 14. FSK High-Frequency 1 (FHigh1) Register (Address: 0x0A)**

BIT	NAME	FUNCTION
7:0	fhi[7:0]	8-bit lower byte of high-frequency divider for FSK

The 4 MSBs of FHigh0, fhi[15:12], are the integer portion of the divider, excluding offset of 16. The 12 LSBs (fhi[11:0]) are the fractional part of the divider.

**Table 15. ASK Center-Frequency 0 (FCenter0) Register (Address: 0x0B)**

BIT	NAME	FUNCTION
7:0	fce[15:8]	8-bit upper byte of frequency divider for ASK

**Table 16. ASK Center-Frequency 1 (FCenter1) Register (Address: 0x0C)**

BIT	NAME	FUNCTION
7:0	fce[7:0]	8-bit lower byte of frequency divider for ASK

The 4 MSBs of FCenter0, fce[15:12], are the integer portion of the divider, excluding offset of 16. The 12 LSBs (fce[11:0]) are the fractional part of the divider.

When fce[11:0] are all zeros and ASK mode is selected (mode bit = 0), the PLL works in the fixed-N mode, which reduces current consumption and reference spurs. Set pllbw bit high (Conf0 register, bit 5). For all other combinations, the PLL works in fractional-N mode.

**Table 17. FSK Low-Frequency 0 (FLow0) Register (Address:0x0D)**

BIT	NAME	FUNCTION
7:0	flo[15:8]	8-bit upper byte of low-frequency divider for FSK

**Table 18. FSK Low-Frequency 1 (FLow1) Register (Address: 0x0E)**

BIT	NAME	FUNCTION
7:0	flo[7:0]	8-bit lower byte of low-frequency divider for FSK

The 4 MSBs of FLow0, flo[15:12], are the integer portion of the divider, excluding offset of 16. The 12 LSBs (flo[11:0]) are the fractional part of the divider.

**Table 19. Maximum and Minimum Values for Frequency Divider**

DECIMAL VALUE	fhi[15:0], fce[15:0], flo[15:0]
12.0220	0xC05A
2.9536	0x2F42

**Table 20. Frequency-Load (FLoad) Register (Address: 0x0F)**

BIT	NAME	FUNCTION
0	hop	Effectively changes the PLL frequency to the ones written in registers 0x09 to 0x0E. This is a self-reset bit and is reset to zero after the operation is completed.

## 280MHz to 450MHz Programmable ASK/FSK Transmitter

**Table 21. Enable (EnableReg) Register (Address: 0x10)**

BIT	NAME	FUNCTION
0	enable	SPI equivalent of the ENABLE pin, which should be kept low (0) if the external ENABLE pin is used. The external ENABLE pin should also be kept low (0) if the enable bit is used.

**Table 22. Data Input (DataReg) Register (Address: 0x11)**

BIT	NAME	FUNCTION
0	datain	SPI equivalent of DIN, where the transmitted data can be controlled through the SPI interface. It should be kept low (0) if only the external DIN pin is used. The external DIN pin should also be kept low (0) if the datain bit is used.

**Table 23. Status (Status) Register (Address: 0x12)**

BIT	NAME	FUNCTION
7:0	status[7:0]	Read-only status register, selected through tmux[2:0] (register 0x04 IOConf0)

**Table 24. Status Bus Signals**

tmux[2:0]	status[7]	status[6]	status[5]	status[4]	status[3]	status[2]	status[1]	status[0]
0	—	—	—	—	ckout	ckd16	ckd4	nock
1	—	—	—	—	—	—	—	—
2	—	—	—	—	enable	—	—	—
3	—	frac_fxdb	—	cap[4]	cap[3]	cap[2]	cap[1]	cap[0]
4	—	—	notover	capfxd[4]	capfxd[3]	capfxd[2]	capfxd[1]	capfxd[0]
5	integ[3]	integ[2]	integ[1]	integ[0]	frac[11]	frac[10]	frac[9]	frac[8]
6	frac[7]	frac[6]	frac[5]	frac[4]	frac[3]	frac[2]	frac[1]	frac[0]
7	—	—	—	—	—	—	lockdet	xmit_en

—	Reserved signals	frac_fxdb	Fractional-N mode (1) or ASK fixed-N mode (0)
nock	No-clock flag (1) if crystal oscillator is disabled, and (0) if clock activity is observed	capfxd[4:0]	Emulation mode variable capacitor setting
ckd4	Crystal clock signal divided by 4	notover	ASK digital shaping flag (1) when PA power value is different than 0
ckd16	Crystal clock signal divided by 16	integ[3:0]	Fractional-N 4-bit integer value
ckout	Clock output signal, according to programmed dividers (ckdiv[2:0])	frac[11:0]	Fractional-N 12-bit fractional value
enable	Internal enable signal (OR function of the ENABLE pin and enable bit)	xmit_en	Transmitter PA enable flag
cap[4:0]	SPI mode capacitor setting	lockdet	PLL lock-detect flag

# MAX7060

## 280MHz to 450MHz Programmable ASK/FSK Transmitter

### Manual Mode Settings

The MAX7060 can be operated by controlling certain pins directly, thereby eliminating the need for an SPI controller. There is a restricted selection of frequency and power settings, but operation is simpler. The pins that are used in manual mode are as follows:

Pin 1: GPO2\_MOD (modulation mode, 0 = ASK, 1 = FSK)

Pins 5, 6, 7: FREQ0, FREQ1, FREQ2

Pin 19:  $\overline{\text{CS\_DEV}}$  (FSK deviation selection, 0 =  $\pm 16\text{kHz}$ , 1 =  $\pm 50\text{kHz}$ )

Pins 20, 21: SDI\_PWR1 and SCLK\_PWR0 (2-pin power selection)

Pins 22, 23: ENABLE and DIN (PA variable capacitor setting, data input, enable)

To put the MAX7060 in manual mode, set any of the FREQ0, FREQ1, FREQ2 pins (5, 6, and 7) to logic-high. These pins are normally pulled down, so the default state of the MAX7060 is for SPI operation. The settings in Table 25 can be made in manual mode.

### Frequency Selection

There are seven internally set fractional-N divide ratios that correspond to commonly used frequencies when a 16MHz crystal is used.

Notice that the MAX7060 can be operated manually at any single frequency over its 280MHz to 450MHz operating range by choosing a crystal frequency and one of the divide ratios from Table 25. For example, a transmitting frequency of 308MHz can be achieved by selecting the 19.68750 divide ratio and a 15.6444MHz crystal.

The frequency settings in the manual mode of operation were designed in a way that allows the customer to toggle only one control line between low and high states to switch between seven commonly used frequency pairs (see Table 26).

### ASK or FSK Modulation

Reset pin 1 (GPO2\_MOD) to 0 for ASK modulation and 1 for FSK modulation. Analog shaping in ASK mode is enabled by using the ROUT pin. The turn-on and turn-off time is fixed at approximately 1 $\mu\text{s}$ .

**Table 25. Manual Mode Frequency Selection**

FREQ2	FREQ1	FREQ0	FREQUENCY (MHz)	DIVIDE RATIO
0	0	0	SPI	N/A
0	0	1	315.00	19.68750
0	1	0	433.62	27.10125
0	1	1	390.00	24.37500
1	0	0	418.00	26.12500
1	0	1	372.00	23.25000
1	1	0	345.00	21.56250
1	1	1	433.92	27.12000

**Table 26. Manual Mode Frequency Pair Switching**

LOW FREQUENCY (MHz)	HIGH FREQUENCY (MHz)	FREQ2, FREQ1, FREQ0
315.00	433.92	001 to 111. Set FREQ0 high, shorting FREQ1 and FREQ2, toggling 1 line.
418.00	433.92	100 to 111. Set FREQ2 high, shorting FREQ1 and FREQ0, toggling 1 line.
433.62	433.92	010 to 111. Set FREQ1 high, shorting FREQ2 and FREQ0, toggling 1 line.
315.00	390.00	001 to 011. Set FREQ0 high and FREQ2 low, toggling FREQ1.
315.00	372.00	001 to 101. Set FREQ1 low and FREQ0 high, toggling pin FREQ2.
345.00	433.92	110 to 111. Set FREQ2 and FREQ1 high, toggling FREQ0.
390.00	433.92	011 to 111. Set FREQ1 and FREQ0 high, toggling FREQ2.

## 280MHz to 450MHz Programmable ASK/FSK Transmitter

**Table 27. Output Power Settings**

SDI_PWR1	SCLK_PWR0	dB BELOW P <sub>MAX</sub>
0	0	0
0	1	3
1	0	6
1	1	10

### Frequency Deviation

Reset pin 19 ( $\overline{\text{CS\_DEV}}$ ) to 0 for 32kHz ( $\pm 16\text{kHz}$ ) FSK deviation and 1 for 100kHz ( $\pm 50\text{kHz}$ ) FSK deviation.

### Transmitter Power

Set SDI\_PWR1 (pin 20) and SCLK\_PWR0 (pin 21) to four power settings (relative to the maximum power setting).

Note that at battery voltages below 3V, the top two power settings are compressed and the power difference is less than 3dB.

### PA Variable Capacitor Setting

In manual mode, capacitance can be added to the PA output for one selected frequency. This allows the user to adjust the matching network when switching between two frequencies in the manual selection table, or for switching to one frequency that is significantly different from the others in the table. The user can set the capacitance by resetting the ENABLE pin to a logic-low, then selecting the frequency for which the variable capacitor is to be added from the seven possible settings, and then sending a stream of 1 to 32 pulses through the DIN pin. The first pulse is used to reset the internal capacitor counter and to latch the selected frequency. After the first pulse, the remaining number of pulses sent equals the variable capacitor setting. When the ENABLE pin goes high, the capacitor setting for the specified frequency is set, so that it adds the programmed capacitance to the PA when the chosen frequency is selected. This scheme must be executed only once to set the value of the variable capacitor.

For example, a user can operate the MAX7060 at 315MHz and 433.92MHz into a narrowband antenna by resetting the ENABLE pin low, setting the FREQ0, FREQ1, FREQ2 pins to 001 (315MHz), and sending the appropriate number of pulses into the DIN pin, and then setting the ENABLE pin high. When the frequency is set to 433.92MHz (or any other frequency in the table except 315MHz), no capacitance is added to the PA output.

When the frequency is set to 315MHz, the PA capacitance increases by the programmed value.

Figure 8 illustrates how to set the capacitance. It begins with the ENABLE pin pulled low. The frequency is sampled at the rising edge of the first pulse. Pulses 2–11 set the capacitance code to 0x0A (10dec), which is approximately 2.5pF. The ENABLE pin is then pulled high to finish the setting.

### Emulation Mode Settings

All the settings available through the manual mode of operation are also easily accessible in the SPI mode. This mode is called emulation mode, whereby only writing one or two registers, the whole transmitter can be configured. The Conf2 register controls this mode.

The emulation mode is a subset of SPI mode. It gives SPI users the capability to operate the part by programming just one or two registers instead of all registers.

Since it is still SPI mode, pins 5, 6, and 7 (FREQ0, FREQ1, and FREQ2) must be pulled low. The Conf2 register is the only register that needs to be programmed. Setting bit 7 (fixed) to 1 enables this mode. Bit 6 (fxmode) is equivalent to pin 1 (GPO2\_MOD) in manual mode. Bits 5 and 4 (fxpwr[1:0]) are equivalent to pin 20 and 21 (SDI\_PWR1 and SCLK\_PWR0) in manual mode. Bit 3 (fxhdev) is equivalent to pin 19 ( $\overline{\text{CS\_DEV}}$ ) in manual mode. Bits 2, 1, and 0 (fxfrq[2:0]) are equivalent to pins 5, 6, and 7 (FREQ0, FREQ1, and FREQ2) in manual mode.

Similar to manual mode, the PA capacitor setting in the emulation mode can be done by toggling the DIN pin with the ENABLE pin low. In addition, the capacitor setting can also be done by directly writing to the capacitor register (bits 4:0 of the Conf1 register, cap[4:0]). As long as the capacitor register value is not zero, the capacitor value sent in by toggling the DIN pin is ignored.

### Control Interface Considerations

When operating the MAX7060 with a +4.5V to +5.5V supply voltage, the  $\overline{\text{CS\_DEV}}$ , SCLK\_PWR0, SDI\_PWR1, FREQ0, FREQ1, FREQ2, ENABLE, DIN, and LSHDN pins can be driven by a microcontroller with either 3V or 5V interface logic levels. When operating the MAX7060 with a +2.1V to +3.6V supply, the microcontroller must produce logic levels that conform to the V<sub>IH</sub> and V<sub>IL</sub> specifications in the *DC Electrical Characteristics* for the MAX7060.

# MAX7060

## 280MHz to 450MHz Programmable ASK/FSK Transmitter

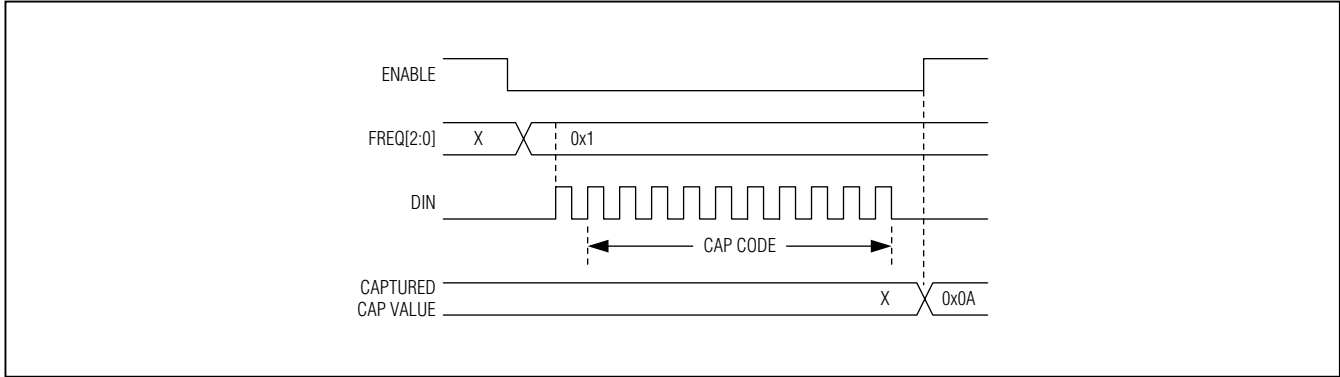
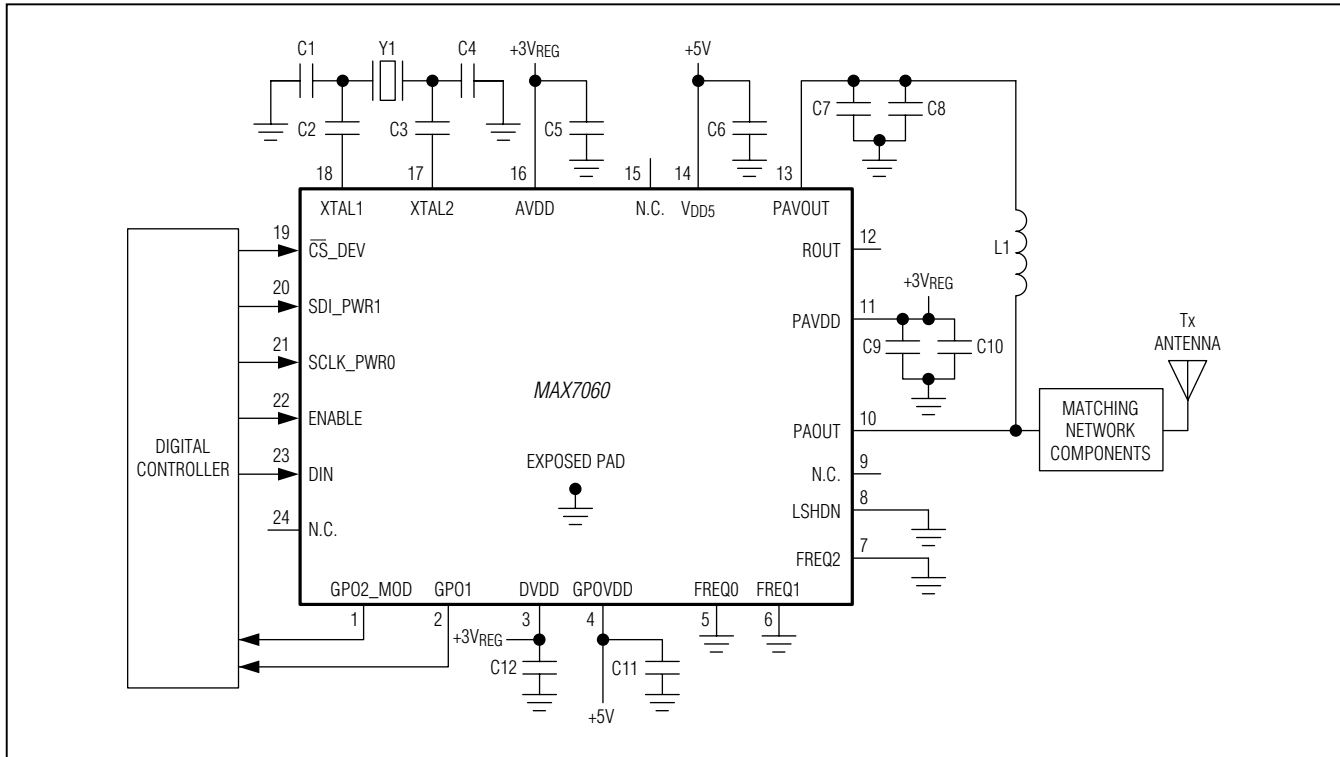

Figure 8. Variable Capacitor Setting Timing Diagram

### Typical Application Circuits

#### SPI Mode (5V Supply)



# MAX7060

## 280MHz to 450MHz Programmable ASK/FSK Transmitter

### Typical Application Circuits (continued)

#### Manual Mode (3V Supply, Shaped ASK Modulation, 315MHz)

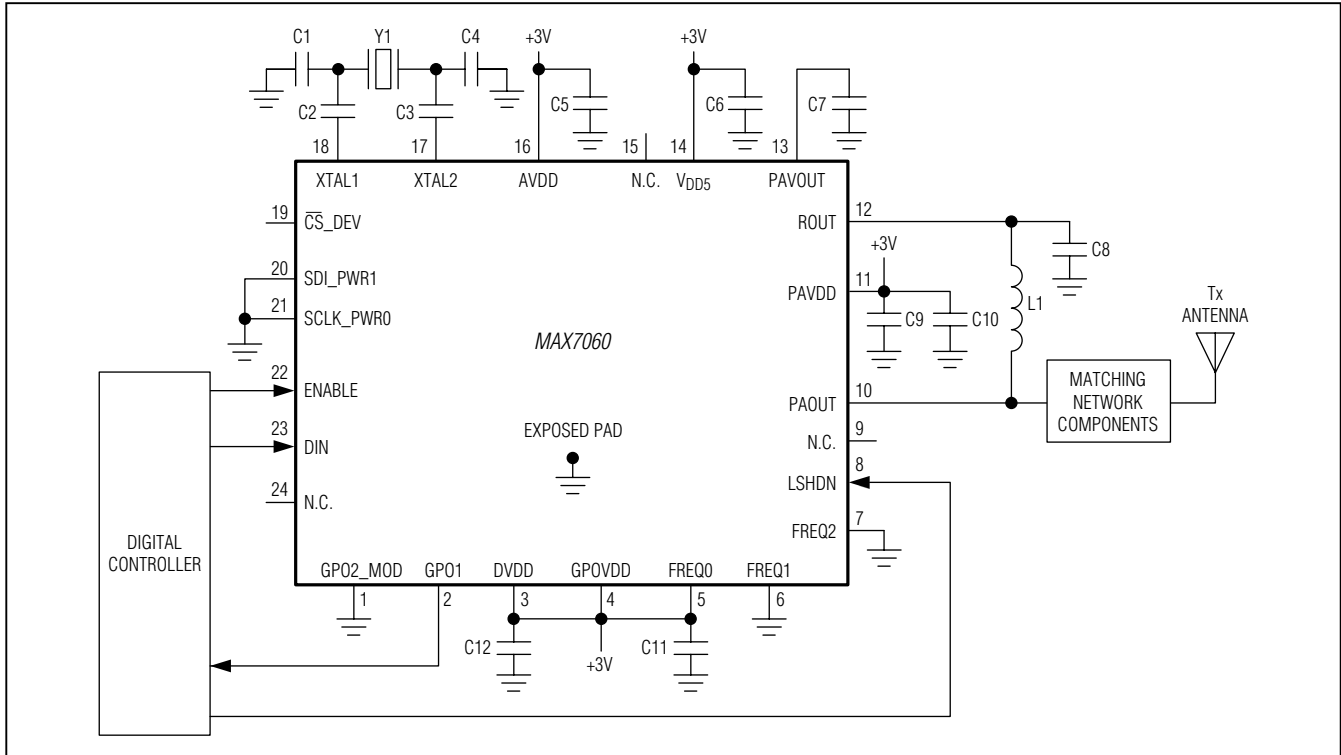

### Component List

DESIGNATION	QTY	DESCRIPTION
C1, C4	2	May not be needed for low $C_{LOAD}$ crystals, depending on PCB layout parasitics
C2, C3	2	1.5nF $\pm 10\%$ , 50V X7R ceramic capacitors (0603) Murata GRM188R71H152K
C5, C6	2	100nF $\pm 10\%$ , 50V X7R ceramic capacitors (0603) Murata GRM188R71H104K
C7, C8, C9	3	220pF $\pm 5\%$ ceramic capacitors (0603) Murata GRM1885C1H220JA01D
C10, C11, C12	3	10nF $\pm 10\%$ , 50V X7R ceramic capacitors (0603) Murata GRM188R71H103K
L1	1	$\pm 5\%$ wire-wound inductor (0603) Murata LQW18 series (value depends on matching network)
Matching Network Components	4	3 capacitors and 1 inductor (values depend on frequency range and antenna impedance)
U1	1	Maxim MAX7060ATG+
Y1	1	16MHz crystal, 10pF $C_{LOAD}$ Crystek 17466 Suntsu SCX284

# MAX7060

## 280MHz to 450MHz Programmable ASK/FSK Transmitter

### Chip Information

PROCESS: CMOS

### Package Information

For the latest package outline information and land patterns (footprints), go to [www.maximintegrated.com/packages](http://www.maximintegrated.com/packages). Note that a "+", "#", or "-" in the package code indicates RoHS status only. Package drawings may show a different suffix character, but the drawing pertains to the package regardless of RoHS status.

PACKAGE TYPE	PACKAGE CODE	OUTLINE NO.	LAND PATTERN NO.
24 TQFN-EP	T2444+3	<a href="#">21-0139</a>	<a href="#">90-0021</a>

# MAX7060

## 280MHz to 450MHz Programmable ASK/FSK Transmitter

### Revision History

REVISION NUMBER	REVISION DATE	DESCRIPTION	PAGES CHANGED
0	2/10	Initial release	—
1	2/12	Power dissipation and derating factor shown for wrong package type; clarified GPO1 boost mode and nature of analog and digital ASK envelope shaping. Added paragraph on control interface considerations; updated <i>Typical Application Circuits</i> to add exposed pad (grounded); and specified typical load C on crystal in component list	2, 14, 15, 19, 21, 27, 28, 29



Maxim Integrated cannot assume responsibility for use of any circuitry other than circuitry entirely embodied in a Maxim Integrated product. No circuit patent licenses are implied. Maxim Integrated reserves the right to change the circuitry and specifications without notice at any time. The parametric values (min and max limits) shown in the Electrical Characteristics table are guaranteed. Other parametric values quoted in this data sheet are provided for guidance.

**Maxim Integrated 160 Rio Robles, San Jose, CA 95134 USA 1-408-601-1000**

**31**

## Looking for pricing, stock, or lifecycle information?

Click below to explore more details on WIN SOURCE:

- ⊖ [View MAX7060ATG/V+T on WIN SOURCE](#)
- ⊖ [Maxim Integrated Information](#)

## Optimize Your Supply Chain with WIN SOURCE Solutions

- ✓ Global Sourcing Solution
- ✓ Obsolete Management
- ✓ Cost Control Management
- ✓ Shortage Management
- ✓ Alternative Solution
- ✓ Excess Inventory Management