



**THE DATASHEET OF
MAX4895EETE+T**





VGA Port Protector

MAX4895E

General Description

The MAX4895E integrates level-translating buffers and features R, G, B port protection for VGA signals.

The MAX4895E has H, V (horizontal, vertical) translating buffers that take low-level CMOS inputs from the graphics outputs to meet full +5.0V, TTL-compatible outputs. Each output can drive $\pm 10\text{mA}$ and meet the VESA® specification. In addition, the device takes the +5.0V, direct digital control (DDC) signals and translates them to the lower level required by the graphics device. This level is set by the user by connecting V_L to the graphics output supply. The R, G, B terminals protect the graphics output pins against electrostatic discharge (ESD) events. All seven outputs have high-level ESD protection.

The MAX4895E is specified over the extended -40°C to $+85^\circ\text{C}$ temperature range, and is available in a 16-pin, 3mm x 3mm TQFN package.

Applications

Notebook Computers
Desktops
Servers
Graphics Cards

VESA is a registered service mark of Video Electronics Standards Association Corporation.

Features

- ◆ ESD Protection on H1, V1, SDA1, SCL1, R, G, and B
 $\pm 15\text{kV}$ —Human Body Model
 $\pm 8\text{kV}$ —IEC 61000-4-2, Contact Discharge
- ◆ Low Quiescent Current, $I_Q \leq 5\mu\text{A}$ (max)
- ◆ Low 3pF (max) Capacitance (R, G, B Ports)
- ◆ DDC Level-Shifting Protection and Isolation
- ◆ Horizontal Sync, Vertical Sync Level Shifting/ Buffering
- ◆ Input Compatible with V_L
- ◆ Output Full +5.0V TTL Compatible (per VESA)
- ◆ $\pm 10\text{mA}$ Drive on Each H, V Terminal
- ◆ Space-Saving, Lead-Free, 16-Pin (3mm x 3mm) TQFN Package

Ordering Information

PART	TEMP RANGE	PIN-PACKAGE
MAX4895EETE+	-40°C to $+85^\circ\text{C}$	16 TQFN-EP*

+Denotes a lead(Pb)-free/RoHS-compliant package.

*EP = Exposed pad.

Typical Operating Circuit

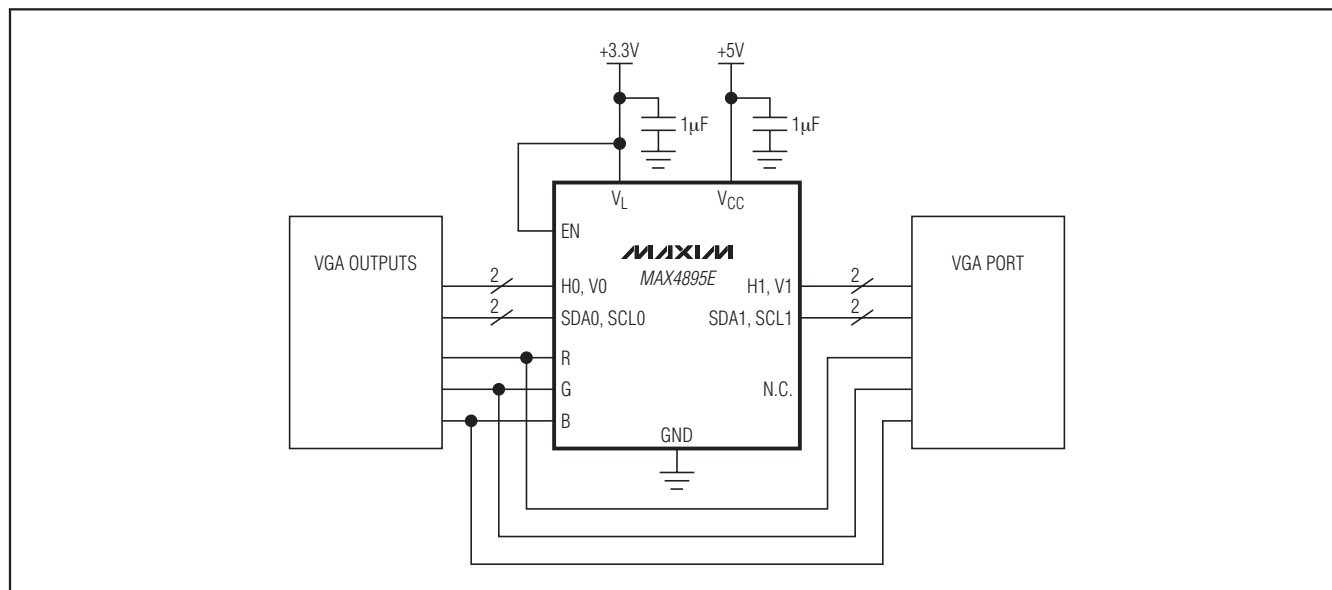

VGA Port Protector

ABSOLUTE MAXIMUM RATINGS

(All voltages referenced to GND.)

V _{CC}	-0.3V to +6.0V
V _L	-0.3V to +(V _{CC} + 0.3V)
R, G, B, H1, V1, SCL1, SDA1	-0.3V to +(V _{CC} + 0.3V)
EN, H0, V0, SCL0, SDA0	-0.3V to +(V _L + 0.3V)
Continuous Current through SDA ₋ , SCL ₋	±30mA
Continuous Short-Circuit Current H1, V1	±20mA

Continuous Power Dissipation (T _A = +70°C) for multilayer board:	
16-Pin TQFN (derate 20.8mW/°C above +70°C)	1667mW
Junction-to-Case Thermal Resistance (θ _{JC}) (Note 1)	7°C/W
Junction-to-Ambient Thermal Resistance (θ _{JA}) (Note 1)	48°C/W
Operating Temperature Range	-40°C to +85°C
Junction Temperature	+150°C
Storage Temperature Range	-65°C to +150°C
Lead Temperature (soldering, 10s)	+300°C
Soldering Temperature (reflow)	+260°C

Note 1: Package thermal resistances were obtained using the method described in JEDEC specification JESD51-7, using a four-layer board. For detailed information on package thermal considerations, refer to www.maxim-ic.com/thermal-tutorial.

Stresses beyond those listed under "Absolute Maximum Ratings" may cause permanent damage to the device. These are stress ratings only, and functional operation of the device at these or any other conditions beyond those indicated in the operational sections of the specifications is not implied. Exposure to absolute maximum rating conditions for extended periods may affect device reliability.

ELECTRICAL CHARACTERISTICS

(V_{CC} = +4.5V to +5.5V, V_L = +2.0V to V_{CC}, T_A = T_{MIN} to T_{MAX}, unless otherwise noted. Typical values are at V_{CC} = +5.0V, V_L = +3.3V, and T_A = +25°C.) (Note 2)

PARAMETER	SYMBOL	CONDITIONS	MIN	TYP	MAX	UNITS
SUPPLY OPERATION						
Supply Voltage	V _{CC}		4.5		5.5	V
Logic Supply Voltage	V _L	V _L ≤ V _{CC}	2	3.3	5.5	V
V _{CC} Supply Current	I _{CC}	V _{H0} , V _{V0} = 0V, V _{EN} = V _L		0.5	5.0	μA
V _L Supply Current	I _L	V _{H0} , V _{V0} = 0V, V _{EN} = V _L (no load)		0.5	5.0	μA
RGB CHANNELS						
R, G, B Capacitance	C _{OUT}	f = 1MHz, V _{R,G,B} = 1V _{P-P} (Note 3)		2.2		pF
R, G, B Leakage		V _{CC} = +5.5V	-1		+1	μA
H₋, V₋, EN CHANNELS						
Input Threshold Low	V _{IL}	V _L = +3.0V			0.8	V
Input Threshold High	V _{IH}	V _L = +3.6V	2.0			V
Input Hysteresis	V _{HYST}			100		mV
Input Leakage Current	I _{LEAK}	V _L = +3.3V, V _{CC} = +5.5V	-1		+1	μA
Output-Voltage Low	V _{OL}	I _{OUT} = 10mA sink, V _{CC} = +4.5V			0.8	V
Output-Voltage High	V _{OH}	I _{OUT} = 10mA source, V _{CC} = +4.5V	2.4			V
Propagation Delay	t _{PD}	R _L = 2.2kΩ, C _L = 10pF, V _{OL} = +0.8V, V _{OH} = +2.4V		15		ns
Enable Time	t _{ON} , t _{OFF}			15		ns
SDA₋, SCL₋ (DDC) CHANNELS						
On-Resistance, SDA, SCL	R _{ON}	V _{CC} = +5.5V, I _{SDA} , I _{SCL} = ±10mA, V _{SDA} , V _{SCL} = +0.5V		20	55	Ω
Leakage Current, SDA, SCL	I _{LEAK}	V _L = 0V	-1		+1	μA

VGA Port Protector

MAX4895E

ELECTRICAL CHARACTERISTICS (continued)

($V_{CC} = +4.5V$ to $+5.5V$, $V_L = +2.0V$ to V_{CC} , $T_A = T_{MIN}$ to T_{MAX} , unless otherwise noted. Typical values are at $V_{CC} = +5.0V$, $V_L = +3.3V$, and $T_A = +25^\circ C$.) (Note 2)

PARAMETER	SYMBOL	CONDITIONS	MIN	TYP	MAX	UNITS
ESD PROTECTION						
SDA1, SCL1, H1, V1, R, G, B		Human Body Model (Note 4)		±15		kV
SDA1, SCL1, H1, V1, R, G, B		IEC 61000-4-2 Contact		±8		kV

Note 2: All devices are 100% production tested at $T_A = +25^\circ C$. All temperature limits are guaranteed by design.

Note 3: Guaranteed by design, not production tested.

Note 4: Tested terminals to GND; $1\mu F$ bypass capacitors on V_{CC} and V_L .

Typical Operating Characteristics

($V_{CC} = +5.0V$, $V_L = +3.3V$, and $T_A = +25^\circ C$, unless otherwise noted.)

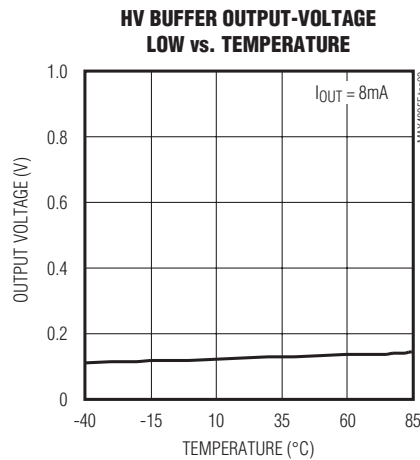
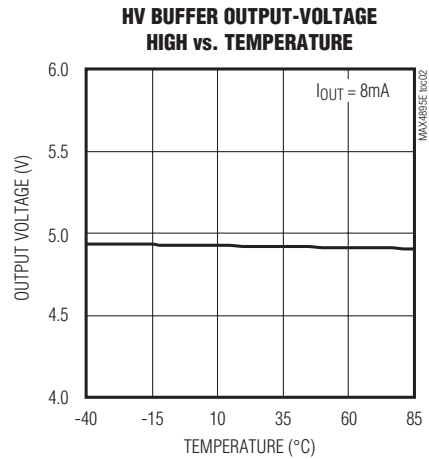
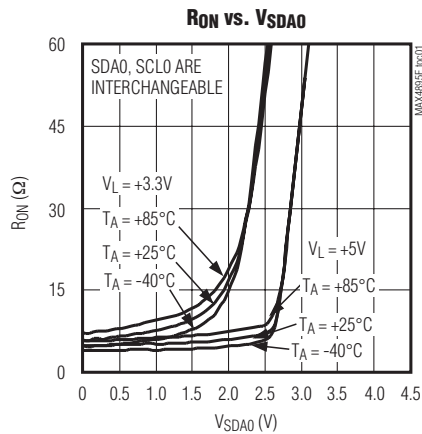

VGA Port Protector

Pin Configuration

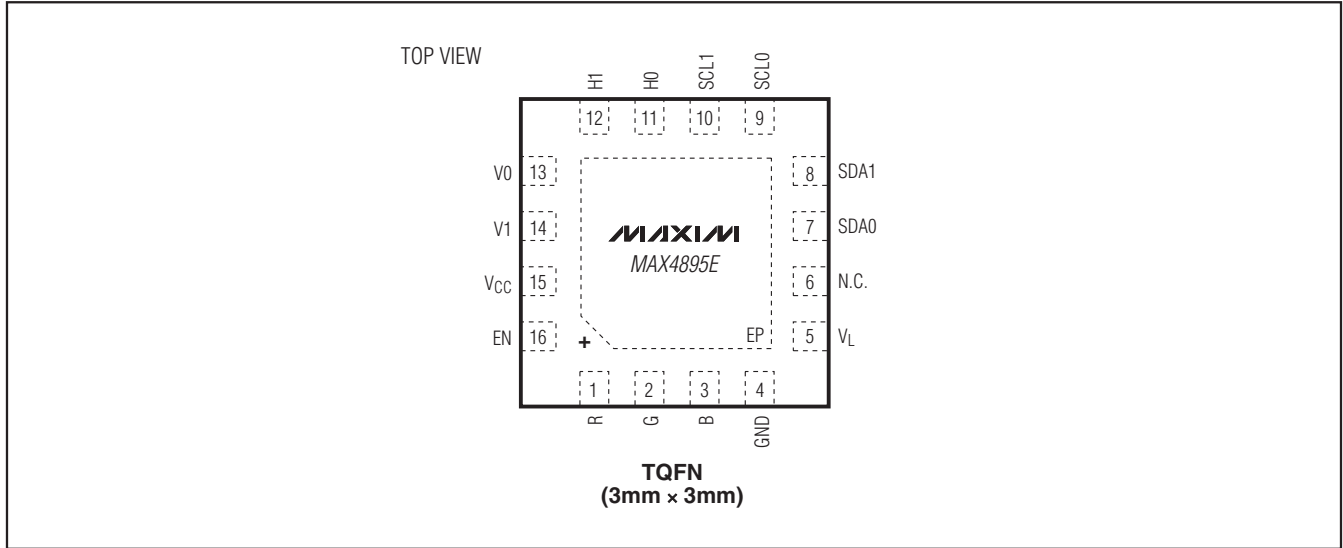

Pin Description

PIN	NAME	FUNCTION
1	R	High-ESD Protection Diodes for RGB Signals
2	G	High-ESD Protection Diodes for RGB Signals
3	B	High-ESD Protection Diodes for RGB Signals
4	GND	Ground
5	V _L	Supply Voltage, +2.0V to V _{CC} . Bypass V _L to GND with a 1μF ceramic capacitor.
6	N.C.	No Connection. Leave unconnected.
7	SDA0	SDA I/O. SDA0 referenced to V _L .
8	SDA1	SDA I/O. SDA1 referenced to V _{CC} .
9	SCL0	SCL I/O. SCL0 referenced to V _L .
10	SCL1	SCL I/O. SCL1 referenced to V _{CC} .
11	H0	Horizontal Sync Input
12	H1	Horizontal Sync Output
13	V0	Vertical Sync Input
14	V1	Vertical Sync Output
15	V _{CC}	Power-Supply Voltage, +4.5V to +5.5V. Bypass V _{CC} to GND with a 1μF ceramic capacitor.
16	EN	Enable for H1 and V1 Outputs
—	EP	Exposed Pad. Connect EP to GND or leave unconnected. For enhanced thermal dissipation, connect EP to a copper area as large as possible. Do not use EP as a sole ground connection.

VGA Port Protector

Functional Diagram

MAX4895E

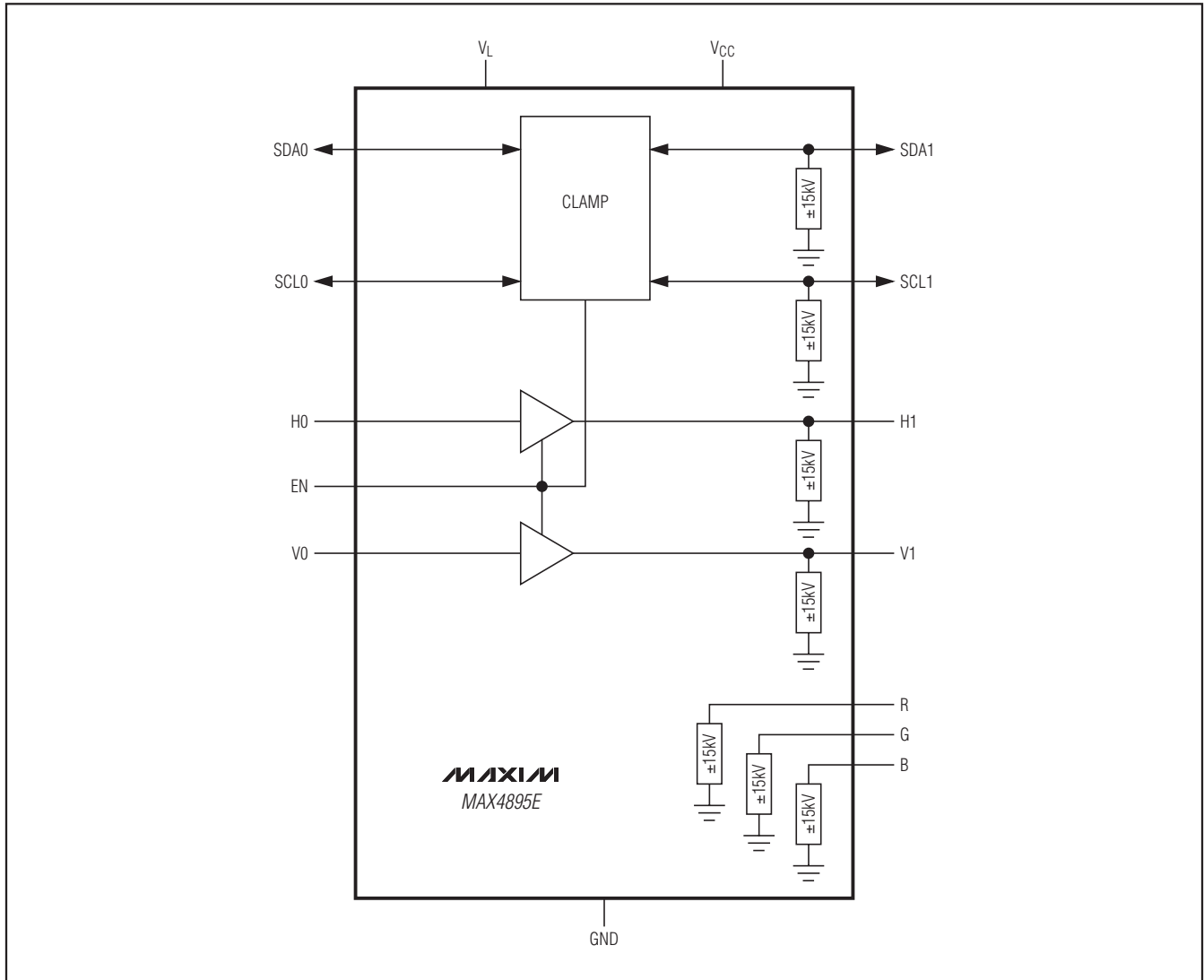

Applications Information

The MAX4895E provides the level shifting necessary to drive two standard VGA ports from a graphics controller as low as +2.2V. Internal buffers drive the HSYNC and VSYNC signals to VGA standard TTL levels. The DDC switch provides level shifting by clamping signals to a diode drop less than V_L (see the *Typical Operating Circuit*). Connect V_L to +3.3V for normal operation.

Power-Supply Decoupling

Bypass V_{CC} and V_L to ground with a $1\mu\text{F}$ ceramic capacitor as close as possible to the device.

PCB Layout

High-speed switches such as the MAX4895E require proper PCB layout for optimum performance. Ensure that impedance-controlled PCB traces for high-speed signals are matched in length and are as short as possible. Connect the exposed pad to a solid ground plane.

VGA Port Protector

Detailed Description

The MAX4895E integrates level-translating buffers and features R, G, B port protection for VGA signals.

Horizontal and vertical synchronization (H0/V0) inputs feature level-shifting buffers to support low-voltage CMOS or standard TTL-compatible graphics controllers. The device meets $\pm 10\text{mA}$ VESA drive requirements. The MAX4895E also features I²C level shifting using two nMOS devices. All outputs maintain $\pm 15\text{kV}$ Human Body Model (HBM) and $\pm 8\text{kV}$ Contact Discharge per IEC 61000-4-2 on seven terminals (SDA1, SCL1, H1, V1, R, G, B). The R, G, B pads protect the digital-to-analog converter (DAC) and are simply placed in parallel with the R, G, B outputs for the DAC and VGA socket.

Horizontal/Vertical Sync Level Shifter

HSYNC/VSYNC are buffered to provide level shifting and drive capability to meet the VESA specification. Input logic levels (V_{IL} , V_{IH}) are connected to V_L (see the *Electrical Characteristics* table). The level-shifted outputs (H1 and V1) are pulled low when EN is driven low (see Table 1). Logic-level output (V_{OL} , V_{OH}) are +5.0V TTL compatible.

Table 1. HV Truth Table

EN	FUNCTION
1	HSYNC/VSYNC level shifting enabled
0	H1, V1 = 0

Table 2. DDC Truth Table

EN	FUNCTION
1	SDA0 to SDA1 SCL0 to SCL1
0	SDA1, SCL1, high impedance

Display Data Channel Switches

The MAX4895E incorporates two nMOS switches for I²C level shifting. The SDA, SCL terminals are voltage clamped to a diode drop less than the V_L voltage. Voltage clamping provides protection and compatibility with SDA, SCL signals and low-voltage ASICs. Supply +2.5V to +3.3V on V_L to provide voltage clamping for VESA I²C-compatible signals. The SDA, SCL switches are identical, and each switch can be used to route SDA or SCL signals.

RGB

There are three terminals for R, G, and B. The only function of these terminals is to provide high-level ESD protection to the RGB lines, while at the same time, keeping the capacitance on the RGB lines to a minimum. The R, G, B terminals are identical, and any of the three terminals can be used to protect red, green, or blue video signals.

ESD Protection

As with all Maxim devices, ESD-protection structures are incorporated on all terminals to protect against electrostatic discharges encountered during handling and assembly. Additionally, the MAX4895E is protected to $\pm 15\text{kV}$ on the RGB terminals and outputs H1, V1, SDA1, and SCL1 by the Human Body Model (HBM). For optimum ESD performance, bypass V_{CC} to ground with a $1\mu\text{F}$ ceramic capacitor.

ESD protection can be tested in various ways. The R, G, B terminals and outputs H1, V1, SDA1, and SCL1 of the MAX4895E are characterized for protection to the following limits:

- $\pm 15\text{kV}$ using the Human Body Model
- $\pm 8\text{kV}$ IEC 61000-4-2 Contact Discharge

ESD Test Conditions

ESD performance depends on a variety of conditions. Contact Maxim for a reliability report documenting test setup, methodology, and results.

VGA Port Protector

MAX4895E

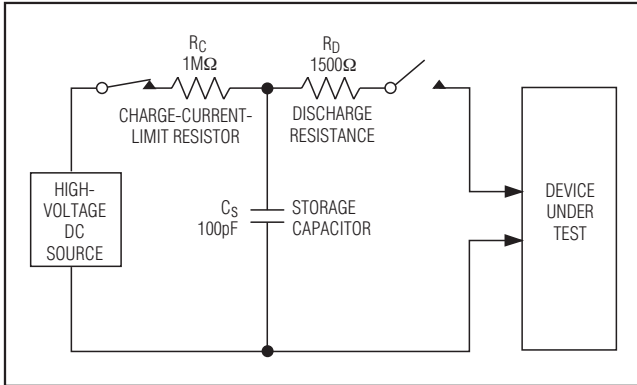

Figure 1a. Human Body ESD Test Model

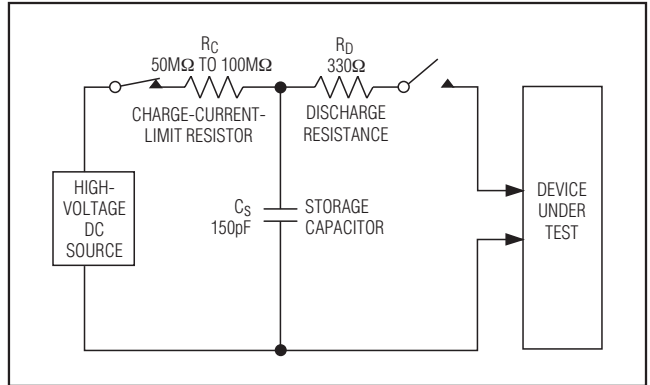

Figure 1c. IEC 61000-4-2 ESD Test Model

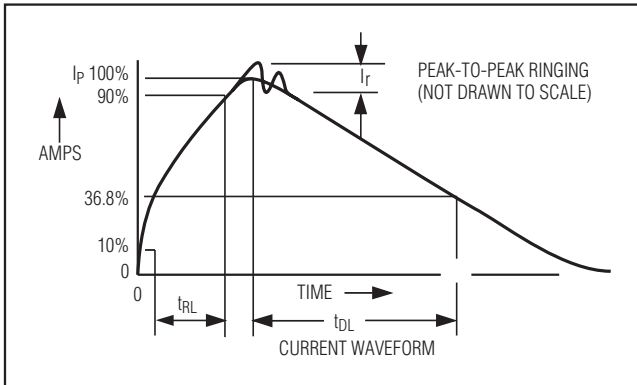

Figure 1b. Human Body Current Waveform

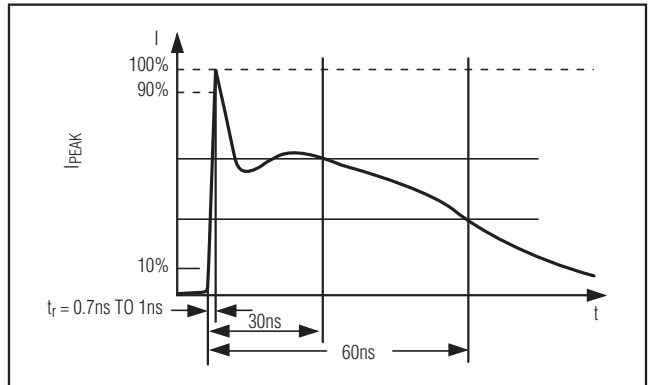

Figure 1d. IEC 61000-4-2 ESD Generator Current Waveform

Human Body Model (HBM)

Figure 1a shows the Human Body Model, and Figure 1b shows the current waveform it generates when discharged into a low impedance. This model consists of a 100pF capacitor charged to the ESD voltage of interest that is then discharged into the test device through a 1.5kΩ resistor.

IEC 61000-4-2

The IEC 61000-4-2 standard covers ESD testing and performance of finished equipment. However, it does not specifically refer to integrated circuits. The MAX4895E assists in designing equipment to meet IEC 61000-4-2 without the need for additional ESD-protection components.

The major difference between tests done using the Human Body Model and IEC 61000-4-2 is higher peak current in IEC 61000-4-2 because series resistance is

lower in the IEC 61000-4-2 model. Hence, the ESD withstand voltage measured to IEC 61000-4-2 is generally lower than that measured using the Human Body Model. Figure 1c shows the IEC 61000-4-2 model, and Figure 1d shows the current waveform for IEC 61000-4-2 ESD Contact Discharge test.

Chip Information

PROCESS: BiCMOS

Package Information

For the latest package outline information and land patterns, go to www.maxim-ic.com/packages. Note that a "+", "#", or "-" in the package code indicates RoHS status only. Package drawings may show a different suffix character, but the drawing pertains to the package regardless of RoHS status.

PACKAGE TYPE	PACKAGE CODE	OUTLINE NO.	LAND PATTERN NO.
16 TQFN-EP	T1633+4	21-0136	90-0031

VGA Port Protector

Revision History

REVISION NUMBER	REVISION DATE	DESCRIPTION	PAGES CHANGED
0	4/09	Initial release	—
1	6/10	Deleted the “Top Mark” column from the <i>Ordering Information</i>	1

Maxim cannot assume responsibility for use of any circuitry other than circuitry entirely embodied in a Maxim product. No circuit patent licenses are implied. Maxim reserves the right to change the circuitry and specifications without notice at any time.

8 **Maxim Integrated Products, 120 San Gabriel Drive, Sunnyvale, CA 94086 408-737-7600**

Looking for pricing, stock, or lifecycle information?

Click below to explore more details on WIN SOURCE:

- ⊖ [View MAX4895EETE+T on WIN SOURCE](#)
- ⊖ [Maxim Integrated Information](#)

Optimize Your Supply Chain with WIN SOURCE Solutions

- ✓ Global Sourcing Solution
- ✓ Obsolete Management
- ✓ Cost Control Management
- ✓ Shortage Management
- ✓ Alternative Solution
- ✓ Excess Inventory Management