



**THE DATASHEET OF  
MAX4766CETA+TG47**



**MAXIM**

# 0.075A to 1.5A, Programmable Current-Limit Switch

**MAX4766**

## General Description

The MAX4766 is a programmable current-limit switch that uses a proprietary control topology to provide a  $\pm 10\%$  accurate current limit. It operates from 2.25V to 4.5V input voltage.

The current limit is resistor settable from 0.075A to 1.5A and features an adjustable soft-start function to control the output-voltage ramp rate, thereby limiting the inrush current. It also has an adjustable blanking time to accommodate various capacitive loads.

If the load current is greater than the current-limit threshold, the current limiter handles the overcurrent situation in one of three ways depending on the option selected. It enters an autoretry mode (MAX4766A), latches off the switch (MAX4766B), or places the device in a continuous current-limit mode (MAX4766C). Additional safety features include thermal shutdown to prevent overheating and reverse-current blocking to prevent current from being driven back into the source.

The MAX4766 is available in a tiny 8-pin 3mm x 3mm TDFN package and operates over the extended temperature range of  $-40^{\circ}\text{C}$  to  $+85^{\circ}\text{C}$ .

## Applications

SDIO Ports  
Notebook Computers  
PDAs and Palmtop Devices  
Cell Phones

## Pin Configuration

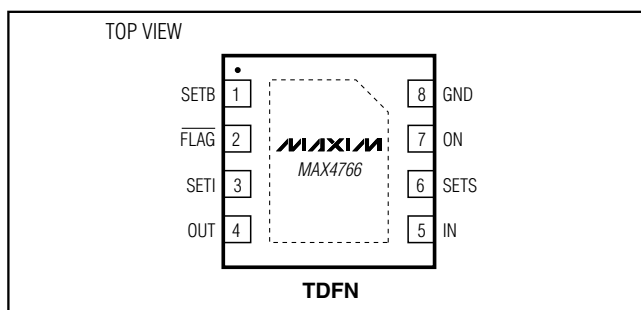

## Features

- ◆  $\pm 10\%$  Accurate Current Limit
- ◆ 0.075A to 1.5A Programmable Current Limit
- ◆ Inrush Current Protection
- ◆ Thermal Shutdown Protection
- ◆ Reverse-Current Protection
- ◆ Low Dropout Voltage
- ◆ Programmable Blanking Time
- ◆ Programmable Soft-Start Time
- ◆ FLAG Function (MAX4766B/MAX4766C)
- ◆ Tiny 8-Pin TDFN Package (3mm x 3mm)
- ◆ 2.25V to 4.5V Supply Range

## Typical Operating Circuit

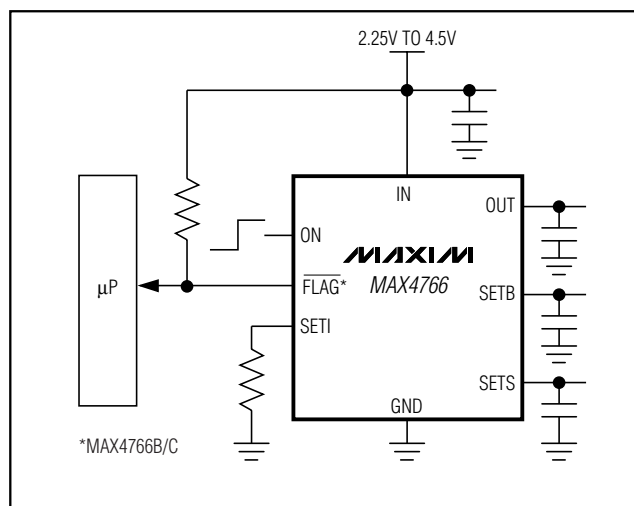

## Ordering Information/Selector Guide

PART	TEMP RANGE	PIN-PACKAGE	TOP MARK	PKG CODE	SOFT-START/ BLANKING	OVERCURRENT RESPONSE
MAX4766AETA	$-40^{\circ}\text{C}$ to $+85^{\circ}\text{C}$	8 TDFN	AKV	T833-1	Programmable	Autoretry
MAX4766BETA	$-40^{\circ}\text{C}$ to $+85^{\circ}\text{C}$	8 TDFN	AKW	T833-1	Programmable	Latch-Off
MAX4766CETA	$-40^{\circ}\text{C}$ to $+85^{\circ}\text{C}$	8 TDFN	AKX	T833-1	Programmable	Continuous

**MAXIM**

Maxim Integrated Products 1

For pricing, delivery, and ordering information, please contact Maxim/Dallas Direct! at 1-888-629-4642, or visit Maxim's website at [www.maxim-ic.com](http://www.maxim-ic.com).

# 0.075A to 1.5A, Programmable Current-Limit Switch

## ABSOLUTE MAXIMUM RATINGS

IN, OUT, ON, FLAG to GND .....-0.3V to +5V  
 SETB, SETS, SETI to GND .....-0.3V to (V<sub>IN</sub> + 0.3V)  
 IN to OUT .....±5V  
 OUT Short-Circuit Duration .....Continuous  
 Continuous Switch Current .....1.75A  
 Current into any Pin (Except IN, OUT).....±20mA  
 Continuous Power Dissipation (T<sub>A</sub> = +70°C)  
 8-Pin TDFN (derate 18.2mW/°C above +70°C)...455mW (T833-1)

Operating Temperature Range .....-40°C to +85°C  
 Junction Temperature .....+150°C  
 Storage Temperature Range .....-65°C to +150°C  
 Human Body Model ESD Protection .....±2kV  
 Lead Temperature (soldering, 10s) .....+300°C

Stresses beyond those listed under "Absolute Maximum Ratings" may cause permanent damage to the device. These are stress ratings only, and functional operation of the device at these or any other conditions beyond those indicated in the operational sections of the specifications is not implied. Exposure to absolute maximum rating conditions for extended periods may affect device reliability.

## ELECTRICAL CHARACTERISTICS

(V<sub>IN</sub> = 2.25V to 4.5V, C<sub>OUT</sub> = 2.2μF, T<sub>A</sub> = -40°C to +85°C, unless otherwise noted. Typical values are at T<sub>A</sub> = +25°C, unless otherwise noted.) (Note 1)

PARAMETER	SYMBOL	CONDITIONS	MIN	TYP	MAX	UNITS
Operating Voltage Range	V <sub>IN</sub>		2.25		4.5	V
Undervoltage Lockout	V <sub>UVLO</sub>	V <sub>IN</sub> rising	1.6		2.0	V
Undervoltage Lockout Hysteresis				125		mV
Quiescent Current	I <sub>Q</sub>	I <sub>OUT</sub> = 0, switch on, R <sub>SETI</sub> = 0Ω (I <sub>LIMIT</sub> = 1.5A)		35	85	μA
		I <sub>OUT</sub> = 0, switch on, R <sub>SETI</sub> = 200.9kΩ (I <sub>LIMIT</sub> = 0.56A)		95	135	
		I <sub>OUT</sub> = 0, switch on, R <sub>SETI</sub> = 1500kΩ (I <sub>LIMIT</sub> = 0.075A)		75	120	
Shutdown Current	I <sub>SHDN</sub>	V <sub>IN</sub> = 3.6V, V <sub>ON</sub> = 0, V <sub>OUT</sub> = 0V, T <sub>A</sub> = +25°C			0.1	μA
		V <sub>IN</sub> = 3.6V, V <sub>ON</sub> = 0, V <sub>OUT</sub> = 0V, T <sub>A</sub> = +85°C			13.5	
		V <sub>IN</sub> = 4.0V, V <sub>ON</sub> = 0, V <sub>OUT</sub> = 0V, T <sub>A</sub> = +25°C			0.12	
		V <sub>IN</sub> = 4.0V, V <sub>ON</sub> = 0, V <sub>OUT</sub> = 0V, T <sub>A</sub> = +85°C			18	
Current Limit	I <sub>LIM</sub>	V <sub>OUT</sub> = 0V, R <sub>SETI</sub> = 0Ω (V <sub>IN</sub> = 2.25 to 4.0V)	1.35	1.50	1.67	A
		V <sub>OUT</sub> = 0V, R <sub>SETI</sub> = 200.9kΩ (V <sub>IN</sub> = 2.25 to 4.0V)	537	590	640	
		V <sub>OUT</sub> = 0V, R <sub>SETI</sub> = 1500kΩ (V <sub>IN</sub> = 2.25 to 3.6V)	73	79.5	85.5	mA
		V <sub>OUT</sub> = 0V, R <sub>SETI</sub> = 1500kΩ (V <sub>IN</sub> = 2.25 to 4.0V)	73	80	87	

# 0.075A to 1.5A, Programmable Current-Limit Switch

MAX4766

## ELECTRICAL CHARACTERISTICS (continued)

( $V_{IN} = 2.25V$  to  $4.5V$ ,  $C_{OUT} = 2.2\mu F$ ,  $T_A = -40^\circ C$  to  $+85^\circ C$ , unless otherwise noted. Typical values are at  $T_A = +25^\circ C$ , unless otherwise noted.) (Note 1)

PARAMETER	SYMBOL	CONDITIONS	MIN	TYP	MAX	UNITS
RSETI $I_{LIM}$ Product		$0.075A \leq I_{LIMIT} \leq 1.5A$ , $V_{OUT} = 0V$	101	112.5	124	kV
Switch Dropout Voltage (Note 2)		$V_{ON} = V_{IN} = 3V$ , $I_{OUT} = 0.9 \times I_{LIMIT(min)}$ , $R_{SETI} = 0\Omega$ (typical $I_{LIMIT} = 1.5A$ )			290	mV
		$V_{ON} = V_{IN} = 3V$ , $I_{OUT} = 0.33 \times I_{LIMIT(min)}$ , $R_{SETI} = 0\Omega$ (typical $I_{LIMIT} = 1.5A$ )			105	
		$V_{ON} = V_{IN} = 3V$ , $I_{OUT} = 0.9 \times I_{LIMIT(min)}$ , $R_{SETI} = 200.9k\Omega$ (typical $I_{LIMIT} = 0.56A$ )			245	
Forward-Off Switch Leakage Current	$I_{OUT(OFF)}$	$V_{IN} = 3.6V$ , $V_{ON} = 0V$ , $V_{OUT} = 0V$ , $T_A = +25^\circ C$			0.1	$\mu A$
		$V_{IN} = 3.6V$ , $V_{ON} = 0V$ , $V_{OUT} = 0V$ , $T_A = +85^\circ C$			13.5	
		$V_{IN} = 4.0V$ , $V_{ON} = 0V$ , $V_{OUT} = 0V$ , $T_A = +25^\circ C$			0.12	
		$V_{IN} = 4.0V$ , $V_{ON} = 0V$ , $V_{OUT} = 0V$ , $T_A = +85^\circ C$			18	
Reverse Leakage Current (Device Disabled)	$I_{INR(OFF)}$	$V_{IN} = 0V$ , $V_{OUT} = 3.6V$ , $V_{ON} = 0V$ , $T_A = +25^\circ C$			0.1	$\mu A$
		$V_{IN} = 0V$ , $V_{OUT} = 3.6V$ , $V_{ON} = 0V$ , $T_A = +85^\circ C$			13.8	
		$V_{IN} = 0V$ , $V_{OUT} = 4.0V$ , $V_{ON} = 0V$ , $T_A = +25^\circ C$			0.125	
		$V_{IN} = 0V$ , $V_{OUT} = 4.0V$ , $V_{ON} = 0V$ , $T_A = +85^\circ C$			18	
Reverse Leakage Current (Device Enabled)	$I_{INR(OFF)}$	$V_{IN} = 0V$ , $V_{OUT} = 3.6V$ , $V_{ON} = V_{OUT}$ , $T_A = +25^\circ C$			0.17	$\mu A$
		$V_{IN} = 0V$ , $V_{OUT} = 3.6V$ , $V_{ON} = V_{OUT}$ , $T_A = +85^\circ C$			30	
		$V_{IN} = 0V$ , $V_{OUT} = 4.0V$ , $V_{ON} = V_{OUT}$ , $T_A = +25^\circ C$			0.22	
		$V_{IN} = 0V$ , $V_{OUT} = 4.0V$ , $V_{ON} = V_{OUT}$ , $T_A = +85^\circ C$			40	
<b>ON LOGIC</b>						
ON Logic-High Voltage	$V_{IH}$		1.4			V
ON Logic-Low Voltage	$V_{IL}$				0.6	V

# 0.075A to 1.5A, Programmable Current-Limit Switch

## ELECTRICAL CHARACTERISTICS (continued)

( $V_{IN} = 2.25V$  to  $4.5V$ ,  $C_{OUT} = 2.2\mu F$ ,  $T_A = -40^\circ C$  to  $+85^\circ C$ , unless otherwise noted. Typical values are at  $T_A = +25^\circ C$ , unless otherwise noted.) (Note 1)

PARAMETER	SYMBOL	CONDITIONS	MIN	TYP	MAX	UNITS
<b>FLAG OUTPUT LOGIC</b>						
FLAG Output Logic-Low Voltage	$V_{OL}$	$I_{SINK} = 1mA$			0.4	V
FLAG Output High Leakage Current		$V_{IN} = V_{FLAG} = 5.5V$			1	$\mu A$
<b>THERMAL PROTECTION</b>						
Thermal Shutdown		$V_{IN} = 3.3V$ , junction temperature rising		150		$^\circ C$
Thermal Shutdown Hysteresis		$V_{IN} = 3.3V$		15		$^\circ C$
<b>DYNAMIC</b>						
Turn-On Time (Note 3)	$T_{SS}$	$C_{SETS} = 0.01\mu F$	5	9	17.5	ms
Turn-Off Time	$T_{OFF}$	$V_{ON}$ from high to low; $R_L = 10\Omega$ , $R_{SET} = 0$ , $V_{IN} = 3.3V$		75	150	$\mu s$
Current-Limit Reaction Time		$V_{IN} = 4V$ , $R_{SET} = 0\Omega$ , output high and then short-circuit applied		1		$\mu s$
Blanking Time	$t_{BLANK}$	$C_{SETB} = 0.01\mu F$	3.5	6.75	11.5	ms
Retry Time			225	420	700	ms

**Note 1:** All parameters tested at  $T_A = +25^\circ C$ . Limits through the temperature range are guaranteed by design.

**Note 2:** Not production tested. Guaranteed by design.

**Note 3:** Turn-on time (also called soft-start time) is defined as the difference in the time between when the output crosses 10%, and 90% of the final output voltage.

## Typical Operating Characteristics

( $V_{IN} = 3.3V$ ,  $C_{OUT} = 2.2\mu F$ ,  $R_{SET1} = 0k\Omega$ ,  $T_A = +25^\circ C$ , unless otherwise noted.)

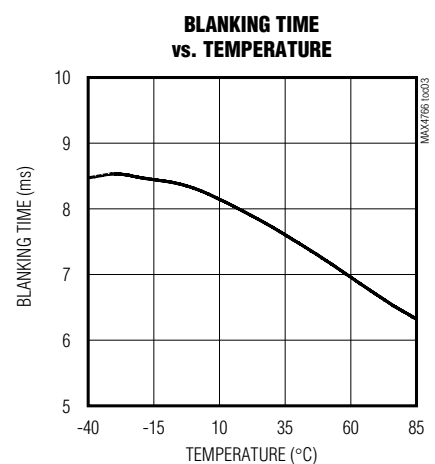
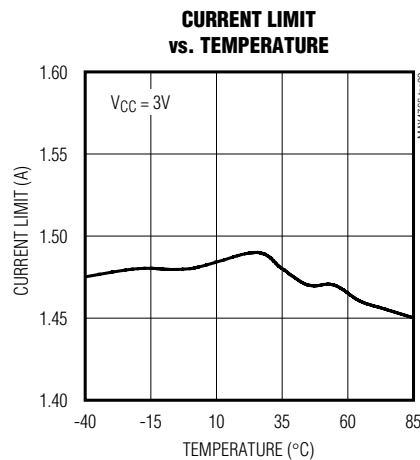
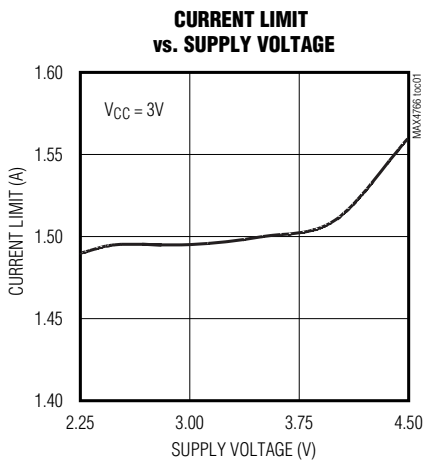

# 0.075A to 1.5A, Programmable Current-Limit Switch

MAX4766

## Typical Operating Characteristics (continued)

( $V_{IN} = 3.3V$ ,  $C_{OUT} = 2.2\mu F$ ,  $R_{SET1} = 0k\Omega$ ,  $T_A = +25^\circ C$ , unless otherwise noted.)

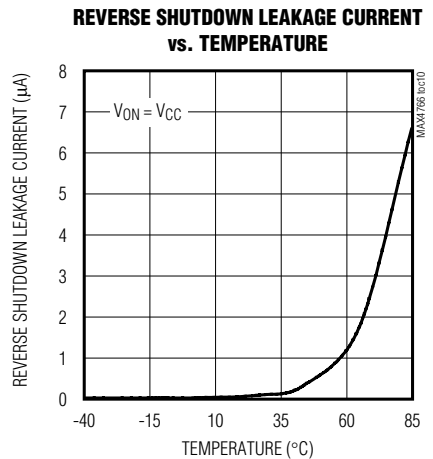
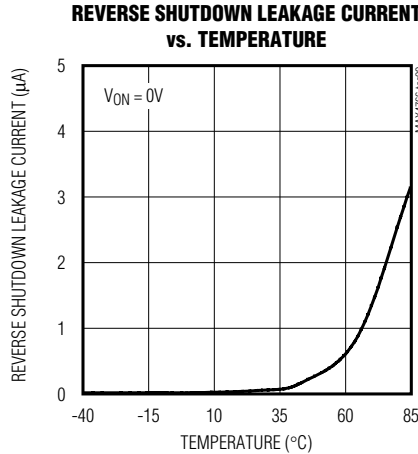
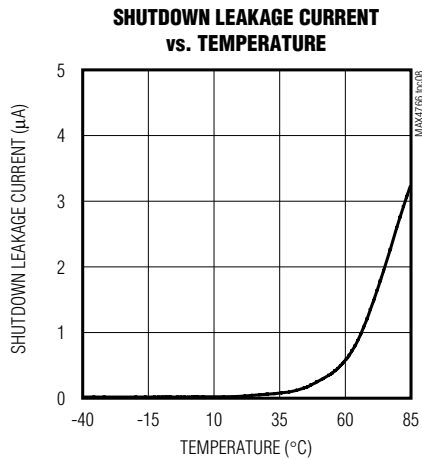
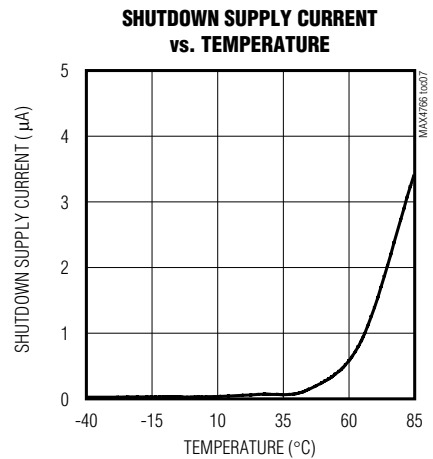
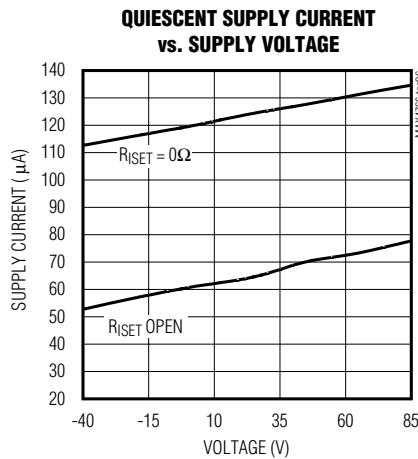
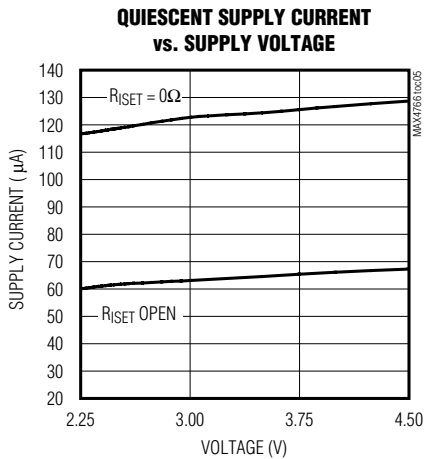
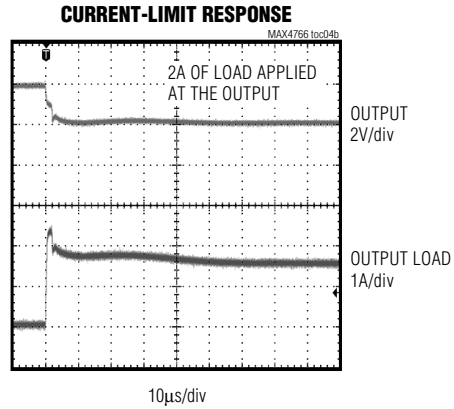
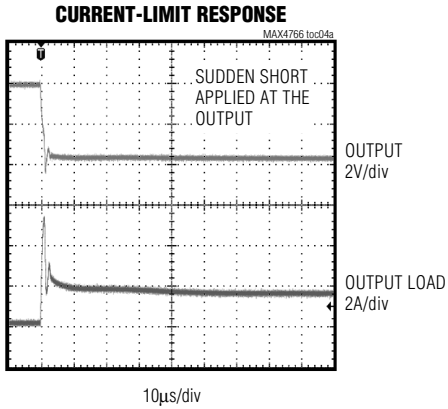

# 0.075A to 1.5A, Programmable Current-Limit Switch

## Typical Operating Characteristics (continued)

( $V_{IN} = 3.3V$ ,  $C_{OUT} = 2.2\mu F$ ,  $R_{SET1} = 0k\Omega$ ,  $T_A = +25^\circ C$ , unless otherwise noted.)

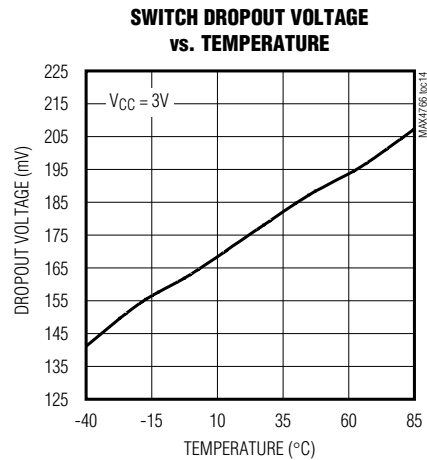
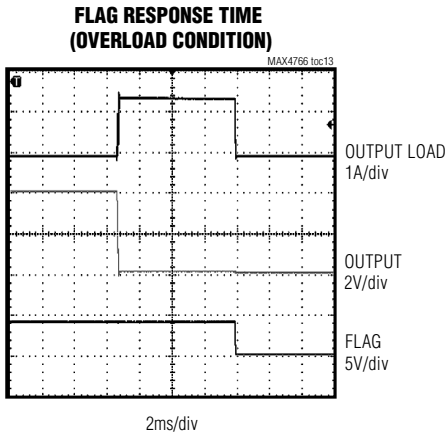
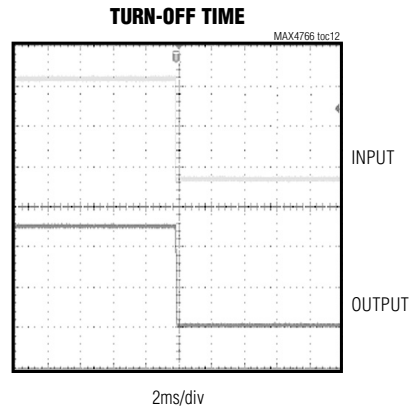
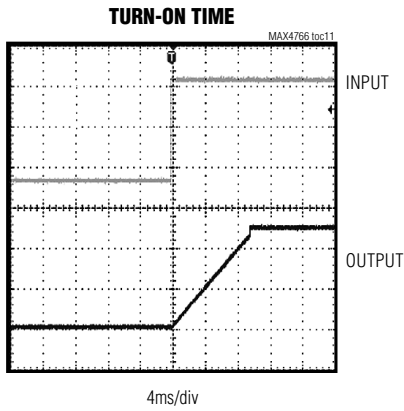

# 0.075A to 1.5A, Programmable Current-Limit Switch

## Pin Description

MAX4766

PIN		NAME	FUNCTION
MAX4766B/C	MAX4766A		
1	1	SETB	Blanking Time Adjust. Connect a capacitor from SETB to ground to program the blanking time. See the <i>Adjustable Blanking Time</i> section. Leave SETB floating to choose 1ms minimum preset blanking time.
2	—	$\overline{\text{FLAG}}$	Fault-Present-Indicator Output. $\overline{\text{FLAG}}$ is an open-drain output and goes low when the overload fault duration exceeds the blanking time, reverse current is detected, or the device is in thermal shutdown. Connect $\overline{\text{FLAG}}$ to IN with a 5k $\Omega$ resistor. For latch-off (MAX4766B) versions, the switch is turned off and $\overline{\text{FLAG}}$ output goes low after the blanking time. For the continuous version (MAX4766C), $\overline{\text{FLAG}}$ does not wait for the blanking time and goes low as soon as the current-limit threshold is reached.
—	2	N.C.	Not Connected
3	3	SETI	Current-Limit Adjust. To program the current limit, connect a resistor from SETI to ground. See the <i>Setting the Current Limit</i> Section for more detail. Shorting SETI to ground sets the device for maximum current limit of 1.5A.
4	4	OUT	Switch Output. Bypass OUT with a 2.2 $\mu\text{F}$ capacitor to ground.
5	5	IN	Power Input. Bypass IN with a 2.2 $\mu\text{F}$ or greater ceramic capacitor to ground. Larger capacitors may be needed to prevent large load transients from dragging down the supply voltage.
6	6	SETS	Soft-Start Adjust. Connect a capacitor from SETS to ground to program the soft-start time. See the <i>Adjustable Soft-Start</i> section. Leave SETS floating to choose 1ms minimum preset soft-start time.
7	7	ON	Active-High Switch On Input. Drive ON high to turn the switch on.
8	8	GND	Ground

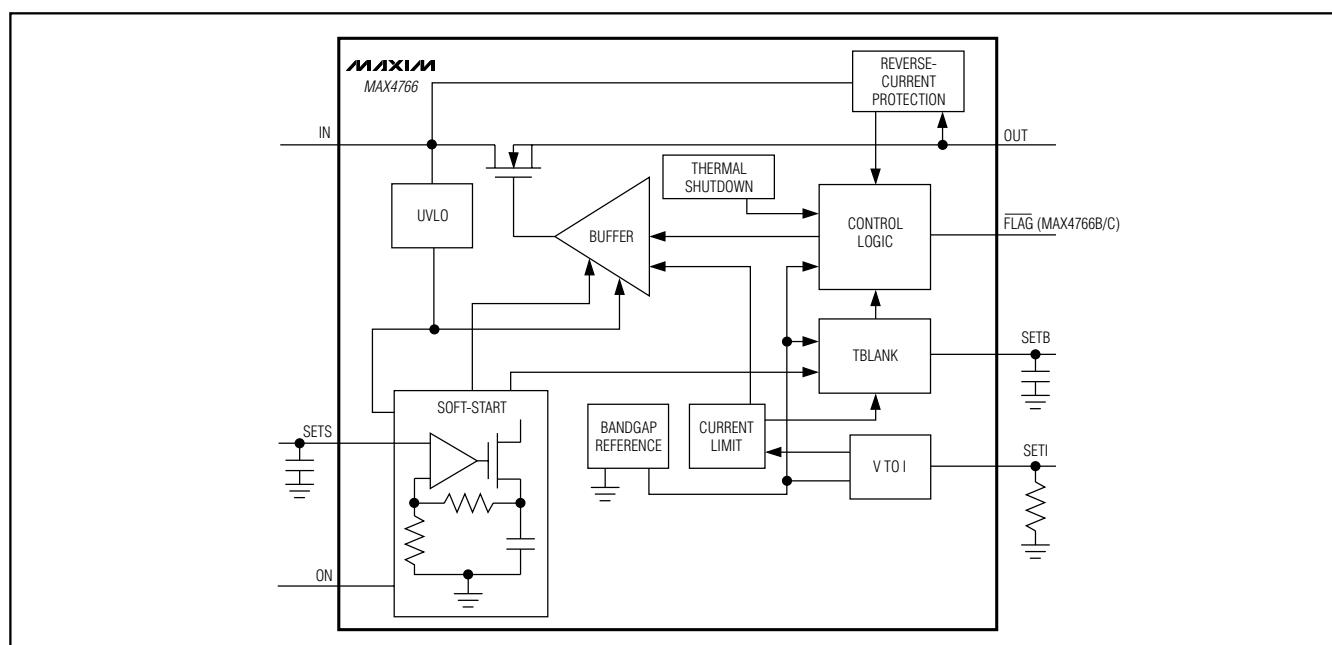

Figure 1. Functional Diagram

# 0.075A to 1.5A, Programmable Current-Limit Switch

## Detailed Description

The MAX4766 is a current-limit switch that operates from a 2.25V to 4.5V input voltage range and has a programmable current limit from 0.075A to 1.5A with a  $\pm 10\%$  accurate current limit. The device features an adjustable blanking time, an adjustable soft-start time, and an output indicator,  $\overline{\text{FLAG}}$ , that notifies the processor when a fault condition is present (Figure 1). The MAX4766 is available in latch-off, autoretry, and continuous current-limit versions (see the *Selector Guide*).

### Programmable Current Limit

A resistor from SET1 to GND programs the current limit for the switch (see the *Setting the Current Limit* section). The MAX4766 increases the pass transistor's gate drive when the programmed current-limit value is reached. If the load current exceeds the current limit for longer than the  $t_{\text{BLANK}}$  period, the switch either goes into autoretry, latches off, or stays in the continuous mode until the thermal limit is reached.

### Programmable Soft-Start

The MAX4766 features an adjustable soft-start time to control the output voltage ramp rate, thereby limiting the inrush surge current. An external capacitor from SETS to GND sets the soft-start time. The value of the capacitor directly determines the typical soft-start time. Use the following formula to determine the soft-start time:

$$\text{Soft-Start(ms)} = \frac{C_{\text{SETS}}}{1\text{nF}} \times 1\text{ms}$$

Leave SETS floating to choose 1ms minimum preset soft-start time.

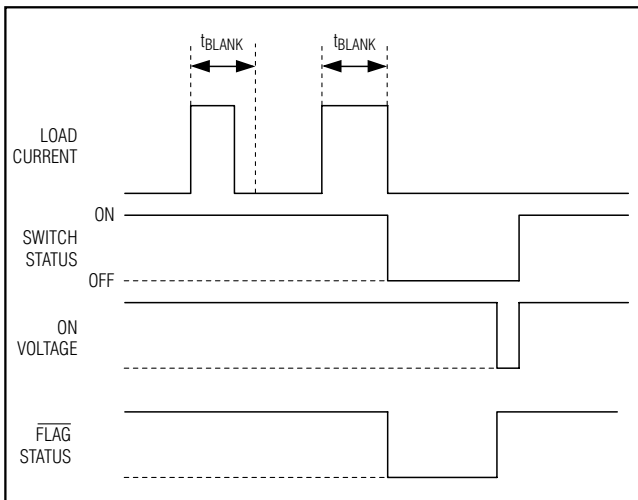

Figure 2a. Latch-Off Fault Blanking (Toggling ON)

## Programmable Blanking Time (MAX4766A/MAX4766B)

The adjustable fault-blanking time feature of the MAX4766 ensures that no fault signal asserts during power-up or when there is a momentary short caused by hot-swapping a capacitive load. An external capacitor from SETB to GND sets the blanking time. When a short or load transient causes the device to enter current limit, an internal counter monitors the duration of the fault after the soft-start time elapses. For the MAX4766B,  $\overline{\text{FLAG}}$  signal asserts low when load faults exceed the programmed blanking time ( $t_{\text{BLANK}}$ ). If the fault condition is removed before the programmed blanking time period has elapsed, the timer resets and the  $\overline{\text{FLAG}}$  signal does not assert (see Figures 2a and 2b). Only current-limit and short-circuit faults are blanked.

Table 1. Blanking Time vs. Capacitor Values

CSETB ( $\mu\text{F}$ )	TYPICAL BLANKING TIME (ms)
Open	1
0.01	8
0.025	19
0.05	35
0.075	50
0.1	65
0.125	80
0.150	100
0.175	115
0.2	125
0.25	150

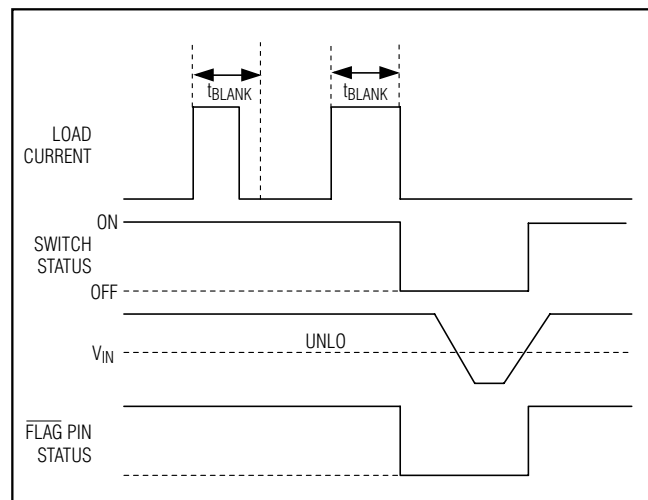

Figure 2b. Latch-Off Fault Blanking (Cycling IN Below UVLO)

## 0.075A to 1.5A, Programmable Current-Limit Switch

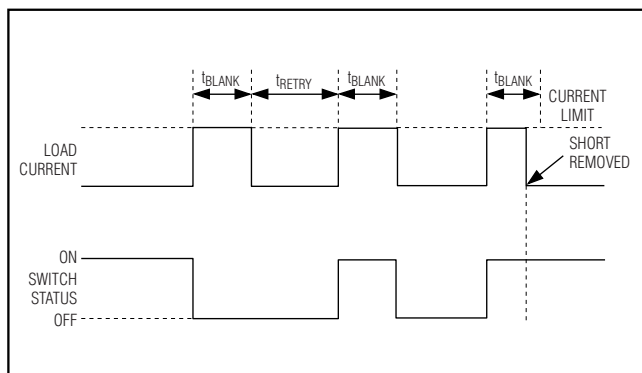

Figure 3. Autoretry Fault-Blanking Diagram

### Autoretry (MAX4766A)

When the forward current-limit threshold is exceeded, the  $t_{BLANK}$  timer begins counting (Figure 3). The timer resets if the overcurrent condition disappears before  $t_{BLANK}$  has elapsed. A retry time delay ( $t_{RETRY}$ ) starts immediately after  $t_{BLANK}$  has elapsed and during that time, the switch turns off. At the end of  $t_{RETRY}$ , the switch turns on again. If the fault still exists, the cycle repeats. If the fault has been removed, the switch stays on. The autoretry feature saves system power in the case of an overcurrent or short-circuit condition. During  $t_{BLANK}$ , when the switch is on, the supply current is at the current limit. During  $t_{RETRY}$ , when the switch is off, the current through the switch is zero. Instead of observing the full load current, the switch sees the equivalent load current times duty cycle or:

$$I_{SUPPLY} = I_{LOAD} \left( \frac{t_{BLANK}}{t_{BLANK} + t_{RETRY}} \right)$$

With a typical  $t_{BLANK} = 15\text{ms}$  and typical  $t_{RETRY} = 150\text{ms}$ , the duty cycle is 10%, which results in a 90% power savings over the switch being on the entire time.

### Continuous Current Limit

In the continuous current-limit version of the MAX4766, the output stays at the current limit until the output load reduces. In this case,  $\overline{FLAG}$  asserts as soon as there is current limit without waiting for blanking time and deasserts as soon as a short-circuit condition is removed. In this current mode, if the thermal power rating of the package is exceeded, the device will go into thermal shutdown and will not operate until the die temperature has cooled.

### Latch-Off

When the forward current-limit threshold is exceeded,  $t_{BLANK}$  timer begins counting. The timer resets if the overcurrent condition disappears before  $t_{BLANK}$  has elapsed. The switch turns off and  $\overline{FLAG}$  asserts if the overcurrent condition continues beyond the blanking time. Reset the switch by either toggling ON (Figure 2a) or cycling the input voltage (Figure 2b).

### Reverse-Current Protection

The MAX4766 features a reverse-current protection circuitry to limit the current back flow to  $1\mu\text{A}$  when the output voltage exceeds the input voltage by a  $100\text{mV}$ . During this period, the switch turns off and  $\overline{FLAG}$  asserts (MAX4766B/C) without waiting for  $t_{BLANK}$  time to elapse. If at this point the output voltage drops below input  $+100\text{mV}$ , the switch turns on and  $\overline{FLAG}$  deasserts (MAX4766B/C).

### Thermal Shutdown

A thermal-shutdown circuitry protects the devices from overheating. The switch turns off and  $\overline{FLAG}$  goes (MAX4766B/C) low immediately (no fault blanking) when the junction temperature exceeds  $+150^\circ\text{C}$ . The MAX4766B (latch-off) does not turn on again until ON is cycled from high to low to high. The MAX4766A (autoretry) and the MAX4766C (continuous) turn the switch on again after the device temperature drops approximately  $+15^\circ\text{C}$ .

### $\overline{FLAG}$ Indicator

$\overline{FLAG}$  is an open-drain fault indicator output and requires an external pullup resistor to a DC supply (usually IN).  $\overline{FLAG}$  goes low when any of the following conditions occur:

- The device is in current limit for more than the fault-blanking period in the case of MAX4766B.
- The device is in current limit in the case of MAX4766C (no blanking time).
- The switch is in autoretry mode.
- The OUT voltage is above the IN voltage by more than  $100\text{mV}$ .
- The die temperature exceeds the thermal-shutdown temperature limit of the  $+15^\circ\text{C}$ .

## 0.075A to 1.5A, Programmable Current-Limit Switch

**Table 2. Current Limit vs. Resistor Values**

R <sub>SETI</sub> (kΩ)	TYPICAL CURRENT LIMIT (A)
1500	0.075
1125	0.1
750	0.15
562.5	0.2
330	0.375
200.9	0.56
150	0.75
112.5	1.0
90	1.25
80.35	1.4
≤75	1.5

### Applications Information

#### Setting the Current Limit

A resistor from SETI to ground programs the current-limit value for the MAX4766. Table 2 lists various current limits set by different resistor values. Use the following formula to calculate the current limit:

$$R_{SETI} = \left( \frac{112.5kV}{I_{LIM(A)}} \right) k\Omega$$

#### Input Capacitor

Connect a capacitor from IN to ground to limit the input voltage drop during momentary output short-circuit conditions. A 2.2μF ceramic capacitor with less than 0.2Ω ESR is adequate for most applications. Higher capacitor values further reduce the voltage drop at the input.

#### Output Capacitor

For stable operation over the full temperature range and over the full-programmable current-limit range, use a 2.2μF capacitor with less than 0.2Ω ESR from OUT to ground.

If the load capacitance is too large, then current may not have enough time to charge the capacitance and the device assumes that there is a faulty load condition. The maximum capacitive load value that can be driven from OUT is obtained by the following formula:

$$C_{MAX} = \left( \frac{I_{FWD\_MIN} \times t_{BLANK}}{V_{IN}} \right)$$

#### Layout and Thermal Dissipation

To optimize the switch response time to output short-circuit conditions, it is very important to keep all traces as short as possible to reduce the effect of undesirable parasitic inductance. Place input and output capacitors as close as possible to the device (no more than 5mm). IN and OUT pins must be connected with short traces to the power bus. During normal operation, the power dissipation is small and the package temperature change is minimal. If the output is continuously shorted to ground at the maximum supply voltage, the operation of the switches with the autoretry option does not cause problems because the total power dissipated during the short is scaled by the duty cycle:

$$P_{MAX} = \left( \frac{V_{IN\_MAX} \times I_{OUT\_MAX} \times t_{BLANK}}{t_{RETRY} + t_{BLANK}} \right)$$

Attention must be given to the latch-off version of the MAX4766 where the latch-off condition must be manually reset by toggling ON from high to low. If the latch-off time duration is not sufficiently high, it is possible for the device to reach the thermal shutdown threshold and never be able to turn the device on until it cools down.

### Chip Information

TRANSISTOR COUNT: 1544

PROCESS: CMOS

# 0.075A to 1.5A, Programmable Current-Limit Switch

## Package Information

(The package drawing(s) in this data sheet may not reflect the most current specifications. For the latest package outline information, go to [www.maxim-ic.com/packages](http://www.maxim-ic.com/packages).)

**MAX4766**

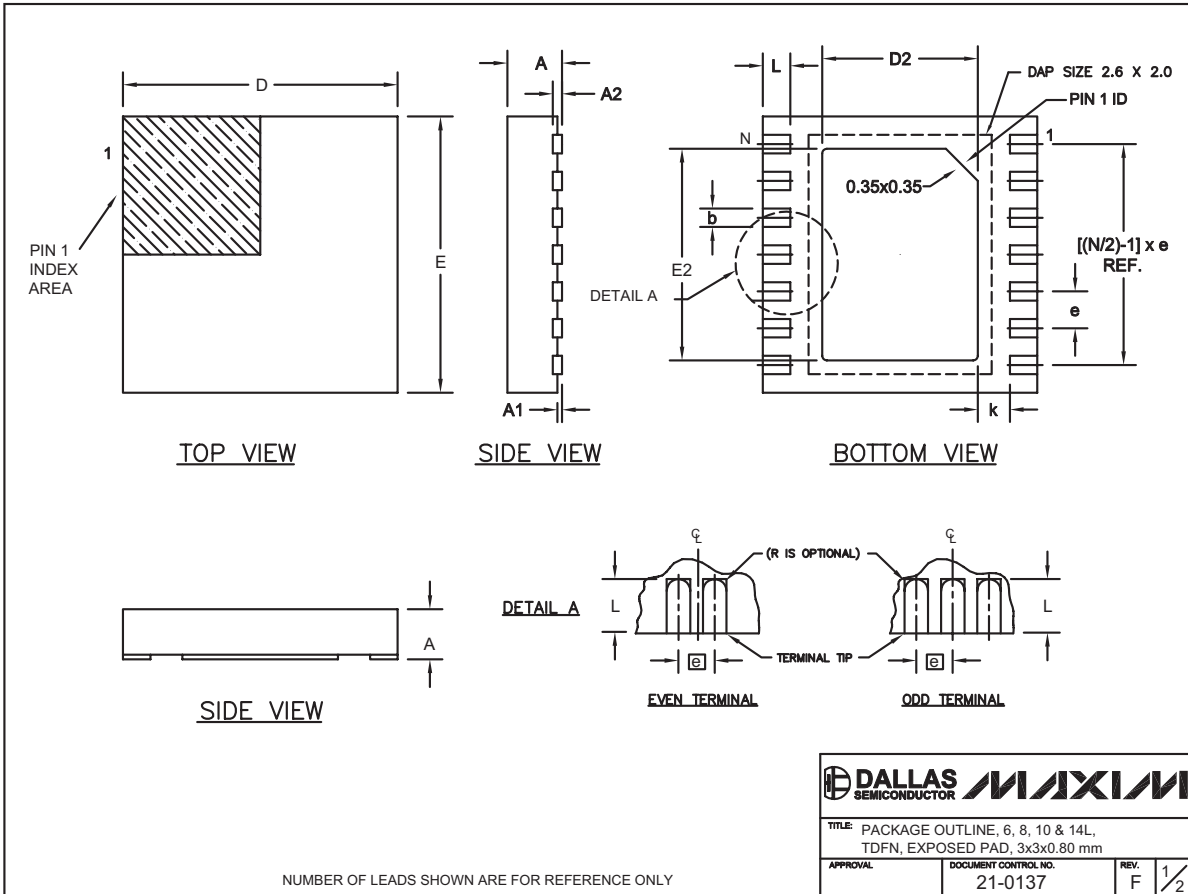

# 0.075A to 1.5A, Programmable Current-Limit Switch

## Package Information (continued)



(The package drawing(s) in this data sheet may not reflect the most current specifications. For the latest package outline information, go to [www.maxim-ic.com/packages](http://www.maxim-ic.com/packages).)

COMMON DIMENSIONS		
SYMBOL	MIN.	MAX.
A	0.70	0.80
D	2.90	3.10
E	2.90	3.10
A1	0.00	0.05
L	0.20	0.40
k	0.25 MIN.	
A2	0.20 REF.	

PACKAGE VARIATIONS							
PKG. CODE	N	D2	E2	e	JEDEC SPEC	b	[(N/2)-1] x e
T633-1	6	1.50±0.10	2.30±0.10	0.95 BSC	MO229 / WEEA	0.40±0.05	1.90 REF
T833-1	8	1.50±0.10	2.30±0.10	0.65 BSC	MO229 / WEEC	0.30±0.05	1.95 REF
T1033-1	10	1.50±0.10	2.30±0.10	0.50 BSC	MO229 / WEED-3	0.25±0.05	2.00 REF
T1433-1	14	1.70±0.10	2.30±0.10	0.40 BSC	----	0.20±0.03	2.40 REF
T1433-2	14	1.70±0.10	2.30±0.10	0.40 BSC	----	0.20±0.03	2.40 REF

### NOTES:

- ALL DIMENSIONS ARE IN mm. ANGLES IN DEGREES.
- COPLANARITY SHALL NOT EXCEED 0.08 mm.
- WARPAGE SHALL NOT EXCEED 0.10 mm.
- PACKAGE LENGTH/PACKAGE WIDTH ARE CONSIDERED AS SPECIAL CHARACTERISTIC(S).
- DRAWING CONFORMS TO JEDEC MO229, EXCEPT DIMENSIONS "D2" AND "E2", AND T1433-1 & T1433-2.
- "N" IS THE TOTAL NUMBER OF LEADS.

 	
TITLE: PACKAGE OUTLINE, 6, 8, 10 & 14L, TDFN, EXPOSED PAD, 3x3x0.80 mm	
APPROVAL	DOCUMENT CONTROL NO. 21-0137
REV.	F 2/2

Maxim cannot assume responsibility for use of any circuitry other than circuitry entirely embodied in a Maxim product. No circuit patent licenses are implied. Maxim reserves the right to change the circuitry and specifications without notice at any time.

12 \_\_\_\_\_ **Maxim Integrated Products, 120 San Gabriel Drive, Sunnyvale, CA 94086 408-737-7600**

## Looking for pricing, stock, or lifecycle information?

Click below to explore more details on WIN SOURCE:

- ⊖ [View MAX4766CETA+TG47 on WIN SOURCE](#)
- ⊖ [Maxim Integrated Information](#)

## Optimize Your Supply Chain with WIN SOURCE Solutions

- ✓ Global Sourcing Solution
- ✓ Obsolete Management
- ✓ Cost Control Management
- ✓ Shortage Management
- ✓ Alternative Solution
- ✓ Excess Inventory Management