



**THE DATASHEET OF
MAX4638ETE+**



3.5Ω, Single 8:1 and Dual 4:1, Low-Voltage Analog Multiplexers

General Description

The MAX4638/MAX4639 are single 8:1 and dual 4:1 CMOS analog multiplexers/demultiplexers (muxes/demuxes). Each mux operates from a single +1.8V to +5V supply or dual ±2.5V supplies. These devices feature 3.5Ω on-resistance (R_{ON}) when powered with a single +5V supply and have -75dB off-isolation and -85dB crosstalk from the output to each off channel. The switching times are 18ns t_{ON} and 7ns t_{OFF} . They feature a -3dB 85MHz bandwidth and a guaranteed 0.25nA leakage current at +25°C.

A +1.8V to +5.5V operating range makes the MAX4638/MAX4639 ideal for battery-powered, portable instruments. All channels guarantee break-before-make switching. These parts feature bidirectional operation and can handle Rail-to-Rail® analog signals. All control inputs are TTL/CMOS-logic compatible. Decoding is in standard BCD format, and an enable input is provided to simplify cascading of devices. These devices are available in small 16-pin TQFN, TSSOP, and SO packages, as well as a 20-pin TQFN package.

Applications

- Automatic Test Equipment
- Low-Voltage Data-Acquisition Systems
- Audio and Video Signal Routing
- Medical Equipment
- Battery-Powered Equipment
- Relay Replacement

Features

- ◆ **Guaranteed R_{ON}**
3.5Ω (+5V or ±2.5V Supplies)
6Ω (+3V Supply)
- ◆ **Guaranteed 0.4Ω R_{ON} Match Between Channels**
- ◆ **Guaranteed 1Ω R_{ON} Flatness Over Signal Range**
- ◆ **Guaranteed Low Leakage Currents**
0.25nA at +25°C
- ◆ **Switching Times: t_{ON} = 18ns, t_{OFF} = 7ns**
- ◆ **+1.8V to +5.5V Single-Supply Operation**
±2.5V Dual-Supply Operation
- ◆ **Rail-to-Rail Signal Handling**
- ◆ **TTL/CMOS-Logic Compatible**
- ◆ **Crosstalk: -80dB (1MHz)**
- ◆ **Off-Isolation: -60dB (10MHz)**

Ordering Information

PART	TEMP RANGE	PIN-PACKAGE
MAX4638ETE+T	-40°C to +85°C	16 TQFN-EP* (4 × 4)
MAX4638EUE+T	-40°C to +85°C	16 TSSOP
MAX4638ESE+T	-40°C to +85°C	16 SO
MAX4638ETP+T	-40°C to +85°C	20 TQFN-EP* (4 × 4)

+Denotes a lead(Pb)-free/RoHS-compliant package.

T = Tape and reel.

*EP = Exposed pad.

Ordering Information continued at end of data sheet.

Pin Configurations/Functional Diagrams

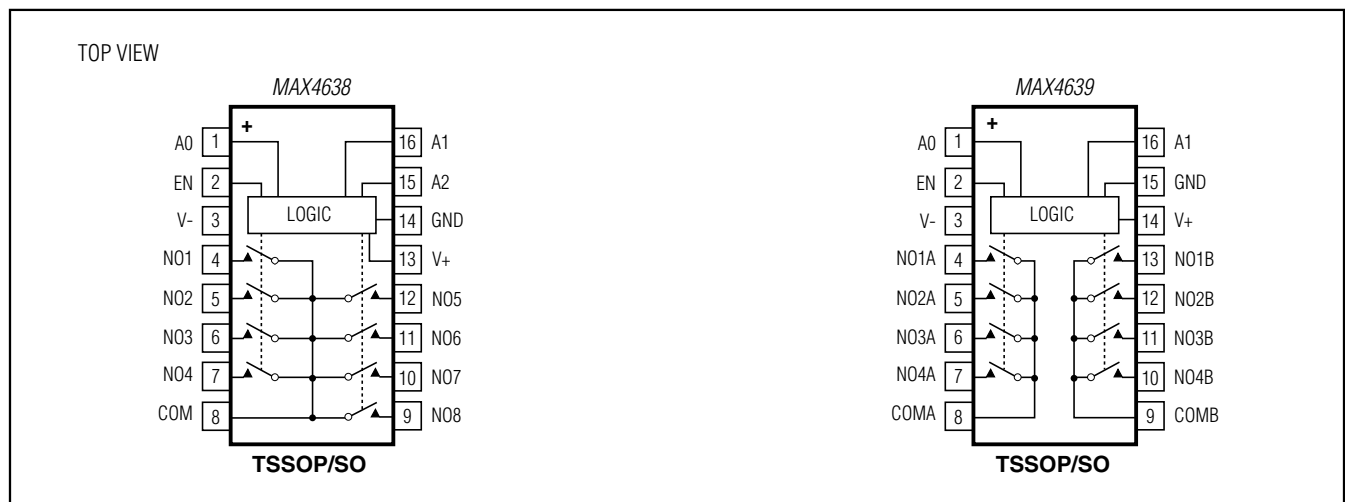

Rail-to-Rail is a registered trademark of Nippon Motorola, Ltd.

For pricing, delivery, and ordering information, please contact Maxim Direct at 1-888-629-4642, or visit Maxim Integrated's website at www.maximintegrated.com.

MAX4638/MAX4639

3.5Ω, Single 8:1 and Dual 4:1, Low-Voltage Analog Multiplexers

ABSOLUTE MAXIMUM RATINGS

(Voltages Referenced to GND)

V+ to V-	+6V
V+, A_, EN	-0.3V to +6V
V-	+0.3V to -6V
NO_, COM_ (Note 1)	-0.3V to (V+ + 0.3V)
Continuous Current A_, EN	±30mA
Continuous Current NO_, COM_	±100mA
Peak Current (NO_, COM_) (pulsed at 1ms, 10% duty cycle)	±200mA

Continuous Power Dissipation (T_A = +70°C)

TQFN (derate 16.9mW/°C above +70°C)	1349mW
TSSOP (derate 9.4mW/°C above +70°C)	754.7mW
SO (derate 8.70mW/°C above +70°C)	696mW
Operating Temperature Range	
MAX463_E_E	-40°C to +85°C
Junction Temperature	+150°C
Storage Temperature Range	-65°C to +150°C
Lead Temperature (soldering, 10s)	+300°C
Soldering Temperature (reflow)	+260°C

Note 1: Signals on COM_, NO_ exceeding V+ or V- are clamped by internal diodes. A_ and EN are clamped only to V- and can exceed V+ up to their maximum ratings. Limit forward-diode current to maximum current rating.

Stresses beyond those listed under "Absolute Maximum Ratings" may cause permanent damage to the device. These are stress ratings only, and functional operation of the device at these or any other conditions beyond those indicated in the operational sections of the specifications is not implied. Exposure to absolute maximum rating conditions for extended periods may affect device reliability.

ELECTRICAL CHARACTERISTICS—+5V Single Supply

(V+ = +5V ±10%, V- = 0, V_{IH} = +2.4V, V_{IL} = +0.8V, T_A = T_{MIN} to T_{MAX}, unless otherwise noted. Typical values are at T_A = +25°C.) (Notes 2, 3)

PARAMETER	SYMBOL	CONDITIONS	MIN	TYP (Note 2)	MAX	UNITS		
ANALOG SWITCH								
Analog Signal Range	V _{COM_} , V _{NO_}		0		V+	V		
On-Resistance	R _{ON}	V+ = +4.5V, I _{COM_} = 10mA, V _{NO_} = +3.5V	T _A = +25°C		2.5	3.5	Ω	
			T _A = T _{MIN} to T _{MAX}			4.5		
On-Resistance Match Between Channels (Notes 4, 5)	ΔR _{ON}	V+ = +4.5V, I _{COM_} = 10mA, V _{NO_} = +3.5V	T _A = +25°C		0.1	0.4	Ω	
			T _A = T _{MIN} to T _{MAX}			0.5		
On-Resistance Flatness (Note 6)	R _{FLAT(ON)}	V+ = +4.5V; I _{COM_} = 10mA; V _{NO_} = +1V, +2V, +3.5V	T _A = +25°C		0.75	1	Ω	
			T _A = T _{MIN} to T _{MAX}			1.2		
NO_ Off-Leakage Current (Note 7)	I _{NO_(OFF)}	V+ = +5.5V; V _{COM_} = +1V, +4.5V; V _{NO_} = +4.5V, +1V	T _A = +25°C		-0.25	±0.01	0.25	nA
			T _A = T _{MIN} to T _{MAX}		-0.35		0.35	
COM_ Off-Leakage Current (Note 7)	I _{COM_(OFF)}	V+ = +5.5V; V _{COM_} = +1V, +4.5V; V _{NO_} = +4.5V, +1V	T _A = +25°C		-0.25	±0.01	0.25	nA
			T _A = T _{MIN} to T _{MAX}		-0.75		0.75	
COM_ On-Leakage Current (Note 7)	I _{COM_(ON)}	V+ = +5.5V; V _{COM_} = +1V, +4.5V; V _{NO_} = +1V, +4.5V, or unconnected	T _A = +25°C		-0.25	±0.01	0.25	nA
			T _A = T _{MIN} to T _{MAX}		-0.75		0.75	
DIGITAL I/O								
Input Logic High	V _{IH}		2.4			V		
Input Logic Low	V _{IL}				0.8	V		
Input Leakage Current	I _{IH} , I _{IL}	V _{IN_} = 0 or V+	-0.1	0.005	0.1	μA		
Digital Input Capacitance	C _{IN}		2			pF		
DYNAMIC								
Transition Time (Note 7)	t _{TRANS}	R _L = 100Ω, C _L = 35pF, V _{NO1} = +3V or 0, V _{NO8} = 0 or +3V, Figure 2	T _A = +25°C		14	18	ns	
			T _A = T _{MIN} to T _{MAX}			20		

MAX4638/MAX4639

3.5Ω, Single 8:1 and Dual 4:1, Low-Voltage Analog Multiplexers

ELECTRICAL CHARACTERISTICS—+5V Single Supply (continued)

(V+ = +5V ±10%, V- = 0, V_{IH} = +2.4V, V_{IL} = +0.8V, T_A = T_{MIN} to T_{MAX}, unless otherwise noted. Typical values are at T_A = +25°C.) (Notes 2, 3)

PARAMETER	SYMBOL	CONDITIONS		MIN	TYP (Note 2)	MAX	UNITS
Break-Before-Make (Note 7)	t _{BBM}	R _L = 100Ω, C _L = 35pF, V _{NO-} = +3V, Figure 3	MAX4638	T _A = +25°C	8		ns
				T _A = T _{MIN} to T _{MAX}	1		
Enable Turn-On Time (Note 7)	t _{ON(EN)}	R _L = 100Ω, C _L = 35pF, V _{NO1} = +3V, V _{NO2} to V _{NO8} = 0, Figure 4	MAX4638	T _A = +25°C	14	18	ns
				T _A = T _{MIN} to T _{MAX}		20	
Enable Turn-Off Time (Note 7)	t _{OFF(EN)}	R _L = 100Ω, C _L = 35pF, V _{NO1} = +3V, V _{NO2} to V _{NO8} = 0, Figure 4	MAX4638	T _A = +25°C	5	7	ns
				T _A = T _{MIN} to T _{MAX}		8	
On-Channel -3dB Bandwidth	BW	Signal = 0dBm, C _L = 5pF, 50Ω in and out, Figure 6	MAX4638	T _A = +25°C	50		MHz
			MAX4639	T _A = +25°C	85		
Charge Injection	Q	V _{GEN} = +2.5V, R _{GEN} = 0, C _L = 1.0nF, Figure 5	MAX4638	T _A = +25°C	13		pC
NO_ Off-Capacitance	C _{NO_(OFF)}	V _{NO-} = 0V, f = 1MHz, Figure 8	MAX4638	T _A = +25°C	9		pF
COM_ Off-Capacitance	C _{COM_(OFF)}	V _{COM-} = 0V, f = 1MHz, Figure 8	MAX4638	T _A = +25°C	40		pF
			MAX4639	T _A = +25°C	20		
Switch On-Capacitance	C _(ON)	V _{COM-} = V _{NO-} = 0V, f = 1MHz, Figure 8	MAX4638	T _A = +25°C	54		pF
			MAX4639	T _A = +25°C	34		
Off-Isolation (Note 8)	V _{ISO}	C _L = 5pF, R _L = 50Ω, f = 1MHz, V _{NO-} = 1V _{RMS} , Figure 6	MAX4638	T _A = +25°C	-55		dB
				T _A = +25°C	-75		
Crosstalk (Note 9)	V _{CT}	C _L = 5pF, R _L = 50Ω, f = 10MHz, V _{NO-} = 1V _{RMS} , Figure 7	MAX4638	T _A = +25°C	-65		dB
				T _A = +25°C	-85		
Total Harmonic Distortion	THD	R _L = 600Ω, R _{FLAT(ON)} /R _L	MAX4638	T _A = +25°C	0.5		%
SUPPLY							
Positive Supply Current	I+	V+ = +5.5V, V _{IN} = 0 or V+	MAX4638	T _A = +25°C	0.001	1.0	μA

MAX4638/MAX4639

MAX4638/MAX4639

3.5Ω, Single 8:1 and Dual 4:1, Low-Voltage Analog Multiplexers

ELECTRICAL CHARACTERISTICS—+3.0V Single Supply

(V+ = +2.7V to +3.3V, V- = 0, VIH = +2.0V, VIL = +0.4V, TA = TMIN to TMAX, unless otherwise noted. Typical values are at V+ = +3V and TA = +25°C.) (Notes 2, 3)

PARAMETER	SYMBOL	CONDITIONS		MIN	TYP (Note 2)	MAX	UNITS
ANALOG SWITCH							
Analog Signal Range	VCOM_, VNO_			0		V+	V
On-Resistance	RON	ICOM_ = 10mA, VNO_ = +1.7V	TA = +25°C	4.5	6		Ω
			TA = TMIN to TMAX			8	
On-Resistance Match Between Channels (Notes 4, 5)	ΔRON	ICOM_ = 10mA, VNO_ = +1.7V	TA = +25°C	0.25	0.6		Ω
			TA = TMIN to TMAX			0.8	
On-Resistance Flatness (Note 6)	RFLAT(ON)	ICOM_ = 10mA; VNO_ = +1.5V, +1.7V, +1.9V	TA = +25°C	1	2		Ω
			TA = TMIN to TMAX			2.5	
NO_ Off-Leakage Current (Note 7)	INO_(OFF)	V+ = +3.3V; VCOM_ = +1V, +3V; VNO_ = +3V, +1V	TA = +25°C	-0.25	±0.01	0.25	nA
			TA = TMIN to TMAX	-0.35		0.35	
COM_ Off-Leakage Current (Note 7)	ICOM_(OFF)	V+ = +3.3V; VCOM_ = +1V, +3V; VNO_ = +3V, +1V	TA = +25°C	-0.25	±0.01	0.25	nA
			TA = TMIN to TMAX	-0.35		0.35	
COM_ On-Leakage Current (Note 7)	ICOM_(ON)	V+ = +3.3V; VCOM_ = +1V, +3V; VNO_ = +1V, +3V, or unconnected	TA = +25°C	-0.25	±0.01	0.25	nA
			TA = TMIN to TMAX	-0.35		0.35	
DIGITAL I/O							
Input Logic High	VIH			2.0			V
Input Logic Low	VIL					0.4	V
Input Leakage Current	I _{IH} , I _{IL}	VIN_ = 0 or V+		-0.1	0.005	0.1	μA
Digital Input Capacitance	CIN				2		pF
DYNAMIC							
Transition Time (Note 7)	tTRANS	VNO_ = +2V, CL = 35pF, RL = 100Ω, Figure 2	TA = +25°C	16	20		ns
			TA = TMIN to TMAX			24	
Break-Before-Make (Note 7)	tBBM	VNO_ = +2V, CL = 35pF, RL = 100Ω, Figure 3	TA = +25°C	8			ns
			TA = TMIN to TMAX	1			
Enable Turn-On Time (Note 7)	tON(EN)	VNO_ = +2V, CL = 35pF, RL = 100Ω, Figure 4	TA = +25°C	15	20		ns
			TA = TMIN to TMAX			24	
Enable Turn-Off Time (Note 7)	tOFF(EN)	VNO_ = +2V, CL = 35pF, RL = 100Ω, Figure 4	TA = +25°C	5	9		ns
			TA = TMIN to TMAX			10	

MAX4638/MAX4639

3.5Ω, Single 8:1 and Dual 4:1, Low-Voltage Analog Multiplexers

ELECTRICAL CHARACTERISTICS—+3.0V Single Supply (continued)

(V+ = +2.7V to +3.3V, V- = 0, V_{IH} = +2.0V, V_{IL} = +0.4V, T_A = T_{MIN} to T_{MAX}, unless otherwise noted. Typical values are at V+ = +3V and T_A = +25°C.) (Notes 2, 3)

PARAMETER	SYMBOL	CONDITIONS		MIN	TYP (Note 2)	MAX	UNITS
Off-Isolation (Note 8)	V _{ISO}	C _L = 5pF, R _L = 50Ω, f = 10MHz, V _{NO-} = +1V _{RMS} , Figure 6	T _A = +25°C		55		dB
		C _L = 5pF, R _L = 50Ω, f = 1MHz, V _{NO-} = 1V _{RMS} , Figure 6	T _A = +25°C		-75		
Crosstalk (Note 9)	V _{CT}	C _L = 5pF, R _L = 50Ω, f = 10MHz, V _{NO-} = 1V _{RMS} , Figure 7	T _A = +25°C		-65		dB
		C _L = 5pF, R _L = 50Ω, f = 1MHz, V _{NO-} = 1V _{RMS} , Figure 7	T _A = +25°C		-85		
On-Channel -3dB Bandwidth	BW	Signal = 0dBm, 50Ω in and out, Figure 6	MAX4638	T _A = +25°C	50		MHz
			MAX4639	T _A = +25°C	85		
NO- Off-Capacitance	C _{NO-(OFF)}	V _{NO-} = 0V, f = 1MHz, Figure 8	T _A = +25°C		9		pF
COM- Off-Capacitance	C _{COM-(OFF)}	V _{COM-} = 0V, f = 1MHz, Figure 8	MAX4638	T _A = +25°C	40		pF
			MAX4639	T _A = +25°C	20		
Switch On-Capacitance	C _(ON)	V _{COM-} = V _{NO-} = 0V, f = 1MHz, Figure 8	MAX4638	T _A = +25°C	54		pF
			MAX4639	T _A = +25°C	34		
SUPPLY							
Positive Supply Current	I+	V+ = +3.3V, V _{IN-} = 0 or V+			0.001	1	μA

ELECTRICAL CHARACTERISTICS—±2.5V Dual Supplies

(V+ = +2.5 ±10%, V- = -2.5 ±10%, V_{IH} = +2.0V, V_{IL} = +0.4V, T_A = T_{MIN} to T_{MAX}, unless otherwise noted. Typical values are at V± = ±2.5V and T_A = +25°C.) (Notes 2, 3)

PARAMETER	SYMBOL	CONDITIONS		MIN	TYP (Note 2)	MAX	UNITS
ANALOG SWITCH							
Analog Signal Range	V _{COM-} , V _{NO-}			V-		V+	V
On-Resistance	R _{ON}	I _{COM-} = 10mA, V _{NO-} = ±1.5V, V+ = +2.25V, V- = -2.25V	T _A = +25°C		2.5	3.5	Ω
			T _A = T _{MIN} to T _{MAX}			4.5	
On-Resistance Match Between Channels (Notes 4, 5)	ΔR _{ON}	I _{COM-} = 10mA, V _{NO-} = ±1.5V, V+ = +2.25V, V- = -2.25V	T _A = +25°C		0.2	0.4	Ω
			T _A = T _{MIN} to T _{MAX}			0.5	

MAX4638/MAX4639

3.5Ω, Single 8:1 and Dual 4:1, Low-Voltage Analog Multiplexers

ELECTRICAL CHARACTERISTICS—±2.5V Dual Supplies (continued)

(V+ = +2.5 ±10%, V- = -2.5V ±10%, VIH = +2.0V, VIL = +0.4V, TA = TMIN to TMAX, unless otherwise noted. Typical values are at V± = ±2.5V and TA = +25°C.) (Notes 2, 3)

PARAMETER	SYMBOL	CONDITIONS	MIN	TYP (Note 2)	MAX	UNITS	
On-Resistance Flatness (Note 6)	R _{FLAT(ON)}	I _{COM_} = 10mA; V _{NO_} = ±1.5V, 0; V+ = +2.25V; V- = -2.25V	TA = +25°C	0.75	1	Ω	
			TA = T _{MIN} to T _{MAX}		1.2		
NO_ Off-Leakage Current (Note 7)	I _{NO_ (OFF)}	V+ = +2.75V; V- = -2.75V; V _{COM_} = +1V, +2.5V; V _{NO_} = +2.5V, +1V	TA = +25°C	-0.25	±0.01	0.25	nA
			TA = T _{MIN} to T _{MAX}	-0.35		0.35	
COM_ Off-Leakage Current (Note 7)	I _{COM_ (OFF)}	V+ = +2.75V; V- = -2.75V; V _{COM_} = +1V, +2.5V; V _{NO_} = +2.5V, +1V	TA = +25°C	-0.25	±0.01	0.25	nA
			TA = T _{MIN} to T _{MAX}	-0.35		0.35	
COM_ On-Leakage Current (Note 7)	I _{COM_ (ON)}	V+ = +2.5V; V- = -2.5V; V _{COM_} = +1V, +2.5V; V _{NO_} = +1V, +2.5V, or unconnected	TA = +25°C	-0.25	±0.01	0.25	nA
			TA = T _{MIN} to T _{MAX}	-0.35		0.35	
DIGITAL I/O							
Input Logic High	VIH		2.0			V	
Input Logic Low	VIL				0.4	V	
Input Leakage Current	I _{IH, IIL}	V _{IN_} = 0 or V+	-0.1	0.005	0.1	μA	
Digital Input Capacitance	C _{IN}			2		pF	
DYNAMIC							
Transition Time (Note 7)	t _{TRANS}	V _{NO_} = +1.2V, C _L = 35pF, R _L = 100Ω, Figure 2	TA = +25°C	16	20	ns	
			TA = T _{MIN} to T _{MAX}		24		
Enable Turn-On Time (Note 7)	t _{ON(EN)}	V _{NO_} = +1.2V, C _L = 35pF, R _L = 100Ω, Figure 4	TA = +25°C	14	18	ns	
			TA = T _{MIN} to T _{MAX}		20		
Enable Turn-Off Time (Note 7)	t _{OFF(EN)}	V _{NO_} = +1.2V, C _L = 35pF, R _L = 100Ω, Figure 4	TA = +25°C	5	7	ns	
			TA = T _{MIN} to T _{MAX}		8		
Break-Before-Make (Note 7)	t _{BBM}	V _{NO_} = +1.2V, C _L = 35pF, R _L = 100Ω, Figure 3	TA = +25°C	8		ns	
			TA = T _{MIN} to T _{MAX}	1			

Note 2: The algebraic convention, where the most negative value is a minimum and the most positive value a maximum, is used in this data sheet.

Note 3: Parts are tested at +85°C and guaranteed by design over the entire temperature range.

Note 4: ΔRON = RON(MAX) - RON(MIN).

Note 5: ΔRON matching specifications for TQFN packaged parts are guaranteed by design.

Note 6: Flatness is defined as the difference between the maximum and minimum value of on-resistance as measured over the specified analog signal ranges.

Note 7: Guaranteed by design.

Note 8: Off-Isolation = 20log₁₀ (V_{COM_} / V_{NO_}), V_{COM_} = output, V_{NO_} = input to off switch.

Note 9: Between any two switches.

MAX4638/MAX4639

3.5Ω, Single 8:1 and Dual 4:1, Low-Voltage Analog Multiplexers

Typical Operating Characteristics

(V+ = +5V, V- = 0V, T_A = +25°C, unless otherwise noted.)

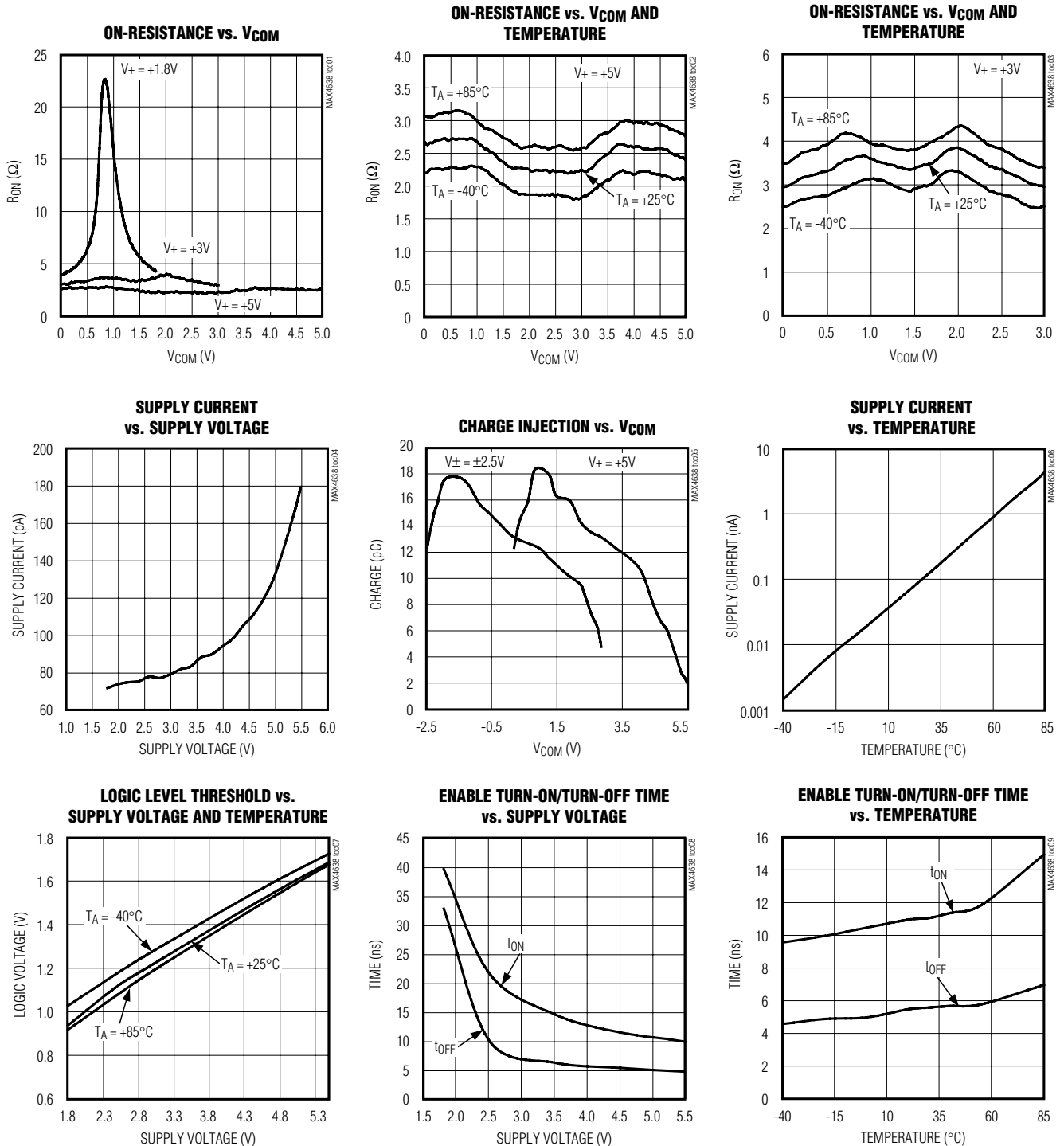

MAX4638/MAX4639

3.5Ω, Single 8:1 and Dual 4:1, Low-Voltage Analog Multiplexers

Typical Operating Characteristics (continued)

(V+ = +5V, V- = 0V, T_A = +25°C, unless otherwise noted.)

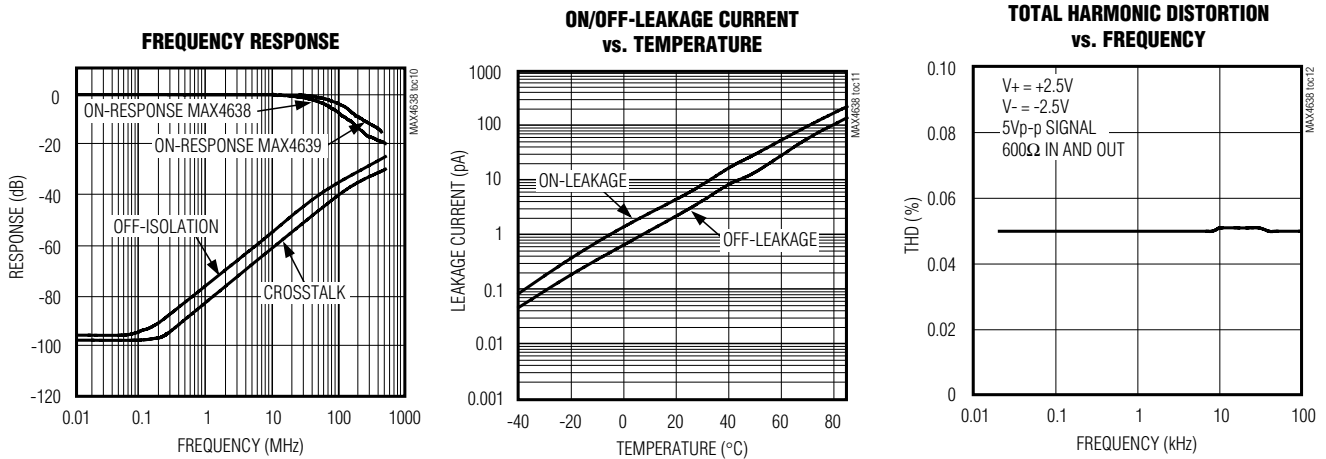

Pin Description

PIN						NAME	FUNCTION
MAX4638			MAX4639				
DIP/SO	TQFN-EP		DIP/SO	TQFN-EP			
	16-PIN	20-PIN		16-PIN	20-PIN		
1, 15, 16	15, 13, 14	19, 18, 17	—	—	—	A0, A2, A1	Address Inputs
—	—	—	1, 16	15, 14	19, 17	A0, A1	Address Inputs
2	16	1	2	16	1	EN	Enable
3	1	2	3	1	2	V-	Negative-Supply Voltage Input
4-7	2-5	3-6	—	—	—	NO1-NO4	Bidirectional Analog Inputs
—	—	—	4-7	2-5	3-6	NO1A-NO4A	Bidirectional Analog Inputs
8	6	7	—	—	—	COM	Bidirectional Analog outputs
—	—	—	8, 9	6, 7	7, 9	COMA, COMB	Bidirectional Analog outputs
9-12	7-10	10-13	—	—	—	NO8-NO5	Bidirectional Analog Inputs
—	—	—	10-13	8-11	10-13	NO4B-NO1B	Bidirectional Analog Inputs
13	11	14	14	12	14	V+	Positive-Supply Voltage Input
14	12	15	15	13	15	GND	Ground
—	—	8, 9, 16, 20	—	—	8, 16, 18, 20	N.C.	No Connection. Not internally connected.
—	—	—	—	—	—	EP	Exposed Pad (TQFN Only). Connect EP to V-.

MAX4638/MAX4639

3.5Ω, Single 8:1 and Dual 4:1, Low-Voltage Analog Multiplexers

Detailed Description

The MAX4638/MAX4639 are low-voltage, CMOS analog muxes. The MAX4638 is an 8:1 mux that switches one of eight inputs (NO1–NO8) to a common output (COM) as determined by the 3-bit binary inputs A0, A1, and A2. The MAX4639 is a 4:1 dual mux that switches one of four differential inputs to a common differential output as determined by the 2-bit binary inputs A0 and A1. Both the MAX4638/MAX4639 have an EN input that can be used to enable or disable the device. When disabled, all channels are switched off. See Truth Tables.

Applications Information

Overvoltage Protection

Proper power-supply sequencing is recommended for all CMOS devices. Do not exceed the absolute maximum ratings because stresses beyond the listed ratings can cause permanent damage to the devices. Always sequence V+ on first, then V-, followed by the logic inputs. If power-supply sequencing is not possible, add two small-signal diodes (D1, D2) in series with the supply pins for overvoltage protection (Figure 1). Adding diodes reduces the analog signal range to one diode drop below V+ and one diode drop above V-, but

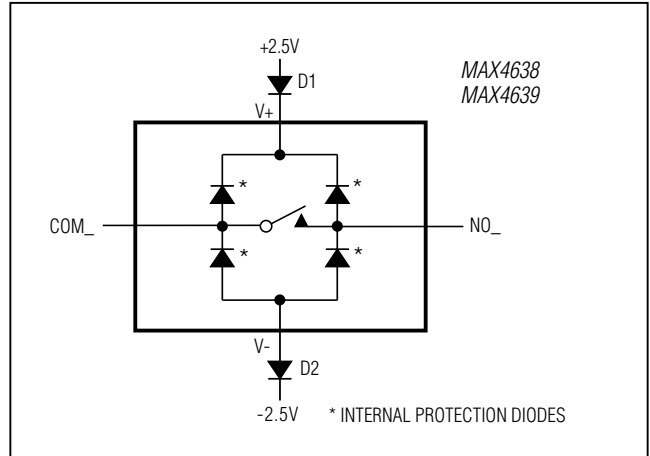

Figure 1. Overvoltage Protection Using External Blocking Diodes

does not affect the devices' low switch resistance. Device operation is unchanged, and the difference between V+ and V- should not exceed 6V. These protection diodes are not recommended when using a single supply. For single-supply operation, V- should be connected to GND as close to the device as possible.

Truth Tables

MAX4638 (Single 8-to-1 Mux)

A2	A1	A0	EN	ON SWITCH
X	X	X	0	None
0	0	0	1	NO1
0	0	1	1	NO2
0	1	0	1	NO3
0	1	1	1	NO4
1	0	0	1	NO5
1	0	1	1	NO6
1	1	0	1	NO7
1	1	1	1	NO8

MAX4639 (Dual 4-to-1 Mux)

A1	A0	EN	COMA	COMB
X	X	0	None	None
0	0	1	NO1A	NO1B
0	1	1	NO2A	NO2B
1	0	1	NO3A	NO3B
1	1	1	NO4A	NO4B

MAX4638/MAX4639

3.5Ω, Single 8:1 and Dual 4:1, Low-Voltage Analog Multiplexers

Test Circuits/Timing Diagrams

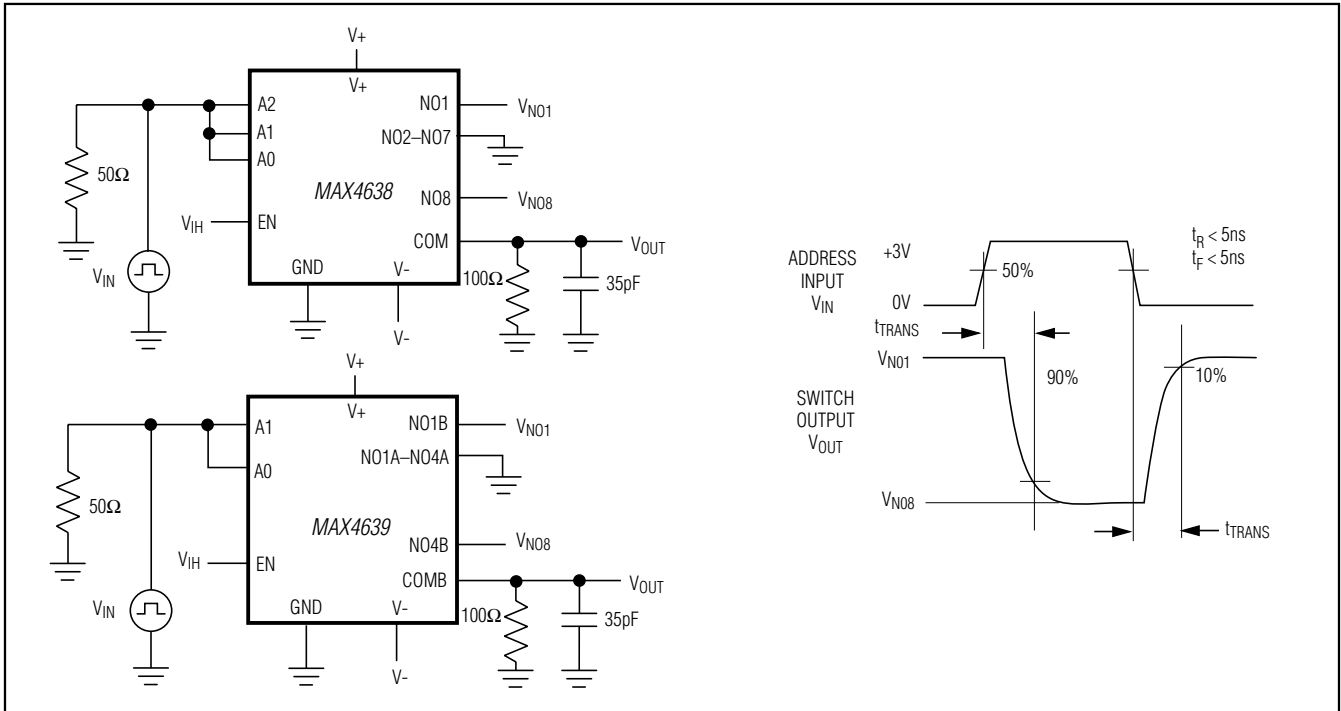

Figure 2. Transition Time

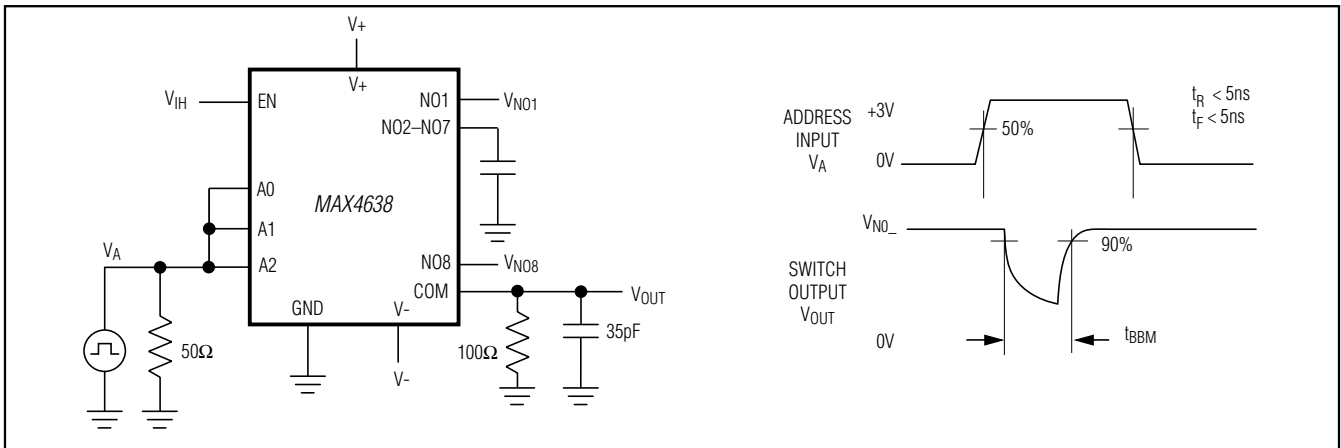

Figure 3. MAX4638 Break-Before-Make Interval

MAX4638/MAX4639

3.5Ω, Single 8:1 and Dual 4:1, Low-Voltage Analog Multiplexers

Test Circuits/Timing Diagrams (continued)

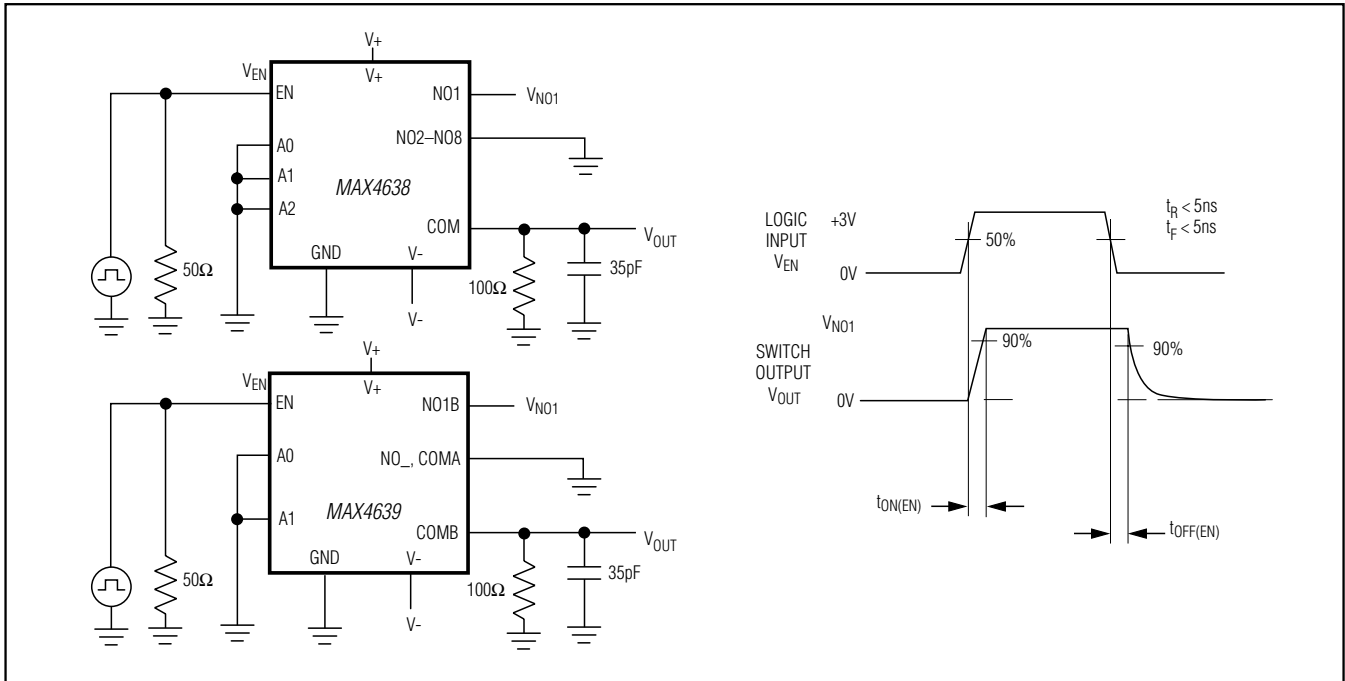

Figure 4. Enable Switching Time

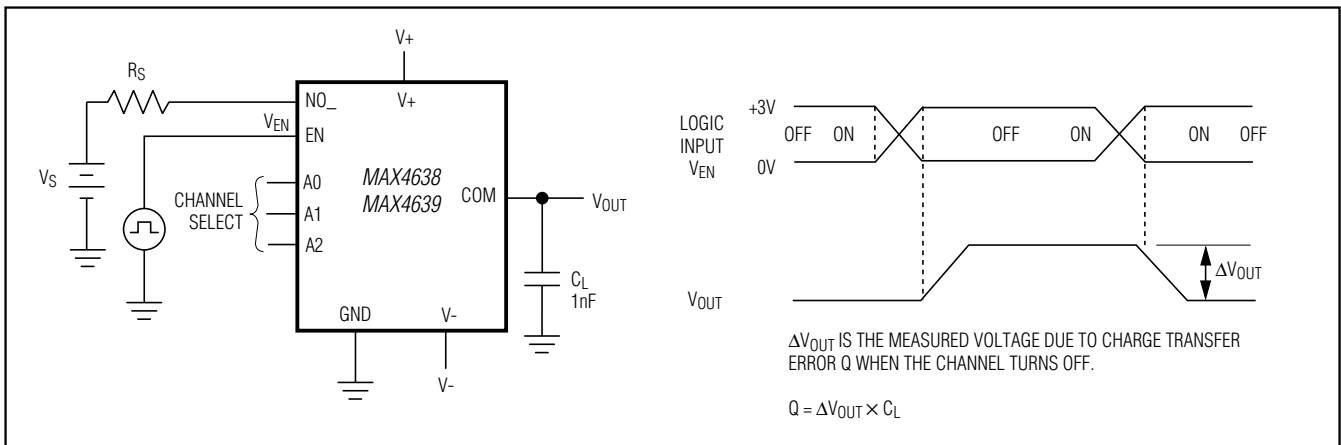

Figure 5. Charge Injection

MAX4638/MAX4639

3.5Ω, Single 8:1 and Dual 4:1, Low-Voltage Analog Multiplexers

Test Circuits/Timing Diagrams (continued)

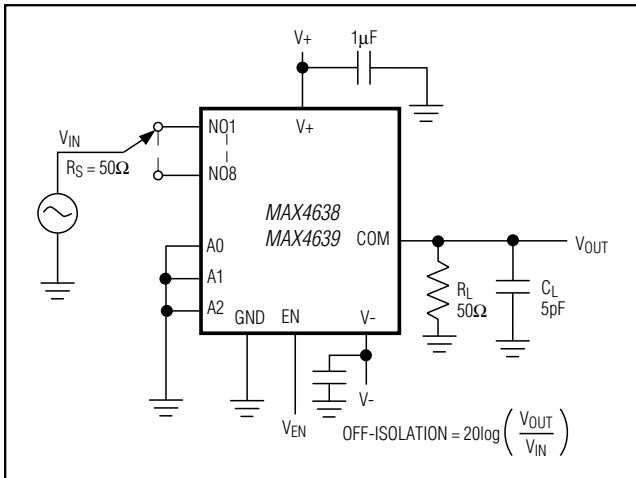

Figure 6. Off-Isolation/On-Channel Bandwidth

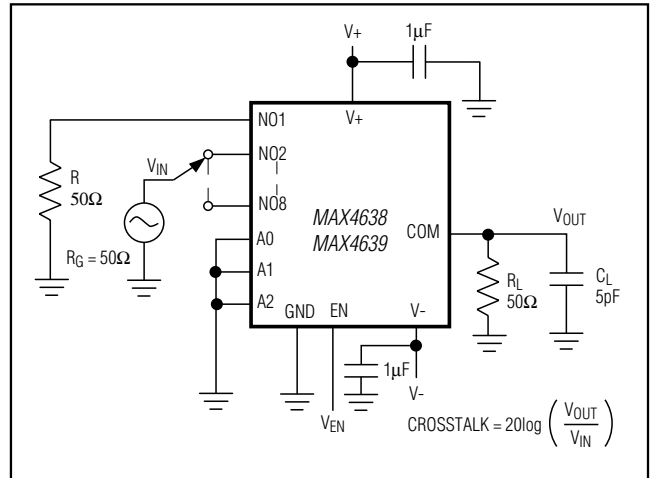

Figure 7. Crosstalk

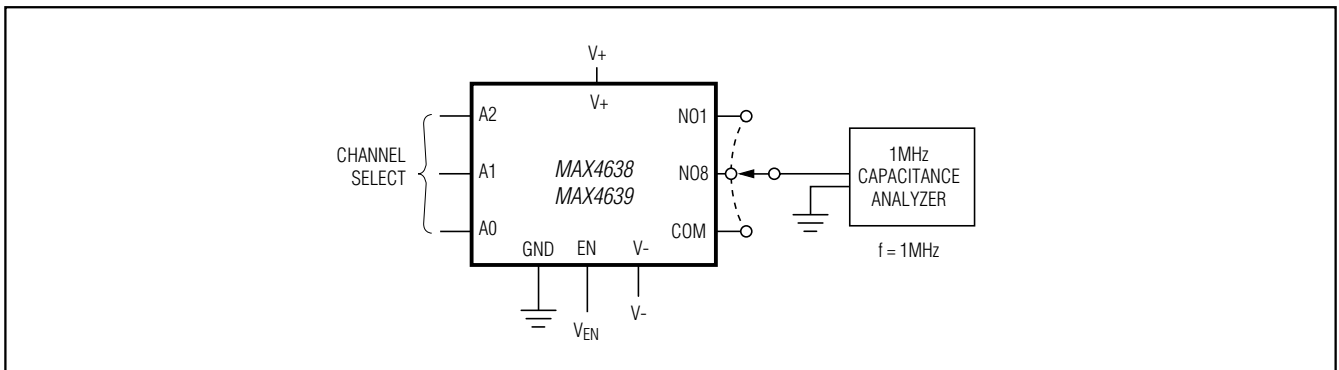
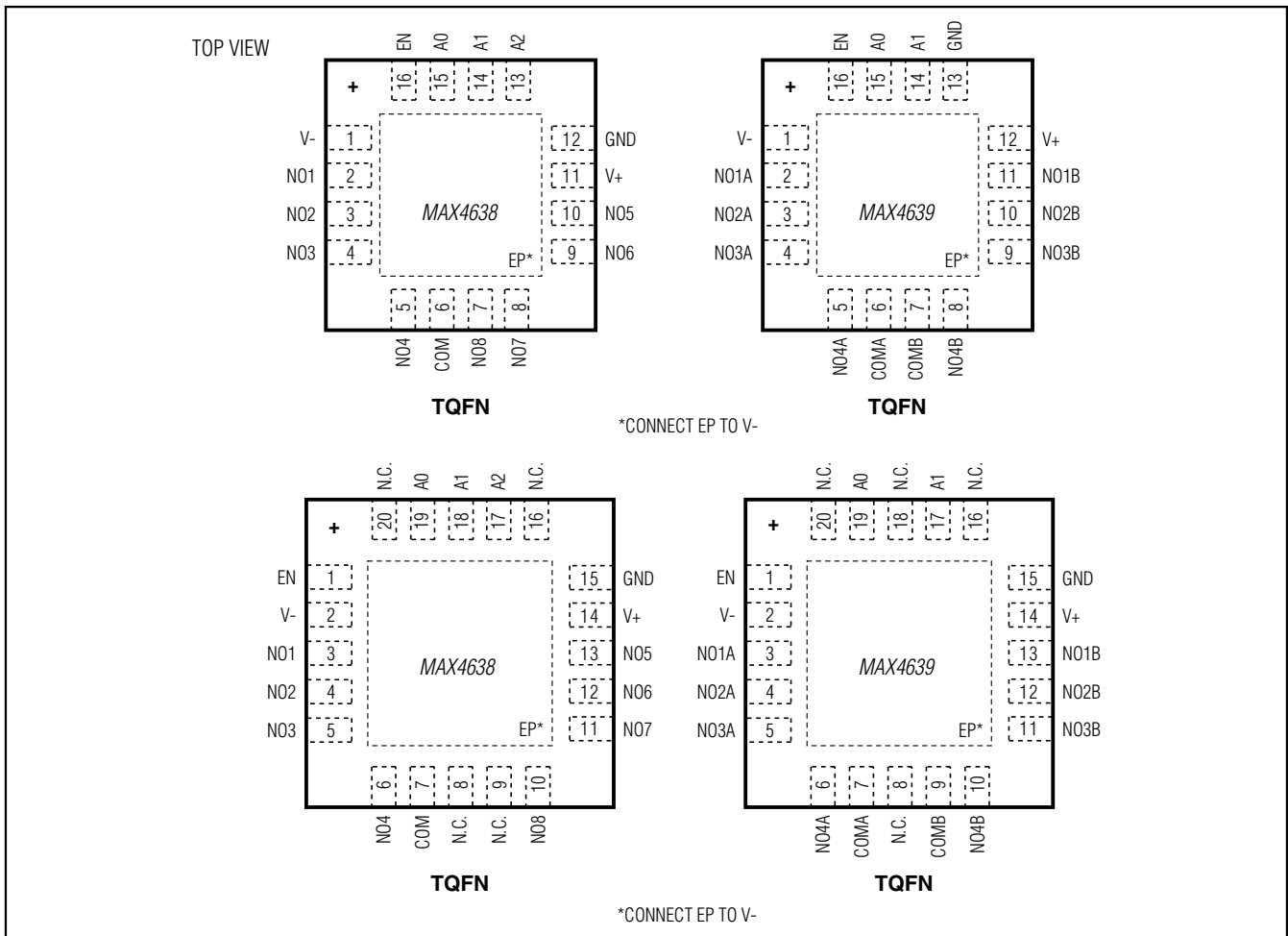

Figure 8. Channel Off/On-Capacitance

MAX4638/MAX4639

3.5Ω, Single 8:1 and Dual 4:1, Low-Voltage Analog Multiplexers

Pin Configurations (continued)



Ordering Information (continued)

PART	TEMP RANGE	PIN-PACKAGE
MAX4639ETE+T	-40°C to +85°C	16 TQFN-EP* (4 × 4)
MAX4639EUE+T	-40°C to +85°C	16 TSSOP
MAX4639ESE+T	-40°C to +85°C	16 SO
MAX4639ETP+T	-40°C to +85°C	20 TQFN-EP* (4 × 4)

+Denotes a lead(Pb)-free/RoHS-compliant package.

T = Tape and reel.

*EP = Exposed pad.

Chip Information

PROCESS: BiCMOS

Package Information

For the latest package outline information and land patterns (footprints), go to www.maximintegrated.com/packages. Note that a "+", "#", or "-" in the package code indicates RoHS status only. Package drawings may show a different suffix character, but the drawing pertains to the package regardless of RoHS status.

PACKAGE TYPE	PACKAGE CODE	OUTLINE NO.	LAND PATTERN NO.
16 TQFN	T1644+4	21-0139	90-0070
20 TQFN	T1644+3	21-0139	90-0069
16 TSSOP	U16+2	21-0066	90-0117
16 SO	S16+3	21-0041	90-0097

MAX4638/MAX4639

3.5Ω, Single 8:1 and Dual 4:1,Z Low-Voltage Analog Multiplexers

Revision History

REVISION NUMBER	REVISION DATE	DESCRIPTION	PAGES CHANGED
2	9/10	—	—
3	10/12	Added RoHS ordering information throughout data sheet	1–16



Maxim Integrated cannot assume responsibility for use of any circuitry other than circuitry entirely embodied in a Maxim Integrated product. No circuit patent licenses are implied. Maxim Integrated reserves the right to change the circuitry and specifications without notice at any time. The parametric values (min and max limits) shown in the Electrical Characteristics table are guaranteed. Other parametric values quoted in this data sheet are provided for guidance.

Looking for pricing, stock, or lifecycle information?

Click below to explore more details on WIN SOURCE:

 [View MAX4638ETE+ on WIN SOURCE](#)

 [Maxim Integrated](#) Information

Optimize Your Supply Chain with WIN SOURCE Solutions

-  Global Sourcing Solution
-  Obsolete Management
-  Cost Control Management
-  Shortage Management
-  Alternative Solution
-  Excess Inventory Management