



Low-Cost, 144MHz, Dual/Triple Op Amps with $\pm 15\text{kV}$ ESD Protection

MAX4030E/MAX4031E

General Description

The MAX4030E/MAX4031E unity-gain stable op amps combine high-speed performance, rail-to-rail outputs, and $\pm 15\text{kV}$ ESD protection. Targeted for applications where an input or an output is exposed to the outside world, such as video and communications, these devices are compliant with International ESD Standards: $\pm 15\text{kV}$ IEC 1000-4-2 Air-Gap Discharge, $\pm 8\text{kV}$ IEC 1000-4-2 Contact Discharge, and the $\pm 15\text{kV}$ Human Body Model.

The MAX4030E/MAX4031E operate from a single 5V supply and consume only 12mA of quiescent supply current per amplifier while achieving a 144MHz -3dB bandwidth, 20MHz 0.1dB gain flatness, and a 115V/ μs slew rate. The MAX4031E provides individual shutdown control for each of the amplifiers.

The dual MAX4030E is available in 8-pin $\mu\text{MAX}^{\circledR}$ and SO packages, and the triple MAX4031E is available in 14-pin TSSOP and SO packages. All devices are specified over the -40°C to $+85^{\circ}\text{C}$ extended temperature range.

Applications

Set-Top Boxes	Notebooks
Standard Definition Television (SDTV)	Projectors
Enhanced Television (ETV)	Security Video Systems
High-Definition Television (HDTV)	Camcorders
	Digital Still Cameras
	Portable DVD Players

μMAX is a registered trademark of Maxim Integrated Products, Inc.

Pin Configurations

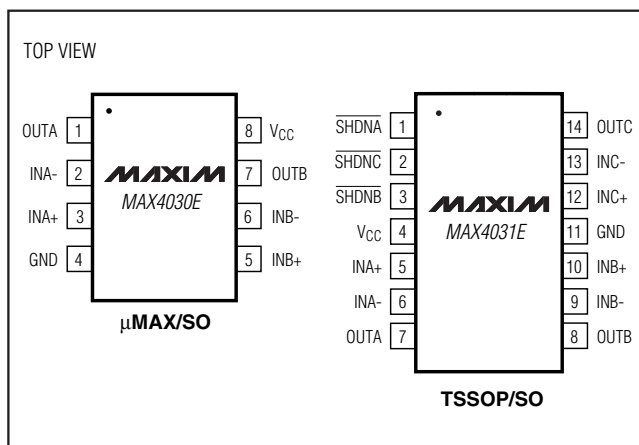

Features

- ◆ ESD-Protected Video Inputs and Outputs
 - ±15kV – Human Body Model
 - ±8kV – IEC 1000-4-2 Contact Discharge
 - ±15kV – IEC 1000-4-2 Air-Gap Discharge
- ◆ 5V Single-Supply Operation
- ◆ 0.1 μA Low-Power Shutdown Mode (MAX4031E)
- ◆ Input Common-Mode Range Extends to Ground
- ◆ 2V_{p-p} Large-Signal -3dB BW > 50MHz
- ◆ Directly Drives 150 Ω Loads
- ◆ Low Differential Gain/Phase: 0.2%/0.2°
- ◆ -40°C to $+85^{\circ}\text{C}$ Extended Temperature Range
- ◆ Compact 8-Pin μMAX and 14-Pin TSSOP Packages

Ordering Information

PART	TEMP RANGE	PIN-PACKAGE
MAX4030EEUA	-40°C to $+85^{\circ}\text{C}$	8 μMAX
MAX4030EESA	-40°C to $+85^{\circ}\text{C}$	8 SO
MAX4031EEUD	-40°C to $+85^{\circ}\text{C}$	14 TSSOP
MAX4031EESD	-40°C to $+85^{\circ}\text{C}$	14 SO

Typical Operating Circuit

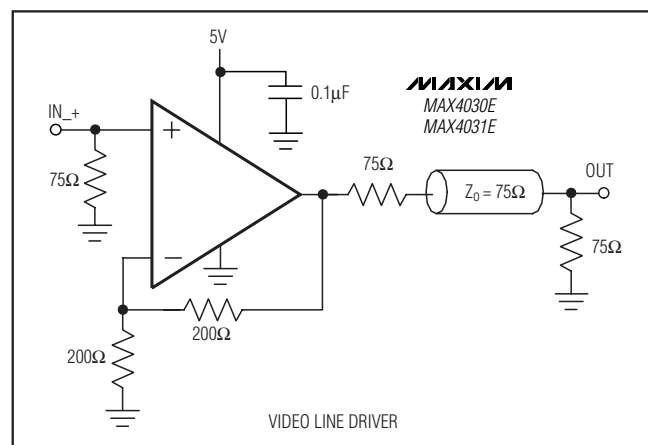

Low-Cost, 144MHz, Dual/Triple Op Amps with $\pm 15kV$ ESD Protection

ABSOLUTE MAXIMUM RATINGS

(All voltages referenced to GND, unless otherwise noted.)

V _{CC}	-0.3V to +6V
IN ₋ , IN ₊ , OUT ₋ , SHDN ₋	-0.3V to (V _{CC} + 0.3V)
Current into IN ₋ , IN ₊ , SHDN ₋	$\pm 20mA$
Output Short-Circuit Duration to V _{CC} or GND	Continuous
Continuous Power Dissipation (T _A = +70°C)	
8-Pin μ MAX (derate 4.5mW/°C above +70°C)	362mW
8-Pin SO (derate 5.9mW/°C above +70°C)	471mW

14-Pin TSSOP (derate 9.1mW/°C above +70°C)	727mW
14-Pin SO (derate 8.3mW/°C above +70°C)	667mW
Operating Temperature Range	-40°C to +85°C
Junction Temperature	+150°C
Storage Temperature Range	-65°C to +150°C
Lead Temperature (soldering, 10s)	+300°C

Stresses beyond those listed under "Absolute Maximum Ratings" may cause permanent damage to the device. These are stress ratings only, and functional operation of the device at these or any other conditions beyond those indicated in the operational sections of the specifications is not implied. Exposure to absolute maximum rating conditions for extended periods may affect device reliability.

DC ELECTRICAL CHARACTERISTICS

(V_{CC} = 5V, V_{CM} = 0V, V_{OUT-} = V_{CC}/2, SHDN₋ = V_{CC}, R_L = ∞ to V_{CC}/2, T_A = T_{MIN} to T_{MAX}, unless otherwise noted. Typical values are at T_A = +25°C.) (Note 1)

PARAMETER	SYMBOL	CONDITIONS	MIN	TYP	MAX	UNITS	
Operating Supply Voltage Range	V _{CC}	Guaranteed by PSRR	4.5		5.5	V	
Quiescent Current (per Amplifier)	I _{CC}			12	22	mA	
Shutdown Current (per Amplifier)	I _{SHDN}	SHDN ₋ = GND (MAX4031E)		0.1	10	μ A	
Input Common-Mode Voltage	V _{CM}	Guaranteed by CMRR	0		V _{CC} - 2.25	V	
Input Offset Voltage	V _{OS}	T _A = +25°C		5	13	mV	
		T _A = -40°C to +85°C			26		
Input Offset Voltage Matching	Δ V _{OS}			2.6		mV	
Input Offset Voltage Tempco	TC _{VOS}			31		μ V/°C	
Input Bias Current	I _B			0.01	1	μ A	
Input Offset Current	I _{OS}			0.01		μ A	
Input Resistance	R _{IN}			1		G Ω	
Common-Mode Rejection Ratio	CMRR	GND \leq V _{CM} \leq V _{CC} - 2.25V	50	70		dB	
Power-Supply Rejection Ratio	PSRR	4.5V \leq V _{CC} \leq 5.5V	40	60		dB	
Open-Loop Gain	A _{VOL}	0.5V \leq V _{OUT-} \leq 4.5V, R _L = 2k Ω to V _{CC} /2		80		dB	
		0.6V \leq V _{OUT-} \leq 4.4V, R _L = 150 Ω to V _{CC} /2	50	70			
		0.4V \leq V _{OUT-} \leq 3.5V, R _L = 150 Ω to GND	50	70			
Output Voltage Swing	V _{OUT-}	R _L = 2k Ω to V _{CC} /2	V _{CC} - V _{OH}		0.05	V	
			V _{OL} - GND		0.05		
		R _L = 150 Ω to V _{CC} /2	V _{CC} - V _{OH}		0.15		0.4
			V _{OL} - GND		0.15		0.4
		R _L = 150 Ω to GND	V _{CC} - V _{OH}		0.3		0.8
			V _{OL} - GND		0.01		0.05
Output Short-Circuit Current	I _{SC}	Sinking or sourcing		± 100		mA	
SHDN ₋ Logic Threshold	V _{IL}	MAX4031E			0.8	V	
	V _{IH}	MAX4031E	2.0				
SHDN ₋ Logic Input Current	I _{IL}	SHDN ₋ = GND (MAX4031E)		0.10	10	μ A	
	I _{IH}	SHDN ₋ = V _{CC} (MAX4031E)		0.10	10		

Low-Cost, 144MHz, Dual/Triple Op Amps with $\pm 15\text{kV}$ ESD Protection

MAX4030E/MAX4031E

DC ELECTRICAL CHARACTERISTICS (continued)

($V_{CC} = 5\text{V}$, $V_{CM} = 0\text{V}$, $V_{OUT_} = V_{CC}/2$, $\overline{\text{SHDN_}} = V_{CC}$, $R_L = \infty$ to $V_{CC}/2$, $T_A = T_{MIN}$ to T_{MAX} , unless otherwise noted. Typical values are at $T_A = +25^\circ\text{C}$.) (Note 1)

PARAMETER	SYMBOL	CONDITIONS	MIN	TYP	MAX	UNITS
Disabled Output Leakage Current	I_{OUT_SH}	$\overline{\text{SHDN_}} = \text{GND}$ (MAX4031E)		0.1	10	μA
ESD Protection Voltage (Note 2)		Human Body Model		± 15		kV
		IEC 1000-4-2 Contact Discharge		± 8		
		IEC 1000-4-2 Air-Gap Discharge		± 15		

AC ELECTRICAL CHARACTERISTICS

($V_{CC} = 5\text{V}$, $V_{CM} = 1.5\text{V}$, $R_L = 150\Omega$ to GND, $\overline{\text{SHDN_}} = V_{CC}$, $A_{VCL_} = +2\text{V/V}$, $T_A = +25^\circ\text{C}$, unless otherwise noted.)

PARAMETER	SYMBOL	CONDITIONS	MIN	TYP	MAX	UNITS
Small-Signal -3dB Bandwidth	BW_{SS}	$V_{OUT_} = 100\text{mV}_{P-P}$, $A_{VCL_} = +1\text{V/V}$		144		MHz
		$V_{OUT_} = 100\text{mV}_{P-P}$, $A_{VCL_} = +2\text{V/V}$		53		
Large-Signal -3dB Bandwidth	BW_{LS}	$V_{OUT_} = 2\text{V}_{P-P}$, $A_{VCL_} = +1\text{V/V}$		52		MHz
		$V_{OUT_} = 2\text{V}_{P-P}$, $A_{VCL_} = +2\text{V/V}$		40		
Small-Signal 0.1dB Gain Flatness	$BW_{0.1dBSS}$	$V_{OUT_} = 100\text{mV}_{P-P}$, $A_{VCL_} = +1\text{V/V}$		20		MHz
		$V_{OUT_} = 100\text{mV}_{P-P}$, $A_{VCL_} = +2\text{V/V}$		10		
Large-Signal 0.1dB Gain Flatness	$BW_{0.1dBLS}$	$V_{OUT_} = 2\text{V}_{P-P}$, $A_{VCL_} = +1\text{V/V}$		20		MHz
		$V_{OUT_} = 2\text{V}_{P-P}$, $A_{VCL_} = +2\text{V/V}$		9		
Slew Rate	SR	$V_{OUT_} = 2\text{V}$ step		115		$\text{V}/\mu\text{s}$
Settling Time to 0.1%	t_S	$V_{OUT_} = 2\text{V}$ step		40		ns
Channel-to-Channel Isolation	CH_{ISO}	$f = 4.43\text{MHz}$		65		dB
Differential Phase Error	DP	NTSC, $R_L = 150\Omega$ to GND, $A_{VCL_} = +2\text{V/V}$		0.2		Degrees
Differential Gain Error	DG	NTSC, $R_L = 150\Omega$ to GND, $A_{VCL_} = +2\text{V/V}$		0.2		%
Input Capacitance	C_{IN}			8		pF
Capacitive-Load Stability		No sustained oscillations		200		pF
Output Impedance	Z_{OUT}	$f = 4.43\text{MHz}$		2		Ω
Enable Time	t_{ON}	$V_{IN_} = 1\text{V}$ (MAX4031E)		2		μs
Disable Time	t_{OFF}	$V_{IN_} = 1\text{V}$ (MAX4031E)		0.15		μs

Note 1: All devices are 100% production tested at $T_A = +25^\circ\text{C}$. Specifications over temperature limits are guaranteed by design.

Note 2: ESD protection is specified for test point A and test point B only (Figure 7).

Low-Cost, 144MHz, Dual/Triple Op Amps with $\pm 15kV$ ESD Protection

Typical Operating Characteristics

($V_{CC} = 5V$, $V_{CM} = 1.5V$, $A_{VCL} = +2V/V$, $R_L = 150\Omega$ to $V_{CC}/2$, $T_A = +25^\circ C$, unless otherwise noted.)

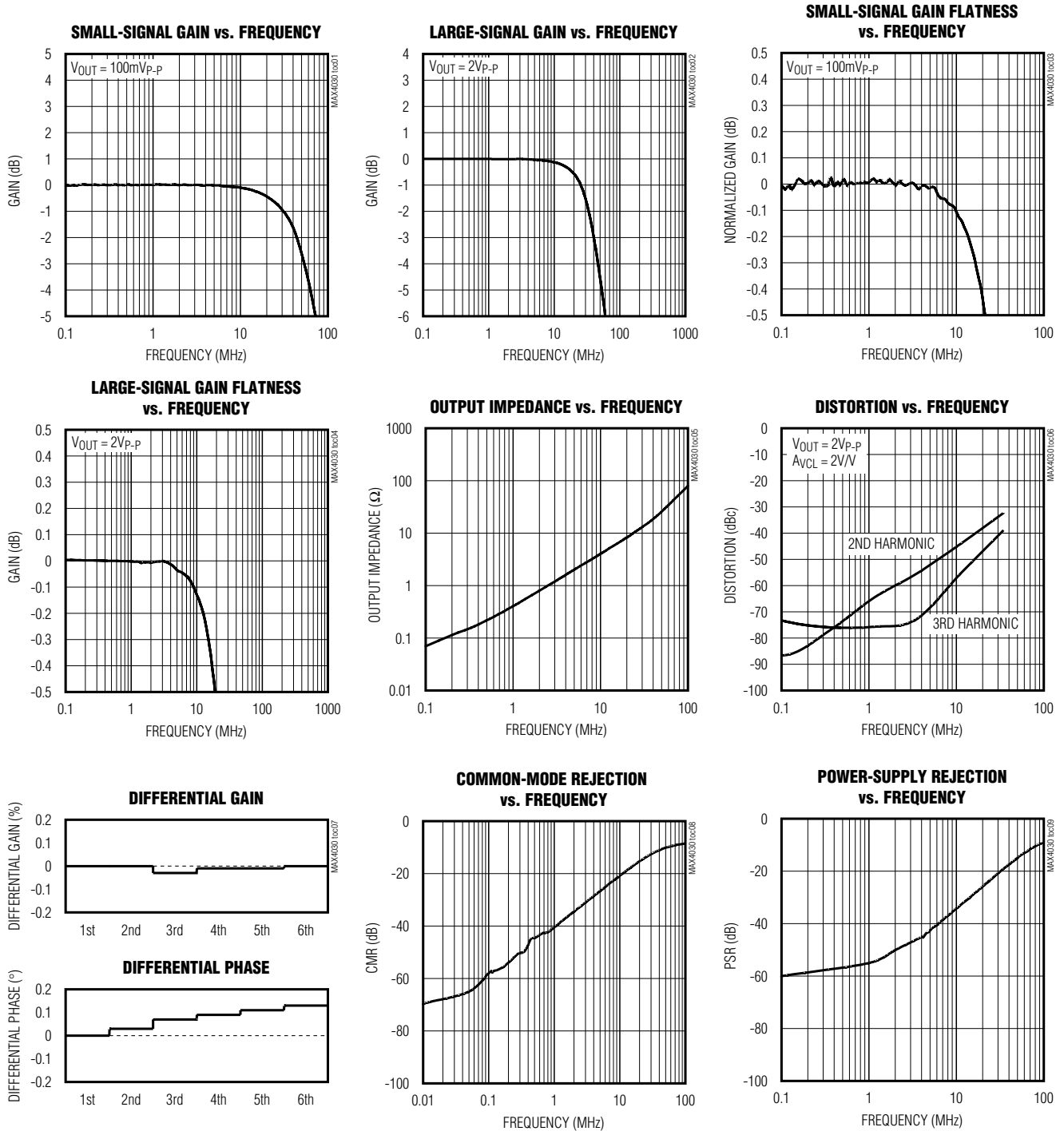

Low-Cost, 144MHz, Dual/Triple Op Amps with $\pm 15kV$ ESD Protection

Typical Operating Characteristics (continued)

($V_{CC} = 5V$, $V_{CM} = 1.5V$, $A_{VCL} = +2V/V$, $R_L = 150\Omega$ to $V_{CC}/2$, $T_A = +25^\circ C$, unless otherwise noted.)

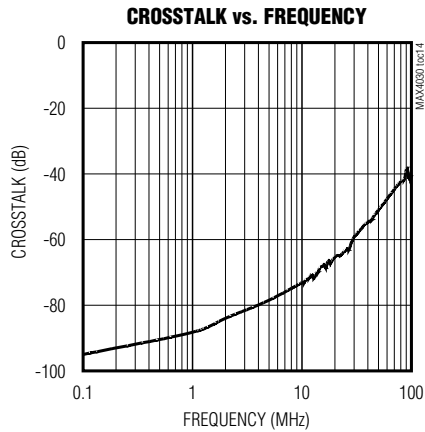
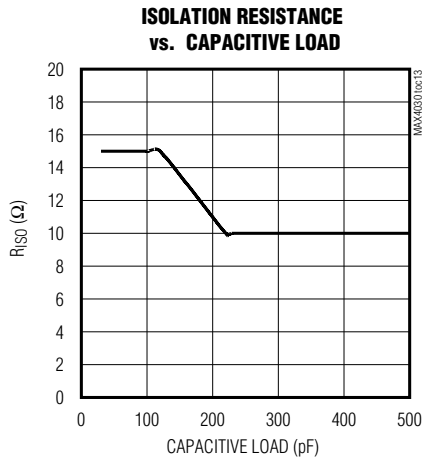
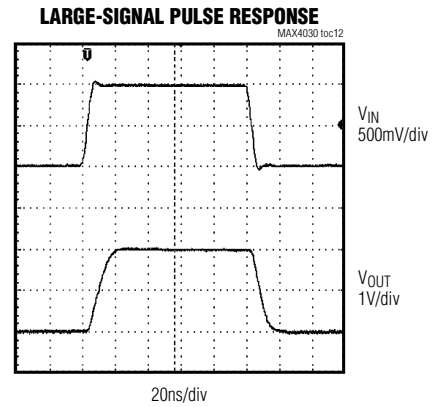
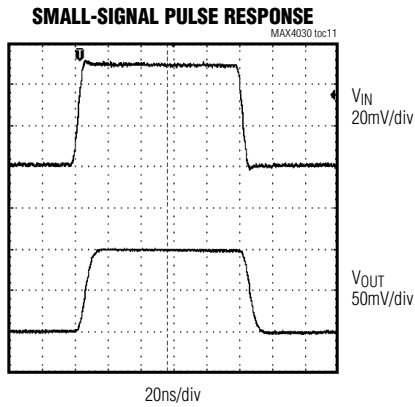
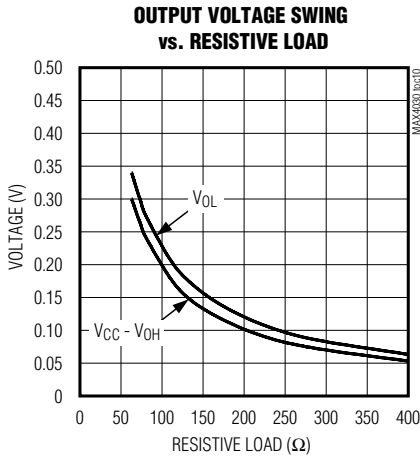

MAX4030E/MAX4031E

Low-Cost, 144MHz, Dual/Triple Op Amps with $\pm 15kV$ ESD Protection

Pin Description

PIN		NAME	FUNCTION
MAX4030E	MAX4031E		
1	7	OUTA	Amplifier A Output
2	6	INA-	Amplifier A Inverting Input
3	5	INA+	Amplifier A Noninverting Input
4	11	GND	Ground
5	10	INB+	Amplifier B Noninverting Input
6	9	INB-	Amplifier B Inverting Input
7	8	OUTB	Amplifier B Output
8	4	V _{CC}	Positive Power Supply. Bypass V _{CC} to GND with a 0.1 μ F capacitor.
—	1	$\overline{\text{SHDNA}}$	Amplifier A Shutdown Input. Connect $\overline{\text{SHDNA}}$ high to enable amplifier A.
—	2	$\overline{\text{SHDNC}}$	Amplifier C Shutdown Input. Connect $\overline{\text{SHDNC}}$ high to enable amplifier C.
—	3	$\overline{\text{SHDNB}}$	Amplifier B Shutdown Input. Connect $\overline{\text{SHDNB}}$ high to enable amplifier B.
—	12	INC+	Amplifier C Noninverting Input
—	13	INC-	Amplifier C Inverting Input
—	14	OUTC	Amplifier C Output

Detailed Description

The MAX4030E/MAX4031E dual/triple, 5V operational amplifiers achieve 115V/ μ s slew rates and 144MHz bandwidths. High $\pm 15kV$ ESD protection at video inputs and outputs guards against unexpected discharge. Excellent harmonic distortion and differential gain/phase performance make these amplifiers an ideal choice for a wide variety of video and RF signal-processing applications.

Ground-Sensing Inputs

The MAX4030E/MAX4031E input stage can sense common-mode voltages from ground to within 2.25V of the positive supply.

Rail-to-Rail Outputs

The MAX4030E/MAX4031E rail-to-rail outputs can swing to within 100mV of each supply because local feedback around the output stage ensures low open-loop output impedance, reducing gain sensitivity to load variations.

Shutdown (MAX4031E Only)

The MAX4031E offers individual shutdown control for each amplifier. Drive SHDN_ low to shut down the amplifier. In shutdown, the amplifier output impedance is high impedance.

Applications Information

Choosing Resistor Values

Unity-Gain Configuration

The MAX4030E/MAX4031E are internally compensated for unity gain. When configured for unity gain, a 24 Ω resistor (R_F) in series with the feedback path optimizes AC performance. This resistor improves AC response by reducing the Q of the parallel LC circuit formed by the parasitic feedback capacitance and lead inductance.

Video Line Driver

The MAX4030E/MAX4031E are low-power, voltage-feedback amplifiers featuring bandwidths up to 40MHz and 0.1dB gain flatness to 9MHz. They are designed to minimize differential-gain error and differential-phase error to 0.2% and 0.2°, respectively. They have a 40ns settling time to 0.1%, 110V/ μ s slew rates, and output-current-drive capability of up to 50mA, making them ideal for driving video loads.

Inverting and Noninverting Configurations

Select the feedback (R_F) and input (R_G) resistor values to fit the gain requirements of the application. Large resistor values increase voltage noise and interact with the amplifier's input and PC board capacitance. This can generate undesirable poles and zeros and

Low-Cost, 144MHz, Dual/Triple Op Amps with $\pm 15\text{kV}$ ESD Protection

MAX4030E/MAX4031E

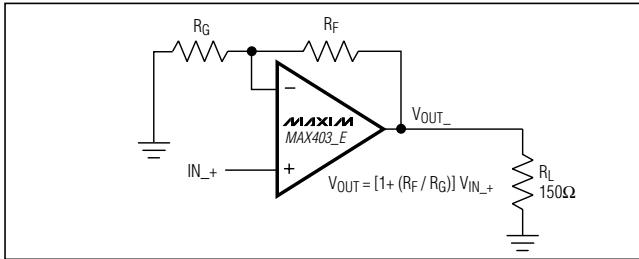

Figure 1. Noninverting Gain Configuration

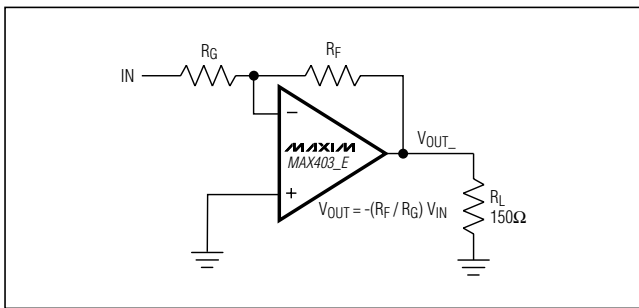

Figure 2. Inverting Gain Configuration

decrease bandwidth or cause oscillations. For example, a noninverting gain-of-two configuration ($R_F = R_G$) using $2\text{k}\Omega$ resistors, combined with 4pF of amplifier input capacitance and 1pF of PC board capacitance, cause a pole at 79.6MHz . Since this pole is within the amplifier bandwidth, it jeopardizes stability. Reducing the $2\text{k}\Omega$ resistors to 100Ω extends the pole frequency to 1.59GHz , but could limit output swing by adding 200Ω in parallel with the amplifier's load resistor (Figures 1 and 2).

Layout and Power-Supply Bypassing

These amplifiers operate from a single 5V power supply. Bypass V_{CC} to ground with a $0.1\mu\text{F}$ capacitor as close to V_{CC} as possible. Maxim recommends using microstrip and stripline techniques to obtain full bandwidth. To ensure that the PC board does not degrade the amplifier's performance, design it for a frequency greater than 1GHz . Pay careful attention to inputs and outputs to avoid large parasitic capacitance. Under all conditions observe the following design guidelines:

- Do not use wire-wrap boards. Wire-wrap boards are too inductive.
- Do not use IC sockets. Sockets increase parasitic capacitance and inductance.
- Use surface mount instead of through-hole components for better high-frequency performance.

- Use a PC board with at least two layers. The PC board should be as free from voids as possible.
- Keep signal lines as short and as straight as possible. Do not make 90° turns; round all corners.

Output Capacitive Loading and Stability

The MAX4030E/MAX4031E are optimized for AC performance and do not drive highly reactive loads, which decreases phase margin and can produce excessive ringing and oscillation. Figure 3 shows a circuit modification that uses an isolation resistor (R_{ISO}) to eliminate this problem. Figure 4 shows a graph of the Optimal Isolation Resistor (R_{ISO}) vs. Capacitive Load. Figure 5 shows how a capacitive load causes excessive peaking of the amplifier's frequency response if the capacitor is not isolated from the amplifier by a resistor. A small isolation resistor (usually 10Ω to 15Ω) placed before the reactive load prevents ringing and oscillation. At higher capacitive loads, the interaction of the load capacitance and the isolation resistor controls the AC performance. Figure 6 shows the effect of a 10Ω isolation resistor on closed-loop response.

ESD Protection

As with all Maxim devices, ESD protection structures are incorporated on all pins to protect against ESD encountered during handling and assembly. Input and output pins of the MAX4030E/MAX4031E have extra protection against static electricity. Maxim's engineers have developed state-of-the-art structures enabling these pins to withstand ESD up to $\pm 15\text{kV}$ without damage when placed in the test circuit (Figure 7). The MAX4030E/MAX4031E are characterized for protection to the following limits:

- $\pm 15\text{kV}$ using the Human Body Model
- $\pm 8\text{kV}$ using the Contact Discharge method specified in IEC 1000-4-2
- $\pm 15\text{kV}$ using the Air-Gap Discharge method specified in IEC 1000-4-2

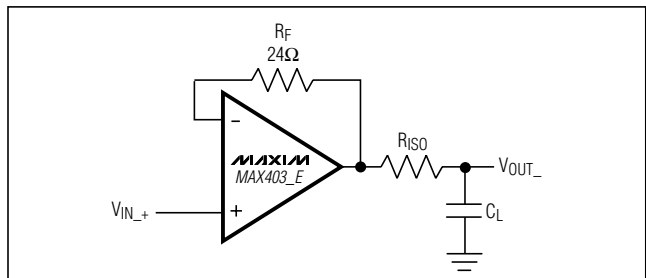

Figure 3. Driving a Capacitive Load Through an Isolation Resistor

Low-Cost, 144MHz, Dual/Triple Op Amps with $\pm 15kV$ ESD Protection

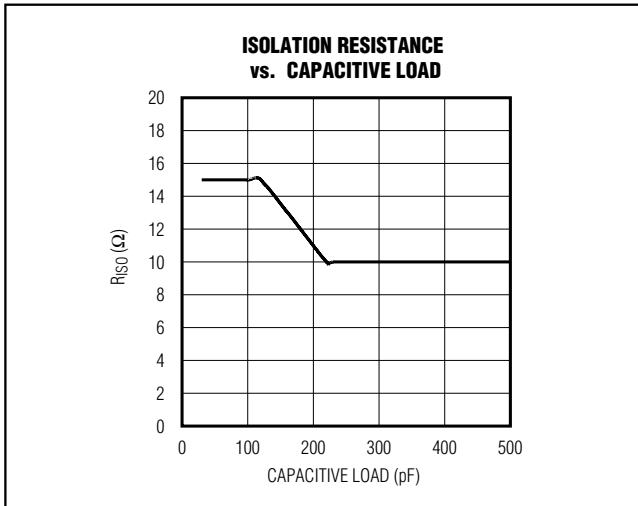

Figure 4. Isolation Resistance vs. Capacitive Load

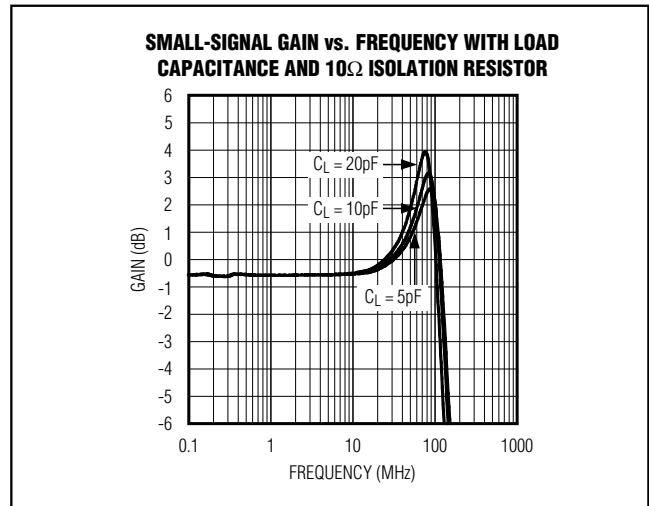

Figure 6. Small-Signal Gain vs. Frequency with Load Capacitance and 10Ω Isolation Resistor

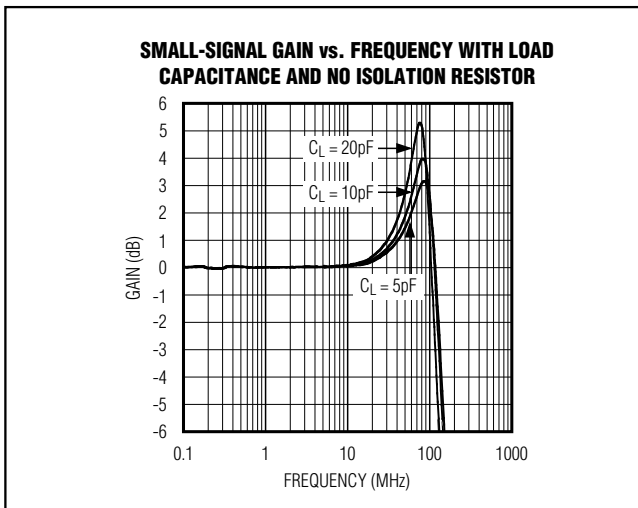

Figure 5. Small-Signal Gain vs. Frequency with Load Capacitance and No Isolation Resistor

Human Body Model

Figure 8 shows the Human Body Model and Figure 9 shows the current waveform it generates when discharged into low impedance. This model consists of a 150pF capacitor charged to the ESD voltage of interest, and then discharged into the test device through a 1.5kΩ resistor.

IEC 1000-4-2

The IEC 1000-4-2 standard covers ESD testing and performance of finished equipment; it does not specifically refer to ICs. The MAX4030E/MAX4031E enable the design of equipment that meets the highest level (level 4) of IEC 1000-4-2 without the need for additional ESD protection components. The major difference between tests done using the Human Body Model and IEC 1000-4-2 is higher peak current in IEC 1000-4-2. Because series resistance is lower in the IEC 1000-4-2 model, the ESD-withstand voltage measured to this standard is generally lower than that measured using the Human Body. Figure 10 shows the IEC 1000-4-2 model and Figure 11 shows the current waveform for the $\pm 8kV$ IEC 1000-4-2 level 4 ESD Contact Discharge test. The Air-Gap test involves approaching the device with a charged probe. The Contact Discharge method connects the probe to the device before the probe is energized.

Chip Information

MAX4030E TRANSISTOR COUNT: 271
 MAX4031E TRANSISTOR COUNT: 387
 PROCESS: BiCMOS

Low-Cost, 144MHz, Dual/Triple Op Amps with $\pm 15kV$ ESD Protection

MAX4030E/MAX4031E

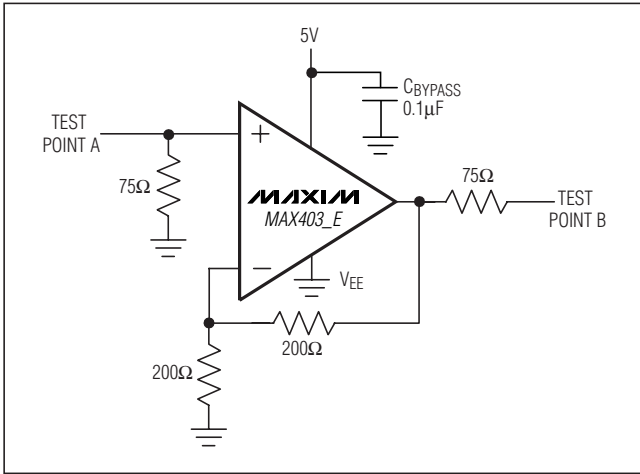

Figure 7. ESD Test Circuit

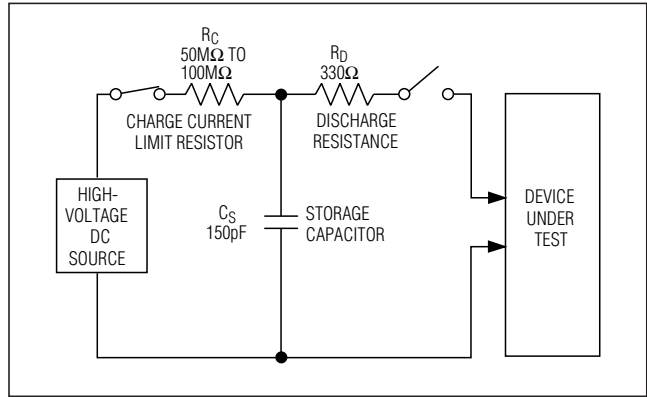

Figure 10. IEC 1000-4-2 ESD Test Model

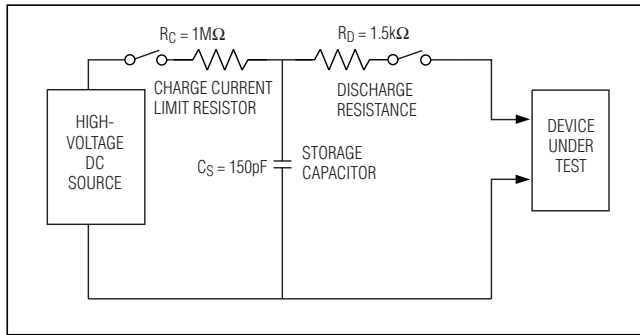

Figure 8. Human Body ESD Model

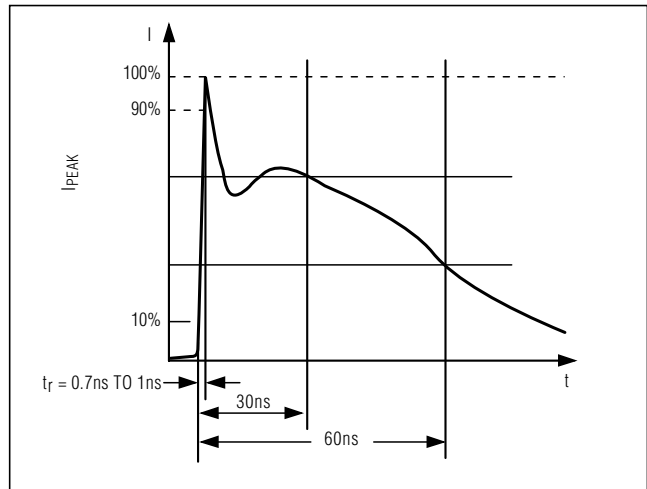

Figure 11. IEC 1000-4-2 ESD Generator Current Waveform

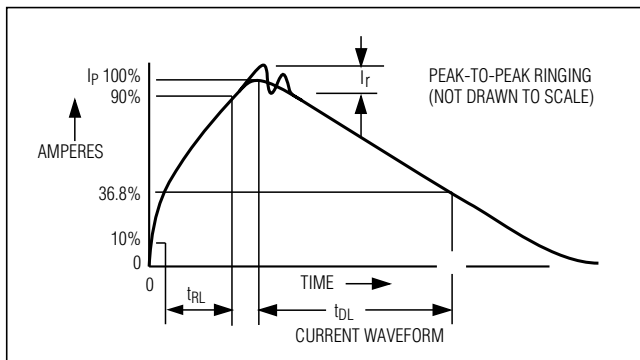
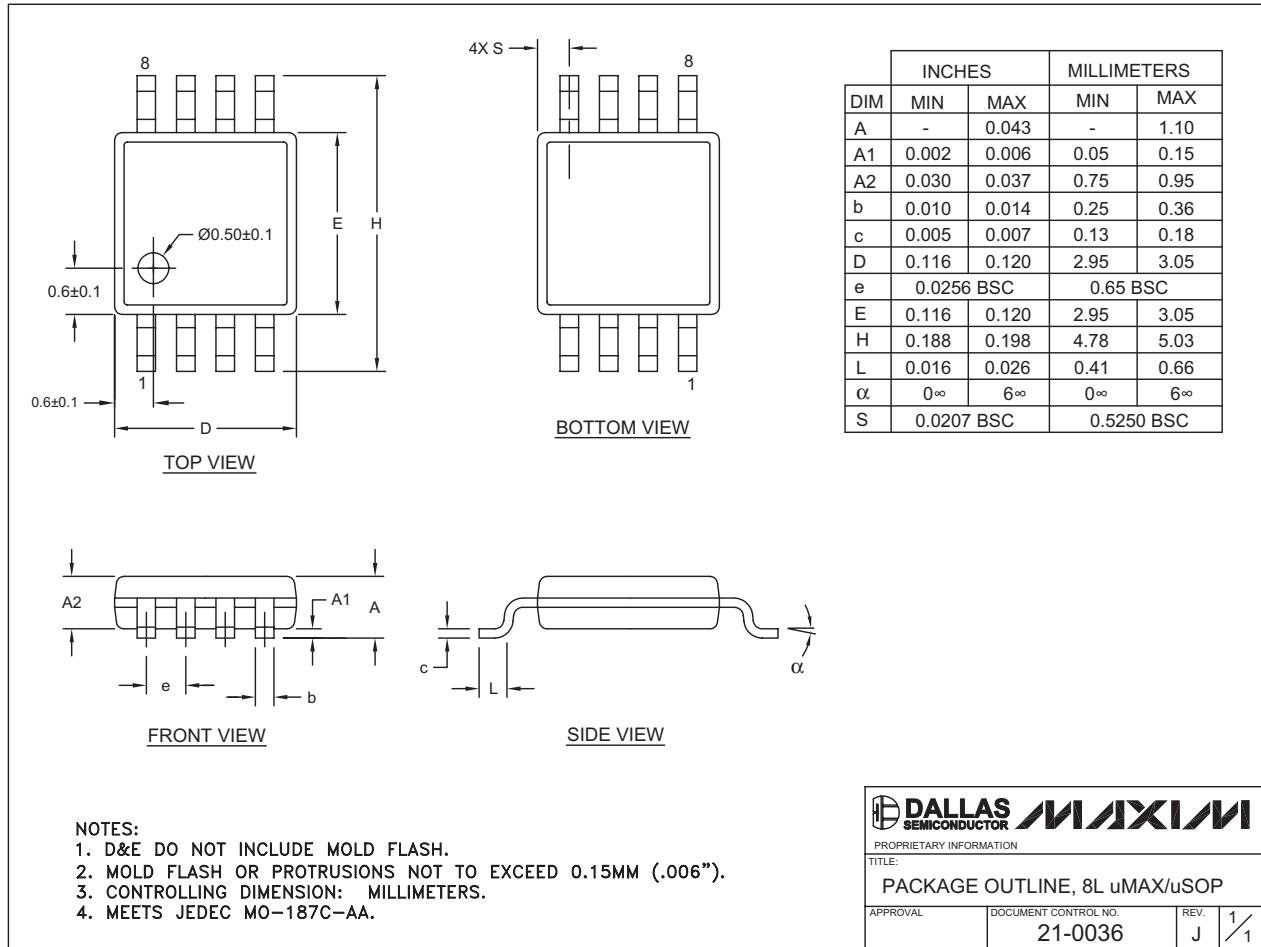

Figure 9. Human Body Current Waveform

Low-Cost, 144MHz, Dual/Triple Op Amps with $\pm 15kV$ ESD Protection

Package Information

(The package drawing(s) in this data sheet may not reflect the most current specifications. For the latest package outline information, go to www.maxim-ic.com/packages.)



8LUMAXD EFS

DALLAS SEMICONDUCTOR **MAXIM**
 PROPRIETARY INFORMATION
 TITLE: PACKAGE OUTLINE, 8L uMAX/uSOP
 APPROVAL: _____ DOCUMENT CONTROL NO. 21-0036 REV. J 1/1

Low-Cost, 144MHz, Dual/Triple Op Amps with $\pm 15kV$ ESD Protection

Package Information (continued)

(The package drawing(s) in this data sheet may not reflect the most current specifications. For the latest package outline information, go to www.maxim-ic.com/packages.)

MAX4030E/MAX4031E

TSSOP4.40mm, EPS

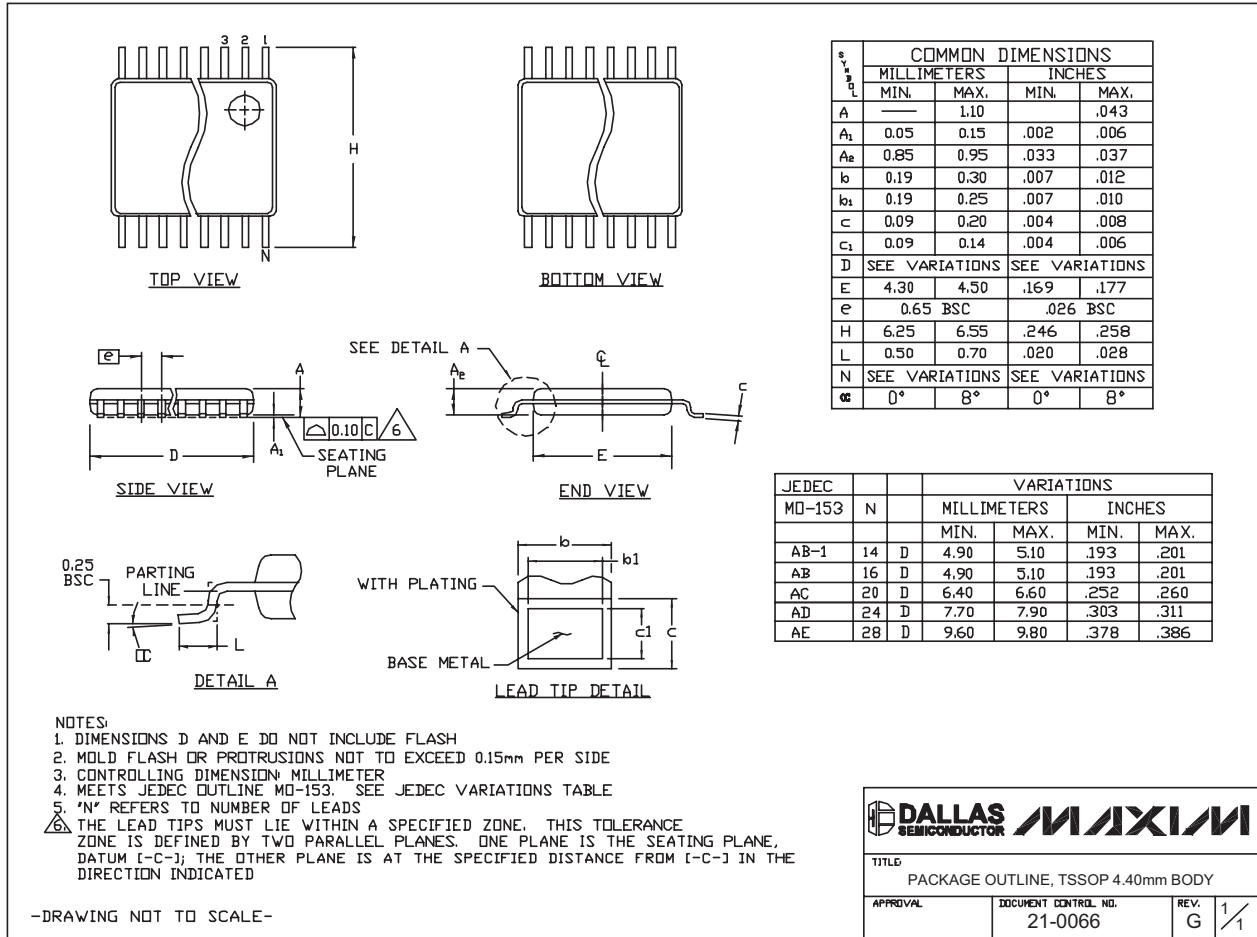

Low-Cost, 144MHz, Dual/Triple Op Amps with $\pm 15kV$ ESD Protection

Package Information (continued)

(The package drawing(s) in this data sheet may not reflect the most current specifications. For the latest package outline information, go to www.maxim-ic.com/packages.)

SOICN EPS

DIM	INCHES		MILLIMETERS	
	MIN	MAX	MIN	MAX
A	0.053	0.069	1.35	1.75
A1	0.004	0.010	0.10	0.25
B	0.014	0.019	0.35	0.49
C	0.007	0.010	0.19	0.25
e	0.050 BSC		1.27 BSC	
E	0.150	0.157	3.80	4.00
H	0.228	0.244	5.80	6.20
L	0.016	0.050	0.40	1.27

VARIATIONS:

DIM	INCHES		MILLIMETERS		N	MS012
	MIN	MAX	MIN	MAX		
D	0.189	0.197	4.80	5.00	8	AA
D	0.337	0.344	8.55	8.75	14	AB
D	0.386	0.394	9.80	10.00	16	AC

NOTES:

1. D&E DO NOT INCLUDE MOLD FLASH.
2. MOLD FLASH OR PROTRUSIONS NOT TO EXCEED 0.15mm (.006").
3. LEADS TO BE COPLANAR WITHIN 0.10mm (.004").
4. CONTROLLING DIMENSION: MILLIMETERS.
5. MEETS JEDEC MS012.
6. N = NUMBER OF PINS.

DALLAS SEMICONDUCTOR

PROPRIETARY INFORMATION

TITLE: PACKAGE OUTLINE, .150" SOIC

APPROVAL	DOCUMENT CONTROL NO. 21-0041	REV. B	1/1
----------	---------------------------------	-----------	-----

Maxim cannot assume responsibility for use of any circuitry other than circuitry entirely embodied in a Maxim product. No circuit patent licenses are implied. Maxim reserves the right to change the circuitry and specifications without notice at any time.

12 _____ **Maxim Integrated Products, 120 San Gabriel Drive, Sunnyvale, CA 94086 408-737-7600**

Looking for pricing, stock, or lifecycle information?

Click below to explore more details on WIN SOURCE:

- ⊖ [View MAX4031EEUD+ on WIN SOURCE](#)
- ⊖ [Maxim Integrated Information](#)

Optimize Your Supply Chain with WIN SOURCE Solutions

- ✓ Global Sourcing Solution
- ✓ Obsolete Management
- ✓ Cost Control Management
- ✓ Shortage Management
- ✓ Alternative Solution
- ✓ Excess Inventory Management