



**THE DATASHEET OF  
MAX3892ETH+T**



# +3.3V, 2.5Gbps/2.7Gbps, SDH/SONET 4:1 Serializer with Clock Synthesis

## General Description

The MAX3892 serializer is ideal for converting 4-bit-wide, 622Mbps parallel data to 2.5Gbps serial data in DWDM and SONET/SDH applications. A 4 × 4-bit FIFO allows for any static delay between the parallel output clock and parallel input clock. Delay variation up to a unit interval (UI) is allowed after reset. A fully integrated phase-locked loop (PLL) synthesizes an internal 2.5GHz serial clock from a 622MHz, 155.5MHz, 77.8MHz, or 38.9MHz reference clock. A selectable dual VCO allows excellent jitter performance at both SONET and forward-error correction (FEC) data rates.

Operating from a single 3.3V supply, this device accepts low-voltage differential-signal (LVDS) clock and data inputs for interfacing with high-speed digital circuitry, and delivers current-mode logic (CML) serial data and clock outputs. A loopback data output is provided to facilitate system diagnostic testing. The MAX3892 is available in the extended temperature range (-40°C to +85°C) in 44-pin QFN and TQFN packages.

## Applications

SONET/SDH OC-48 Transmission Systems  
WDM Transponders  
Add/Drop Multiplexers  
Dense Digital Cross-Connects  
Backplane Interconnects

## Features

- ◆ Single +3.3V Supply
- ◆ 455mW Power Consumption
- ◆ 1.4psRMS Maximum Jitter Generation
- ◆ 4 × 4-Bit FIFO Input Buffer
- ◆ 622Mbps/666Mbps Parallel to 2.5Gbps/2.7Gbps Serial Conversion
- ◆ 622MHz/667MHz or 311MHz/333MHz Clock Input
- ◆ On-Chip Clock Synthesizer
- ◆ Multiple Clock Reference Frequencies: (622.08MHz, 155.52MHz, 77.76MHz, 38.88MHz) or (666.51MHz, 166.63MHz, 83.31MHz, 41.66MHz)
- ◆ LVDS Parallel Clock and Data Inputs
- ◆ CML Serial Data and Clock Outputs
- ◆ Additional CML Output for System Loopback Testing

## Ordering Information

PART	TEMP RANGE	PIN-PACKAGE	PKG CODE
MAX3892EGH	-40°C to +85°C	44 QFN	G4477-3
MAX3892ETH+	-40°C to +85°C	44 TQFN	T4477-3

+ Denotes a lead-free package.

## Typical Application Circuit

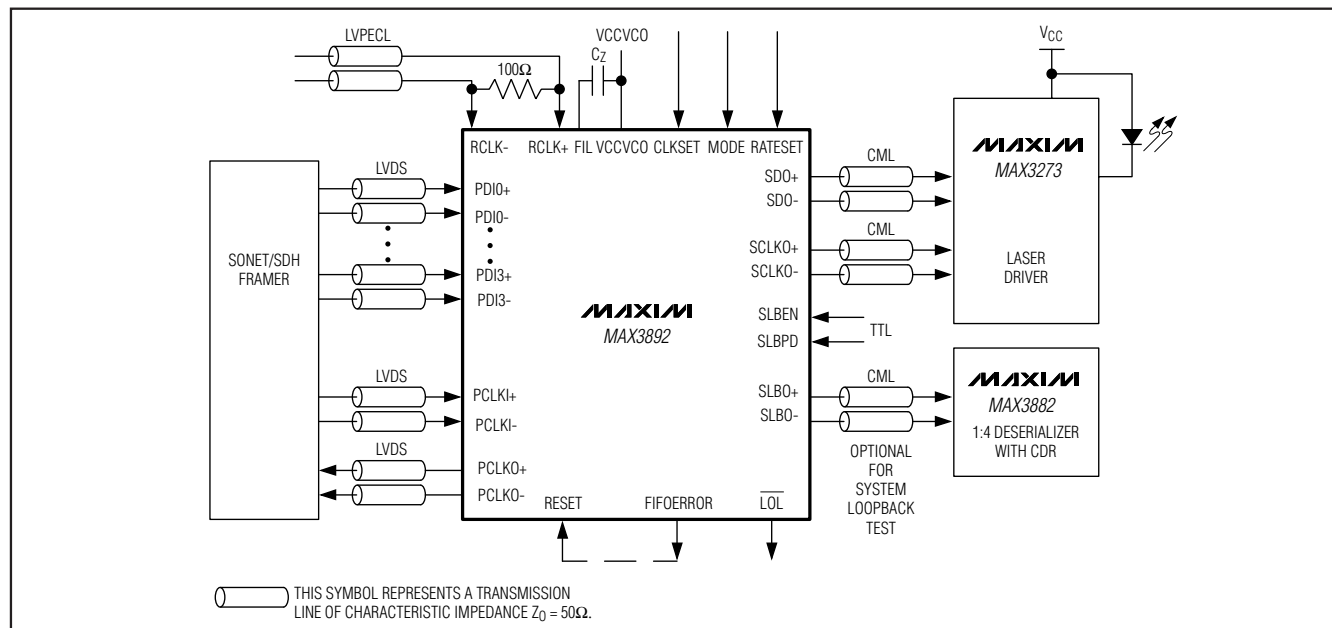

# +3.3V, 2.5Gbps/2.7Gbps, SDH/SONET 4:1 Serializer with Clock Synthesis

## ABSOLUTE MAXIMUM RATINGS

Supply Voltage  $V_{CC}$ ,  $V_{CCO}$ ,  $V_{CCVCO}$  ..... -0.5V to +5V  
 All Inputs and FIL ..... -0.5V to ( $V_{CC} + 0.5V$ )  
 LVDS Output Voltage (PCLKO $\pm$ ) ..... -0.5V to ( $V_{CC} + 0.5V$ )  
 CML Output Current (SDO $\pm$ , SCLKO $\pm$ , SLBO $\pm$ ) ..... 22mA  
 Continuous Power Dissipation ( $T_A = +85^\circ\text{C}$ )  
 44-Pin QFN (derate 25mW/ $^\circ\text{C}$  above +85 $^\circ\text{C}$ ) ..... 1625mW

Operating Temperature Range ..... -40 $^\circ\text{C}$  to +85 $^\circ\text{C}$   
 Storage Temperature Range ..... -55 $^\circ\text{C}$  to +150 $^\circ\text{C}$   
 Lead Temperature (soldering, 10s) ..... +300 $^\circ\text{C}$

Stresses beyond those listed under "Absolute Maximum Ratings" may cause permanent damage to the device. These are stress ratings only, and functional operation of the device at these or any other conditions beyond those indicated in the operational sections of the specifications is not implied. Exposure to absolute maximum rating conditions for extended periods may affect device reliability.

## DC ELECTRICAL CHARACTERISTICS

( $V_{CC} = +3.0V$  to +3.6V,  $T_A = -40^\circ\text{C}$  to +85 $^\circ\text{C}$ . Typical values are at  $V_{CC} = +3.3V$ , differential LVDS load = 100 $\Omega \pm 1\%$ ,  $T_A = +25^\circ\text{C}$ , unless otherwise noted.) (Note 1)

PARAMETER	SYMBOL	CONDITIONS	MIN	TYP	MAX	UNITS
Supply Current	$I_{CC}$	(Note 2)		138	190	mA
<b>LVDS INPUT SPECIFICATIONS</b> (PDI[3..0] $\pm$ , PCLKI $\pm$ )						
Input Voltage Range	$V_I$		0		2400	mV
Differential Input Voltage	$ V_{ID} $		100			mV
Input Common-Mode Current		LVDS input $V_{OS} = 1.2V$		61		$\mu\text{A}$
Threshold Hysteresis				45		mV
Differential Input Resistance	$R_{IN}$		83	100	117	$\Omega$
<b>LVPECL INPUT SPECIFICATIONS</b> (RCLK $\pm$ )						
Input High Voltage	$V_{IH}$		$V_{CC} - 1.16$		$V_{CC} - 0.88$	V
Input Low Voltage	$V_{IL}$		$V_{CC} - 1.81$		$V_{CC} - 1.48$	V
Input Bias Voltage				$V_{CC} - 1.3$		V
Single-Ended Input Resistance				>1.0		k $\Omega$
Differential Input Voltage Swing			300		1900	mV <sub>P-P</sub>
<b>LVDS OUTPUT SPECIFICATIONS</b> (PCLKO $\pm$ )						
Output High Voltage	$V_{OH}$				1.475	V
Output Low Voltage	$V_{OL}$		0.925			V
Differential Output Voltage	$ V_{OD} $		250		400	mV
Change in Magnitude of Differential Output Voltage for Complementary States	$\Delta V_{OD} $				25	mV
Offset Output Voltage			1.125		1.275	V
Change in Magnitude of Output Offset Voltage for Complementary States	$\Delta V_{OS} $				25	mV

# +3.3V, 2.5Gbps/2.7Gbps, SDH/SONET 4:1 Serializer with Clock Synthesis

**MAX3892**

## DC ELECTRICAL CHARACTERISTICS (continued)

( $V_{CC} = +3.0V$  to  $+3.6V$ ,  $T_A = -40^{\circ}C$  to  $+85^{\circ}C$ . Typical values are at  $V_{CC} = +3.3V$ , differential LVDS load =  $100\Omega \pm 1\%$ ,  $T_A = +25^{\circ}C$ , unless otherwise noted.) (Note 1)

PARAMETER	SYMBOL	CONDITIONS	MIN	TYP	MAX	UNITS
Differential Output Resistance			80		140	$\Omega$
Output Current		Shorted together			12	mA
Output Current		Shorted to ground			40	mA
<b>CML OUTPUT SPECIFICATIONS</b> (SDO $\pm$ , SCLKO $\pm$ , SLBO $\pm$ )						
Differential Output		$R_L = 100\Omega$ differential	640	800	1000	mV <sub>P-P</sub>
Differential Output Resistance			83	100	117	$\Omega$
Output Common-Mode Voltage		$R_L = 50\Omega$ to $V_{CC}$		$V_{CC} - 0.2$		V
<b>LVTTL SPECIFICATIONS</b> (RESET, RATESET, SLBEN, SLBPD FIFOERROR, L $\bar{O}L$ )						
Input High Voltage	$V_{IH}$		2.0			V
Input Low Voltage	$V_{IL}$				0.8	V
Input High Current	$I_{IH}$		-30		+10	$\mu A$
Input Low Current	$I_{IL}$		-50		+10	$\mu A$
Output High Voltage	$V_{OH}$	$I_{OH} = 20\mu A$	2.4		$V_{CC}$	V
Output Low Voltage	$V_{OL}$	$I_{OL} = 1mA$			0.4	V
<b>PROGRAMMING INPUTS</b> (CLKSET, MODE)						
Input Current		Input = 0 or $V_{CC}$	-500		+500	$\mu A$

## AC ELECTRICAL CHARACTERISTICS

( $V_{CC} = +3.0V$  to  $+3.6V$ ,  $T_A = -40^{\circ}C$  to  $+85^{\circ}C$ . Typical values are at  $V_{CC} = +3.3V$ , differential LVDS loads =  $100\Omega \pm 1\%$ , CML loads =  $50\Omega \pm 1\%$ ,  $T_A = +25^{\circ}C$ , unless otherwise noted.) (Note 3)

PARAMETER	SYMBOL	CONDITIONS	MIN	TYP	MAX	UNITS
<b>PARALLEL INPUT SPECIFICATIONS</b> (PDI $\pm$ , PCLKI $\pm$ )						
Parallel Input Data Rate		RATESET = GND		622		Mbps
		RATESET = $V_{CC}$		666		
Parallel Input Clock Rate		MODE = OPEN or $V_{CC}$		622		MHz
		MODE = SHORT or $30k\Omega$ to GND		311		
Parallel Input Setup Time	$t_{SU}$	(Note 4)	-94			ps
Parallel Input Hold Time	$t_H$	(Note 4)	300			ps
<b>PARALLEL CLOCK OUTPUT SPECIFICATIONS</b> (PCLKO $\pm$ )						
Parallel Clock Output Rise/Fall Time	$t_r, t_f$	20% to 80%	100		200	ps
Parallel Clock Output Duty Cycle			46		54	%
<b>SERIAL OUTPUT SPECIFICATIONS</b> (SDO $\pm$ , SCLKO $\pm$ )						
Serial Output Data Rate		RATESET = GND		2.488		Gbps
		RATESET = $V_{CC}$		2.666		
Serial Data Output Rise/Fall Time	$t_r, t_f$	20% to 80%			80	ps
Serial Output Clock to Data Delay	$t_{CLK-Q}$	(Note 5)	-25		25	ps

# +3.3V, 2.5Gbps/2.7Gbps, SDH/SONET 4:1 Serializer with Clock Synthesis

## AC ELECTRICAL CHARACTERISTICS (continued)

( $V_{CC} = +3.0V$  to  $+3.6V$ ,  $T_A = -40^{\circ}C$  to  $+85^{\circ}C$ . Typical values are at  $V_{CC} = +3.3V$ , differential LVDS loads =  $100\Omega \pm 1\%$ , CML loads =  $50\Omega \pm 1\%$ ,  $T_A = +25^{\circ}C$ , unless otherwise noted.) (Note 3)

PARAMETER	SYMBOL	CONDITIONS	MIN	TYP	MAX	UNITS
Serial Clock Output Jitter Generation	JG	(Notes 6 and 7)		1.0	1.4	psRMS
Serial Data Output Random Jitter	RJ	(Note 7)			1.4	psRMS
Serial Data Output Deterministic Jitter	DJ	(Note 8)			19	psP-P
<b>REFERENCE CLOCK INPUT SPECIFICATIONS (RCLK)</b>						
Reference Clock Frequency Tolerance			$\pm 100$			ppm
Reference Clock Input Duty Cycle			30		70	%
<b>RESET INPUTS (RESET)</b>						
Minimum Pulse Width of FIFO Reset		UI is PCLKO period		4		UI
Tolerated Drift Between PCLKI and PCLKO After Reset		UI is PCLKO period		$\pm 1$		UI

**Note 1:** Specifications at  $-40^{\circ}C$  are guaranteed by design and characterization.

**Note 2:** Measured with SLBO/CLK622 and SCLK outputs disabled and CML outputs open.

**Note 3:** AC characteristics are guaranteed by design and characterization.

**Note 4:** In 622MHz clock mode, the parallel data is clocked in by the rising edge of the 622MHz/666MHz parallel clock input. In the 311MHz clock mode, the parallel data is clocked in on both the rising and falling edges of the clock. The parallel input setup and hold time increases by 60ps if the duty cycle is between 48% to 52% in 311MHz mode (Figure 1).

**Note 5:** Relative to the falling edge of the SCLKO.

**Note 6:** Measurement bandwidth is  $BW = 12kHz$  to  $20MHz$ .

**Note 7:** Measured with 00001111 pattern, RCLK to PCLKI/PDI[3:0] phase approximately 40ps. See the *Jitter Generation vs. RCLK to PCLK/PDI[3:0] Phase* plot in the *Typical Operating Characteristics* section.

**Note 8:** Deterministic jitter includes pattern-dependent jitter and pulse-width distortion. Measured using a  $2^7 - 1$  PRBS pattern with 96 consecutive identical digits.

# +3.3V, 2.5Gbps/2.7Gbps, SDH/SONET 4:1 Serializer with Clock Synthesis

MAX3892

## Typical Operating Characteristics

( $V_{CC} = +3.3V$ , CML loads AC-coupled to  $50\Omega \pm 1\%$ ,  $T_A = +25^\circ C$ , unless otherwise noted.)

**SUPPLY CURRENT vs. TEMPERATURE**

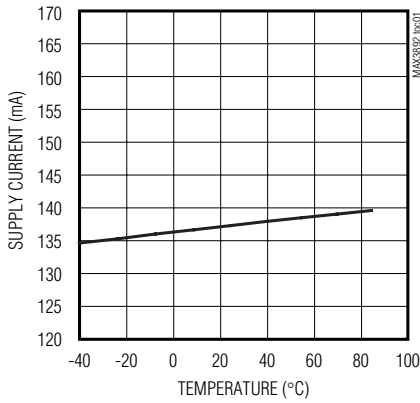

**ELECTRICAL EYE DIAGRAM**

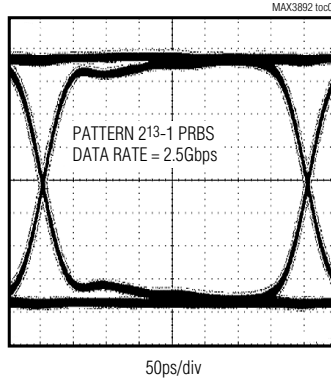

**POWER-SUPPLY JITTER GENERATION vs. RIPPLE FREQUENCY**

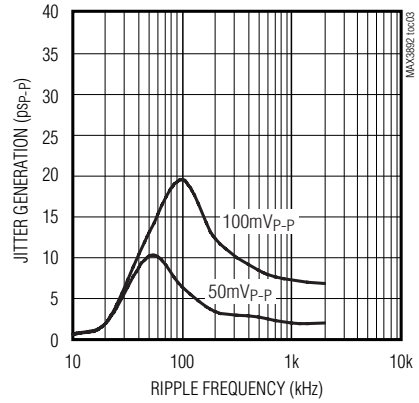

**JITTER GENERATION vs. POWER SUPPLY NOISE AMPLITUDE (BW = 2MHz)**

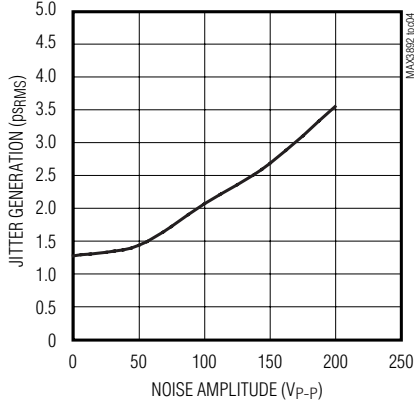

**JITTER GENERATION vs. RCLK to PCLKI/PDI[3:0] PHASE**

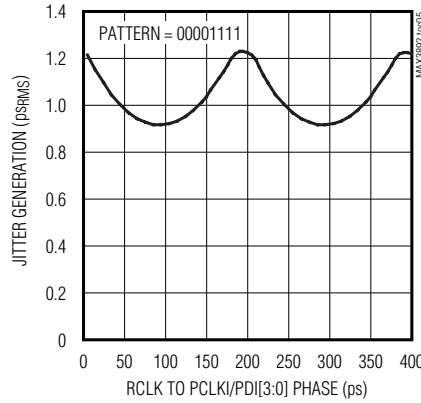

**SERIAL-DATA OUTPUT JITTER**

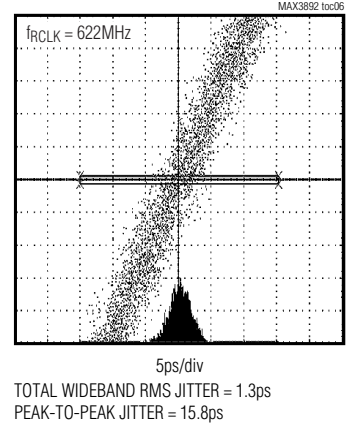

## Pin Description

PIN	NAME	FUNCTION
1, 16, 22, 27, 33, 44	GND	Supply Ground
2, 5, 8, 11	VCCO	Supply Voltage for Outputs +3.3V. Add bypass capacitors near these pins before connecting to the $V_{CC}$ power plane.
3	SCLKO-	Negative Serial Clock Output, CML 2.488GHz or 2.666GHz
4	SCLKO+	Positive Serial Clock Output, CML 2.488GHz or 2.666GHz
6	SDO-	Negative Serial Data Output, CML 2.488Gbps or 2.666Gbps
7	SDO+	Positive Serial Data Output, CML 2.488Gbps or 2.666Gbps

# +3.3V, 2.5Gbps/2.7Gbps, SDH/SONET 4:1 Serializer with Clock Synthesis

## Pin Description (continued)

PIN	NAME	FUNCTION
9	SLBO-	Negative System Loop-Back Output or 622MHz/666MHz Clock Output. Select CML data or clock as shown in Table 1.
10	SLBO+	Positive System Loop-Back Output or 622MHz/666MHz Clock Output. Select CML data or clock as shown in Table 1.
12	SLBPD	System Loopback Power Down, TTL Input. SLPD = high activates the system loopback output driver; SLBPD = low powers down the loop-back output driver.
13	SLBEN	System Loop-Back Enable Input, TTL Input. SLBEN = high activates the system loop-back output; SLBEN = low activates the 622MHz/666MHz reference clock output.
14	RESET	FIFO Reset, TTL Input. An active-high reset recenters the FIFO to tolerate maximum skew between PCLKI and PCKO.
15	FIFOERROR	FIFO Error Indicator, TTL Output. Active high when the read/write clocks access the same FIFO address. This signal may be used to control RESET.
17, 28, 36, 43	V <sub>CC</sub>	Supply Voltage, +3.3V
18	$\overline{\text{LOL}}$	Loss of Lock, TTL Output. An active low indicates that the VCO and reference frequency differ by 500ppm.
19	MODE	Clock Control Input: MODE = GND; f <sub>PCLKI</sub> = 311.04MHz/333MHz with SCLKO active MODE = 30k $\Omega$ to GND; f <sub>PCLKI</sub> = 311.04MHz/333MHz with SCLKO off MODE = OPEN (float); f <sub>PCLKI</sub> = 622.08MHz/666MHz with SCLKO off MODE = V <sub>CC</sub> ; f <sub>PCLKI</sub> = 622.08MHz/666MHz with SCLKO active
20	PCLKI+	Positive Parallel Clock, LVDS Input. Data is written to the input register on the clock rising edge in 622Mbps mode and on both rising and falling edges in 311Mbps mode (Figure 1).
21	PCLKI-	Negative Parallel Clock, LVDS Input (Figure 1).
23, 25, 29, 31	PDI3+ to PDI0+	Positive Data Inputs, LVDS (622Mbps or 666Mbps)
24, 26, 30, 32	PDI3- to PDI0-	Negative Data Inputs, LVDS (622Mbps or 666Mbps)
34	PCKO+	Positive Parallel Clock Output, LVDS. This clock may be 622.08MHz or 666MHz.
35	PCKO-	Negative Parallel Clock Output, LVDS. This clock may be 622.08MHz or 666MHz.
37	RCLK+	Positive Reference Clock Input, LVPECL
38	RCLK-	Negative Reference Clock Input, LVPECL
39	CLKSET	Reference Clock Rate Programming Pin: CLKSET = V <sub>CC</sub> ; RCLK = 622.08MHz/666MHz CLKSET = OPEN (float); RCLK = 155.52MHz/167MHz CLKSET = 30k $\Omega$ to GND; RCLK = 77.76MHz/83.3MHz CLKSET = GND; RCLK = 38.88MHz/41.6MHz
40	RATESET	Data Rate Select, TTL Input. RATESET = high for 2.666Gbps, RATESET = low for 2.488Gbps.
41	VCCVCO	Supply Voltage for VCO +3.3V. Add bypass capacitors near this pin before connecting to the V <sub>CC</sub> power plane.
42	FIL	PLL Capacitor Pin. Connect a 0.1 $\mu$ F capacitor from this pin to VCCVCO.
EP	Exposed Paddle	The exposed paddle must be soldered to ground for proper thermal and electrical operation.

# +3.3V, 2.5Gbps/2.7Gbps, SDH/SONET 4:1 Serializer with Clock Synthesis

## Detailed Description

The MAX3892 converts 4-bit-wide, 622Mbps/667Mbps data to 2.5Gbps/2.7Gbps serial data (Figure 2). Data is loaded into the 4:1 MUX through a 4 × 4-bit FIFO buffer for wide tolerance to clock skew. Clock and data inputs are LVDS levels while high-speed serial outputs are CML. An internal PLL frequency synthesizer generates a serial clock from a low-speed reference clock.

### Low-Voltage Differential-Signal Inputs and Outputs

The MAX3892 has LVDS inputs and outputs for interfacing with high-speed digital circuitry. The LVDS standard is based on the IEEE 1596.3 LVDS specification. This technology uses differential low-voltage swings to achieve fast transition times, minimized power dissipation, and noise immunity. For proper operation, the parallel clock LVDS outputs (PCLKO+, PCLKO-) require 100Ω differential DC termination between the positive and negative outputs. Do not terminate these outputs to ground. The parallel data and parallel clock LVDS inputs (PDI+, PDI-, PCLKI+, PCLKI-) are internally terminated with 100Ω differential input resistance, and therefore do not require external termination.

### PECL Inputs

The reference clock (RCLK+, RCLK-) has PECL inputs for interfacing to a crystal oscillator with AC or DC connections. The RCLK inputs are self-biasing to VCC - 1.3V for AC-coupled inputs. Only a 100Ω differential termination resistance must be added when inputs are AC-coupled.

### Current-Mode Logic Outputs

The 2.5Gbps/2.7Gbps data, clock, and system loop-back outputs (SDO+, SDO-, SCLKO+, SCLKO-, SLBO+, SLBO-) of the MAX3892 are designed using current-mode logic (CML). The configuration of the MAX3892 CML output circuit includes internal 50Ω back termination to VCC (Figure 3). These outputs are intended to drive a 50Ω transmission line terminated with a matched load impedance.

### FIFO Buffer

Data is latched into the MAX3892 by the parallel input clock PCLKI. The parallel input clock serves as the FIFO write clock. The parallel output clock PCLKO acts as the FIFO read clock that loads the 4:1 MUX. The FIFO allows the read and write clocks to vary by up to ±1UI. Conditions that result in the read and write clock accessing the same FIFO address are indicated by

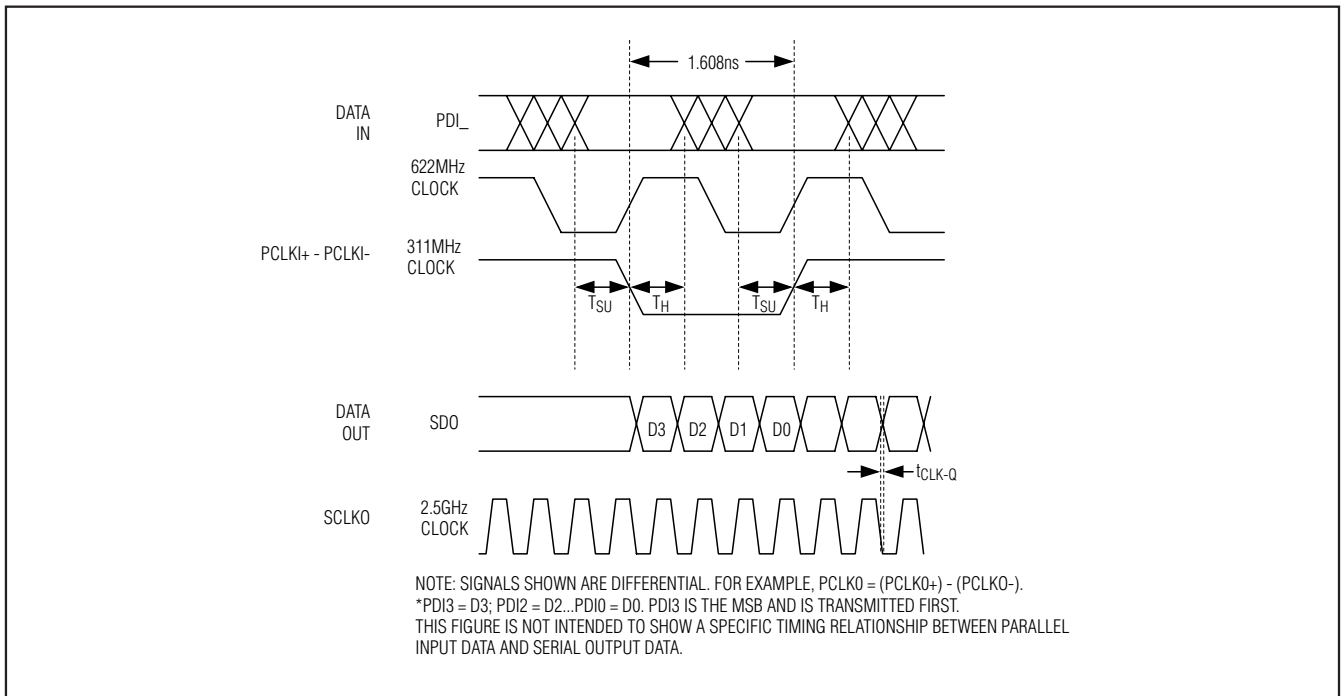

Figure 1. Timing Diagram

# +3.3V, 2.5Gbps/2.7Gbps, SDH/SONET 4:1 Serializer with Clock Synthesis

**Table 1. Loop-Back Operation Mode**

SLBPD	SLBEN	SLBO± OUTPUT
V <sub>IL</sub>	X	Power-Down SLBO Output
V <sub>IH</sub>	V <sub>IL</sub>	622MHz/667MHz Clock Output
V <sub>IH</sub>	V <sub>IH</sub>	2.5Gbps/2.7Gbps System Loop-Back Output

**Table 2. Setting the Reference Clock Frequency**

CLKSET	RATESET	RCLK± FREQUENCY (MHz)
V <sub>CC</sub>	V <sub>CC</sub>	666
	GND	622
OPEN	V <sub>CC</sub>	166.5
	GND	155.52
30kΩ to GND	V <sub>CC</sub>	83.25
	GND	77.76
GND	V <sub>CC</sub>	41.63
	GND	38.88

latching high FIFOERROR. To clear this condition, RESET must be asserted high for at least 4UI. FIFOERROR may be tied directly to the RESET input to recenter the FIFO. After reset, the full elastic range of the FIFO is available again.

### Frequency Synthesizer

The PLL synthesizes a 2.5Gbps/2.7Gbps clock (SCLKO) from an external reference clock. The PLL reference clock (RCLK) may be 622.08MHz/666.53MHz, 155.52MHz/166.6MHz, 77.76MHz/83.3MHz or 38.88MHz/41.65MHz as determined by CLKSET and RATESET. See Table 2 for the reference frequency selection. The parallel output clock PCLKO is also derived from the synthesizer to be SCLKO divided by 4. A TTL-compatible loss-of-lock indicator,  $\overline{\text{LOL}}$ , goes low when the VCO is unable to lock to the reference frequency. Frequency difference on RCLK with respect to the divided down SCLKO greater than 500ppm is indicated by a low state on  $\overline{\text{LOL}}$ . When the frequency difference between the clocks is less than 250ppm,  $\overline{\text{LOL}}$  high indicates a lock condition.

### System Loopback

The MAX3892 is designed to allow system loop-back testing. The loop-back outputs (SLBO+, SLBO-) of the MAX3892 may be directly connected to the loop-back inputs of a deserializer (such as the MAX3882) for system diagnostics. Alternatively, the SLBO pins can be programmed to provide a 622MHz reference clock.

**Table 3. Setting the Clock Mode**

MODE	RATESET	PCLKI± FREQUENCY (MHz)	SCLKO± FREQUENCY (GHz)
V <sub>CC</sub>	V <sub>CC</sub>	666Hz	2.666
	GND	622Hz	2.488
OPEN	V <sub>CC</sub>	666Hz	Disabled
	GND	622Hz	Disabled
30kΩ to GND	V <sub>CC</sub>	333Hz	Disabled
	GND	311Hz	Disabled
GND	V <sub>CC</sub>	333Hz	2.666
	GND	311Hz	2.488

This reference clock can provide a clock hold-over signal to a clock and data recovery (CDR) circuit in the event of loss of signal (LOS).

## Design Procedure

### Clock Mode Selection

The frequencies of the MAX3892 can be set up using CLKSET, RATESET, and MODE as shown in Tables 2 and 3.

### Layout Techniques

For best performance, use good high-frequency layout techniques. Filter voltage supplies and keep ground connections short. Use multiple vias where possible. Also, use controlled-impedance transmission lines to interface with the MAX3892 clock and data inputs and outputs.

### Exposed-Pad Package

The EP 44-pin QFN incorporates features that provide a very low thermal-resistance path for heat removal from the IC to a PC board. The MAX3892's EP must be soldered directly to a ground plane with good thermal conductance.

# +3.3V, 2.5Gbps/2.7Gbps, SDH/SONET 4:1 Serializer with Clock Synthesis

MAX3892

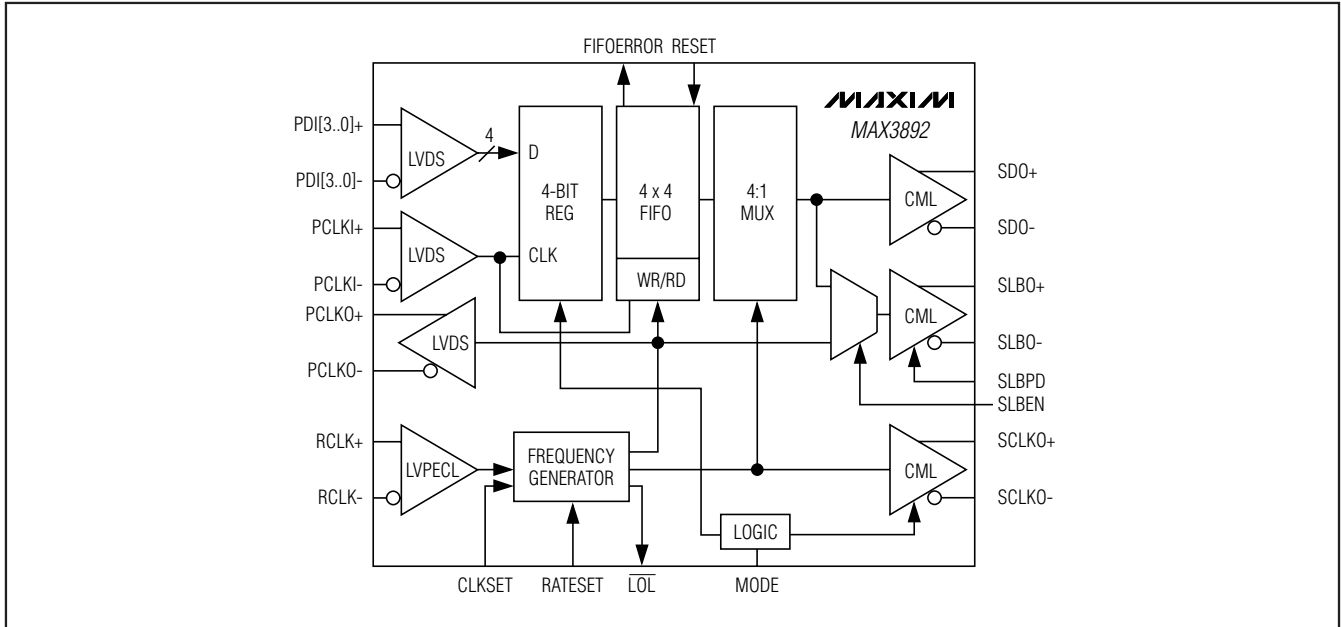

Figure 2. Functional Diagram

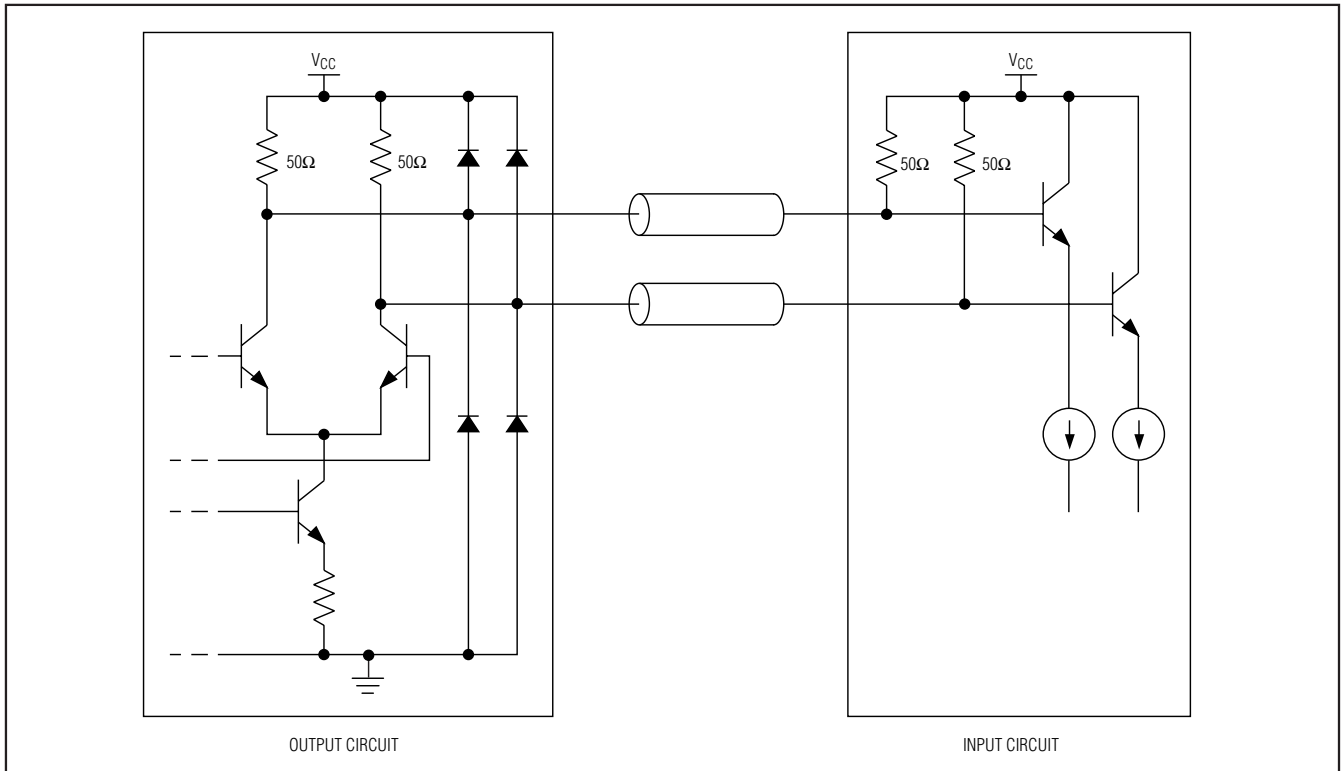

Figure 3. Current-Mode Logic

# +3.3V, 2.5Gbps/2.7Gbps, SDH/SONET 4:1 Serializer with Clock Synthesis

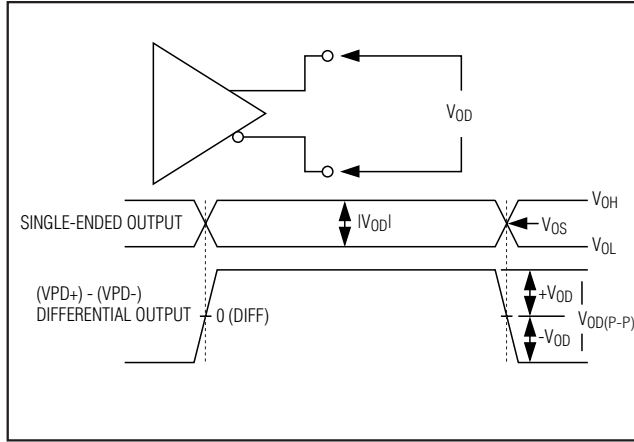
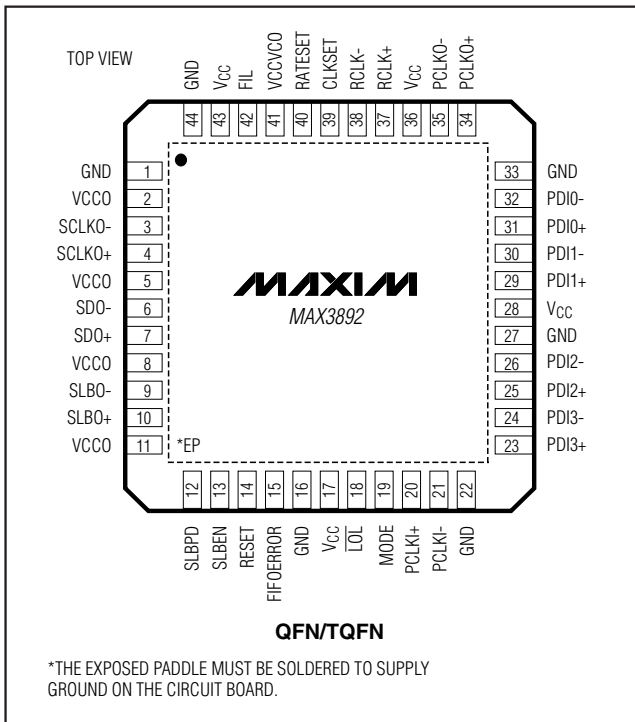

Figure 4. Differential Output Levels

## Pin Configuration



## Chip Information

TRANSISTOR COUNT: 6210

## Package Information

(For the latest package outline information, go to [www.maxim-ic.com/packages](http://www.maxim-ic.com/packages).)

PACKAGE TYPE	DOCUMENT NO.
44 QFN	<a href="#">21-0092</a>
44 TQFN	<a href="#">21-0144</a>

# **+3.3V, 2.5Gbps/2.7Gbps, SDH/SONET 4:1 Serializer with Clock Synthesis**

## **Revision History**

- Rev 0; 11/01: Original data sheet release.
- Rev 1; 5/03: Page 1: added package code; page 11: updated package drawing.
- Rev 2; 3/06: Page 1: updated Typical Application Circuit; page 6: corrected pin numbers for V<sub>CC</sub> and V<sub>CCVCO</sub>; page 10: corrected pin names.
- Rev 3; 6/06: Page 4: updated AC table for JG conditions/typ, PJ conditions, DJ conditions, and added new Note 7; page 5: added new TOC5.
- Rev 4; 12/06: Page 1: removed future status from MAX3882 in Typical Application Circuit; page 5: updated TOC3.
- Rev 5; 2/07: Page 1: added lead-free package to Ordering Information table.
- Rev 6; 10/07: Page 1: clarified that the MAX3892EHT+ is a TQFN package; page 10: added TQFN to the Pin Configuration; pages 11–12: removed package drawings and replaced with package type table.

**MAX3892**

*Maxim cannot assume responsibility for use of any circuitry other than circuitry entirely embodied in a Maxim product. No circuit patent licenses are implied. Maxim reserves the right to change the circuitry and specifications without notice at any time.*

**Maxim Integrated Products, 120 San Gabriel Drive, Sunnyvale, CA 94086 408-737-7600** \_\_\_\_\_ 11

## Looking for pricing, stock, or lifecycle information?

Click below to explore more details on WIN SOURCE:

- ⊖ [View MAX3892ETH+T on WIN SOURCE](#)
- ⊖ [Maxim Integrated Information](#)

## Optimize Your Supply Chain with WIN SOURCE Solutions

- ✓ Global Sourcing Solution
- ✓ Obsolete Management
- ✓ Cost Control Management
- ✓ Shortage Management
- ✓ Alternative Solution
- ✓ Excess Inventory Management