



THE DATASHEET OF MAX384EWN+





Low-Voltage, 8-Channel/Dual 4-Channel Multiplexers with Latchable Inputs

MAX382/MAX384

General Description

The MAX382/MAX384 are low-voltage, CMOS, 1-of-8 and dual 4-channel muxes with latchable digital inputs. They feature low-voltage operation from a +2.7V to +16.5V single supply and from $\pm 3V$ to $\pm 8V$ dual supplies. Pin compatible with the DG428/DG429, these muxes offer low on-resistance (100 Ω max) matched to within 4 Ω max between channels. Additional features include off leakage less than 2.5nA at +85°C and guaranteed low charge injection (10pC max). ESD protection is greater than 2000V per Method 3015.7.

Features

- ◆ Pin-Compatible with Industry-Standard DG428/DG429, DG528/DG529, MAX368/MAX369
- ◆ Single-Supply Operation (+2.7V to +16.5V)
Bipolar Supply Operation ($\pm 3V$ to $\pm 8V$)
- ◆ Low Power Consumption (<300 μW)
- ◆ Low On-Resistance, 100 Ω max
- ◆ Guaranteed On-Resistance Match Between Channels, 4 Ω max
- ◆ Low Leakage, 2.5nA at +85°C
- ◆ TTL/CMOS-Logic Compatible

Applications

- Battery-Operated Systems
- Audio Signal Routing
- Low-Voltage Data-Acquisition Systems
- Sample-and-Hold Circuits
- Automatic Test Equipment

Ordering Information

PART	TEMP. RANGE	PIN-PACKAGE
MAX382CPN	0°C to +70°C	18 Plastic DIP
MAX382CWN	0°C to +70°C	18 Wide SO
MAX382C/D	0°C to +70°C	Dice*
MAX382EPN	-40°C to +85°C	18 Plastic DIP
MAX382EWN	-40°C to +85°C	18 Wide SO
MAX382EJN	-40°C to +85°C	18 CERDIP**
MAX382MJN	-55°C to +125°C	18 CERDIP**

Ordering Information continued on last page.

* Contact factory for dice specifications.

** Contact factory for package availability.

Pin Configurations

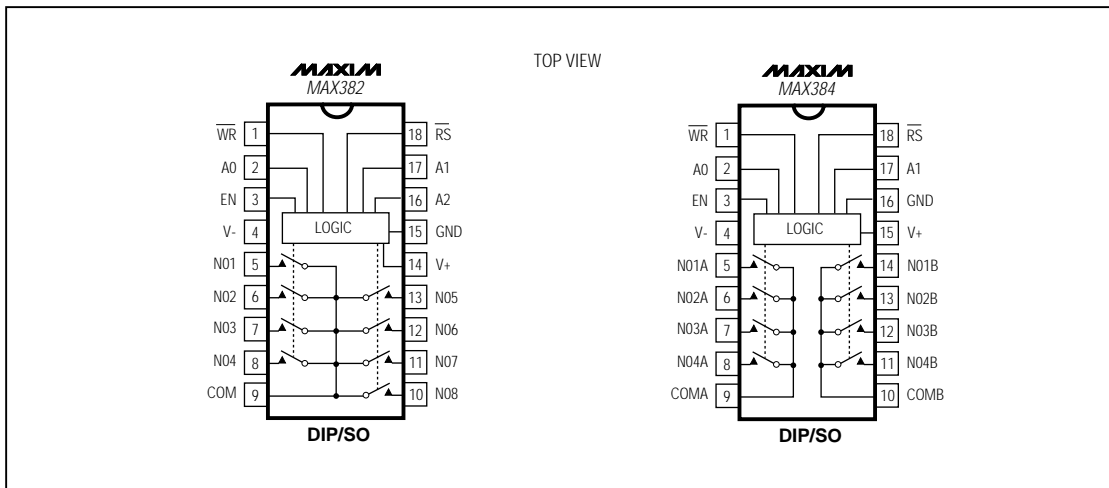

Low-Voltage, 8-Channel/Dual 4-Channel Multiplexers with Latchable Inputs

ABSOLUTE MAXIMUM RATINGS

Voltage Referenced to GND		Continuous Power Dissipation (T _A = +70°C)
V ₊	-0.3V to +17V	Plastic DIP (derate 11.11mW/°C above +70°C)
V ₋	+0.3V to -17V	Wide SO (derate 9.52mW/°C above +70°C)
V ₊ to V ₋	-0.3V to +17V	CERDIP (derate 10.53mW/°C above +70°C)
Voltage into Any Terminal (Note 1)	(V ₋ - 2V) to (V ₊ + 2V) or 30mA (whichever occurs first)	Operating Temperature Ranges
Current into Any Terminal	30mA	MAX38_C_N
Peak Current, Any Terminal (pulsed at 1ms, 10% duty cycle max)	100mA	MAX38_E_N
		MAX38_MJN
		Storage Temperature Range
		Lead Temperature (soldering, 10sec)

Note 1: Signals on any terminal exceeding V₊ or V₋ are clamped by internal diodes. Limit forward current to maximum current ratings.

Stresses beyond those listed under "Absolute Maximum Ratings" may cause permanent damage to the device. These are stress ratings only, and functional operation of the device at these or any other conditions beyond those indicated in the operational sections of the specifications is not implied. Exposure to absolute maximum rating conditions for extended periods may affect device reliability.

ELECTRICAL CHARACTERISTICS—Dual Supplies

(V₊ = +5V ±10%, V₋ = -5V ±10%, GND = 0V, V_{A,H} = V_{ENH} = 2.4V, V_{A,L} = V_{ENL} = 0.8V, \overline{WR} = 0V, \overline{RS} = 2.4V, T_A = T_{MIN} to T_{MAX}, unless otherwise noted.)

PARAMETER	SYMBOL	CONDITIONS		MIN	TYP (Note 2)	MAX	UNITS	
SWITCH								
Analog Signal Range	V _{COM} , V _{NO}	(Note 3)		V ₋		V ₊	V	
Channel On-Resistance	R _{ON}	I _{NO} = 1mA, V _{COM} = ±3.5V	T _A = +25°C	60	100		Ω	
			T _A = T _{MIN} to T _{MAX}		125			
On-Resistance Matching Between Channels (Note 4)	ΔR _{ON}	I _{NO} = 1mA, V _{COM} = ±3.5V, V ₊ = 5V, V ₋ = -5V	T _A = +25°C		4		Ω	
			T _A = T _{MIN} to T _{MAX}		6			
On-Resistance Flatness (Note 5)	R _{FLAT(ON)}	I _{NO} = 1mA, V _{COM} = ±3V, V ₊ = 5V, V ₋ = -5V	T _A = +25°C		10		Ω	
			T _A = T _{MIN} to T _{MAX}		13			
NO-Off Leakage Current (Note 6)	I _{NO(OFF)}	V _{NO} = ±4.5V, V _{COM} = ±4.5V, V ₊ = 5.5V, V ₋ = -5.5V	T _A = +25°C	-0.1	0.1		nA	
			T _A = T _{MIN} to T _{MAX}	C, E	-1.0	1.0		
				M	-10	10		
COM-Off Leakage Current (Note 6)	I _{COM(OFF)}	V _{COM} = ±4.5V, V _{NO} = ±4.5V, V ₊ = 5.5V, V ₋ = -5.5V	MAX382	T _A = +25°C	-0.2	0.2	nA	
				T _A = T _{MIN} to T _{MAX}	C, E	-2.5		2.5
			MAX384		T _A = +25°C	-0.1		0.1
				T _A = T _{MIN} to T _{MAX}	C, E	-1.5		1.5
			MAX384		T _A = T _{MIN} to T _{MAX}	M		-10
				M		-10		10
COM-On Leakage Current (Note 6)	I _{COM(ON)}	V _{COM} = ±4.5V, V _{NO} = 4.5V,	MAX382	T _A = +25°C	-0.4	0.4	nA	
				T _A = T _{MIN} to T _{MAX}	C, E	-5		5
			MAX384		T _A = T _{MIN} to T _{MAX}	M		-40
				MAX384		T _A = +25°C		-0.2
			T _A = T _{MIN} to T _{MAX}		C, E	-2.5		2.5
				MAX384	T _A = T _{MIN} to T _{MAX}	M		-20

Low-Voltage, 8-Channel/Dual 4-Channel Multiplexers with Latchable Inputs

MAX382/MAX384

ELECTRICAL CHARACTERISTICS—Dual Supplies (continued)

(V+ = +5V ±10%, V- = -5V ±10%, GND = 0V, V_{A,H} = V_{ENH} = 2.4V, V_{A,L} = V_{ENL} = 0.8V, WR = 0V, \overline{RS} = 2.4V, T_A = T_{MIN} to T_{MAX}, unless otherwise noted.)

PARAMETER	SYMBOL	CONDITIONS	MIN	TYP (Note 2)	MAX	UNITS	
DIGITAL LOGIC INPUT							
Logic High Input Voltage	V _{A,H} , V _{ENH}		T _A = T _{MIN} to T _{MAX}		2.4	V	
Logic Low Input Voltage	V _{A,L} , V _{ENL}		T _A = T _{MIN} to T _{MAX}		0.8	V	
Input Current with Input Voltage High	I _{A,H} , I _{ENH}	V _{A,H} = 2.4V, V _{A,L} = 0.8V	-0.1		0.1	μA	
Input Current with Input Voltage Low	I _{A,L} , I _{ENL}	V _{A,H} = 2.4V, V _{A,L} = 0.8V	-0.1		0.1	μA	
SUPPLY							
Power-Supply Range	V+, V-		±2.4		±8	V	
Positive Supply Current	I+	V _{EN} = V _A = 0V/V+, V+ = 5.5V, V- = -5.5V	T _A = +25°C		-1	1	μA
Negative Supply Current	I-	V _{EN} = V _A = 0V/V+, V+ = 5.5V, V- = -5.5V	T _A = T _{MIN} to T _{MAX}		-1	1	μA
AX, EN Data Hold Time	t _H	Figure 5	T _A = +25°C		100	ns	
Reset Pulse Width	t _{RS}	Figure 6, V+ = 5V	T _A = +25°C		100	ns	
DYNAMIC							
Transition Time	t _{TRANS}	Figure 1		100	275	ns	
Break-Before-Make Interval	t _{OPEN}	Figure 2	T _A = +25°C		0	20	ns
Enable Turn-On Time	t _{ON(EN)}	Figure 3	T _A = +25°C		100	150	ns
			T _A = T _{MIN} to T _{MAX}			250	
Enable Turn-Off Time	t _{OFF(EN)}	Figure 3	T _A = +25°C		80	150	ns
			T _A = T _{MIN} to T _{MAX}			250	
Write Turn-On Time	t _{ON(WR)}	Figure 4	T _A = +25°C			150	ns
			T _A = T _{MIN} to T _{MAX}			250	
Reset Turn-Off Time	t _{OFF(RS)}	Figure 6	T _A = +25°C			150	ns
			T _A = T _{MIN} to T _{MAX}			250	
Charge Injection (Note 3)	V _{CTE}	C _L = 100pF, V _{NO} = 0V	T _A = +25°C		2	5	pC
Off Isolation (Note 7)	V _{ISO}	V _{EN} = 0V, R _L = 1kΩ, f = 100kHz	T _A = +25°C		-75		dB
Crosstalk Between Channels	V _{CT}	V _{EN} = 2.4V, f = 100kHz, V _{GEN} = 1V _{p-p} , R _L = 1kΩ	T _A = +25°C		-92		dB
Logic Input Capacitance	C _{IN}	f = 1MHz	T _A = +25°C		8		pF
NO-Off Capacitance	C _{NO(OFF)}	f = 1MHz, V _{EN} = V _{COM} = 0V	T _A = +25°C		11		pF
COM-Off Capacitance	C _{COM(OFF)}	f = 1MHz, V _{EN} = V _{COM} = 0V	MAX382	T _A = +25°C		40	pF
			MAX384			20	
COM-On Capacitance	C _{COM(ON)}	f = 1MHz, V _{EN} = V _{COM} = 0V	MAX382	T _A = +25°C		54	pF
			MAX384			34	
MINIMUM INPUT TIMING REQUIREMENTS							
Write Pulse Width	t _W	Figure 5	T _A = +25°C		100		ns
AX, EN Data Setup Time	t _S	Figure 5	T _A = +25°C		100		ns

Low-Voltage, 8-Channel/Dual 4-Channel Multiplexers with Latchable Inputs

ELECTRICAL CHARACTERISTICS—Single +5V Supply

($V_+ = +5V \pm 10\%$, $V_- = 0V$, $GND = 0V$, $V_{A_H} = V_{ENH} = 2.4V$, $V_{A_L} = V_{ENL} = 0.8V$, $\overline{WR} = 0V$, $\overline{RS} = 2.4V$, $T_A = T_{MIN}$ to T_{MAX} , unless otherwise noted.)

PARAMETER	SYMBOL	CONDITIONS		MIN	TYP (Note 2)	MAX	UNITS	
AX, EN Data Hold Time	t_H	Figure 5		$T_A = +25^\circ C$		100	ns	
Reset Pulse Width	t_{RS}	Figure 6, $V_+ = 5V$		$T_A = +25^\circ C$		100	ns	
SWITCH								
Analog Signal Range	V_{COM}, V_{NO}	(Note 3)		V_-		V_+	V	
On-Resistance	R_{ON}	$I_{NO} = 1mA, V_{COM} = 3.5V, V_+ = 4.5V$		$T_A = +25^\circ C$		150	225	Ω
				$T_A = T_{MIN}$ to T_{MAX}			280	
On-Resistance Matching Between Channels (Note 4)	ΔR_{ON}	$I_{NO} = 1mA, V_{COM} = 3.5V, V_+ = 4.5V$		$T_A = +25^\circ C$			10	Ω
				$T_A = T_{MIN}$ to T_{MAX}			12	
On-Resistance Flatness	R_{FLAT}	$I_{NO} = 1mA; V_{COM} = 3V, 2V, 1V; V_+ = 5V$		$T_A = +25^\circ C$		10	16	Ω
				$T_A = T_{MIN}$ to T_{MAX}		15	20	
NO-Off Leakage Current (Note 8)	$I_{NO(OFF)}$	$V_{NO} = 4.5V, V_{COM} = 0V, V_+ = 5.5V$		$T_A = +25^\circ C$		-0.1	0.1	nA
				$T_A = T_{MIN}$ to T_{MAX}	C, E	-1.0	1.0	
					M	-10	10	
COM-Off Leakage Current (Note 8)	$I_{COM(OFF)}$	$V_{COM} = 4.5V, V_{NO} = 0V, V_+ = 5.5V$	MAX382	$T_A = +25^\circ C$		-0.2	0.2	nA
				$T_A = T_{MIN}$ to T_{MAX}	C, E	-2.5	2.5	
					M	-20	20	
		$V_{COM} = 4.5V, V_{NO} = 0V, V_+ = 5.5V$	MAX384	$T_A = +25^\circ C$		-0.2	0.2	
				$T_A = T_{MIN}$ to T_{MAX}	C, E	-1.5	1.5	
					M	-10	10	
COM-On Leakage Current (Note 8)	$I_{COM(ON)}$	$V_{COM} = 4.5V, V_{NO} = 4.5V, V_+ = 5.5V$	MAX382	$T_A = +25^\circ C$		-0.4	0.4	nA
				$T_A = T_{MIN}$ to T_{MAX}	C, E	-5	5	
					M	-40	40	
		$V_{COM} = 4.5V, V_{NO} = 4.5V, V_+ = 5.5V$	MAX384	$T_A = +25^\circ C$		-0.2	0.2	
				$T_A = T_{MIN}$ to T_{MAX}	C, E	-2.5	2.5	
					M	-20	20	
DIGITAL LOGIC INPUT								
Logic High Input Voltage	V_H, V_{ENH}			$T_A = T_{MIN}$ to T_{MAX}		2.4	V	
Logic Low Input Voltage	V_L, V_{ENL}			$T_A = T_{MIN}$ to T_{MAX}		0.8	V	
Input Current with Input Voltage High	I_H, I_{ENH}	$V_H = 2.4V, V_L = 0.8V$				-0.1	0.1	μA
Input Current with Input Voltage Low	I_L, I_{ENL}	$V_H = 2.4V, V_L = 0.8V$				-0.1	0.1	μA
SUPPLY								
Power-Supply Range				2.4		15	V	
Positive Supply Current	I_+	$V_{EN} = V_A = 0V, V_+; V_+ = 5.5V; V_- = 0V$		-1.0		1.0	μA	
Negative Supply Current	I_-	$V_{EN} = V_A = 0V, V_+; V_+ = 5.5V; V_- = 0V$		-1.0		1.0	μA	
I_{GND} Supply Current	I_{GND}	$V_{EN} = V_+, 0V; V_A = 0V; V_+ = 5.5V; V_- = 0V$		$T_A = +25^\circ C$		-1.0	1.0	μA
				$T_A = T_{MIN}$ to T_{MAX}		-1.0	1.0	

Low-Voltage, 8-Channel/Dual 4-Channel Multiplexers with Latchable Inputs

MAX382/MAX384

ELECTRICAL CHARACTERISTICS—Single +5V Supply (continued)

(V₊ = +5V ±10%, V₋ = 0V, GND = 0V, V_{A,H} = V_{ENH} = 2.4V, V_{A,L} = V_{ENL} = 0.8V, \overline{WR} = 0V, \overline{RS} = 2.4V, T_A = T_{MIN} to T_{MAX}, unless otherwise noted.)

PARAMETER	SYMBOL	CONDITIONS	MIN	TYP (Note 2)	MAX	UNITS
DYNAMIC						
Transition Time	t _{TRANS}	Figure 1, V _{NO} = 3V		90	280	ns
Break-Before-Make Interval	t _{OPEN}	Figure 2 (Note 3)	T _A = +25°C	5	40	ns
Enable Turn-On Time (Note 3)	t _{ON(EN)}	Figure 3	T _A = +25°C	130	200	ns
			T _A = T _{MIN} to T _{MAX}		275	
Enable Turn-Off Time (Note 3)	t _{OFF(EN)}	Figure 3	T _A = +25°C	80	200	ns
			T _A = T _{MIN} to T _{MAX}		275	
Write Turn-On Time (Note 3)	t _{ON(\overline{WR})}}	Figure 4	T _A = +25°C		200	ns
			T _A = T _{MIN} to T _{MAX}		275	
Reset Turn-Off Time (Note 3)	t _{OFF(\overline{RS})}}	Figure 4	T _A = +25°C		200	ns
			T _A = T _{MIN} to T _{MAX}		275	
Charge Injection (Note 3)	V _{CTE}	Figure 7, C _L = 100pF, V _{NO} = 0V	T _A = +25°C	1.5	5	pC

ELECTRICAL CHARACTERISTICS—Single +3V Supply

(V₊ = +3V ±10%, V₋ = 0V, GND = 0V, V_{A,H} = V_{ENH} = 2.4V, V_{A,L} = V_{ENL} = 0.8V, \overline{WR} = 0V, \overline{RS} = 2.4V, T_A = T_{MIN} to T_{MAX}, unless otherwise noted.)

PARAMETER	SYMBOL	CONDITIONS	MIN	TYP (Note 2)	MAX	UNITS
SWITCH						
Analog Signal Range	V _{ANALOG}	(Note 3)	V ₋		V ₊	V
On-Resistance	R _{ON}	I _{NO} = 1mA, V _{COM} = 1.5V, V ₊ = 3V	T _A = +25°C	230	375	Ω
			T _A = T _{MIN} to T _{MAX}		425	
DYNAMIC						
Transition Time (Note 3)	t _{TRANS}	Figure 1, V _{IN} = 2.4V, V _{NO1} = 1.5V, V _{NO8} = 0V	T _A = +25°C	230	575	ns
Enable Turn-On Time (Note 3)	t _{ON(EN)}	Figure 3, V _{INH} = 2.4V, V _{INL} = 0V, V _{NO1} = 1.5V	T _A = +25°C	200	500	ns
Enable Turn-Off Time (Note 3)	t _{OFF(EN)}	Figure 3, V _{INH} = 2.4V, V _{INL} = 0V, V _{NO1} = 1.5V	T _A = +25°C	75	400	ns
Write Turn-On Time (Note 3)	t _{ON(\overline{WR})}}	Figure 4	T _A = +25°C	200	500	ns
Reset Turn-Off Time (Note 3)	t _{OFF(\overline{RS})}}	Figure 4	T _A = +25°C	75	400	ns
Charge Injection (Note 3)	V _{CTE}	Figure 7, C _L = 100pF, V _{NO} = 0V	T _A = +25°C	1	5	pC

Note 2: The algebraic convention, where the most negative value is a minimum and the most positive value a maximum, is used in this data sheet.

Note 3: Guaranteed by design.

Note 4: ΔR_{ON} = R_{ON(max)} - R_{ON(min)}.

Note 5: Flatness is defined as the difference between the maximum and minimum value of on-resistance as measured over the specified analog signal ranges, i.e., V_{NO} = 3V to 0V and 0V to -3V.

Note 6: Leakage parameters are 100% tested at maximum rated hot operating temperature, and guaranteed by correlation at +25°C.

Note 7: Worst-case isolation is on channel 4 because of its proximity to the COM pin. Off isolation = 20log V_{COM}/V_{NO}, V_{COM} = output, V_{NO} = input to off switch.

Note 8: Leakage testing at single supply is guaranteed by correlation testing with dual supplies.

Low-Voltage, 8-Channel/Dual 4-Channel Multiplexers with Latchable Inputs

Typical Operating Characteristics

($T_A = +25^\circ\text{C}$, unless otherwise noted.)

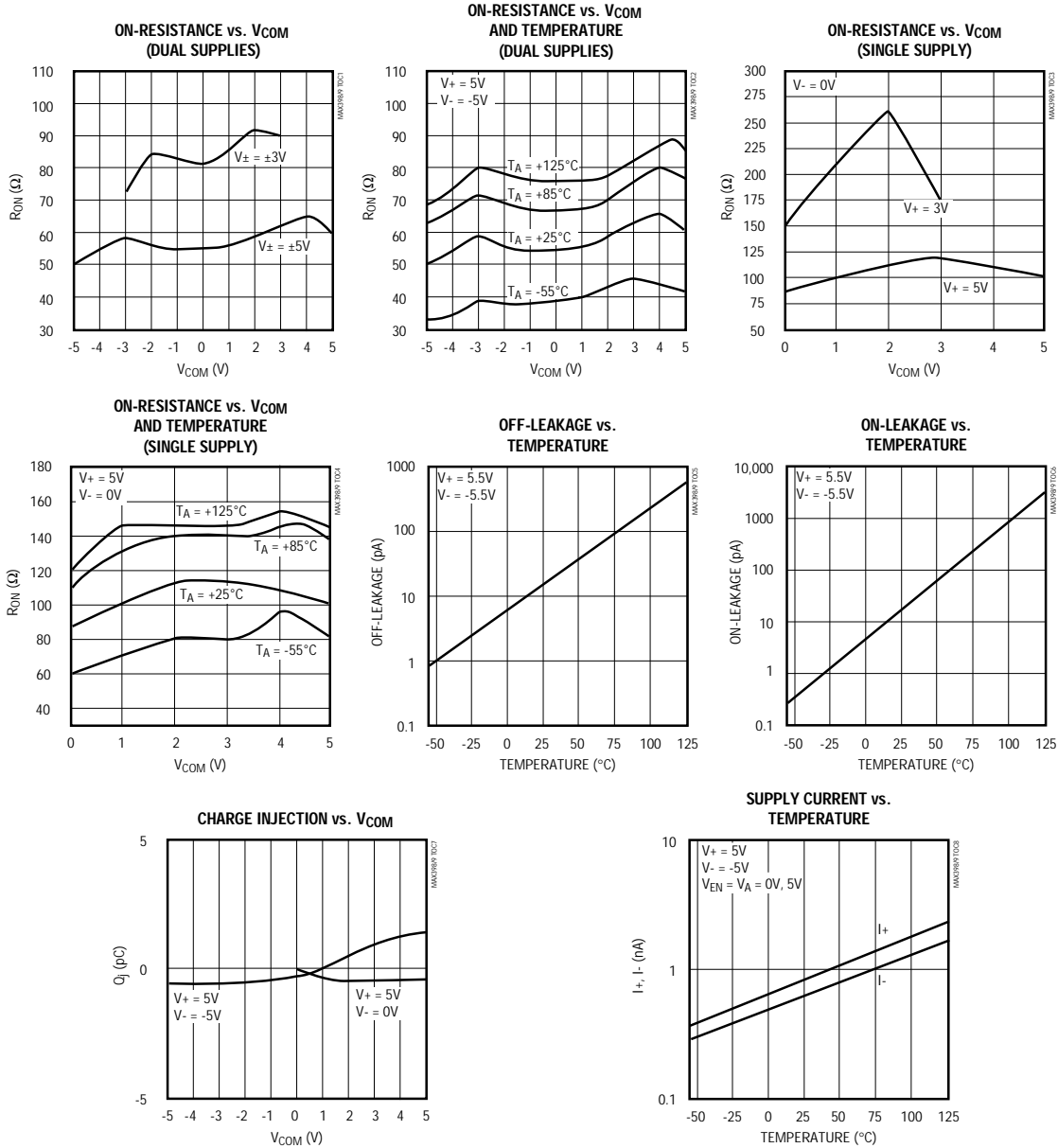

Low-Voltage, 8-Channel/Dual 4-Channel Multiplexers with Latchable Inputs

Pin Description

MAX382/MAX384

PIN		NAME*	FUNCTION
MAX382	MAX384		
1	1	\overline{WR}	WRITE Logic Input
2, 16, 17	—	A0, A2, A1	Address Logic Inputs (see <i>Truth Tables</i> at end of data sheet)
—	2, 17	A0, A1	Address Logic Inputs (see <i>Truth Tables</i> at end of data sheet)
3	3	EN	Enable Logic Input (see <i>Truth Tables</i> at end of data sheet)
4	4	V-	Negative Supply Voltage Input. Connect to GND for single-supply operation.
5–8	—	NO1–NO4	Analog Signal Inputs—bidirectional
—	5–8	NO1A–NO4A	Analog Signal Inputs—bidirectional
9	—	COM	Analog Signal Output—bidirectional
—	9, 10	COMA, COMB	Analog Signal Outputs—bidirectional
10–13	—	NO8–NO5	Analog Signal Inputs—bidirectional
—	11–14	NO4B–NO1B	Analog Signal Inputs—bidirectional
14	15	V+	Positive Supply Voltage Input
15	16	GND	Ground
18	18	\overline{RS}	RESET Logic Input

*Analog inputs and outputs are names of convenience only. Inputs and outputs are identical and interchangeable.

Applications Information

The internal structures of the MAX382/MAX384 include translators for the A2/A1/EN/ \overline{WR} / \overline{RS} digital inputs, latches, and a decode section for channel selection (see *Truth Tables*). The analog-signal switches consist of parallel combinations of N and P MOSFETs.

WRITE (\overline{WR}) and RESET (\overline{RS}) strobes are provided for interfacing with μ P-bus lines, alleviating the need for the μ P to provide constant address inputs to the mux to hold a particular channel (Figures 2–7).

When the \overline{WR} strobe is in the low state (less than 0.8V) and the \overline{RS} strobe is in the high state (greater than 2.4V), the muxes are in the transparent mode—they act similar to nonlatching devices, such as the MAX398/MAX399.

When the \overline{WR} goes high, the previous BCD address input is latched and held in that state indefinitely.

\overline{RS} turns off all channels when it is low. All switches stay off until \overline{RS} and EN are high and \overline{WR} is low.

The MAX382/MAX384 work with both single and dual supplies and function over the +2.4V to +16V single-supply range. For example, with a single +5V power supply, analog signals in the 0V to +5V range can be switched normally. If negative signals around 0V are expected, a negative supply is needed.

The EN latch allows all switches to be turned off under program control. This is useful when two or more are cascaded to build 16-line and larger analog-signal multiplexers.

Low-Voltage, 8-Channel/Dual 4-Channel Multiplexers with Latchable Inputs

Test Circuits/Timing Diagrams

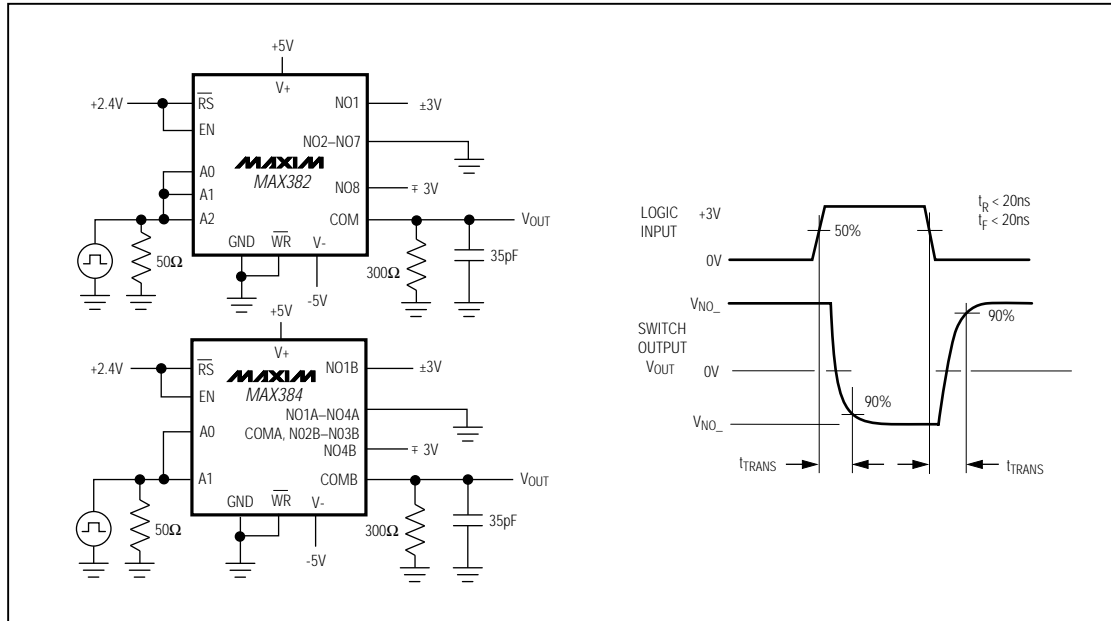

Figure 1. Transition Time

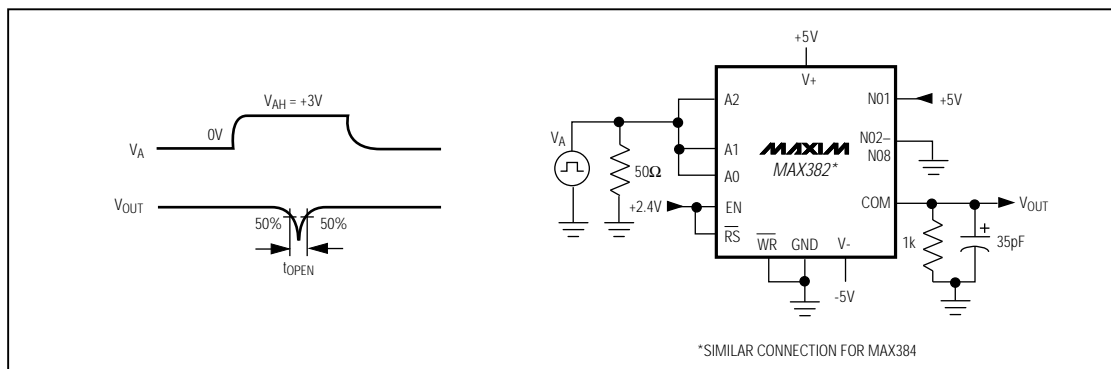

Figure 2. Break-Before-Make Interval (t_{OPEN})

Low-Voltage, 8-Channel/Dual 4-Channel Multiplexers with Latchable Inputs

MAX382/MAX384

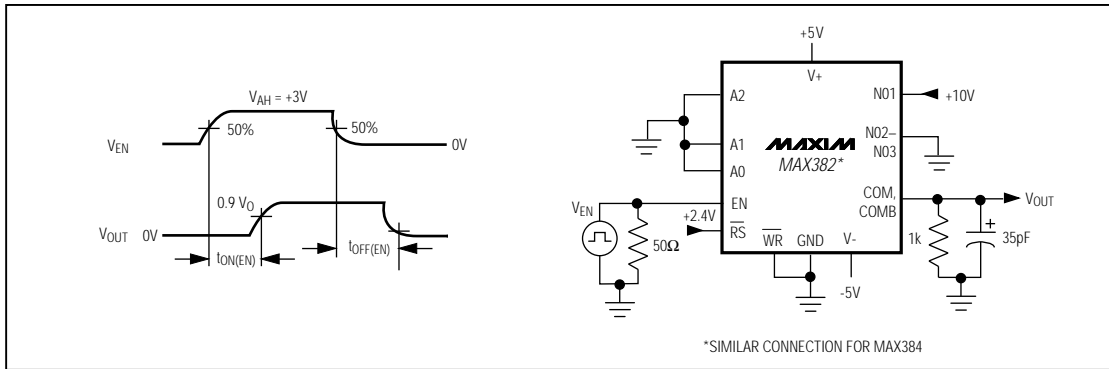

Figure 3. Enable Delay ($t_{ON}(EN)$, $t_{OFF}(EN)$)

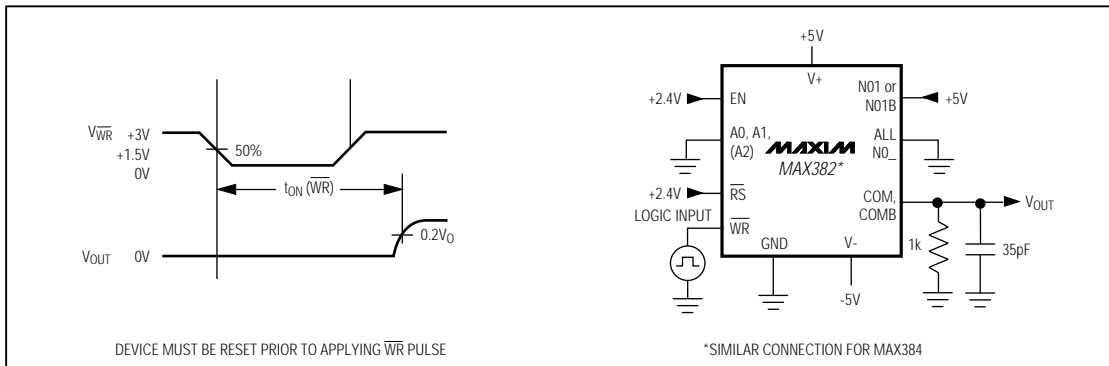

Figure 4. Write Turn-On Time ($t_{ON}(\overline{WR})$)

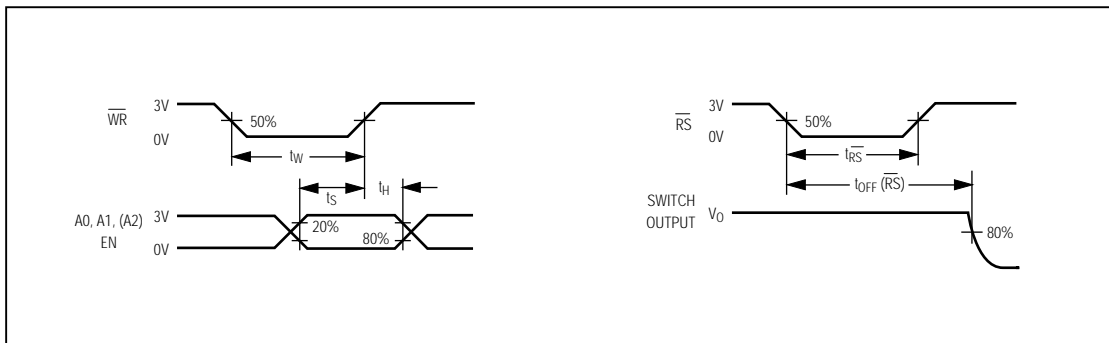

Figure 5. Write, Setup, and Hold Timing (t_w , t_s , t_h)

Low-Voltage, 8-Channel/Dual 4-Channel Multiplexers with Latchable Inputs

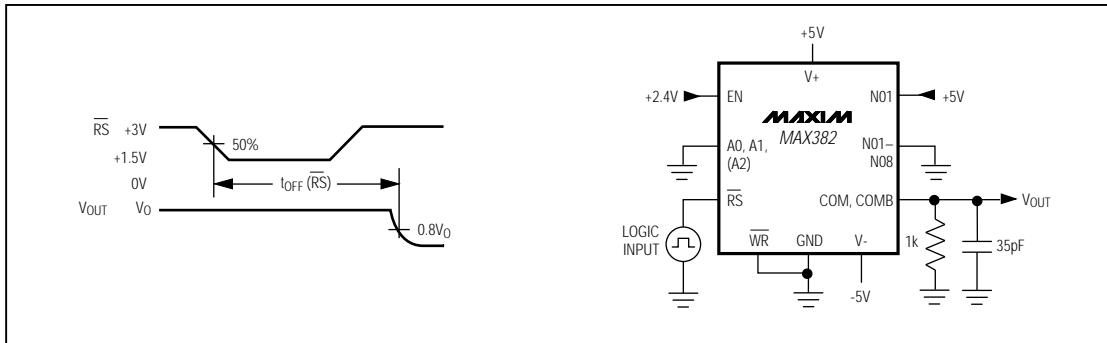

Figure 6. Reset Turn-Off Time ($t_{OFF}(\overline{RS})$)

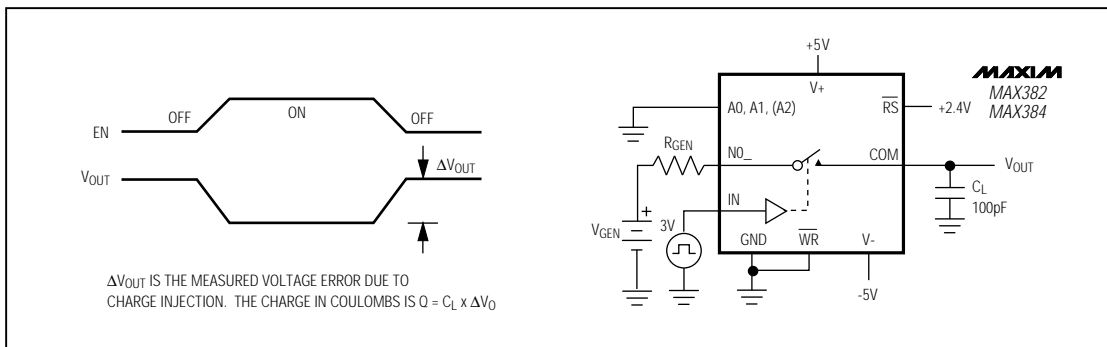

Figure 7. Charge Injection (V_{CTE})

Operation with Supply Voltages Other than $\pm 5V$

Using supply voltages less than $\pm 5V$ reduces the analog signal range. The MAX382/MAX384 muxes operate with $\pm 3V$ to $\pm 8V$ bipolar supplies or with a +2.7V to +16.5V single supply. Connect V- to GND when operating with a single supply. Both devices can also operate with unbalanced supplies, such as +10V and -5V. The *Typical Operating Characteristics* graphs show typical on-resistance with $\pm 3V$, $\pm 5V$, +3V and +5V supplies. (Switching times increase by a factor of two or more for operation at +5V or below.)

Overvoltage Protection

Proper power-supply sequencing is recommended for all CMOS devices. Do not exceed the absolute maximum ratings, because stresses beyond the listed ratings can cause permanent damage to the devices. Always sequence V+ on first, then V-, followed by the logic inputs, NO, or COM. If power-supply sequencing is not possible, add two small signal diodes (D1, D2) in series with supply pins for overvoltage protection (Figure 8). Adding diodes reduces the analog signal range to one diode drop below V+ and one diode drop above V-, but does not affect the devices' low switch resistance and low leakage characteristics. Device operation is unchanged, and the difference between V+ and V- should not exceed 17V. These protection diodes are not recommended when using a single supply.

Low-Voltage, 8-Channel/Dual 4-Channel Multiplexers with Latchable Inputs

MAX382/MAX384

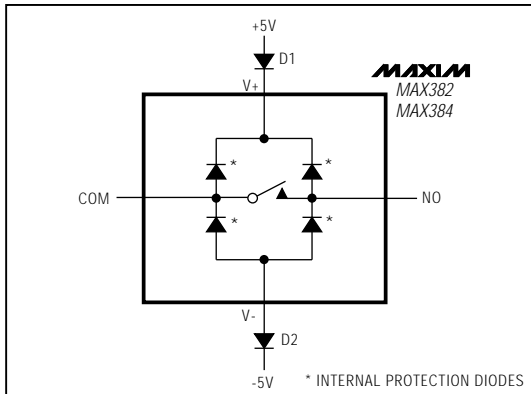

Figure 8. Overvoltage Protection Using External Blocking Diodes

Functional Diagrams/Truth Tables

MAX382 8-CHANNEL SINGLE-ENDED MULTIPLEXER

A2	A1	A0	EN	\overline{WR}	\overline{RS}	ON SWITCH
Latching						
X	X	X	X	\uparrow	1	Maintains previous switch condition
Reset						
X	X	X	X	X	0	NONE (latches cleared)
Transparent Operation						
X	X	X	0	0	1	NONE
0	0	0	1	0	1	1
0	0	1	1	0	1	2
0	1	0	1	0	1	3
0	1	1	1	0	1	4
1	0	0	1	0	1	5
1	0	1	1	0	1	6
1	1	0	1	0	1	7
1	1	1	1	0	1	8

MAX384 DIFFERENTIAL 4-CANNEL MULTIPLEXER

A1	A0	EN	\overline{WR}	\overline{RS}	ON SWITCH
Latching					
X	X	X	\uparrow	1	Maintains previous switch condition
Reset					
X	X	X	X	0	NONE (latches cleared)
Transparent Operation					
X	X	0	0	1	NONE
0	0	1	0	1	1
0	1	1	0	1	2
1	0	1	0	1	3
1	1	1	0	1	4

LOGIC "0" = $V_{AL} \leq 0.8V$, LOGIC "1" = $V_{AH} \geq 2.4V$

Low-Voltage, 8-Channel/Dual 4-Channel Multiplexers with Latchable Inputs

_Ordering Information (continued)

PART	TEMP. RANGE	PIN-PACKAGE
MAX384CPN	0°C to +70°C	18 Plastic DIP
MAX384CWN	0°C to +70°C	18 Wide SO
MAX384C/D	0°C to +70°C	Dice*
MAX384EPN	-40°C to +85°C	18 Plastic DIP
MAX384EWN	-40°C to +85°C	18 Wide SO
MAX384EJN	-40°C to +85°C	18 CERDIP**
MAX384MJN	-55°C to +125°C	18 CERDIP**

* Contact factory for dice specifications.

** Contact factory for package availability.

Chip Topographies

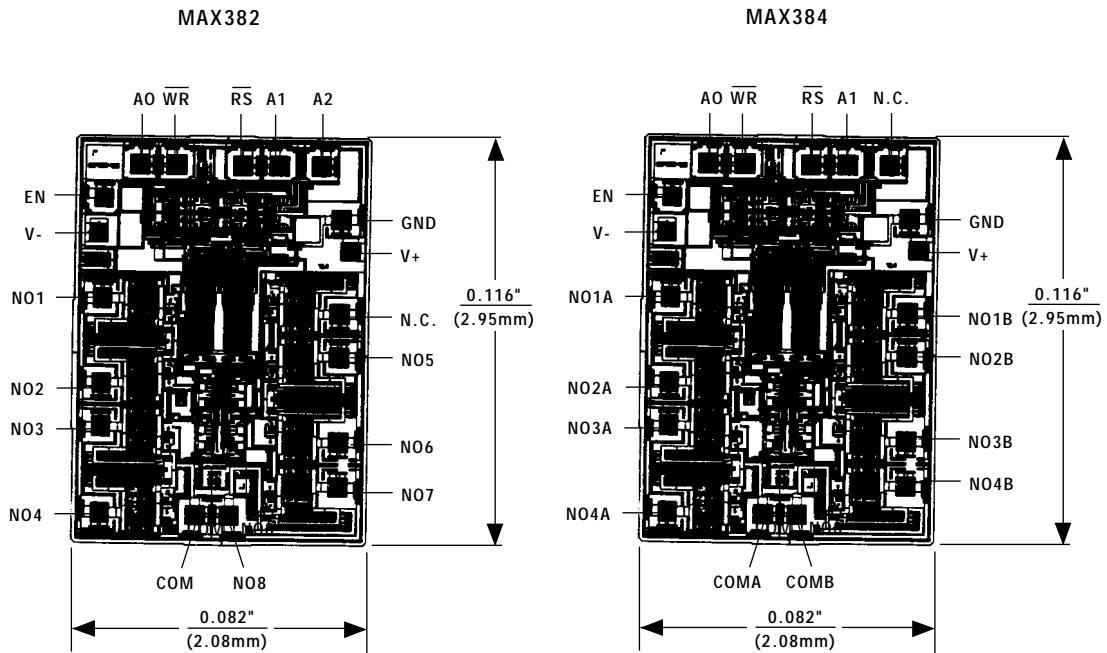

TRANSISTOR COUNT: 165
SUBSTRATE CONNECTED TO V+

Maxim cannot assume responsibility for use of any circuitry other than circuitry entirely embodied in a Maxim product. No circuit patent licenses are implied. Maxim reserves the right to change the circuitry and specifications without notice at any time.

12 _____ Maxim Integrated Products, 120 San Gabriel Drive, Sunnyvale, CA 94086 (408) 737-7600

© 1995 Maxim Integrated Products

Printed USA

MAXIM is a registered trademark of Maxim Integrated Products.

Looking for pricing, stock, or lifecycle information?

Click below to explore more details on WIN SOURCE:

 [View MAX384EWN+ on WIN SOURCE](#)

 [Maxim Integrated Information](#)

Optimize Your Supply Chain with WIN SOURCE Solutions

-  Global Sourcing Solution
-  Obsolete Management
-  Cost Control Management
-  Shortage Management
-  Alternative Solution
-  Excess Inventory Management