



**THE DATASHEET OF
MAX1793EUE50+**





Low-Dropout, Low IQ, 1A Linear Regulator

MAX1793

General Description

The MAX1793 low-dropout linear regulator (LDO) operates from +2.5V to +5.5V and delivers a guaranteed 1A load current with a low 210mV dropout. The high-accuracy ($\pm 1\%$) output voltage is preset at an internally trimmed voltage (see the *Ordering Information*) or can be adjusted from 1.25V to 5.0V with an external resistor-divider.

An internal pMOS pass transistor allows a low 125 μ A supply current, making the MAX1793 ideal for battery-operated portable equipment. Other features include a built-in reset output, low-power shutdown, and short-circuit and thermal-overload protection. The MAX1793 is available in a 1.5W, 16-pin power TSSOP package, which is 30% smaller than a SOT223 package and only 1.1mm high.

Applications

Notebook Computers
Cordless Telephones
Cellular Phones
Modems
Handheld Instruments
PDAs and Palmtop Computers

Typical Operating Circuit

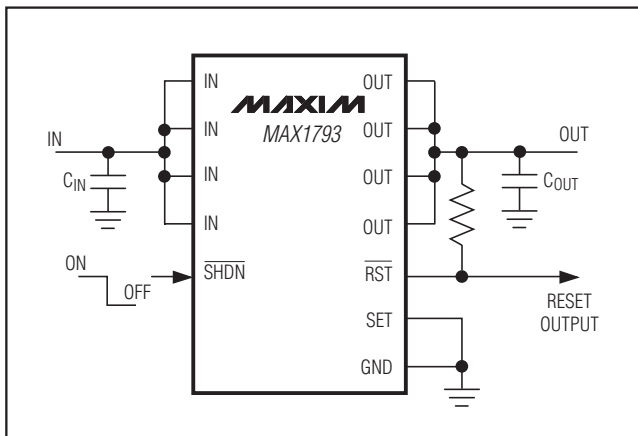

Features

- ◆ **Guaranteed 1A Output Current**
- ◆ **Low 210mV Dropout at 1A**
- ◆ **Up to $\pm 1\%$ Output Voltage Accuracy**
Preset at 1.5V, 1.8V, 2.0V, 2.5V, 3.3V or 5.0V
Adjustable from 1.25V to 5.0V
- ◆ **Reset Output (4ms Delay)**
- ◆ **Low 125 μ A Ground Current**
- ◆ **0.1 μ A Shutdown**
- ◆ **Low 115 μ V_{RMS} Output Noise**
- ◆ **Thermal-Overload Protection**
- ◆ **Output Current Limit**
- ◆ **Tiny TSSOP Power Package (1.5W)**
30% Smaller than SOT223 (only 1.1mm high)

Ordering Information

PART	TEMP RANGE	PIN-PACKAGE	V _{OUT} [†] (V)
MAX1793EUE-50	-40°C to +85°C	16 TSSOP-EP*	5.0 or Adj
MAX1793EUE-33	-40°C to +85°C	16 TSSOP-EP*	3.3 or Adj
MAX1793EUE-33/V	-40°C to +85°C	16 TSSOP-EP*	3.3 or Adj

Ordering Information continued at end of data sheet

*EP = Exposed pad.

[†]Contact factory for other preset output voltages.

/V Denotes an automotive qualified part.

Note: Devices are also available in a lead(Pb)-free/RoHS-compliant package. Specify lead-free by adding "+" to the part number when ordering.

Pin Configuration

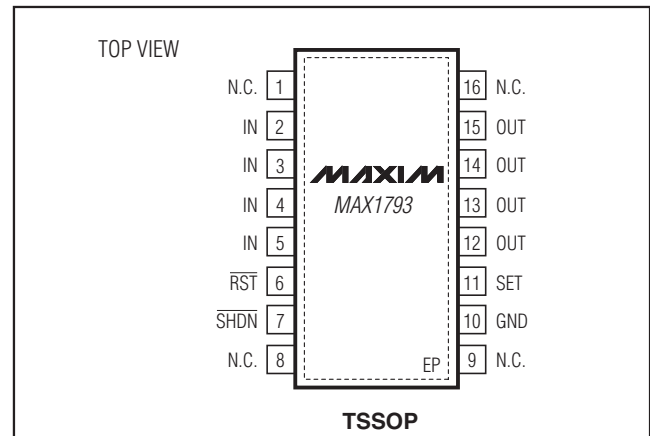

Low-Dropout, Low IQ, 1A Linear Regulator

ABSOLUTE MAXIMUM RATINGS

IN, SHDN, $\overline{\text{RST}}$ to GND-0.3V to +6V
 OUT, SET to GND-0.3V to ($V_{\text{IN}} + 0.3\text{V}$)
 Output Short-Circuit DurationInfinite
 Continuous Power Dissipation ($T_{\text{A}} = +70^{\circ}\text{C}$)
 TSSOP-EP (derate 19mW/ $^{\circ}\text{C}$ above +70 $^{\circ}\text{C}$)1.5W
 Operating Temperature Range-40 $^{\circ}\text{C}$ to +85 $^{\circ}\text{C}$
 Junction Temperature+150 $^{\circ}\text{C}$

Storage Temperature Range-65 $^{\circ}\text{C}$ to +150 $^{\circ}\text{C}$
 Lead Temperature (soldering, 10s)+300 $^{\circ}\text{C}$
 Soldering Temperature (reflow)+260 $^{\circ}\text{C}$
 Soldering Temperature (reflow)
 Lead(Pb)-Free Packages+260 $^{\circ}\text{C}$
 Packages Containing Lead(Pb)+240 $^{\circ}\text{C}$

Stresses beyond those listed under "Absolute Maximum Ratings" may cause permanent damage to the device. These are stress ratings only, and functional operation of the device at these or any other conditions beyond those indicated in the operational sections of the specifications is not implied. Exposure to absolute maximum rating conditions for extended periods may affect device reliability.

ELECTRICAL CHARACTERISTICS

($V_{\text{IN}} = V_{\text{OUT(NOM)}} + 0.5\text{V}$ or $V_{\text{IN}} = 2.5\text{V}$ (whichever is greater), $\overline{\text{SHDN}} = \text{IN}$, $T_{\text{A}} = +0^{\circ}\text{C}$ to +85 $^{\circ}\text{C}$, unless otherwise noted. Typical values are at $T_{\text{A}} = +25^{\circ}\text{C}$.)

PARAMETER	SYMBOL	CONDITIONS	MIN	TYP	MAX	UNITS	
Input Voltage	V_{IN}		2.5		5.5	V	
Input Undervoltage Lockout	V_{IN}		2.0		2.3	V	
Output Voltage Accuracy (Preset Mode, SET = GND)		$T_{\text{A}} = +85^{\circ}\text{C}$, $I_{\text{OUT}} = 250\text{mA}$	Preset $V_{\text{OUT}} \geq 2.5\text{V}$		-1	+1	%
			Preset $V_{\text{OUT}} < 2.5\text{V}$		-1.5	+1.5	
		$T_{\text{A}} = 0^{\circ}\text{C}$ to +85 $^{\circ}\text{C}$, $I_{\text{OUT}} = 250\text{mA}$			-2	+2	
		$T_{\text{A}} = 0^{\circ}\text{C}$ to +85 $^{\circ}\text{C}$, $I_{\text{OUT}} = 1\text{mA}$ to 1A, $V_{\text{IN}} > V_{\text{OUT}} + 0.5\text{V}$			-3	+3	
SET Voltage Threshold (For Adjustable Output)		$T_{\text{A}} = +85^{\circ}\text{C}$, $I_{\text{OUT}} = 250\text{mA}$, $V_{\text{IN}} = 3\text{V}$	1.229	1.250	1.271	V	
		$T_{\text{A}} = 0^{\circ}\text{C}$ to +85 $^{\circ}\text{C}$, $I_{\text{OUT}} = 250\text{mA}$, $V_{\text{IN}} = 3\text{V}$	1.219		1.281		
		$T_{\text{A}} = 0^{\circ}\text{C}$ to +85 $^{\circ}\text{C}$, $I_{\text{OUT}} = 1\text{mA}$ to 1A, $V_{\text{IN}} = 3\text{V}$	1.212		1.288		
Adjustable Output Voltage Range			1.25		5	V	
Maximum Output Current	I_{OUT}	Continuous, $V_{\text{IN}} \geq 3\text{V}$	1			A _{RMS}	
Short-Circuit Current Limit	I_{LIM}	$V_{\text{OUT}} = 0\text{V}$, $V_{\text{IN}} \geq 3\text{V}$	1.1	1.8	3.3	A	
In-Regulation Current Limit		V_{OUT} within 4% of nominal output voltage, $V_{\text{IN}} = 5.5\text{V}$		2.8		A	
SET Pin Dual Mode Threshold			50		150	mV	
SET Input Bias Current	I_{SET}	$V_{\text{SET}} = +1.25\text{V}$			± 100	nA	
Ground Current	I_{GND}	$I_{\text{OUT}} = 100\mu\text{A}$		125	200	μA	
Dropout Voltage (Note 1)	$V_{\text{IN}} - V_{\text{OUT}}$	$I_{\text{OUT}} = 1\text{A}$, SET = GND	MAX1793-33, -50	210	350	mV	
			MAX1793-25	270	450		
Line Regulation	ΔV_{LNR}	V_{IN} from ($V_{\text{OUT}} + 0.1\text{V}$) to +5.5V, $I_{\text{OUT}} = 5\text{mA}$, SET = GND	-0.15	0	+0.15	%/V	
Load Regulation	ΔV_{LDR}	$I_{\text{OUT}} = 100\mu\text{A}$ to 1A		0.7		%	
Output Voltage Noise		10Hz to 1MHz, $C_{\text{OUT}} = 6.8\mu\text{F}$ (ESR < 0.1 Ω)		115		μVRMS	
Shutdown Supply Current	I_{OFF}	$\overline{\text{SHDN}} = \text{GND}$, $V_{\text{IN}} = +5.5\text{V}$		0.1	16	μA	
Output Pulldown Resistance in Shutdown		$\overline{\text{SHDN}} = \text{GND}$		5		k Ω	

Low-Dropout, Low IQ, 1A Linear Regulator

MAX1793

ELECTRICAL CHARACTERISTICS (continued)

($V_{IN} = V_{OUT(NOM)} + 0.5V$ or $V_{IN} = 2.5V$ (whichever is greater), $\overline{SHDN} = IN$, $T_A = +0^{\circ}C$ to $+85^{\circ}C$, unless otherwise noted. Typical values are at $T_A = +25^{\circ}C$.)

PARAMETER	SYMBOL	CONDITIONS	MIN	TYP	MAX	UNITS
\overline{SHDN} Input Threshold	V_{IH}	$+2.5V < V_{IN} < +5.5V$	1.6		0.6	V
	V_{IL}					
\overline{SHDN} Input Bias Current	$I_{\overline{SHDN}}$	$\overline{SHDN} = GND$ or IN	0.01		1	μA
\overline{RST} Output Low Voltage	V_{OL}	$I_{SINK} = 1mA$			0.1	V
Operating Voltage Range for \overline{RST} Valid		$I_{SINK} = 100\mu A$	1.0	5.5		V
\overline{RST} Output High Leakage		$V_{\overline{RST}} = +5.5V$	0.01		1	μA
\overline{RST} Trip Level Referred to Nominal V_{OUT}		Rising edge	90	94	96	% V_{OUT}
\overline{RST} Release Delay		Rising edge	1.5	4.0	8.0	ms
Thermal Shutdown Temperature	$T_{\overline{SHDN}}$	Typical thermal hysteresis = $20^{\circ}C$	170			$^{\circ}C$

ELECTRICAL CHARACTERISTICS

($V_{IN} = V_{OUT(NOM)} + 0.5V$ or $V_{IN} = 2.5V$ (whichever is greater), $\overline{SHDN} = IN$, $T_A = -40^{\circ}C$ to $+85^{\circ}C$, unless otherwise noted.) (Note 2)

PARAMETER	SYMBOL	CONDITIONS	MIN	TYP	MAX	UNITS
Input Voltage	V_{IN}		2.5	5.5		V
Input Undervoltage Lockout	V_{IN}		2.0	2.3		V
Output Voltage Accuracy (preset mode, $SET = GND$)		$I_{OUT} = 250mA$	-2.5	2.5		%
		$I_{OUT} = 1mA$ to $1A$, $V_{IN} > V_{OUT} + 0.5V$	-3.2	3.2		
SET Voltage Threshold (for adjustable output)		$I_{OUT} = 250mA$, $V_{IN} = 3V$	1.216		1.284	V
		$I_{OUT} = 1mA$ to $1A$, $V_{IN} = 3V$	1.210		1.290	
Adjustable Output Voltage Range			1.25	5		V
Maximum Output Current	I_{OUT}	Continuous, $V_{IN} \geq 3V$	1			ARMS
Short-Circuit Current Limit	I_{LIM}	$V_{OUT} = 0V$, $V_{IN} \geq 3V$	1.1		3.3	A
SET Pin Dual Mode Threshold			50		150	mV
SET Input Bias Current	I_{SET}	$V_{SET} = +1.25V$			± 100	nA
Ground Current	I_{GND}	$I_{OUT} = 100\mu A$			200	μA
Dropout Voltage (Note 1)	$V_{IN} - V_{OUT}$	$I_{OUT} = 1A$, $SET = GND$	MAX1793-33, -50		350	mV
			MAX1793-25		450	
Line Regulation	ΔV_{LNR}	V_{IN} from $(V_{OUT} + 0.1V)$ to $+5.5V$, $I_{OUT} = 5mA$, $SET = GND$	-0.15		0.15	%/V
Shutdown Supply Current	I_{OFF}	$\overline{SHDN} = GND$, $V_{IN} = +5.5V$			16	μA
\overline{SHDN} Input Threshold	V_{IH}	$+2.5V < V_{IN} < +5.5V$	1.6		0.6	V
	V_{IL}					
\overline{SHDN} Input Bias Current	$I_{\overline{SHDN}}$	$\overline{SHDN} = GND$ or IN			1	μA
\overline{RST} Output Low Voltage	V_{OL}	$I_{SINK} = 1mA$			0.1	V

Low-Dropout, Low IQ, 1A Linear Regulator

ELECTRICAL CHARACTERISTICS (continued)

($V_{IN} = V_{OUT(NOM)} + 0.5V$ or $V_{IN} = 2.5V$ (whichever is greater), $\overline{SHDN} = IN$, $T_A = -40^{\circ}C$ to $+85^{\circ}C$, unless otherwise noted.) (Note 2)

PARAMETER	SYMBOL	CONDITIONS	MIN	TYP	MAX	UNITS
Operating Voltage Range for \overline{RST} Valid		$I_{SINK} = 10\mu A$	1.0		5.5	V
\overline{RST} Output High Leakage		$V_{\overline{RST}} = +5.5V$			1	μA
\overline{RST} Trip Level Referred to Nominal V_{OUT}		Rising edge	90		96	% V_{OUT}
\overline{RST} Release Delay		Rising edge	1.5		8.0	ms

Note 1: Dropout voltage is defined as $V_{IN} - V_{OUT}$, when V_{OUT} is 100mV below the value of V_{OUT} measured when $V_{IN} = V_{OUT(NOM)} + 0.5V$. Since the minimum input voltage is 2.5V, this specification is only meaningful when $V_{OUT(NOM)} \geq 2.5V$. For $V_{OUT(NOM)}$ between 2.5V and 3.3V, use the following equations: Typical Dropout = $210mV + (3.3V - V_{OUT(NOM)}) \times 75mV/V$; Guaranteed Maximum Dropout = $350mV + (3.3V - V_{OUT(NOM)}) \times 125mV/V$. For $V_{OUT(NOM)} > 3.3V$: Typical Dropout = 210mV; Guaranteed Maximum Dropout = 350mV.

Note 2: Specifications to $T_A = -40^{\circ}C$ are guaranteed by design and not production tested.

Typical Operating Characteristics

(Circuit of Figure 2, $V_{IN} = +5V$, $V_{\overline{SHDN}} = V_{IN}$, $V_{OUT} = +3.3V$, $T_A = +25^{\circ}C$, unless otherwise noted.)

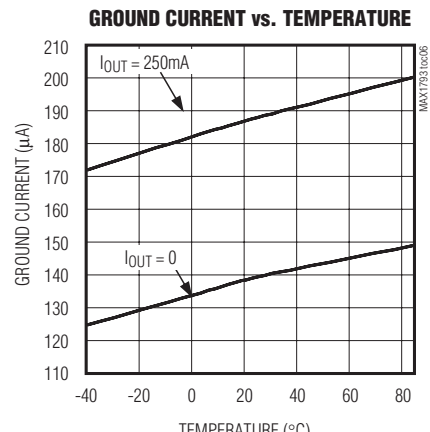
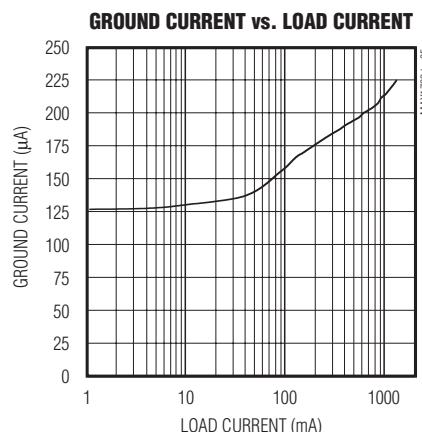
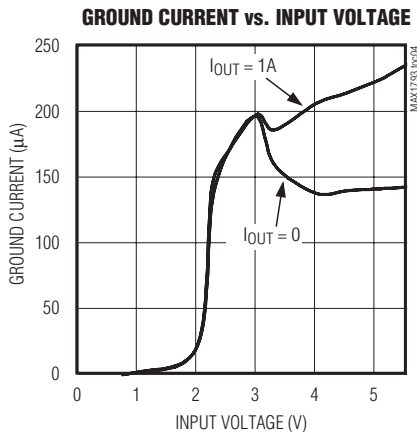
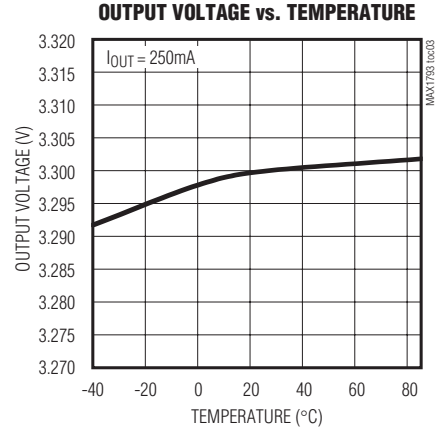
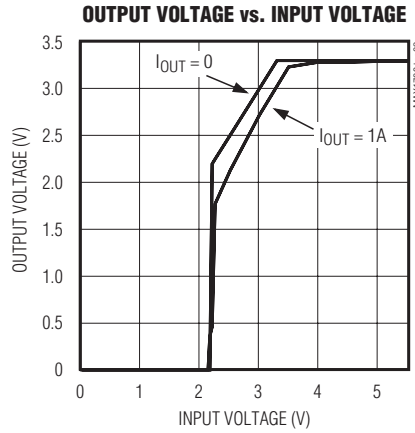
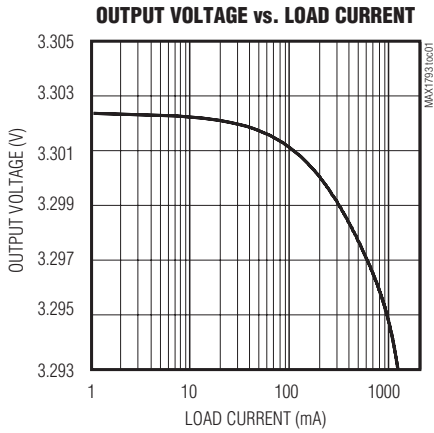

Low-Dropout, Low IQ, 1A Linear Regulator

MAX1793

Typical Operating Characteristics (continued)

(Circuit of Figure 2, $V_{IN} = +5V$, $V_{SHDN} = V_{IN}$, $V_{OUT} = +3.3V$, $T_A = +25^\circ C$, unless otherwise noted.)

DROPOUT VOLTAGE vs. LOAD CURRENT

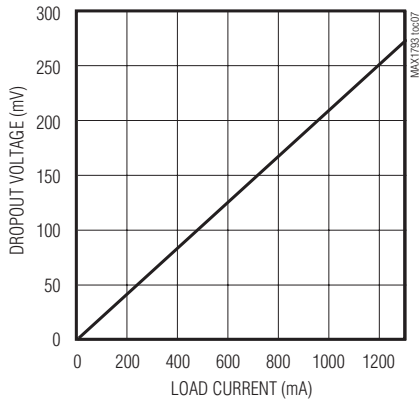

POWER-SUPPLY REJECTION RATIO vs. FREQUENCY

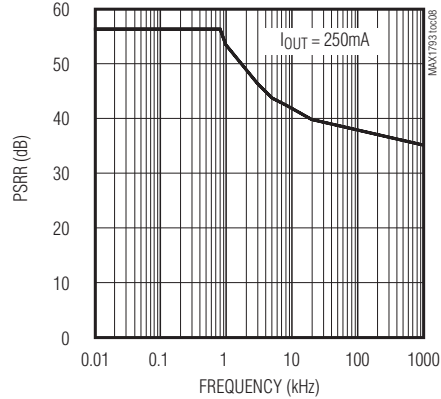

OUTPUT NOISE SPECTRAL DENSITY vs. FREQUENCY

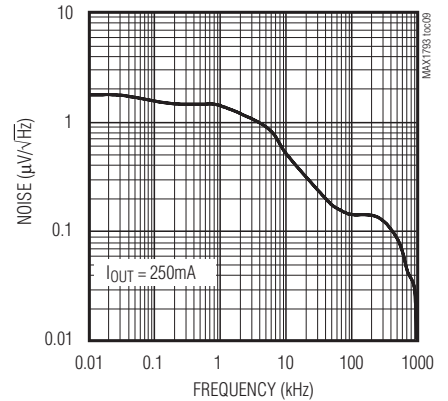

OUTPUT NOISE vs. LOAD CURRENT

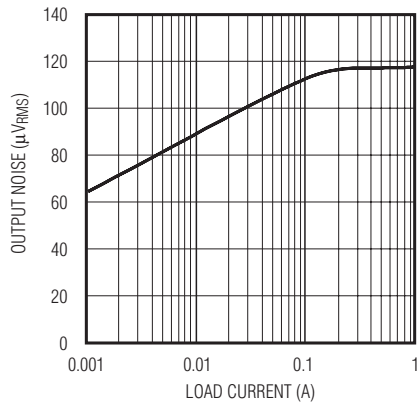

LINE-TRANSIENT RESPONSE

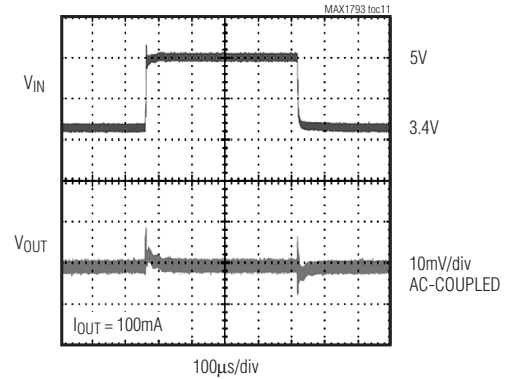

LOAD-TRANSIENT RESPONSE

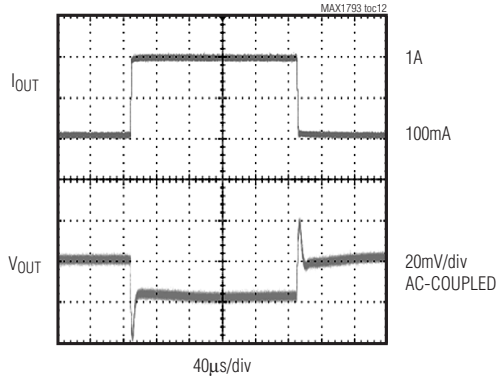

OUTPUT NOISE

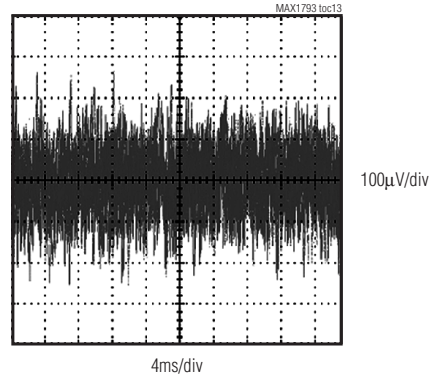

Low-Dropout, Low IQ, 1A Linear Regulator

Typical Operating Characteristics (continued)

(Circuit of Figure 2, $V_{IN} = +5V$, $\overline{V_{SHDN}} = V_{IN}$, $V_{OUT} = +3.3V$, $T_A = +25^\circ C$, unless otherwise noted.)

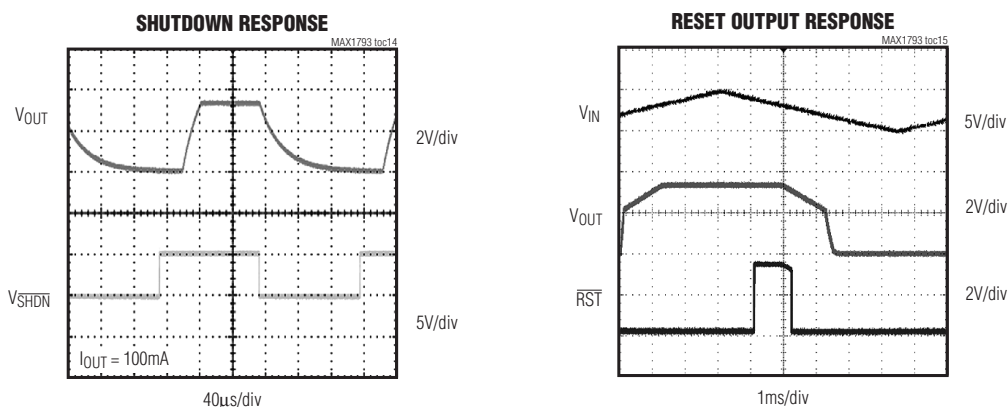

Pin Description

PIN	NAME	FUNCTION
1, 8, 9, 16	N.C.	No Connection. Not internally connected.
2-5	IN	Regulator Input. Supply voltage ranges from +2.5V to +5.5V. Bypass with a 4.7 μ F capacitor to GND (see the <i>Capacitor Selection and Regulator Stability</i>). These inputs are internally connected, but they also must be externally connected for proper operation.
6	\overline{RST}	Reset Output. Open-drain output is low when V_{OUT} is 6% below its nominal value. \overline{RST} remains low while the output voltage (V_{OUT}) is below the reset threshold and for at least 4ms after V_{OUT} rises above the reset threshold. Connect a 100k Ω pullup resistor to OUT to obtain an output voltage.
7	\overline{SHDN}	Active-Low Shutdown Input. A logic-low disables the output and reduces the supply current to 0.1 μ A. In shutdown, the \overline{RST} output is low and OUT is pulled low through an internal 5k Ω resistance. Connect \overline{SHDN} to IN for normal operation.
10	GND	Ground. This pin and the exposed pad also function as a heatsink. Solder both to a large pad or to the circuit-board ground plane to maximize power dissipation.
11	SET	Voltage-Setting Input. Connect to GND to select the factory-present output voltage. Connect SET to an external resistor-divider for adjustable-output operation.
12-15	OUT	Regulator Output. Bypass with a 6.8 μ F, low-ESR capacitor to GND. Connect all OUT pins together at the IC.
—	EP	Exposed Pad. Connect to the ground plane. EP also functions as a heatsink. Solder to the circuit-board ground plane to maximize thermal dissipation.

Low-Dropout, Low IQ, 1A Linear Regulator

MAX1793

Detailed Description

The MAX1793 features Dual Mode™ operation, allowing a fixed output or an adjustable output from +1.25V to +5V. The regulators are guaranteed to supply 1A of output current.

As Figure 1 shows, the device consists of a +1.25V reference, error amplifier, MOSFET driver, p-channel pass transistor, internal feedback voltage-divider, Dual Mode comparator, and 4ms reset output.

The +1.25V reference is connected to the inverting input of the error amplifier. The error amplifier compares this reference with the selected feedback voltage and amplifies the difference. The MOSFET driver reads the error signal and applies the appropriate drive to the p-channel transistor. If the feedback voltage is lower than the reference, the pass transistor's gate is pulled

lower, allowing more current to pass and increase the output voltage. If the feedback voltage is high, the pass transistor's gate is pulled up, allowing less current to pass to the output. The low V_{OUT} comparator senses when the feedback voltage has dropped 6% below its expected level, causing RST to go low.

The output voltage is fed back through either an internal resistor-divider connected to OUT or an external resistor network connected to SET. The Dual Mode comparator examines V_{SET} and selects the feedback path. If V_{SET} is below 50mV, the internal feedback path is used and the output is regulated to the factory-preset voltage.

Dual Mode is a trademark of Maxim Integrated Products, Inc.

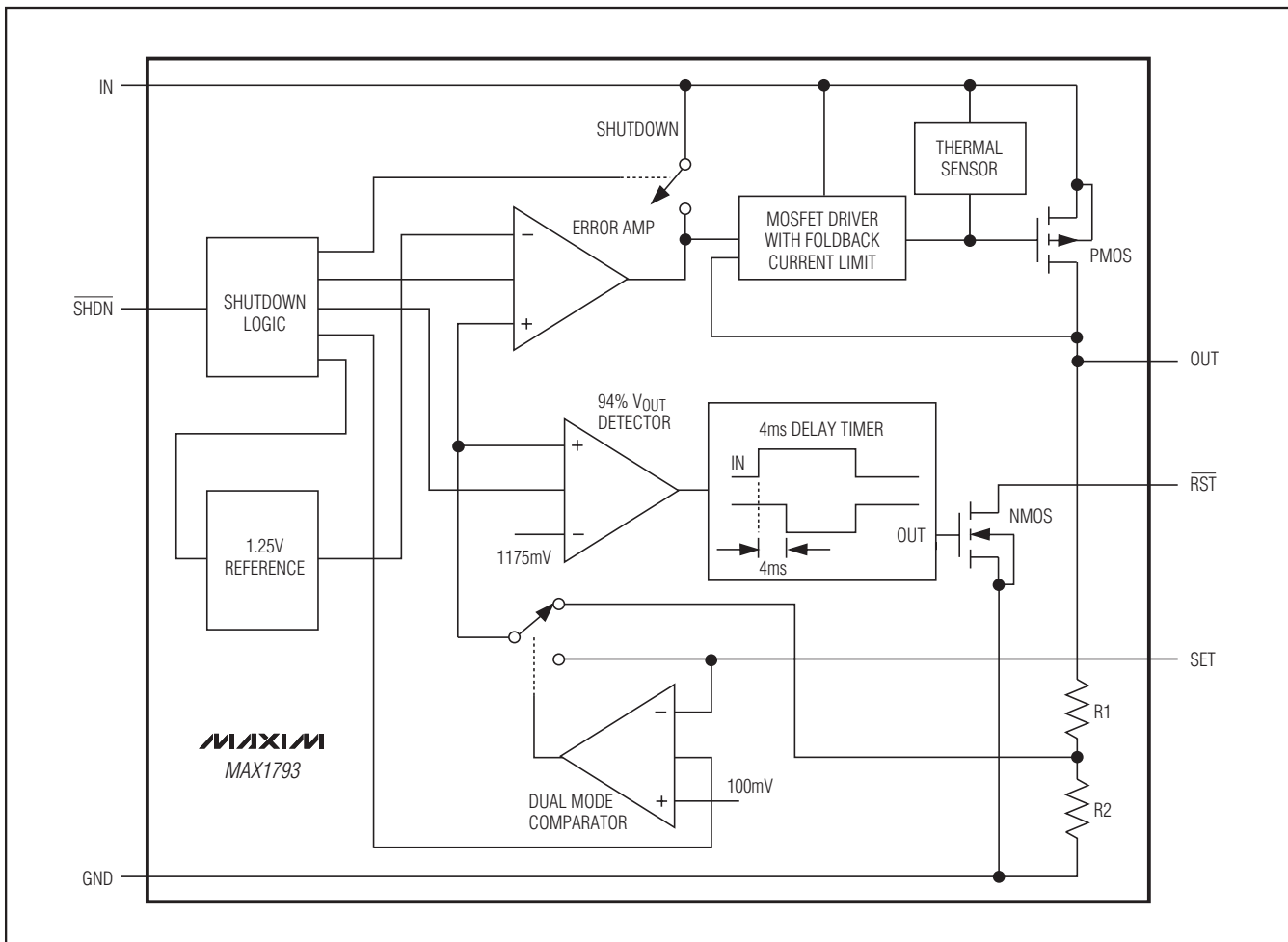

Figure 1. Functional Diagram

Low-Dropout, Low I_Q, 1A Linear Regulator

Internal p-Channel Pass Transistor

The MAX1793 features a 1A p-channel MOSFET pass transistor. Unlike similar designs using pnp pass transistors, p-channel MOSFETs require no base drive, which reduces quiescent current. pnp-based regulators also waste considerable current in dropout when the pass transistor saturates and use high base-drive currents under large loads. The MAX1793 does not suffer from these problems and consumes only 225μA of quiescent current under heavy loads, as well as in dropout.

Output Voltage Selection

The MAX1793 features Dual Mode operation. In preset voltage mode, the output of the MAX1793 is set to an internally trimmed voltage (see the *Ordering Information*). Select this mode by connecting SET to GND (Figure 2).

In adjustable mode, an output is selected between +1.25V and +5V using two external resistors connected as a voltage-divider to SET (Figure 3). The output voltage is determined by the following equation:

$$V_{OUT} = V_{SET} [1 + (R1/R2)]$$

where $V_{SET} = +1.25V$. To simplify resistor selection:

$$R1 = R2 [(V_{OUT}/V_{SET}) - 1]$$

Since the input bias current at SET is less than 100nA, large resistance values can be used for R1 and R2 to minimize power consumption without losing efficiency. Up to 125kΩ is acceptable for R2.

In preset voltage mode, the impedance from SET to GND should be less than 10kΩ. Otherwise, spurious conditions could cause the voltage at SET to exceed the 50mV dual-mode threshold.

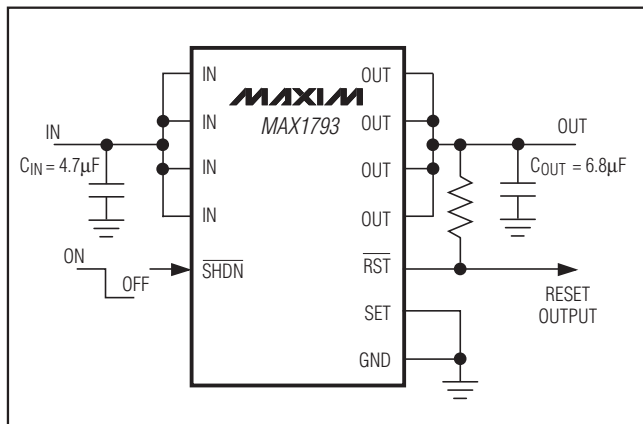

Figure 2. Typical Operating Circuit with Preset Output Voltage

Shutdown

A logic-low on \overline{SHDN} disables the MAX1793. In shutdown, the pass transistor, control circuitry, reference, and all internal circuits are turned off, reducing supply current to typically 0.1μA. Connect \overline{SHDN} to IN for normal operation. In shutdown, \overline{RST} goes low and OUT is discharged to GND with a 5kΩ internal resistance.

\overline{RST} Comparator

The MAX1793 features a low V_{OUT} indicator that asserts when the output voltage falls out of regulation. The open-drain \overline{RST} output goes low when OUT falls 6% below its nominal output voltage. \overline{RST} remains low for 4ms after OUT has returned to its nominal value. A 100kΩ pullup resistor from \overline{RST} to a suitable logic supply voltage (typically OUT) provides a logic control signal. \overline{RST} can be used as a power-on-reset (POR) signal to a microcontroller or can drive an external LED to indicate power failure. \overline{RST} is low during shutdown.

Current Limiting

The MAX1793 features a current limit that monitors the pass transistor, typically limiting short-circuit output current to 1.8A. The current limit is increased to approximately 2.8A when the output voltage is in regulation, improving performance with large transient loads. The output can be shorted to ground for an indefinite period of time without damaging the device.

Thermal-Overload Protection

Thermal-overload protection limits total power dissipation in the MAX1793. When the junction temperature exceeds $T_J = +170^\circ C$, a thermal sensor turns off the pass transistor, allowing the IC to cool. The thermal sensor turns the pass transistor on once the IC's junction temperature drops approximately $20^\circ C$. Continuous short-circuit conditions will result in a pulsed output.

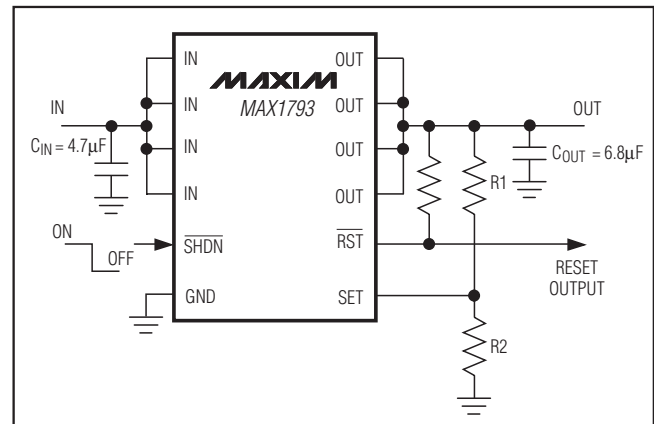

Figure 3. Typical Operating Circuit with Adjustable Output Voltage

Low-Dropout, Low IQ, 1A Linear Regulator

Thermal-overload protection is designed to safeguard the MAX1793 in the event of fault conditions. For continuous operation, do not exceed the absolute maximum junction-temperature rating of $T_J = +150^\circ\text{C}$.

Operating Region and Power Dissipation

Maximum power dissipation of the MAX1793 depends on the thermal resistance of the case and circuit board, the temperature difference between the die junction and ambient air, and the rate of air flow. The power dissipated by the device is: $P = I_{OUT} (V_{IN} - V_{OUT})$. The resulting maximum power dissipation is:

$$P_{MAX} = [(T_{J(MAX)} - T_A)/(\theta_{JC} + \theta_{CA})]$$

where $(T_{J(MAX)} - T_A)$ is the temperature difference between the maximum allowed die junction ($+150^\circ\text{C}$) and the surrounding air, θ_{JC} (junction-to-case) is the thermal resistance of the package chosen, and θ_{CA} is the thermal resistance from the case through the PCB, copper traces, and other materials to the surrounding air. Figure 4 shows allowable power dissipation for typical PCBs at $+25^\circ\text{C}$, $+50^\circ\text{C}$, and $+70^\circ\text{C}$ ambient temperatures.

The MAX1793 TSSOP-EP package features an exposed thermal pad on its underside. This pad lowers the thermal resistance of the package by providing a direct heat conduction path from the die to the PCB. Additionally, the ground pin (GND) also channels heat. Connect the exposed thermal pad and GND to circuit ground by using a large pad (minimum 1in^2 recommended), or multiple vias to the ground plane.

Applications Information

Capacitor Selection and Regulator Stability

Capacitors are required at the input and output of the MAX1793. Connect a $4.7\mu\text{F}$ capacitor between IN and ground (C_{IN}) and a $6.8\mu\text{F}$ capacitor between OUT and ground (C_{OUT}). C_{IN} serves only to lower the source impedance of the input supply and may be smaller than $4.7\mu\text{F}$ when the MAX1793 is powered from regulated power supplies or low-impedance batteries.

The output capacitor's equivalent series resistance (ESR) affects stability and output noise. C_{OUT} ESR should be 0.5Ω or less to ensure stability and optimum transient response. Surface-mount ceramic capacitors have very low ESR and are commonly available in values up to $10\mu\text{F}$. Other low-ESR ($< 0.5\Omega$) capacitors, such as surface-mount tantalum or OS-CON, may also be used. Connect C_{IN} and C_{OUT} as close to the IC as possible to minimize the impact of PCB trace inductance.

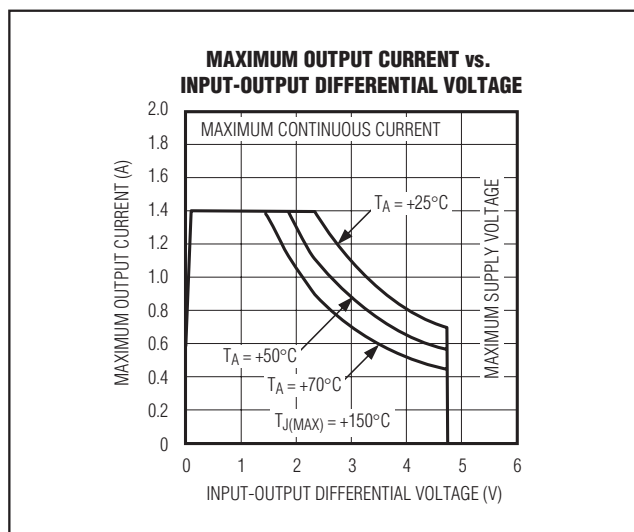

Figure 4. Power Operating Region: Maximum Output Current vs. Input-Output Differential Voltage

Noise, PSRR, and Transient Response

The MAX1793 output noise is typically $115\mu\text{VRMS}$ during normal operation. This is suitably low for most applications. See the output noise plot in the *Typical Operating Characteristics*.

The MAX1793 is designed to achieve low dropout voltage and low quiescent current in battery-powered systems while still maintaining good noise, transient response, and AC rejection. See the *Typical Operating Characteristics* for a plot of Power-Supply Rejection Ratio (PSRR) vs. Frequency. When operating from very noisy sources, supply noise rejection and transient response can be improved by increasing the values of the input and output capacitors and employing passive postfiltering.

Input-Output (Dropout) Voltage

A regulator's minimum input-to-output voltage differential (dropout voltage) determines the lowest usable supply voltage. In battery-powered systems, this determines the useful end-of-life battery voltage. Since a p-channel MOSFET is used as the pass device, dropout voltage is the product of $R_{DS(ON)}$ and load current (see the *Electrical Characteristics* and Dropout Voltage vs. Load Current in the *Typical Operating Characteristics*). The MAX1793 operating current typically remains below $225\mu\text{A}$ in dropout.

Low-Dropout, Low IQ, 1A Linear Regulator

Ordering Information (continued)

PART	TEMP RANGE	PIN-PACKAGE	V _{out} [†] (V)
MAX1793EUE-25	-40°C to +85°C	16 TSSOP-EP*	2.5 or Adj
MAX1793EUE-20	-40°C to +85°C	16 TSSOP-EP*	2.0 or Adj
MAX1793EUE-18	-40°C to +85°C	16 TSSOP-EP*	1.8 or Adj
MAX1793EUE-15	-40°C to +85°C	16 TSSOP-EP*	1.5 or Adj

*EP = Exposed pad.

[†]Contact factory for other preset output voltages.

/V Denotes an automotive qualified part.

Note: Devices are also available in a lead(Pb)-free/RoHS-compliant package. Specify lead-free by adding "+" to the part number when ordering.

Package Information

For the latest package outline information and land patterns (footprints), go to www.maxim-ic.com/packages. Note that a "+", "#", or "-" in the package code indicates RoHS status only. Package drawings may show a different suffix character, but the drawing pertains to the package regardless of RoHS status.

PACKAGE TYPE	PACKAGE CODE	OUTLINE NO.	LAND PATTERN NO.
16 TSSOP-EP	U16E-3	21-0108	90-0120

Low-Dropout, Low IQ, 1A Linear Regulator

Revision History

REVISION NUMBER	REVISION DATE	DESCRIPTION	PAGES CHANGED
0	8/00	Initial release	—
1	11/00	Added output voltages and updated <i>Electrical Characteristics</i> .	1-4, 7-9
2	9/09	Added the automotive version of the MAX1793.	1
3	1/12	Added lead-free options and updated soldering temperature and <i>Pin Description</i>	1, 2, 6, 10

MAX1793

Maxim cannot assume responsibility for use of any circuitry other than circuitry entirely embodied in a Maxim product. No circuit patent licenses are implied. Maxim reserves the right to change the circuitry and specifications without notice at any time. The parametric values (min and max limits) shown in the Electrical Characteristics table are guaranteed. Other parametric values quoted in this data sheet are provided for guidance.

11 _____ **Maxim Integrated Products, 120 San Gabriel Drive, Sunnyvale, CA 94086 408-737-7600**

Looking for pricing, stock, or lifecycle information?

Click below to explore more details on WIN SOURCE:

- ⊖ [View MAX1793EUE50+](#) on WIN SOURCE
- ⊖ [Maxim Integrated](#) Information

Optimize Your Supply Chain with WIN SOURCE Solutions

- ✓ Global Sourcing Solution
- ✓ Obsolete Management
- ✓ Cost Control Management
- ✓ Shortage Management
- ✓ Alternative Solution
- ✓ Excess Inventory Management