



**THE DATASHEET OF  
MAX16836ASA+T**



# High-Voltage, 350mA, High-Brightness LED Driver with PWM Dimming and 5V Regulator

## General Description

The MAX16836 current regulator operates from a 6.5V to 40V input-voltage range and delivers up to a total of 350mA to one or more strings of high-brightness LEDs (HB LEDs). The output current of the MAX16836 is adjusted by using an external current-sense resistor in series with the LEDs. A dimming input allows wide-range "pulsed" PWM operation. Wave-shaping circuitry reduces EMI. The differential current-sense input increases noise immunity. The MAX16836 is well suited for applications requiring a high-voltage input and is able to withstand automotive load-dump events up to 40V. An on-board pass element minimizes external components while providing  $\pm 3.5\%$  output-current accuracy. Additional features include a 5V regulated output and short-circuit and thermal protection.

The MAX16836 is available in a thermally enhanced, 5mm x 5mm, 16-pin TQFN package and in an 8-pin SO package with exposed pad. The MAX16836 is specified over the automotive  $-40^{\circ}\text{C}$  to  $+125^{\circ}\text{C}$  temperature range.

## Applications

Automotive Interior: Map, Courtesy, and Cluster Lighting

Automotive Exterior: Tail Lights and CHMSL

Emergency Vehicle Warning Lights

Navigation and Marine Indicators

General Lighting

Signage, Gasoline Canopies, Beacons

## Typical Operating Circuit

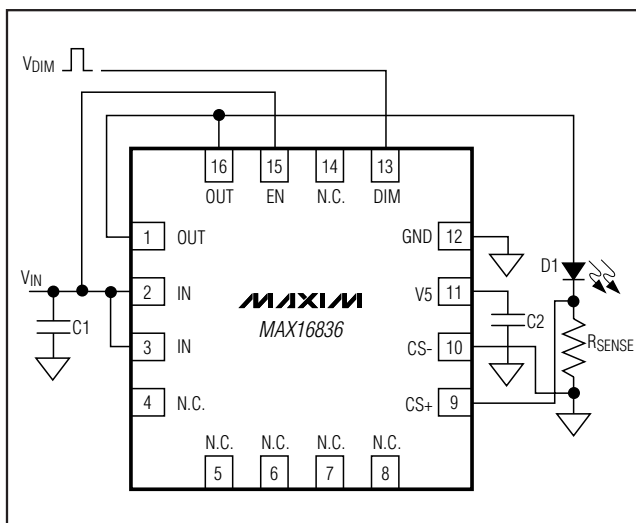

## Features

- ◆ +6.5V to +40V Operating Range
- ◆ Adjustable LED Current (35mA to 350mA)
- ◆  $\pm 3.5\%$  LED Current Accuracy
- ◆ High-Voltage DIM Pin for Dimming Interface
- ◆ Integrated Pass Element with Low-Dropout Voltage (0.55V typ)
- ◆ +5V Regulated Output with 4mA Source Capability
- ◆ Parallel Operation for LED Current > 350mA
- ◆ Differential LED Current Sense
- ◆ Low Shutdown Supply Current (35 $\mu\text{A}$  typ)
- ◆ Low 200mV Current-Sense Reference Reduces Power Losses
- ◆ Wave-Shaped Edges Reduce Radiated EMI During PWM Dimming
- ◆ Thermal Shutdown
- ◆ Output Short-Circuit Protection
- ◆ Available in Small, Thermally Enhanced, 5mm x 5mm, 16-Pin TQFN Package and in 8-Pin SO with Exposed Pad Package
- ◆  $-40^{\circ}\text{C}$  to  $+125^{\circ}\text{C}$  Operating Temperature Range

## Ordering Information

PART	TEMP RANGE	PIN-PACKAGE
MAX16836ATE+	$-40^{\circ}\text{C}$ to $+125^{\circ}\text{C}$	16 TQFN-EP*
MAX16836ASA+	$-40^{\circ}\text{C}$ to $+125^{\circ}\text{C}$	8 SO-EP*

+Denotes a lead(Pb)-free/RoHS-compliant package.

\*EP = Exposed pad.

## Simplified Diagram

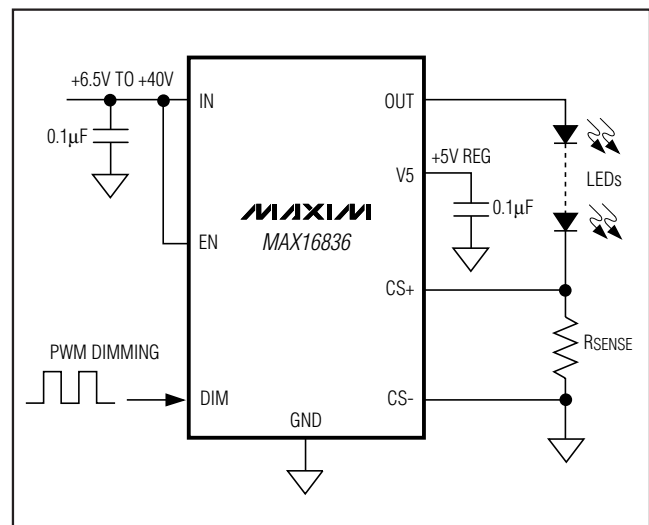

# High-Voltage, 350mA, High-Brightness LED Driver with PWM Dimming and 5V Regulator

## ABSOLUTE MAXIMUM RATINGS

IN to GND .....	-0.3V to +45V
OUT, DIM, and EN to GND .....	-0.3V to (V <sub>IN</sub> + 0.3V)
CS+, CS-, V5 to GND .....	-0.3V to +6V
OUT Short Circuited to GND Duration (at V <sub>IN</sub> = +16V) .....	60 minutes
Maximum Current into Any Pin (except IN and OUT) .....	±20mA
Continuous Power Dissipation (T <sub>A</sub> = +70°C) 16-Pin TQFN 5mm x 5mm (derate 33.3mW/°C above +70°C) .....	2666.7mW
8-Pin SO (derate 23.3mW/°C above +70°C) .....	1860.5mW

Junction-to-Case Thermal Resistance (θ <sub>JC</sub> )(Note 1) 8-Pin SO .....	7°C/W
16-Pin TQFN .....	2°C/W
Junction-to-Ambient Thermal Resistance (θ <sub>JA</sub> )(Note 1) 8-Pin SO .....	43°C/W
16-Pin TQFN .....	30°C/W
Operating Junction Temperature Range .....	-40°C to +125°C
Junction Temperature .....	+150°C
Storage Temperature Range .....	-65°C to +150°C
Lead Temperature (soldering, 10s) .....	+300°C

**Note 1:** Package thermal resistances obtained using the method described in JEDEC specification JESD51-7, using a four-layer board. For detailed information on package thermal considerations, see [www.maxim-ic.com/thermal-tutorial](http://www.maxim-ic.com/thermal-tutorial).

Stresses beyond those listed under "Absolute Maximum Ratings" may cause permanent damage to the device. These are stress ratings only, and functional operation of the device at these or any other conditions beyond those indicated in the operational sections of the specifications is not implied. Exposure to absolute maximum rating conditions for extended periods may affect device reliability.

## ELECTRICAL CHARACTERISTICS

(V<sub>IN</sub> = V<sub>EN</sub> = +12V, C<sub>V5</sub> = 0.1μF to GND, I<sub>V5</sub> = 0, V<sub>CS-</sub> = 0V, V<sub>DIM</sub> = +4V, connect R<sub>SENSE</sub> = 0.58Ω between CS+ and CS-, T<sub>A</sub> = -40°C to +125°C, unless otherwise noted. Typical values are at T<sub>A</sub> = +25°C.) (Note 2)

PARAMETER	SYMBOL	CONDITIONS	MIN	TYP	MAX	UNITS
Supply Voltage Range	V <sub>IN</sub>	(Note 3)	6.5		40.0	V
Ground Current	I <sub>G</sub>	I <sub>LOAD</sub> = 350mA		1.28	3	mA
Shutdown Supply Current	I <sub>SHDN</sub>	V <sub>EN</sub> ≤ 0.6V		35	70	μA
Guaranteed Output Current	I <sub>OUT</sub>	R <sub>SENSE</sub> = 0.55Ω	350			mA
Output Current Accuracy		35mA < I <sub>OUT</sub> < 350mA		±3.5		%
Dropout Voltage (Note 4)	ΔV <sub>DO</sub>	I <sub>OUT</sub> = 350mA (current pulsed), 12V < V <sub>IN</sub> < 40V		0.55	1.2	V
		I <sub>OUT</sub> = 350mA (current pulsed), 6.5V < V <sub>IN</sub> < 12V		0.55	1.5	
Output Current Slew Rate		Current rising, V <sub>DIM</sub> rising to 4V		7.8		mA/μs
		Current falling, V <sub>DIM</sub> falling to 0.6V		7.8		
Short-Circuit Current		V <sub>IN</sub> = 12V, V <sub>CS+</sub> = 0V	400	500	650	mA
<b>LOGIC INPUT</b>						
EN Input Current	I <sub>EN</sub>		-2.5	-1.0	-0.2	μA
EN Input Voltage High	V <sub>IH</sub>		2.8			V
EN Input Voltage Low	V <sub>IL</sub>				0.6	V
Turn-On Time	t <sub>ON</sub>	V <sub>EN</sub> rising edge to 90% of OUT		110	350	μs
<b>CURRENT SENSE</b>						
Regulated R <sub>SENSE</sub> Voltage	V <sub>SENSE</sub>	V <sub>SENSE</sub> = V <sub>CS+</sub> - V <sub>CS-</sub>	193	200	207	mV
CS- Voltage Range			-0.3		+4.1	V
Input Current (CS+)		V <sub>CS+</sub> = 220mV		2.7	7.0	μA
Input Current (CS-)		V <sub>CS+</sub> = 220mV	-50	17.2		μA
DIM Input Current			-2.5	-1.0	-0.2	μA
DIM Input Voltage High	V <sub>IH</sub>		4			V
DIM Input Voltage Low	V <sub>IL</sub>				0.6	V
Turn-On Time	t <sub>ON</sub>	After V <sub>DIM</sub> rising to 4V (Note 5)			110	μs
Turn-Off Time	t <sub>OFF</sub>	After V <sub>DIM</sub> falling to 0.6V (Note 5)			70	μs

# High-Voltage, 350mA, High-Brightness LED Driver with PWM Dimming and 5V Regulator

MAX16836

## ELECTRICAL CHARACTERISTICS (continued)

( $V_{IN} = V_{EN} = +12V$ ,  $C_{V5} = 0.1\mu F$  to GND,  $I_{V5} = 0$ ,  $V_{CS-} = 0V$ ,  $V_{DIM} = +4V$ , connect  $R_{SENSE} = 0.58\Omega$  between CS+ and CS-.  $T_A = -40^\circ C$  to  $+125^\circ C$ , unless otherwise noted. Typical values are at  $T_A = +25^\circ C$ .) (Note 2)

PARAMETER	SYMBOL	CONDITIONS	MIN	TYP	MAX	UNITS
<b>THERMAL OVERLOAD</b>						
Thermal-Shutdown Temperature				+159		$^\circ C$
Thermal-Shutdown Hysteresis				24		$^\circ C$
<b>+5V REGULATOR</b>						
Output Voltage Regulation	$V_{V5}$	(Note 6)	4.85	5.00	5.20	V
V5 Short-Circuit Current		$V_{V5} = 0V$ (Note 7)		15		mA

**Note 2:** All devices are 100% production tested at  $T_A = +25^\circ C$ . Limits over the operating temperature range are guaranteed by design.

**Note 3:** Resistors were added from OUT to CS+ to aid with the power dissipation during testing.

**Note 4:** Dropout is measured as follows:

Connect  $R_O = 27\Omega$  from OUT to CS+. Connect  $R_{SENSE} = 0.58\Omega$  from CS+ to CS-. Set  $V_{IN} = +12V$  (record  $V_{OUT}$  as  $V_{OUT1}$ ). Reduce  $V_{IN}$  until  $V_{OUT} = 0.97 \times V_{OUT1}$  (record as  $V_{IN2}$  and  $V_{OUT2}$ ).  $\Delta V_{DO} = V_{IN2} - V_{OUT2}$ .

**Note 5:**  $t_{ON}$  time includes the delay and the rise time needed for  $I_{OUT}$  to reach 90% of its final value.  $t_{OFF}$  time is the time needed for  $I_{OUT}$  to drop below 10%. See the *Typical Operating Characteristics*.  $t_{ON}$  and  $t_{OFF}$  are tested with  $13\Omega$  from OUT to CS+.

**Note 6:** Current regulation varies with V5 load (see the *Typical Operating Characteristics*).

**Note 7:** Thermal shutdown does not function if the output of the 5V reference is shorted to ground.

## Typical Operating Characteristics

( $V_{IN} = V_{EN} = +12V$ ,  $T_A = +25^\circ C$ , unless otherwise noted.)

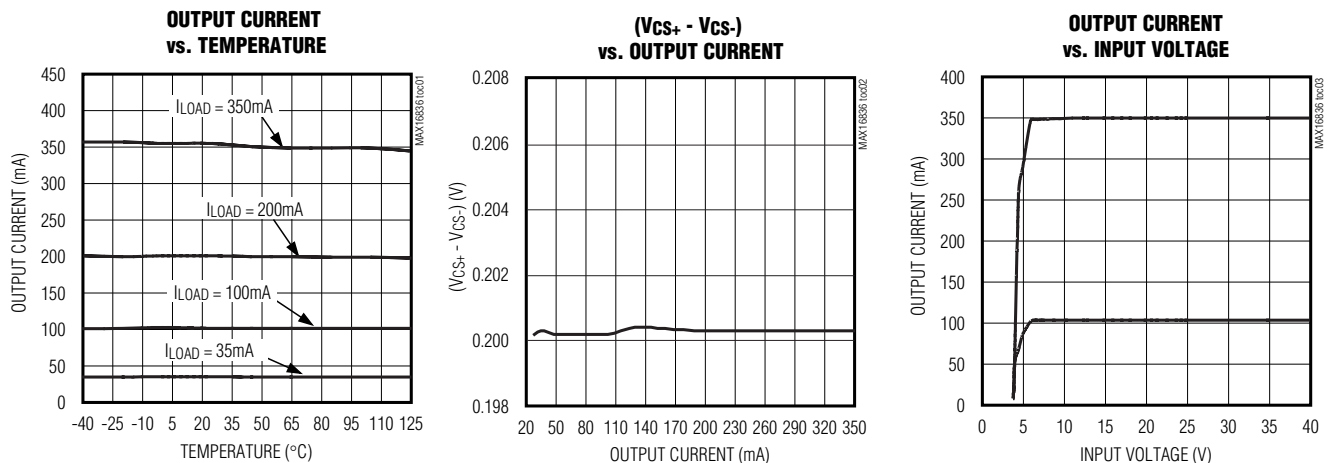

# High-Voltage, 350mA, High-Brightness LED Driver with PWM Dimming and 5V Regulator

## Typical Operating Characteristics (continued)

( $V_{IN} = V_{EN} = +12V$ ,  $T_A = +25^\circ C$ , unless otherwise noted.)

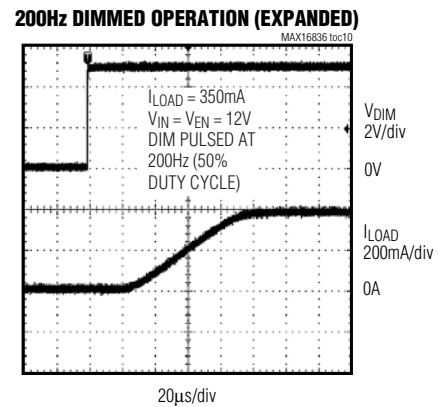
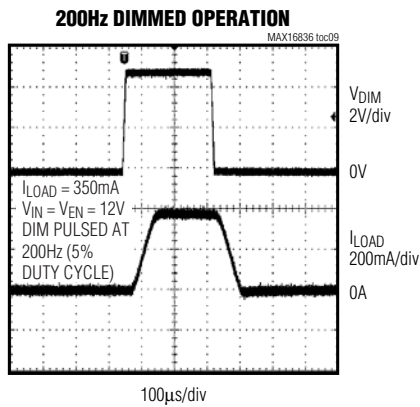
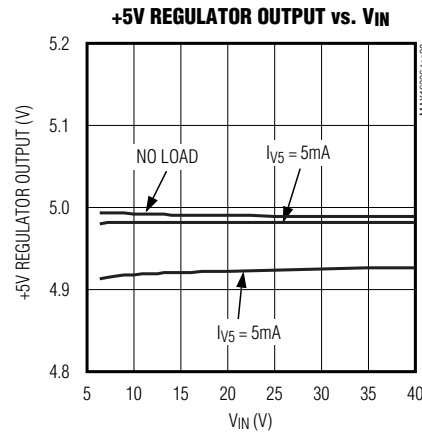
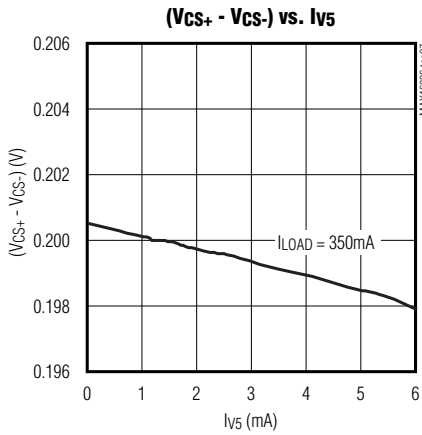
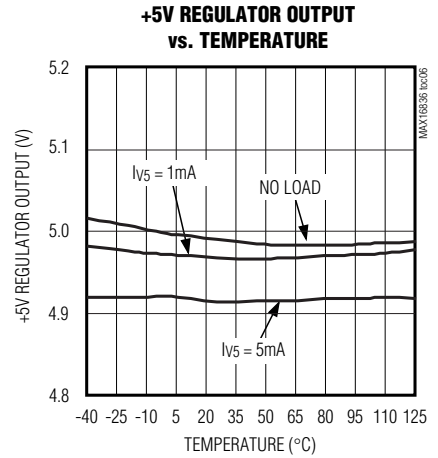
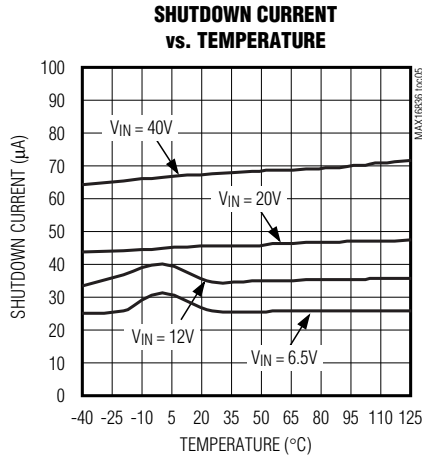
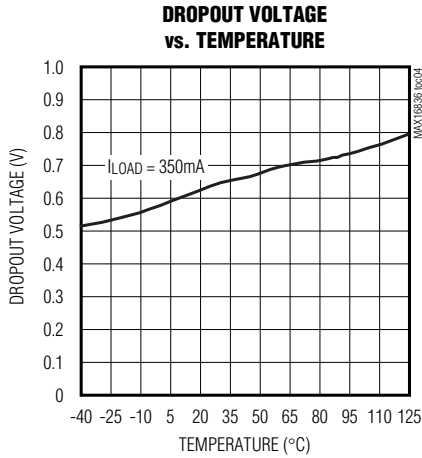

# High-Voltage, 350mA, High-Brightness LED Driver with PWM Dimming and 5V Regulator

MAX16836

## Typical Operating Characteristics (continued)

( $V_{IN} = V_{EN} = +12V$ ,  $T_A = +25^\circ C$ , unless otherwise noted.)

**200Hz DIMMED OPERATION (EXPANDED)**

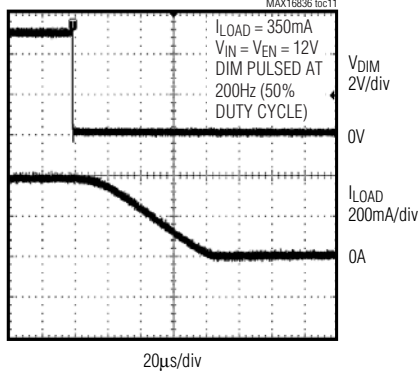

**VSENSE vs. Vcs-**

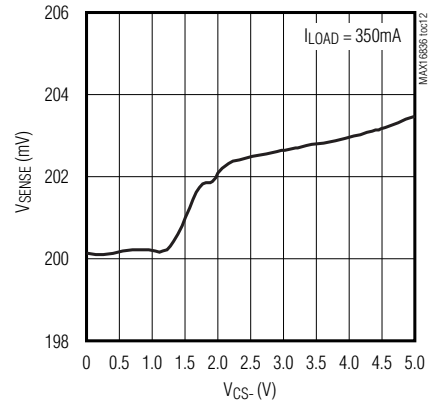

## Pin Description

PIN		NAME	FUNCTION
TQFN	SO		
1, 16	8	OUT	Current-Regulated Output. Connect pin 1 to pin 16.
2, 3	1	IN	Positive Input Supply. Bypass IN with a 0.1 $\mu F$ (min) capacitor to GND. Connect pin 2 to pin
4-8, 14	—	N.C.	No Connection. Not internally connected.
9	2	CS+	Positive Input of the Internal Differential Amplifier. Connect the current-sense resistor between CS+ and CS- to program the output current level.
10	3	CS-	Negative Input of the Internal Differential Amplifier. Connect the current-sense resistor between CS- and CS+ to program the output current level.
11	4	V5	+5V Regulated Output. Connect a 0.1 $\mu F$ capacitor from V5 to GND.
12	5	GND	Ground
13	6	DIM	Pulsed Dimming Input. Drive DIM low to disable the output. Drive DIM high or leave unconnected to enable the output.
15	7	EN	Enable Input. Drive EN high to enable the output.
—	—	EP	Exposed Pad. Connect to the ground plane for effective power dissipation. Do not use as the only ground connection.

# High-Voltage, 350mA, High-Brightness LED Driver with PWM Dimming and 5V Regulator

## Functional Diagram

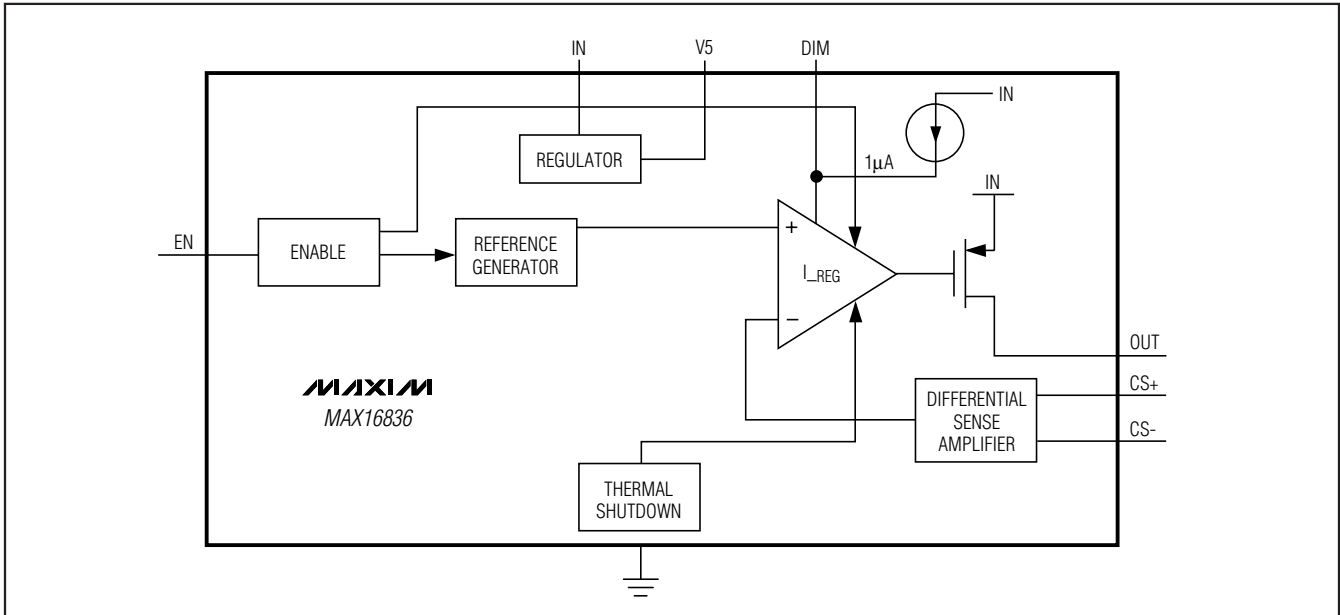

### Detailed Description

The MAX16836 is a high-current regulator capable of providing up to a total of 350mA of current to one or more strings of HB LEDs. A wide operating input voltage range of +6.5V to +40V makes the MAX16836 ideal for automotive applications. A +5V regulated output provides up to 4mA of current to power external circuitry. In addition, the MAX16836 features thermal and output short-circuit protection. The wide operating voltage range helps protect the MAX16836 against large transients such as those found in load-dump situations up to 40V.

The MAX16836 uses a feedback loop to control the output current. The differential voltage across the sense resistor is compared to a fixed reference voltage, and the error is amplified to serve as the drive to the internal power series pass device (see the *Functional Diagram*). The regulation point is factory-set at  $(V_{CS+} - V_{CS-}) = 200\text{mV} \pm 3.5\%$ . The regulated current is user defined by the value of  $R_{SENSE}$ .

The MAX16836 is a current controller internally optimized for driving the impedance range expected from one or more HB LEDs.

### +5V Regulator

The MAX16836 includes a fixed +5V output regulator that delivers up to 4mA of load current throughout the +6.5V to +40V input voltage range. Connect a 0.1µF compensation capacitor from V5 to ground. Shorting V5 to ground disables the thermal shutdown. When EN is low, V5 is off. V5 stays on during PWM dimming, using the DIM input.

### Thermal Protection

The MAX16836 enters a thermal-shutdown mode in the event of overheating. This typically occurs in overload or output short-circuit conditions. If the junction temperature exceeds  $T_J = +159^\circ\text{C}$  (typ), the internal thermal-protection circuitry turns off the series pass device. The MAX16836 recovers from thermal-shutdown mode once the junction temperature drops by  $24^\circ\text{C}$  (typ). The part therefore protects itself by thermally cycling in the event of a short-circuit or overload condition. Shorting V5 to ground disables the thermal shutdown.

### Applications Information

#### Programming the LED Current

The MAX16836 uses a sense resistor across CS+ and CS- to set the LED current. The differential sense amplifier connected across  $R_{SENSE}$  provides ground-loop immunity and low-frequency noise rejection. The LED current is given by:

$$I_{LED} = V_{SENSE}/R_{SENSE}$$

# High-Voltage, 350mA, High-Brightness LED Driver with PWM Dimming and 5V Regulator

## Input-Voltage Considerations

For proper operation, the minimum input voltage must always be:

$$V_{IN(MIN)} \geq V_{SENSE(MAX)} + V_{FT(MAX)} + \Delta V_{DO(MAX)}$$

where  $V_{FT(MAX)}$  is the total forward voltage of all series connected LEDs. The minimum operating voltage of the device is +6.5V. The device operates below +6.5V; however, output current may not meet the full regulation specification.

## Low-Frequency PWM Dimming at the Output

The MAX16836 provides pulsed or chopped current dimming input (DIM). The other method is to connect DIM to V5 and EN to IN and pulse EN. Both methods generate a regulated-amplitude PWM current (variable duty cycle) that can provide control over the LED brightness (see Figures 1 and 2).

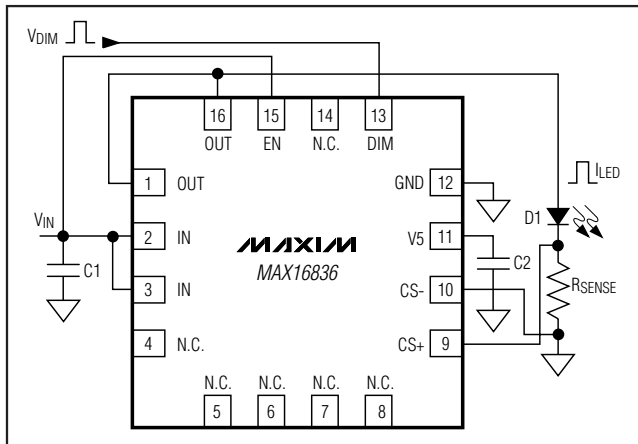

Figure 1. Dimming with EN Connected to  $V_{IN}$  at a Constant Voltage and DIM Pulsed

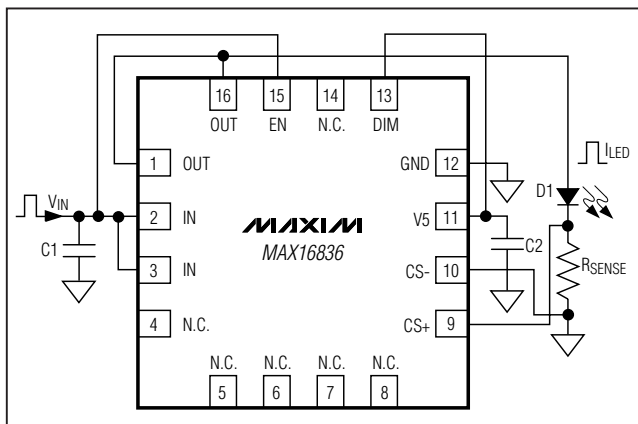

Figure 2. Dimming with DIM Connected to V5, EN Connected to  $V_{IN}$

## Paralleling Multiple MAX16836s to Drive One High-Power LED

For applications that require more than 350mA of LED current, two or more MAX16836s can be paralleled (see Figure 3).  $V_{CS-}$  should not exceed 4.1V.

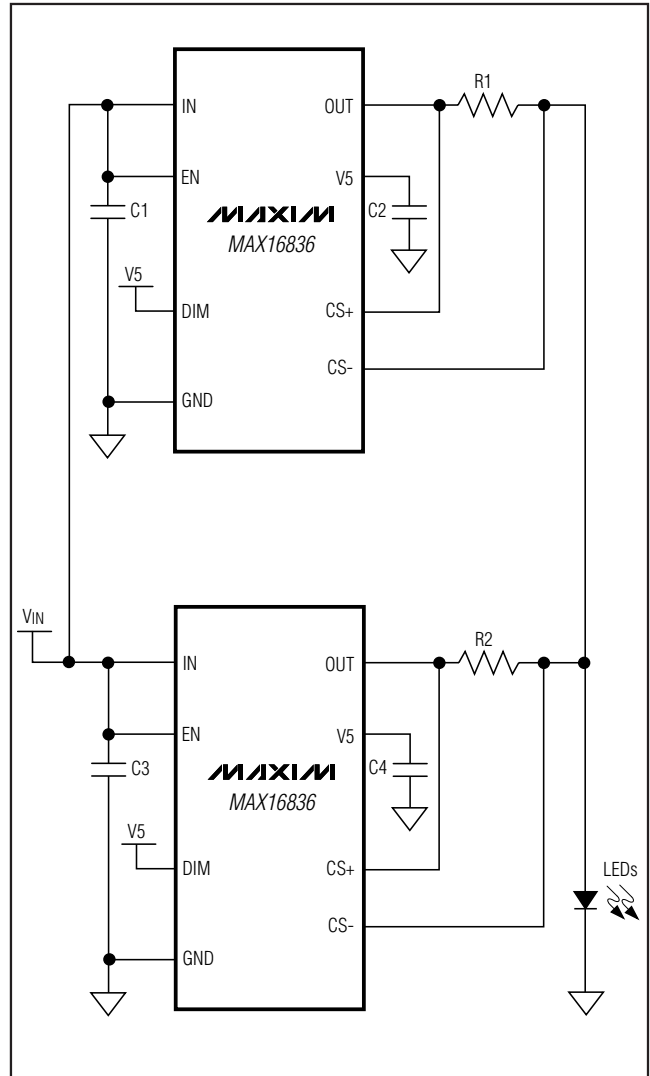

Figure 3. Paralleling MAX16836s

# High-Voltage, 350mA, High-Brightness LED Driver with PWM Dimming and 5V Regulator

## Two Brightness Levels for TAIL/STOP Lights

Figure 4 shows PWM dimming operation for the MAX16836 with an ICM7555 timer. The ICM7555 provides adjustable duty cycle using two external resistors and a capacitor. In TAIL operation, the output of the ICM7555 feeds into DIM and lights up the LEDs. The LED's brightness depends on the duty cycle of the ICM7555. When V<sub>STOP</sub> is present, DIM is pulled up to V<sub>STOP</sub>. The PWM dimming operation is disabled and the LEDs light up to full brightness. See the ICM7555 data sheet for formulas to calculate the dimming frequency and the duty cycle.

## LED Current Thermal Foldback

With a minimum number of external components, the MAX16836 provides LED current thermal foldback using a negative temperature coefficient (NTC) thermistor. Figure 5 shows a thermistor connected to V<sub>5</sub> and the CS+ of the MAX16836. As the temperature increases, the voltage drop across R<sub>2</sub> increases causing the LED current to decrease.

$$I_{LED} = [V_{SENSE} - [R_2 / (R_2 + R_T)] \times V_5] \times \left( \frac{R_T + R_2}{R_T R_1} \right)$$

(assuming  $I_{RT} \ll I_{LED}$ ).

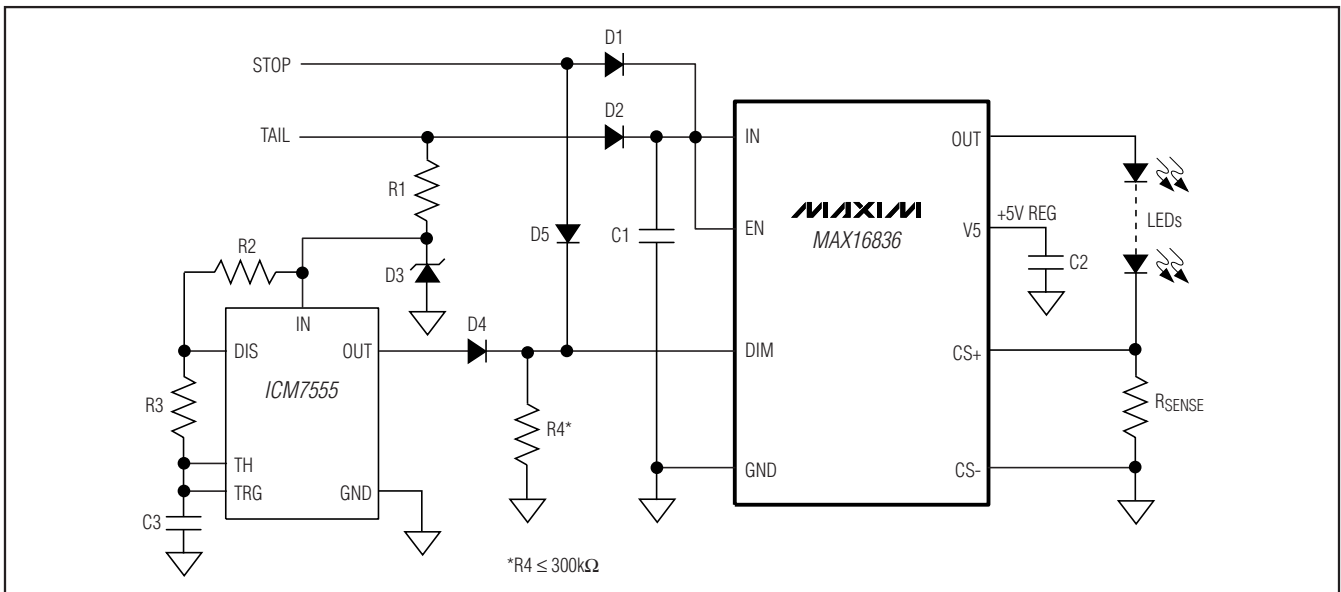

Figure 4. PWM Dimming Operation with ICM7555 Timer

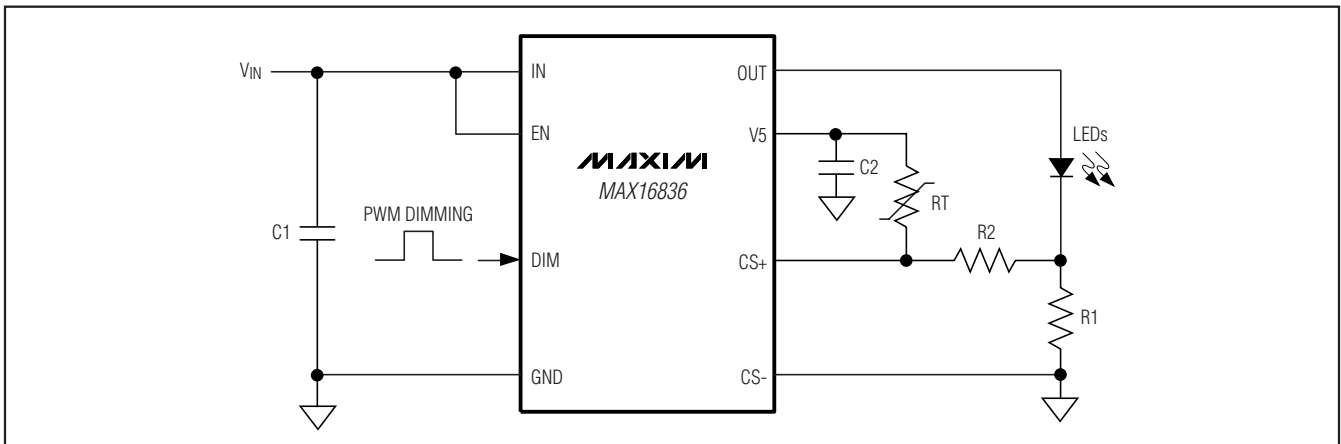

Figure 5. LED Current Thermal Foldback with an NTC Thermistor

# High-Voltage, 350mA, High-Brightness LED Driver with PWM Dimming and 5V Regulator

## Other Applications

The application circuit in Figure 6 implements a two-level brightness current for TAIL/STOP lights. In TAIL operation, Q1 is off and the R1 sets the output current. In STOP operation, Q1 turns on and the output current is set by a parallel combination of R1 and R2.

Figure 7 shows an application circuit with the MAX16836 using a single BJT to provide high output current. For proper operation:

$$V_{IN(MIN)} > V_{CESAT(MAX)} + V_{FT(MAX)} + V_{SENSE}$$

where  $V_{CESAT(MAX)}$  is the maximum saturation voltage of the external BJT.

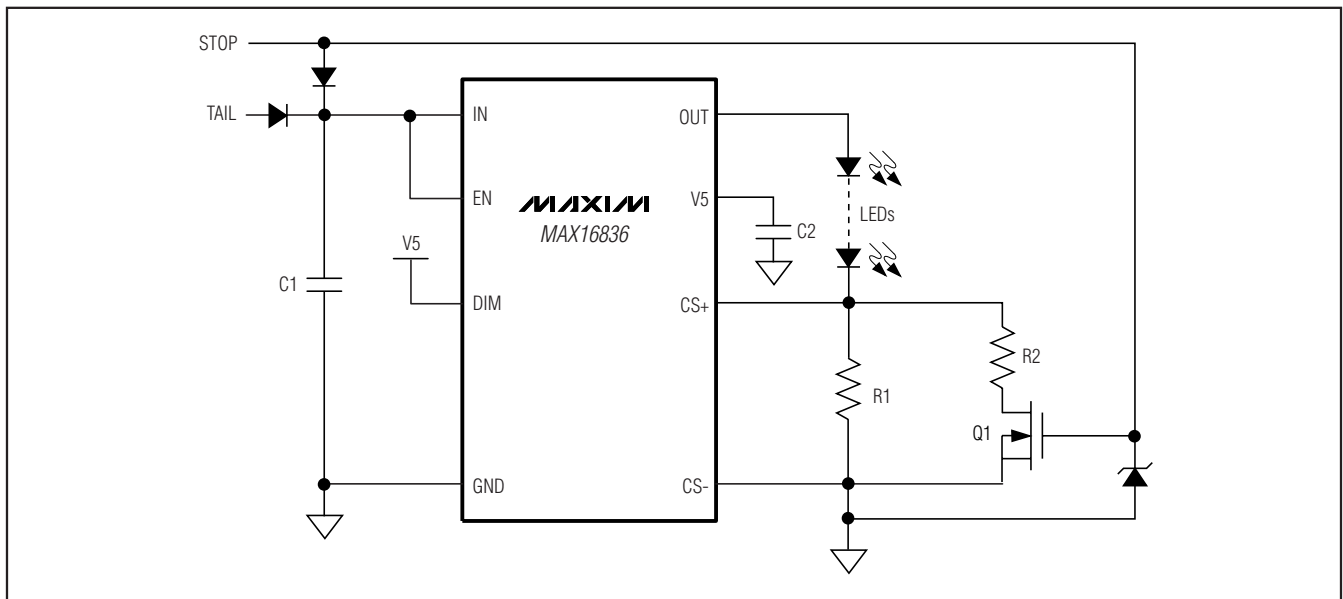

Figure 6. Two Brightness Level with Current Level Switch for Tail/Stop Lights

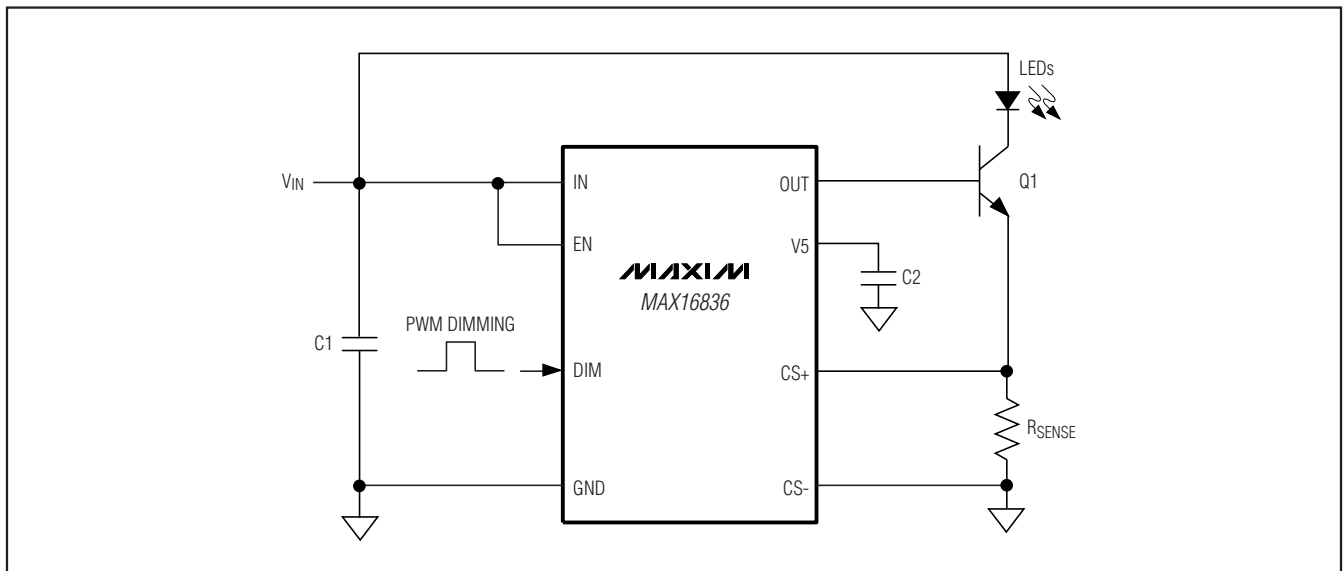

Figure 7. Increased LED Current (Ampere Range) with a Single BJT

# High-Voltage, 350mA, High-Brightness LED Driver with PWM Dimming and 5V Regulator

## Multichannel HB LED Driver

Figure 8 shows an array of MAX16836s with independent DIM control. The MAX5094C, a current-mode PWM

controller, provides the input power to each LED driver preregulated voltage to multiple MAX16836 drivers.

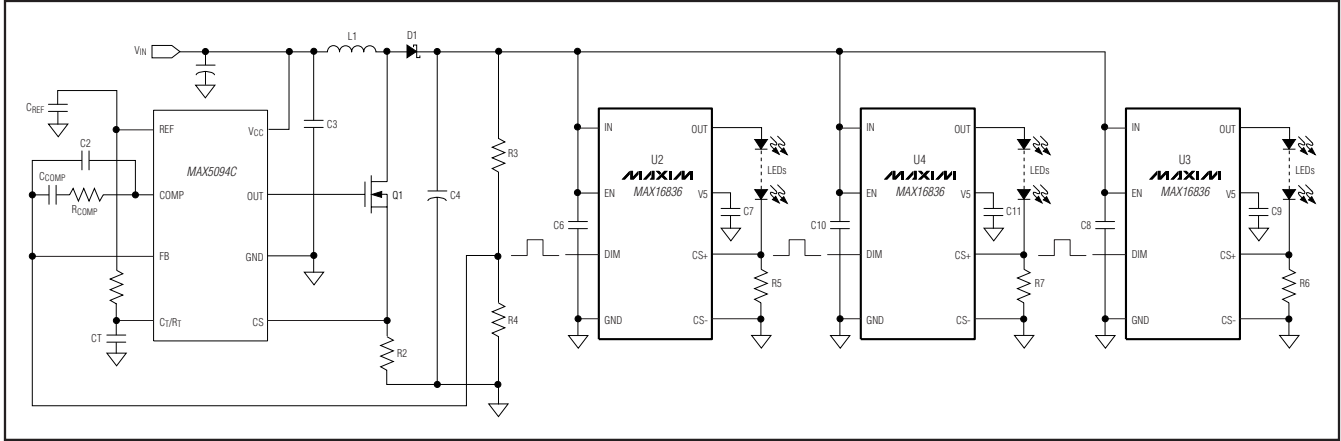
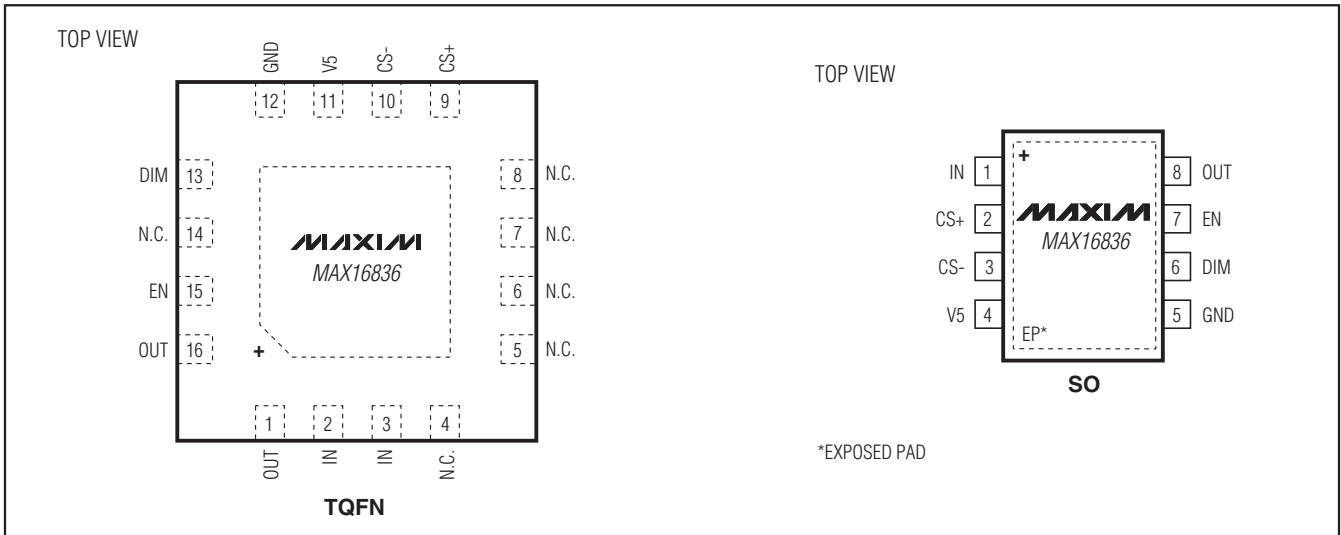

Figure 8. Multichannel HB LED Driver for LCD Backlight

## Pin Configurations



## Chip Information

PROCESS: BICMOS

## Package Information

For the latest package outline information and land patterns, go to [www.maxim-ic.com/packages](http://www.maxim-ic.com/packages).

PACKAGE TYPE	PACKAGE CODE	DOCUMENT NO.
8 SO-EP	S8E-12	<a href="#">21-0111</a>
16 TQFN-EP	T1655-3	<a href="#">21-0140</a>

# High-Voltage, 350mA, High-Brightness LED Driver with PWM Dimming and 5V Regulator

## Revision History

REVISION NUMBER	REVISION DATE	DESCRIPTION	PAGES CHANGED
0	2/08	Initial release	—
1	5/08	Updated <i>Ordering Information, Electrical Characteristics, and Package Information.</i>	1, 2, 11, 12
2	4/09	Added the SO package to the data sheet.	1, 2, 5, 10

MAX16836

Maxim cannot assume responsibility for use of any circuitry other than circuitry entirely embodied in a Maxim product. No circuit patent licenses are implied. Maxim reserves the right to change the circuitry and specifications without notice at any time.

Maxim Integrated Products, 120 San Gabriel Drive, Sunnyvale, CA 94086 408-737-7600 \_\_\_\_\_ 11

## Looking for pricing, stock, or lifecycle information?

Click below to explore more details on WIN SOURCE:

- ⊖ [View MAX16836ASA+T on WIN SOURCE](#)
- ⊖ [Maxim Integrated Information](#)

## Optimize Your Supply Chain with WIN SOURCE Solutions

- ✓ Global Sourcing Solution
- ✓ Obsolete Management
- ✓ Cost Control Management
- ✓ Shortage Management
- ✓ Alternative Solution
- ✓ Excess Inventory Management