



**THE DATASHEET OF
MAX14780EESA+T**



+5.0V, ±30kV ESD-Protected, Fail-Safe, Hot-Swap, RS-485/RS-422 Transceiver

General Description

The MAX14780E is a +5V, ±30kV HBM ESD half duplex RS-485/422 transceiver.

The MAX14780E features reduced slew-rate drivers that minimize EMI and reduce reflections caused by improperly terminated cables, allowing error-free data transmission up to 500kbps.

The MAX14780E is available in an 8-pin SO and PDIP packages operating over a temperature range from -40°C to +85°C.

Applications

Utility Meters
Lighting Systems
Industrial Control
Telecom
Security Systems
Instrumentation

Benefits and Features

Integrated Protection Increases Robustness

- ◆ ±30kV HBM ESD per JEDEC JS-001-2012
- ◆ ±12kV Contact ESD per IEC 61000-4-2
- ◆ ±15kV Air Gap ESD per IEC 61000-4-2
- ◆ True Fail-Safe Receiver Prevents False Transitions on Receiver Input Short or Open
- ◆ Hot Swap Eliminates False Transitions During Power-Up or Hot Insertion
- ◆ Short-Circuit Protected Outputs Low Current Reduces Power Consumption

Low Current Reduces Power Consumption

- ◆ 10µA Shutdown Current
- ◆ 1.2mA of Supply Current When Unloaded

Ordering Information

PART	TEMP RANGE	PIN-PACKAGE
MAX14780EESA+	-40°C to +85°C	8 SO
MAX14780EPEA+	-40°C to +85°C	8 PDIP

+Denotes a lead(Pb)-free/RoHS-compliant package.

Typical Operating Circuit

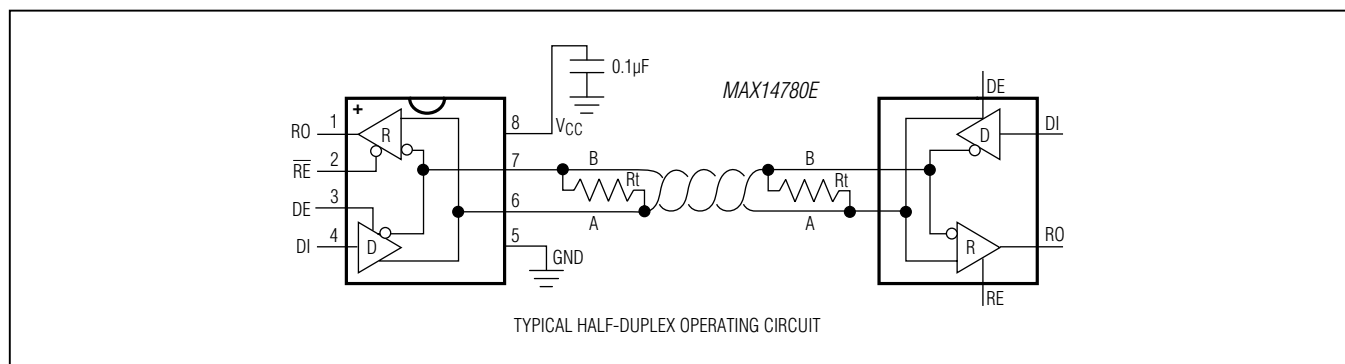

MAX14780E

+5.0V, ±30kV ESD-Protected, Fail-Safe, Hot-Swap, RS-485/RS-422 Transceiver

ABSOLUTE MAXIMUM RATINGS

(All voltages referenced to GND.)

Supply Voltage (VCC).....	+6V
Control Input Voltage (\overline{RE} , DE)	-0.3V to +6V
Driver Input Voltage (DI)	-0.3V to +6V
Driver Output Voltage (A, B)	-8V to +13V
Receiver Input Voltage (A, B)	-8V to +13V
Receiver Output Voltage (RO)	-0.3V to (VCC + 0.3V)
Driver Output Current.....	±250mA

Continuous Power Dissipation (TA = +70°C)

SO (derate 5.9mW/°C above +70°C)	471mW
PDIP (derate 9.1mW/°C above +70°C)	727.3mW
Operating Temperature Range.....	-40°C to +85°C
Junction Temperature	+150°C
Storage Temperature Range.....	-65°C to +150°C
Lead Temperature (soldering, 10s)	+300°C
Soldering Temperature (reflow)	+260°C

Stresses beyond those listed under "Absolute Maximum Ratings" may cause permanent damage to the device. These are stress ratings only, and functional operation of the device at these or any other conditions beyond those indicated in the operational sections of the specifications is not implied. Exposure to absolute maximum rating conditions for extended periods may affect device reliability.

DC ELECTRICAL CHARACTERISTICS

(VCC = +5.0V ±10%, TA = TMIN to TMAX, unless otherwise noted. Typical values are at VCC = +5.0V and TA = +25°C.) (Note 1)

PARAMETER	SYMBOL	CONDITIONS	MIN	TYP	MAX	UNITS
DRIVER						
VCC Supply-Voltage Range	VCC		4.5		5.5	V
Differential Driver Output	VOD	RL = 100Ω (RS-422), Figure 1	3		VCC	V
		RL = 54Ω (RS-485), Figure 1	2		VCC	
		No load			VCC	
Change in Magnitude of Differential Output Voltage	ΔVOD	RL = 100Ω or 54Ω, Figure 1 (Note 2)			0.2	V
Driver Common-Mode Output Voltage	VOC	RL = 100Ω or 54Ω, Figure 1		VCC/2	3	V
Change in Magnitude of Common-Mode Voltage	ΔVOC	RL = 100Ω or 54Ω, Figure 1 (Note 2)			0.2	V
Input-High Voltage	VIH	DE, DI, \overline{RE}	3			V
Input-Low Voltage	VIL	DE, DI, \overline{RE}			0.8	V
Input Hysteresis	VHYS	DE, DI, \overline{RE}		100		mV
Input Current	IIN1	DE, DI, \overline{RE}			±1	μA
Input Impedance First Transition at Power-Up	RPWUP	DE, $\overline{RE} = \overline{RE} = 2V$	3.65		8.8	kΩ
Input Impedance on First Transition after POR Delay	Rft	DE = $\overline{RE} = 2V$	7		60	kΩ
Driver Short-Circuit Output Current	IOSD	0 ≤ VOUT ≤ +12V (Note 3)	40		250	mA
		-7V ≤ VOUT ≤ VCC (Note 3)	-250		-40	
Driver Short-Circuit Foldback Output Current	IOSDF	(VCC - 1V) ≤ VOUT ≤ +12V (Note 3)	20			mA
		-7V ≤ VOUT ≤ +1V (Note 3)			-20	
Thermal-Shutdown Threshold	TTS			175		°C
Thermal-Shutdown Hysteresis	TTSH			15		°C
Input Current (A and B)	IA, B	VDE = 0V, VCC = 0V or VCC	VIN = +12V		125	μA
			VIN = -7V	-100		
RECEIVER						
Receiver Differential Threshold Voltage	VTH	-7V ≤ VCM ≤ +12V	-200	-125	-50	mV
Receiver Input Hysteresis	ΔVTH	VA + VB = 0V		15		mV

MAX14780E

+5.0V, ±30kV ESD-Protected, Fail-Safe, Hot-Swap, RS-485/RS-422 Transceiver

DC ELECTRICAL CHARACTERISTICS (continued)

($V_{CC} = +5.0V \pm 10\%$, $T_A = T_{MIN}$ to T_{MAX} , unless otherwise noted. Typical values are at $V_{CC} = +5.0V$ and $T_A = +25^\circ C$.) (Note 1)

PARAMETER	SYMBOL	CONDITIONS	MIN	TYP	MAX	UNITS
RO Output-High Voltage	V_{OH}	$I_O = -1mA$	$V_{CC} - 0.6$		V	
RO Output-Low Voltage	V_{OL}	$I_O = 1mA$			0.4	V
Three-State Output Current at Receiver	I_{OZR}	$0 \leq V_O \leq V_{CC}$			≤ 1	μA
Receiver Input Resistance	R_{IN}	$-7V \leq V_{CM} \leq +12V$	96			$k\Omega$
Receiver Output Short-Circuit Current	I_{OSR}	$0V \leq V_{RO} \leq V_{CC}$			≤ 110	mA
SUPPLY CURRENT						
Supply Current	I_{CC}	No load, $\overline{V_{RE}} = 0V$, $DE = V_{CC}$		1.2	1.8	mA
		No load, $\overline{RE} = V_{CC}$, $DE = V_{CC}$		1.2	1.8	
		No load, $\overline{V_{RE}} = 0V$, $V_{DE} = 0V$		1.2	1.8	
Supply Current in Shutdown Mode	I_{SHDN}	$\overline{RE} = V_{CC}$, $V_{DE} = 0V$		2.8	10	μA
ESD PROTECTION						
ESD Protection for A and B		Human Body Model		± 30		kV
		Contact Discharge IEC 61000-4-2		± 12		
		Air-Gap Discharge IEC 61000-4-2		± 15		

DRIVER SWITCHING CHARACTERISTICS WITH INTERNAL SRL (500kbps)

($V_{CC} = +5.0V \pm 10\%$, $T_A = T_{MIN}$ to T_{MAX} , unless otherwise noted. Typical values are at $V_{CC} = +5.0V$ and $T_A = +25^\circ C$.) (Note 1)

PARAMETER	SYMBOL	CONDITIONS	MIN	TYP	MAX	UNITS
Driver Propagation Delay	t_{DPLH}	$C_L = 50pF$, $R_L = 54\Omega$, Figures 2 and 3	200		1000	ns
	t_{DPLH}		200		1000	
Driver Differential Output Rise or Fall Time	t_R , t_F	$C_L = 50pF$, $R_L = 54\Omega$, Figures 2 and 3	250		900	ns
Differential Driver Output Skew $ t_{DPLH} - t_{DPLH} $	t_{DSKEW}	$C_L = 50pF$, $R_L = 54\Omega$, Figures 2 and 3			140	ns
Maximum Data Rate			500			kbps
Driver Enable to Output High	t_{DZH}	Figure 4			2500	ns
Driver Enable to Output Low	t_{DZL}	Figure 5			2500	ns
Driver Disable Time from Low	t_{DLZ}	Figure 5			100	ns
Driver Disable Time from High	t_{DHZ}	Figure 4			100	ns
Driver Enable from Shutdown to Output High	$t_{DZH(SHDN)}$	Figure 4			5500	ns
Driver Enable from Shutdown to Output Low	$t_{DZL(SHDN)}$	Figure 5			5500	ns
Time to Shutdown	t_{SHDN}		50	340	700	ns

MAX14780E

+5.0V, ±30kV ESD-Protected, Fail-Safe, Hot-Swap, RS-485/RS-422 Transceiver

RECEIVER SWITCHING CHARACTERISTICS WITH INTERNAL SRL (500kbps)

(VCC = +5.0V ±10%, TA = TMIN to TMAX, unless otherwise noted. Typical values are at VCC = +5.0V and TA = +25°C.) (Note 1)

PARAMETER	SYMBOL	CONDITIONS	MIN	TYP	MAX	UNITS
Receiver Propagation Delay	tRPLH	CL = 15pF, Figures 6 and 7			200	ns
	tRPHL				200	
Receiver Output Skew tRPLH - tRPHL	tRSKEW	CL = 15pF, Figures 6 and 7			30	ns
Maximum Data Rate			500			kbps
Receiver Enable to Output Low	tRZL	Figure 8			50	ns
Receiver Enable to Output High	tRZH	Figure 8			50	ns
Receiver Disable Time from Low	tRLZ	Figure 8			50	ns
Receiver Disable Time from High	tRHZ	Figure 8			50	ns
Receiver Enable from Shutdown to Output High	tRZH(SHDN)	Figure 8			5500	ns
Receiver Enable from Shutdown to Output Low	tRZL(SHDN)	Figure 8			5500	ns
Time to Shutdown	tSHDN		50	340	700	ns

Note 1: All currents into the device are positive. All currents out of the device are negative. All voltages are referred to device ground, unless otherwise noted.

Note 2: ΔVOD and ΔVOC are the changes in VOD and VOC, respectively, when the DI input changes state.

Note 3: The short-circuit output current applies to peak current just prior to foldback current limiting. The short-circuit foldback output current applies during current limiting to allow a recovery from bus contention.

Test Circuits and Waveforms

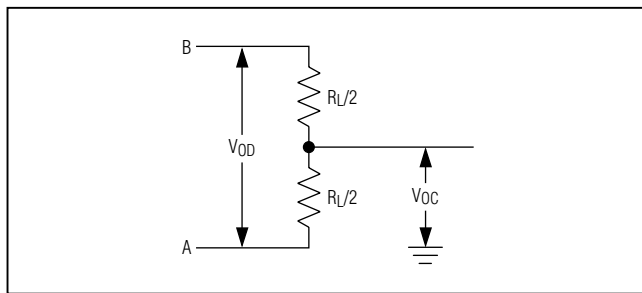

Figure 1. Driver DC Test Load

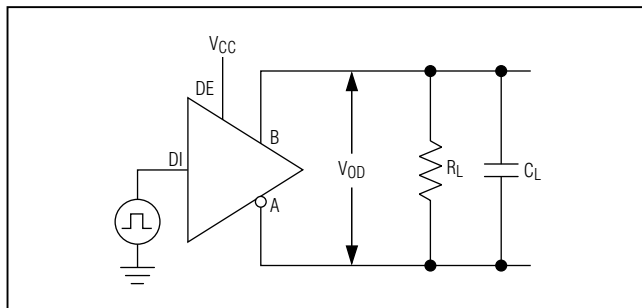

Figure 2. Driver Timing Test Circuit

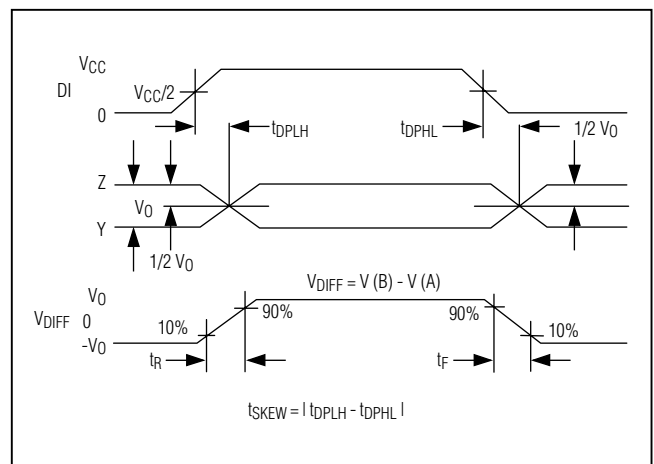

Figure 3. Driver Propagation Delays

MAX14780E

+5.0V, ±30kV ESD-Protected, Fail-Safe, Hot-Swap, RS-485/RS-422 Transceiver

Test Circuits and Waveforms (continued)

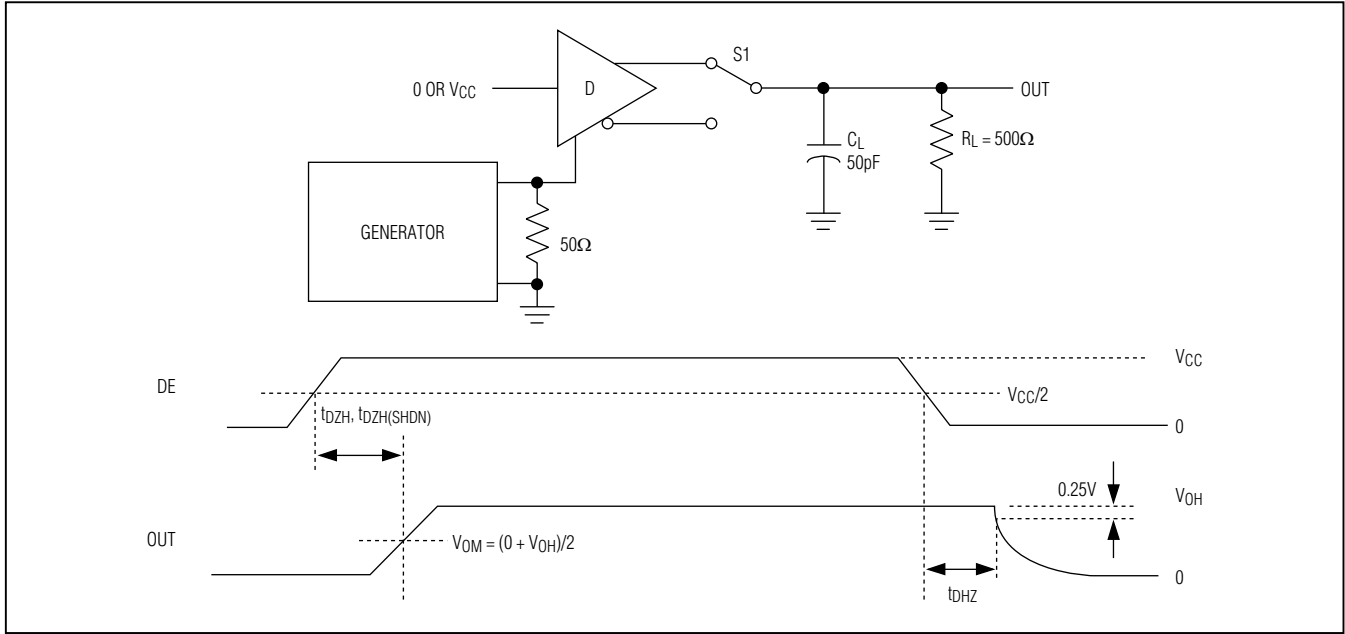

Figure 4. Driver Enable and Disable Times (t_{DZH} , $t_{DZH(SHDN)}$, t_{DZL})

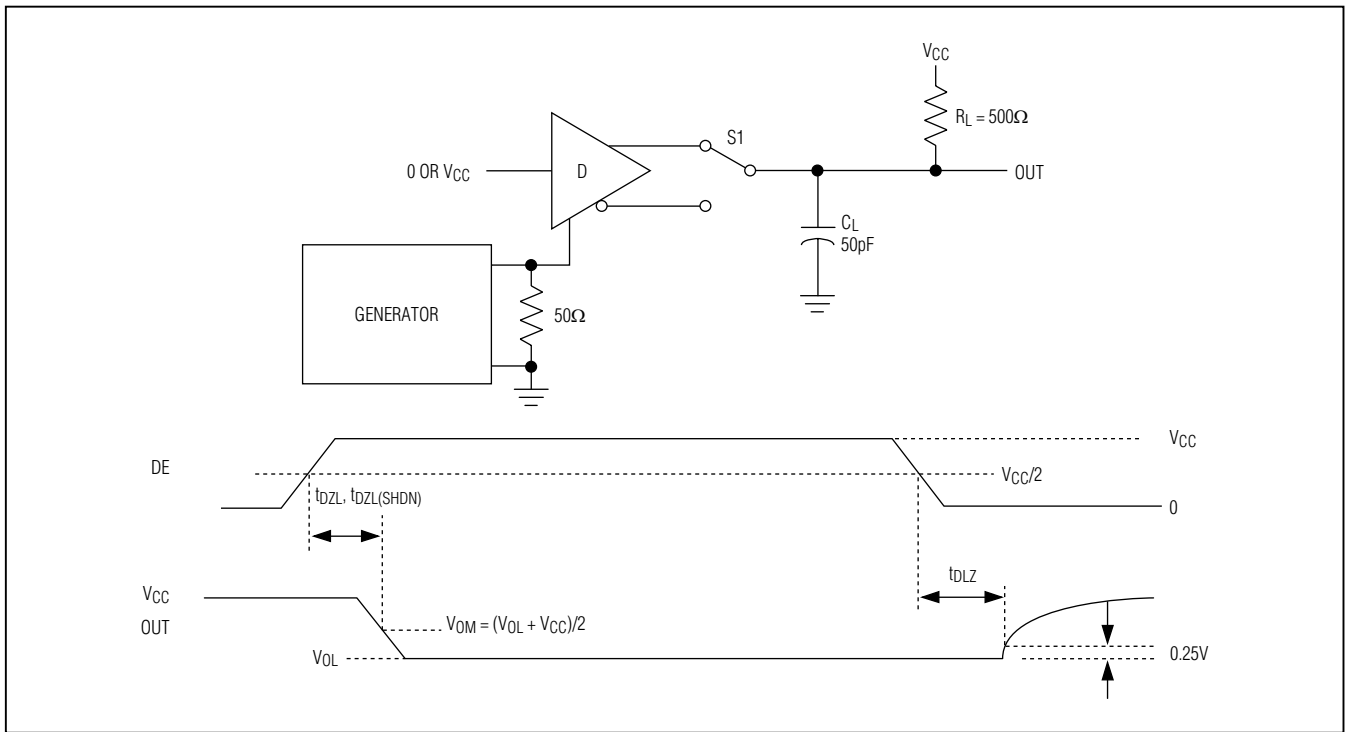

Figure 5. Driver Enable and Disable Times (t_{DLZ} , $t_{DLZ(SHDN)}$, t_{DLZ})

MAX14780E

+5.0V, ±30kV ESD-Protected, Fail-Safe, Hot-Swap, RS-485/RS-422 Transceiver

Test Circuits and Waveforms (continued)

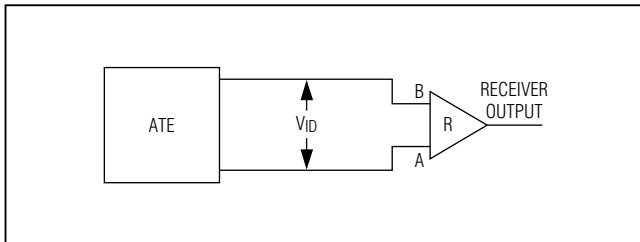

Figure 6. Receiver Propagation Delay Test Circuit

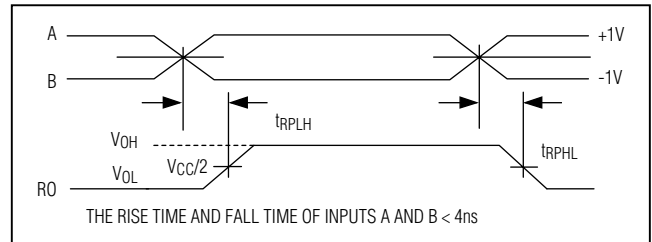

Figure 7. Receiver Propagation Delays

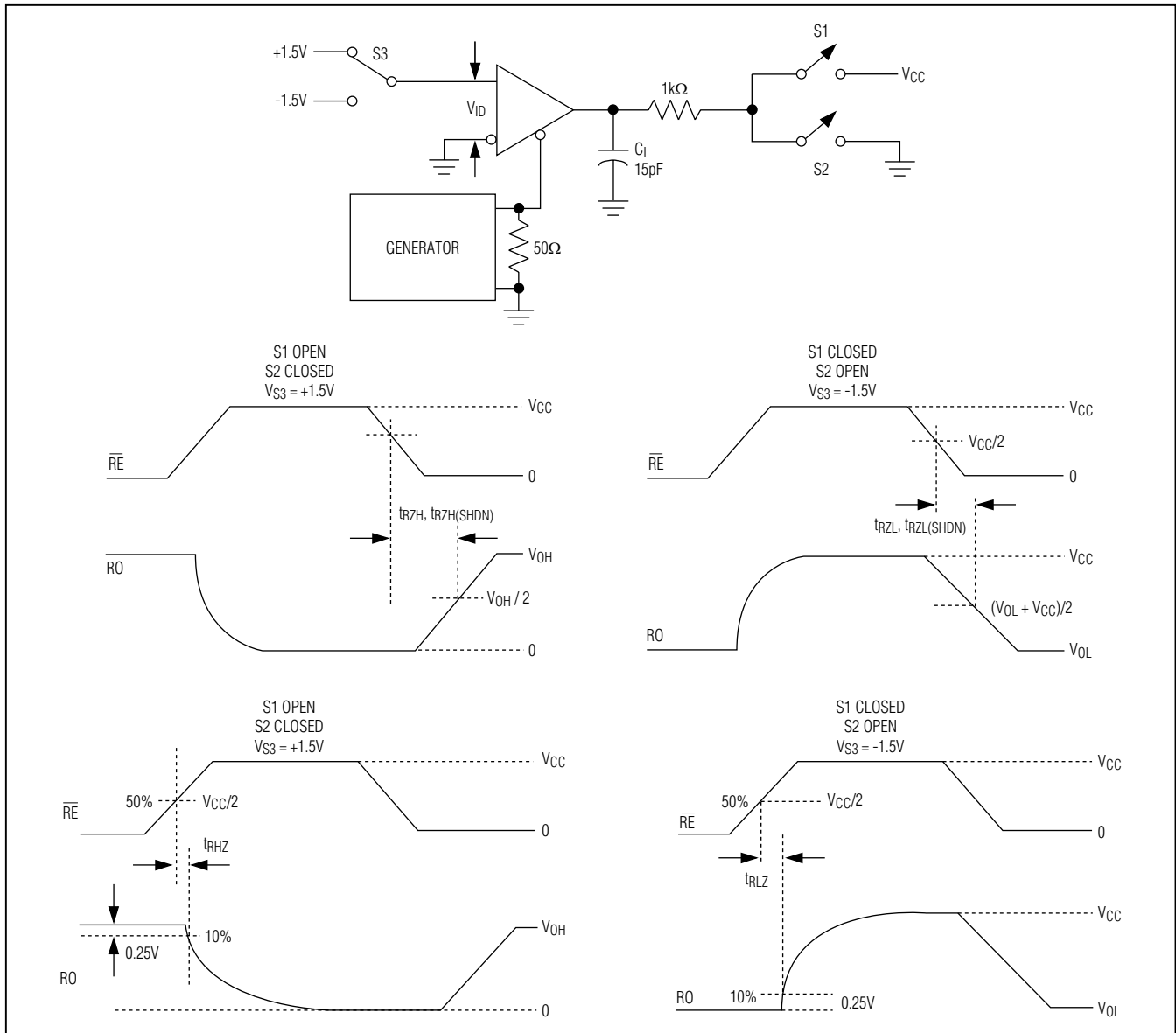

Figure 8. Receiver Enable and Disable Times

MAX14780E

+5.0V, ±30kV ESD-Protected, Fail-Safe, Hot-Swap, RS-485/RS-422 Transceiver

Typical Operating Characteristics

($V_{CC} = +5.0V$, $T_A = +25^{\circ}C$, unless otherwise noted.)

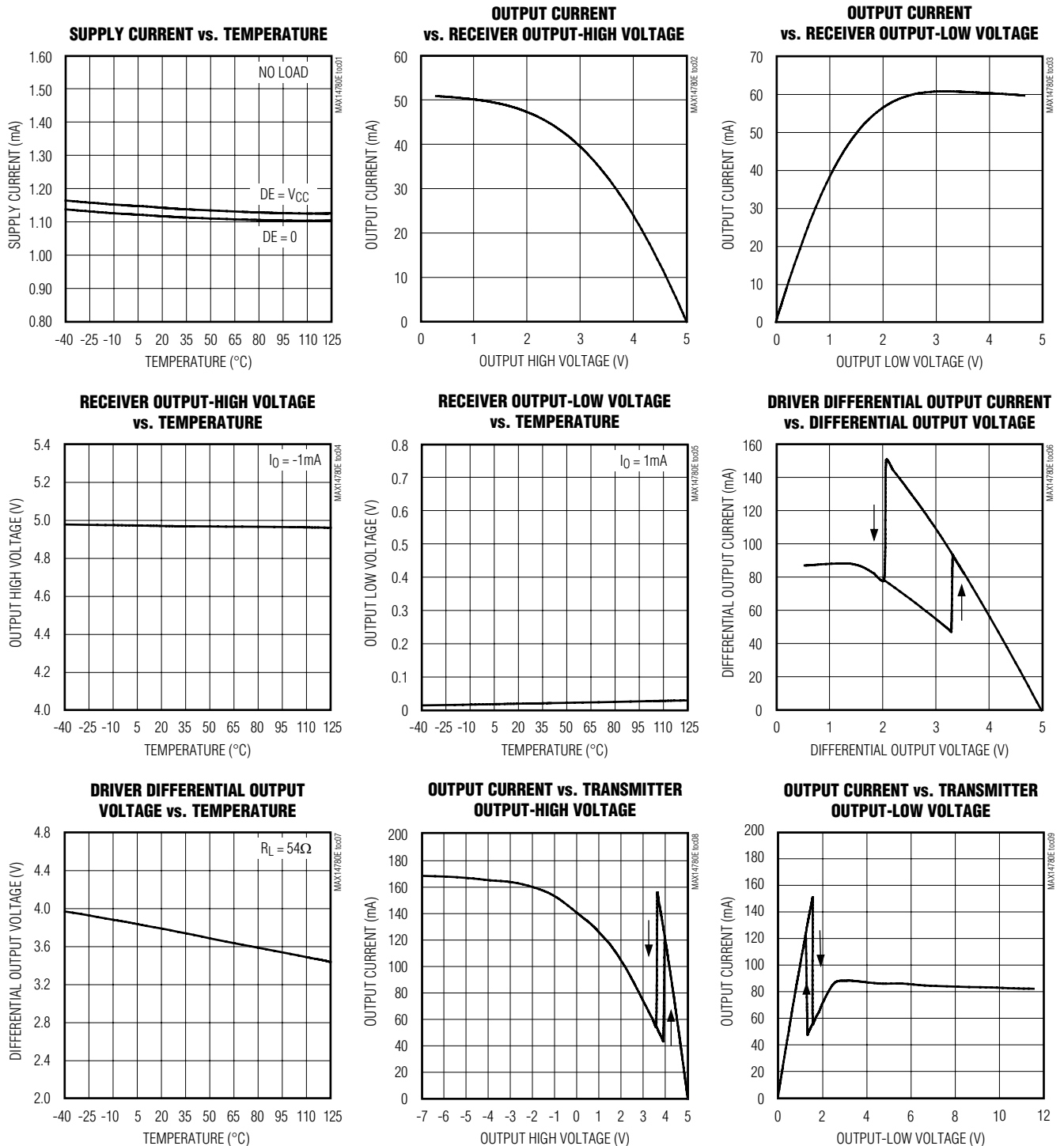

MAX14780E

+5.0V, ±30kV ESD-Protected, Fail-Safe, Hot-Swap, RS-485/RS-422 Transceiver

Typical Operating Characteristics (continued)

(VCC = +5.0V, TA = +25°C, unless otherwise noted.)

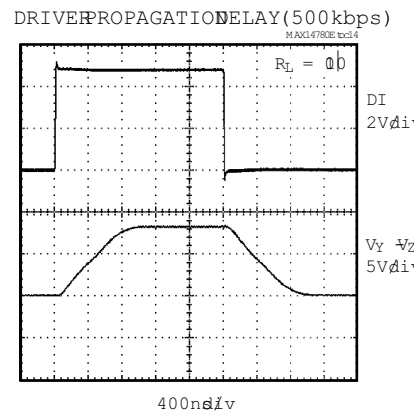
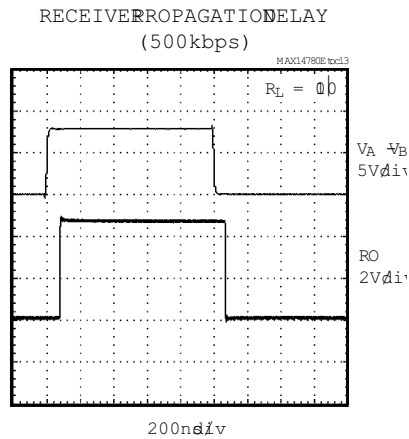
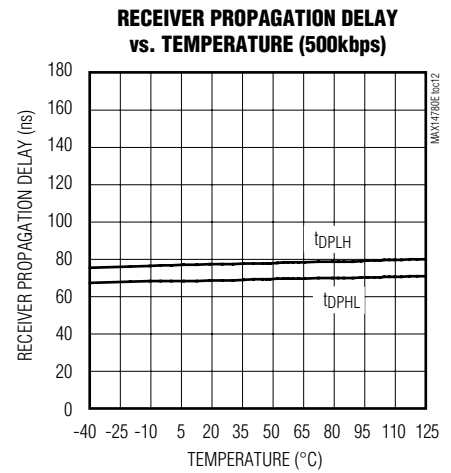
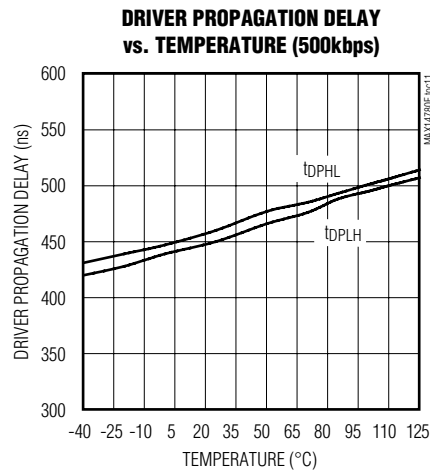
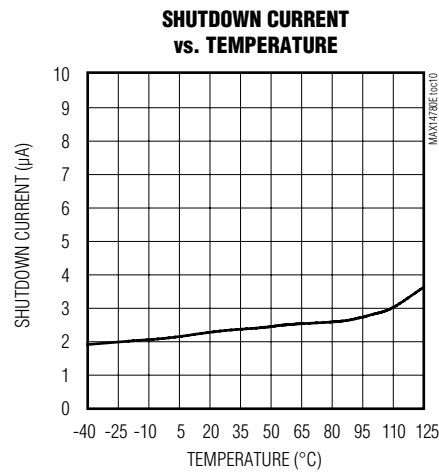

MAX14780E

+5.0V, ±30kV ESD-Protected, Fail-Safe, Hot-Swap, RS-485/RS-422 Transceiver

Pin Configuration

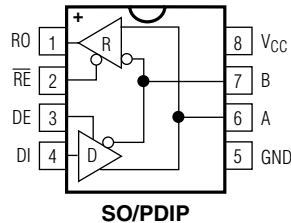

Pin Description

PIN	NAME	FUNCTION
1	RO	Receiver Output. When \overline{RE} is low and if $(A - B) \geq -50\text{mV}$, RO is high; if $(A - B) \leq -200\text{mV}$, RO is low.
2	\overline{RE}	Receiver Output Enable. Drive \overline{RE} low to enable RO; RO is high impedance when \overline{RE} is high. Drive \overline{RE} high and DE low to enter low-power shutdown mode. \overline{RE} is a hot-swap input (see the <i>Hot-Swap Capability</i> section for details).
3	DE	Driver Output Enable. Drive DE high to enable driver outputs. These outputs are high impedance when DE is low. Drive \overline{RE} high and DE low to enter low-power shutdown mode. DE is a hot-swap input (see the <i>Hot-Swap Capability</i> section for details).
4	DI	Driver Input. With DE high, a low on DI forces noninverting output low and inverting output high. Similarly, a high on DI forces noninverting output high and inverting output low.
5	GND	Ground
6	A	Noninverting Receiver Input and Noninverting Driver Output
7	B	Inverting Receiver Input and Inverting Driver Output
8	VCC	Positive Supply $V_{CC} = +5.0\text{V} \pm 10\%$. Bypass V_{CC} to GND with a $0.1\mu\text{F}$ capacitor.

Function Tables

TRANSMITTING				
INPUTS			OUTPUTS	
\overline{RE}	DE	DI	B	A
X	1	1	0	1
X	1	0	1	0
0	0	X	High-Z	High-Z
1	0	X	Shutdown	

RECEIVING			
INPUTS			OUTPUTS
\overline{RE}	DE	A-B	RO
0	X	$\geq -50\text{mV}$	1
0	X	$\leq -200\text{mV}$	0
0	X	Open/shorted	1
1	1	X	High-Z
1	0	X	Shutdown

MAX14780E

+5.0V, ±30kV ESD-Protected, Fail-Safe, Hot-Swap, RS-485/RS-422 Transceiver

Detailed Description

The MAX14780E high-speed transceiver for RS-485/RS-422 communication contains one driver and one receiver. This device features fail-safe circuitry, which guarantees a logic-high receiver output when the receiver inputs are open or shorted, or when they are connected to a terminated transmission line with all drivers disabled (see the *Fail-Safe* section). The MAX14780E also features a hot-swap capability allowing line insertion without erroneous data transfer (see the *Hot-Swap Capability* section). The MAX14780E features reduced slew-rate drivers that minimize EMI and reduce reflections caused by improperly terminated cables, allowing error-free data transmission up to 500kbps.

The MAX14780E is a half-duplex transceiver and operates from a single +5.0V supply. Drivers are output short-circuit current limited. Thermal-shutdown circuitry protects drivers against excessive power dissipation. When activated, the thermal-shutdown circuitry places the driver outputs into a high-impedance state.

Fail-Safe

The MAX14780E guarantees a logic-high receiver output when the receiver inputs are shorted or open, or when they are connected to a terminated transmission line with all drivers disabled. This is done by setting the receiver input threshold between -50mV and -200mV. If the differential receiver input voltage ($A - B$) is greater than or equal to -50mV, RO is logic-high. If ($A - B$) is less than or equal to -200mV, RO is logic-low. In the case of a terminated bus with all transmitters disabled, the receiver's differential input voltage is pulled to 0V by the termination. With the receiver threshold of the MAX14780E, this results in a logic-high with a 50mV minimum noise margin. Unlike previous fail-safe devices, the -50mV to -200mV threshold complies with the ±200mV EIA/TIA-485 standard.

Hot-Swap Capability

Hot-Swap Inputs

When circuit boards are inserted into a hot or powered backplane, differential disturbances to the data bus can lead to data errors. Upon initial circuit board insertion, the data communication processor undergoes its own power-up sequence. During this period, the processor's logic-output drivers are high impedance and are unable to drive the DE and \overline{RE} inputs of these devices to a defined logic level. Leakage currents up to ±10µA from the high-impedance state of the processor's logic drivers could cause standard CMOS enable inputs of a transceiver to drift to an incorrect logic level.

Additionally, parasitic circuit board capacitance could cause coupling of VCC or GND to the enable inputs. Without the hot-swap capability, these factors could improperly enable the transceiver's driver or receiver.

When VCC rises, an internal pulldown circuit holds DE low and \overline{RE} high. After the initial power-up sequence, the pulldown circuit becomes transparent, resetting the hot-swap tolerable input.

Hot-Swap Input Circuitry

The enable inputs feature hot-swap capability. At the input there are two nMOS devices, M1 and M2 (Figure 9). When VCC ramps from zero, an internal 7µs timer turns on M2 and sets the SR latch, which also turns on M1. Transistors M2, a 500µA current sink, and M1, a 100µA current sink, pull DE to GND through a 5kΩ resistor. M2 is designed to pull DE to the disabled state against an external parasitic capacitance up to 100pF that can drive DE high. After 7µs, the timer deactivates M2 while M1 remains on, holding DE low against three-state leakages that can drive DE high. M1 remains on until an external source overcomes the required input current. At this time, the SR latch resets and M1 turns off. When M1 turns off, DE reverts to a standard, high-impedance

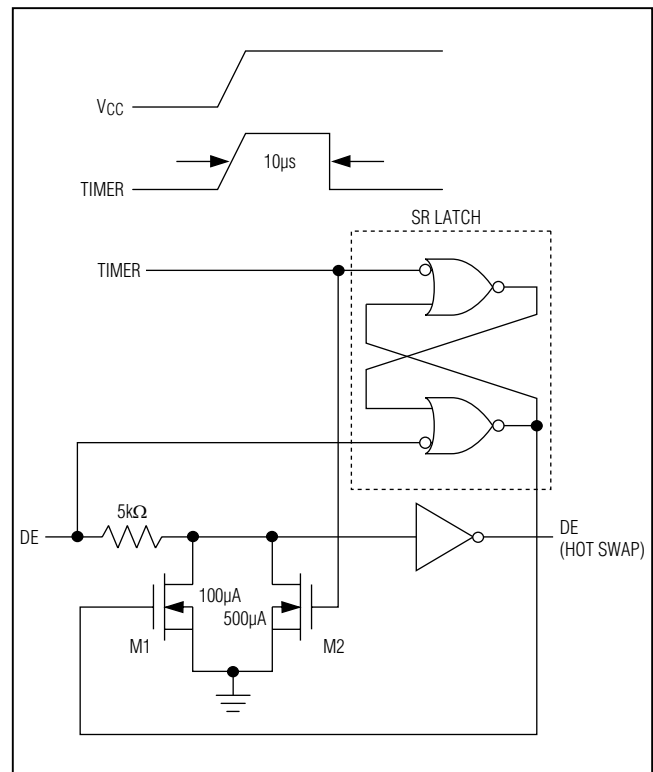

Figure 9. Simplified Structure of the Driver Enable Pin (DE)

MAX14780E

+5.0V, ±30kV ESD-Protected, Fail-Safe, Hot-Swap, RS-485/RS-422 Transceiver

CMOS input. Whenever V_{CC} drops below 1V, the hot-swap input is reset.

For \overline{RE} there is a complementary circuit employing two pMOS devices pulling \overline{RE} to V_{CC} .

±30kV ESD Protection

As with all Maxim devices, ESD-protection structures are incorporated on all pins to protect against electrostatic discharges encountered during handling and assembly. The driver output and receiver input of the MAX14780E have extra protection against static electricity. Maxim's engineers have developed state-of-the-art structures to protect these pins against ESD of ±30kV without damage. The ESD structures withstand high ESD in all states: normal operation, shutdown, and powered down. After an ESD event, the MAX14780E keeps working without latchup or damage.

ESD protection can be tested in various ways. The transmitter output and receiver input of the MAX14780E are characterized for protection to the following limits:

- ±30kV using the Human Body Model
- ±12kV using the Contact Discharge method specified in IEC 61000-4-2
- ±15kV using the Air-Gap Discharge method specified in IEC 61000-4-2

ESD Test Conditions

ESD performance depends on a variety of conditions. Contact Maxim for a reliability report that documents test setup, test methodology, and test results.

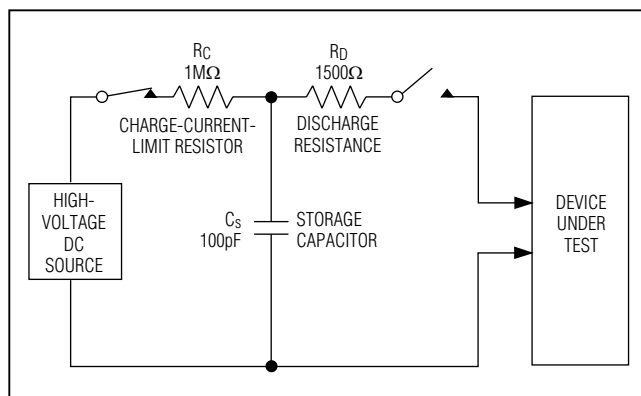

Figure 10a. Human Body ESD Test Model

Human Body Model

Figure 10a shows the Human Body Model, and Figure 10b shows the current waveform it generates when discharged into a low impedance. This model consists of a 100pF capacitor charged to the ESD voltage of interest, which is then discharged into the test device through a 1.5kΩ resistor.

IEC 61000-4-2

The IEC 61000-4-2 standard covers ESD testing and performance of finished equipment. However, it does not specifically refer to integrated circuits. The MAX14780E helps you design equipment to meet IEC 61000-4-2, without the need for additional ESD-protection components.

The major difference between tests done using the Human Body Model and IEC 61000-4-2 is higher peak current in IEC 61000-4-2 because series resistance is lower in the IEC 61000-4-2 model. Hence, the ESD withstand voltage measured to IEC 61000-4-2 is generally lower than that measured using the Human Body Model. Figure 10c shows the IEC 61000-4-2 model, and Figure 10d shows the current waveform for IEC 61000-4-2 ESD Contact Discharge test.

Machine Model

The machine model for ESD tests all pins using a 200pF storage capacitor and zero discharge resistance. The objective is to emulate the stress caused when I/O pins are contacted by handling equipment during test and assembly. Of course, all pins require this protection, not just RS-485 inputs and outputs.

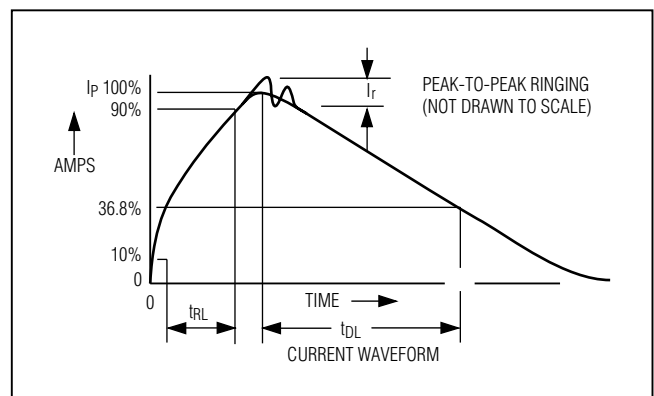

Figure 10b. Human Body Current Waveform

MAX14780E

+5.0V, ±30kV ESD-Protected, Fail-Safe, Hot-Swap, RS-485/RS-422 Transceiver

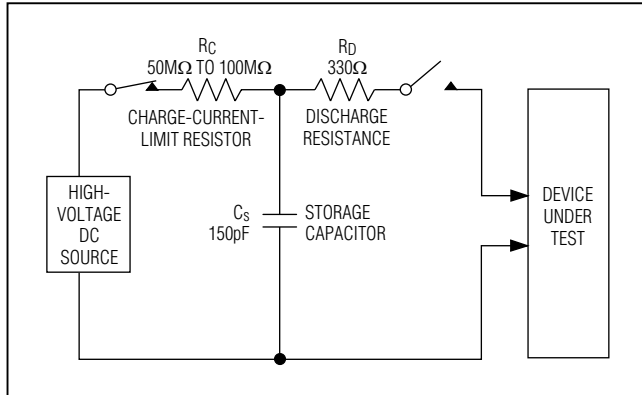

Figure 10c. IEC 61000-4-2 ESD Test Model

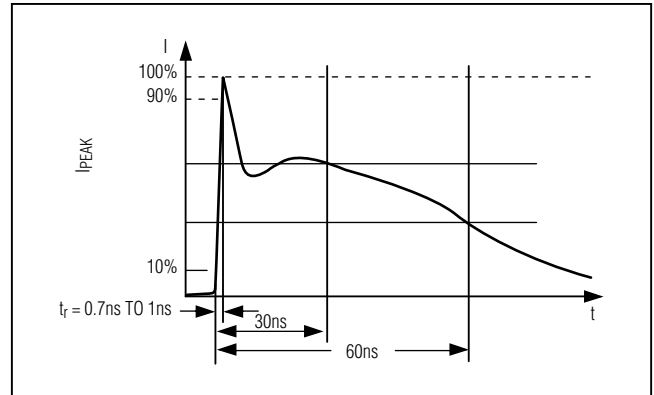

Figure 10d. IEC 61000-4-2 ESD Generator Current Waveform

Applications Information

The standard RS-485 receiver input impedance is $12\text{k}\Omega$ (1-unit load), and the standard driver can drive up to 32-unit loads. The MAX14780E has a 1/8-unit load receiver input impedance ($96\text{k}\Omega$), allowing up to 256 transceivers to be connected in parallel on one communication line. Any combination of the MAX14780E, as well as other RS-485 transceivers with a total of 32-unit loads or fewer, can be connected to the line.

Reduced EMI and Reflections

The MAX14780E features reduced slew-rate drivers that minimize EMI and reduce reflections caused by improperly terminated cables, allowing error-free data transmission up to 500kbps.

Low-Power Shutdown Mode

Low-power shutdown mode is initiated by bringing both $\overline{\text{RE}}$ high and DE low. In shutdown, the devices typically draw only $2.8\mu\text{A}$ of supply current.

$\overline{\text{RE}}$ and DE can be driven simultaneously; the devices are guaranteed not to enter shutdown if $\overline{\text{RE}}$ is high and DE is low for less than 50ns. If the inputs are in this state for at least 700ns, the devices are guaranteed to enter shutdown.

Enable times t_{ZH} and t_{ZL} (see the *Switching Characteristics* section) assume the devices were not in a low-power shutdown state. Enable times $t_{\text{ZH}}(\text{SHDN})$ and $t_{\text{ZL}}(\text{SHDN})$ assume the devices were in shutdown state. It takes drivers and receivers longer to become enabled from low-power shutdown mode ($t_{\text{ZH}}(\text{SHDN})$, $t_{\text{ZL}}(\text{SHDN})$) than from driver/receiver-disable mode (t_{ZH} , t_{ZL}).

Driver Output Protection

Two mechanisms prevent excessive output current and power dissipation caused by faults or by bus contention. The first, a foldback current limit on the output stage, provides immediate protection against short circuits over the whole common-mode voltage range (see the *Typical Operating Characteristics*). The second, a thermal-shutdown circuit, forces the driver outputs into a high-impedance state if the die temperature exceeds $+175^\circ\text{C}$ (typ).

Line Length

The RS-485/RS-422 standard covers line lengths up to 4000ft. For line lengths greater than 4000ft, it may be necessary to implement a line repeater.

MAX14780E

+5.0V, ±30kV ESD-Protected, Fail-Safe, Hot-Swap, RS-485/RS-422 Transceiver

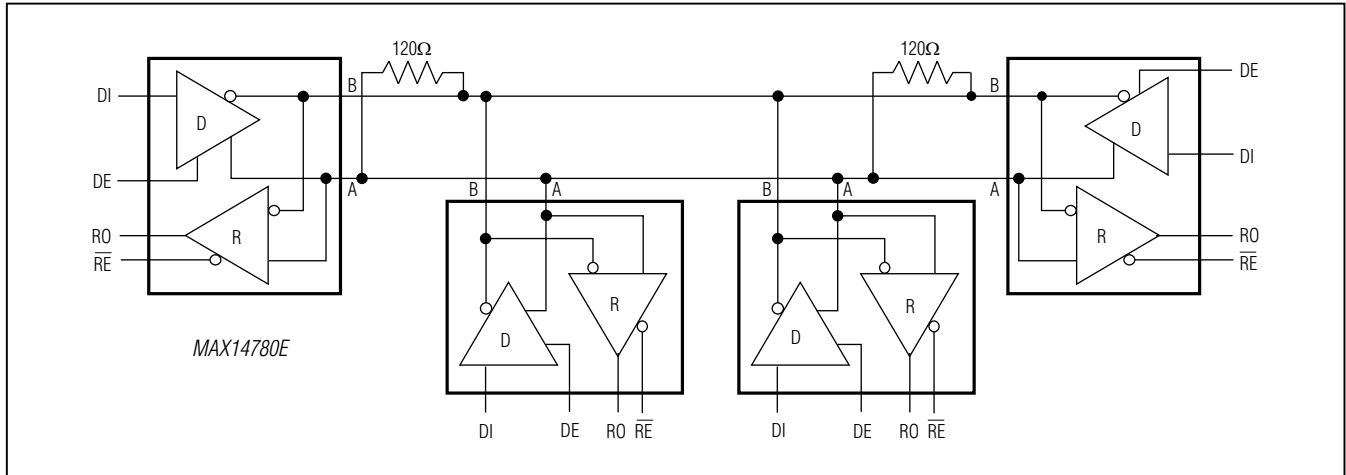

Figure 11. Typical Half-Duplex RS-485 Network

Typical Applications

The MAX14780E transceiver is designed for bidirectional data communications on multipoint bus transmission lines. Figure 11 shows a typical network applications circuit.

To minimize reflections, terminate the line at both ends in its characteristic impedance, and keep stub lengths off the main line as short as possible. The slew-rate-limited MAX14780E is more tolerant of imperfect termination.

Chip Information

PROCESS: BiCMOS

Package Information

For the latest package outline information and land patterns (footprints), go to www.maximintegrated.com/packages. Note that a "+", "#", or "-" in the package code indicates RoHS status only. Package drawings may show a different suffix character, but the drawing pertains to the package regardless of RoHS status.

PACKAGE TYPE	PACKAGE CODE	OUTLINE NO.	LAND PATTERN NO.
8 SO	S8+4	21-0041	90-0096
8 PDIP	P8+2	21-0043	—

MAX14780E

+5.0V, ±30kV ESD-Protected, Fail-Safe, Hot-Swap, RS-485/RS-422 Transceiver

Revision History

REVISION NUMBER	REVISION DATE	DESCRIPTION	PAGES CHANGED
0	12/10	Initial release	—
1	7/11	Added PDIP package information to data sheet	1, 2, 9, 13
2	10/11	Updated <i>DC Electrical Characteristics</i> including adding new row for Input Impedance on First Transition after POR Delay, updated <i>Hot-Swap Input Circuitry</i> section	2, 10
3	1/15	Updated <i>General Description</i> and <i>Benefits and Features</i> sections	1



Maxim Integrated cannot assume responsibility for use of any circuitry other than circuitry entirely embodied in a Maxim Integrated product. No circuit patent licenses are implied. Maxim Integrated reserves the right to change the circuitry and specifications without notice at any time. The parametric values (min and max limits) shown in the Electrical Characteristics table are guaranteed. Other parametric values quoted in this data sheet are provided for guidance.

Looking for pricing, stock, or lifecycle information?

Click below to explore more details on WIN SOURCE:

- ⊖ [View MAX14780EESA+T on WIN SOURCE](#)
- ⊖ [Maxim Integrated Information](#)

Optimize Your Supply Chain with WIN SOURCE Solutions

- ✓ Global Sourcing Solution
- ✓ Obsolete Management
- ✓ Cost Control Management
- ✓ Shortage Management
- ✓ Alternative Solution
- ✓ Excess Inventory Management