



# THE DATASHEET OF MAX1202BCAP+T



## MAX1202/MAX1203

## 5V, 8-Channel, Serial, 12-Bit ADCs with 3V Digital Interface

### General Description

The MAX1202/MAX1203 are 12-bit data-acquisition systems specifically designed for use in applications with mixed +5V (analog) and +3V (digital) supply voltages. They operate with a single +5V analog supply or dual  $\pm 5V$  analog supplies, and combine an 8-channel multiplexer, high-bandwidth track/hold, and serial interface with high conversion speed and low power consumption.

A 4-wire serial interface connects directly to SPI/MICROWIRE® devices without external logic, and a serial strobe output allows direct connection to TMS320-family digital signal processors. The MAX1202/MAX1203 use either the internal clock or an external serial-interface clock to perform successive approximation analog-to-digital conversions. The serial interface operates at up to 2MHz.

The MAX1202 features an internal 4.096V reference, while the MAX1203 requires an external reference. Both parts have a reference-buffer amplifier that simplifies gain trim. They also have a  $V_L$  pin that is the power supply for the digital outputs. Output logic levels (3V, 3.3V, or 5V) are determined by the value of the voltage applied to this pin.

These devices provide a hard-wired  $\overline{\text{SHDN}}$  pin and two software-selectable power-down modes. Accessing the serial interface automatically powers up the devices. A quick turn-on time enables the MAX1202/MAX1203 to be shut down between conversions, allowing the user to optimize supply currents. By customizing power-down between conversions, supply current can drop below 10 $\mu\text{A}$  at reduced sampling rates.

The MAX1202/MAX1203 are available in 20-pin SSOP and PDIP packages, and are specified for the commercial and extended temperature ranges.

### Applications

- 5V/3V Mixed-Supply Systems
- Data Acquisition
- High-Accuracy Process Control
- Battery-Powered Instruments
- Medical Instruments

**Typical Operating Circuit appears at end of data sheet.**

*MICROWIRE is a registered trademark of National Semiconductor Corp.*

### Features

- 8-Channel Single-Ended or 4-Channel Differential Inputs
- Operates from Single +5V or Dual  $\pm 5V$  Supplies
- User-Adjustable Output Logic Levels (2.7V to 5.25V)
- Low Power: 1.5mA (Operating Mode)  
2 $\mu\text{A}$  (Power-Down Mode)
- Internal Track/Hold, 133kHz Sampling Rate
- Internal 4.096V Reference (MAX1202)
- SPI/MICROWIRE/TMS320-Compatible 4-Wire Serial Interface
- Software-Configurable Unipolar/Bipolar Inputs
- 20-Pin PDIP/SSOP

### Ordering Information

PART	TEMP RANGE	PIN-PACKAGE	INL (LSB)
MAX1202ACPP+	0°C to +70°C	20 PDIP	$\pm 1/2$
MAX1202BCPP+	0°C to +70°C	20 PDIP	$\pm 1$
MAX1202ACAP+	0°C to +70°C	20 SSOP	$\pm 1/2$
MAX1202BCAP+	0°C to +70°C	20 SSOP	$\pm 1$

**Ordering Information continued at end of data sheet.**

+Denotes a lead(Pb)-free/RoHS-compliant package.

### Pin Configuration

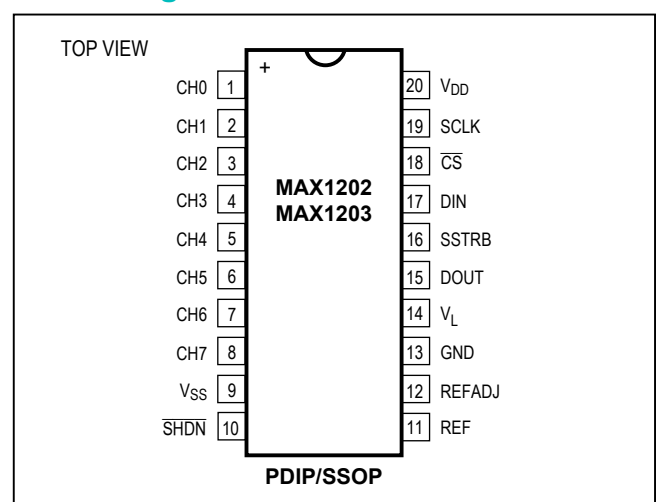

**Absolute Maximum Ratings**

V <sub>DD</sub> to GND .....	-0.3V to +6V	Continuous Power Dissipation (T <sub>A</sub> = +70°C)
V <sub>L</sub> .....	-0.3V to (V <sub>DD</sub> + 0.3V)	PDI (derate 11.11mW/°C above +70°C).....
V <sub>SS</sub> to GND.....	+0.3V to -6V	SSOP (derate 8.00mW/°C above +70°C).....
V <sub>DD</sub> to V <sub>SS</sub> .....	-0.3V to +12V	Operating Temperature Ranges
CH0–CH7 to GND.....	(V <sub>SS</sub> - 0.3V) to (V <sub>DD</sub> + 0.3V)	MAX1202_C_P/MAX1203_C_P.....
CH0–CH7 Total Input Current .....	±20mA	MAX1202_E_P/MAX1203_E_P.....
REF to GND .....	-0.3V to (V <sub>DD</sub> + 0.3V)	Storage Temperature Range.....
REFADJ to GND.....	-0.3V to (V <sub>DD</sub> + 0.3V)	Lead Temperature (soldering, 10s).....
Digital Inputs to GND .....	-0.3V to (V <sub>DD</sub> + 0.3V)	Soldering Temperature (reflow).....
Digital Outputs to GND.....	-0.3V to (V <sub>L</sub> + 0.3V)	
Digital Output Sink Current .....	25mA	

Stresses beyond those listed under "Absolute Maximum Ratings" may cause permanent damage to the device. These are stress ratings only, and functional operation of the device at these or any other conditions beyond those indicated in the operational sections of the specifications is not implied. Exposure to absolute maximum rating conditions for extended periods may affect device reliability.

**Electrical Characteristics**

(V<sub>DD</sub> = +5V ±5%, V<sub>L</sub> = 2.7V to 3.6V; V<sub>SS</sub> = 0V or -5V ±5%; f<sub>SCLK</sub> = 2.0MHz, external clock (50% duty cycle); 15 clocks/conversion cycle (133ksps); MAX1202—4.7µF capacitor at REF pin; MAX1203—external reference, V<sub>REF</sub> = 4.096V applied to REF pin; T<sub>A</sub> = T<sub>MIN</sub> to T<sub>MAX</sub>, unless otherwise noted.)

PARAMETER	SYMBOL	CONDITIONS	MIN	TYP	MAX	UNITS
<b>DC ACCURACY (Note 1)</b>						
Resolution	RES		12			Bits
Relative Accuracy (Note 2)	INL	MAX1202A/MAX1203A			±0.5	LSB
		MAX1202B/MAX1203B			±1.0	
Differential Nonlinearity	DNL	no missing codes over temperature			±1.0	LSB
Offset Error					±3.0	LSB
Gain Error (Note 3)		MAX1202 (all grades)			±3	LSB
		External reference, 4.096V	MAX1203A		±1.5	
			MAX1203B		±3	
Gain Temperature Coefficient		External reference, 4.096V		±0.8		ppm/°C
Channel-to-Channel Offset Matching				±0.1		LSB
<b>DYNAMIC SPECIFICATIONS (10kHz sine-wave input, 4.096V<sub>P-P</sub>, 133ksps, 2.0MHz external clock, bipolar-input mode)</b>						
Signal-to-Noise Plus Distortion Ratio	SINAD		70			dB
Total Harmonic Distortion (up to the 5th Harmonic)	THD				-80	dB
Spurious-Free Dynamic Range	SFDR		80			dB
Channel-to-Channel Crosstalk		V <sub>IN</sub> = 4.096V <sub>P-P</sub> , 65kHz (Note 4)		-85		dB
Small-Signal Bandwidth		-3dB rolloff		4.5		MHz
Full-Power Bandwidth				800		kHz

**Electrical Characteristics (continued)**

( $V_{DD} = +5V \pm 5\%$ ,  $V_L = 2.7V$  to  $3.6V$ ;  $V_{SS} = 0V$  or  $-5V \pm 5\%$ ;  $f_{SCLK} = 2.0MHz$ , external clock (50% duty cycle); 15 clocks/conversion cycle (133ksps); MAX1202— $4.7\mu F$  capacitor at REF pin; MAX1203—external reference,  $V_{REF} = 4.096V$  applied to REF pin;  $T_A = T_{MIN}$  to  $T_{MAX}$ , unless otherwise noted.)

PARAMETER	SYMBOL	CONDITIONS	MIN	TYP	MAX	UNITS
<b>CONVERSION RATE</b>						
Conversion Time (Note 5)	$t_{CONV}$	Internal clock	5.5		10	$\mu s$
		External clock, 2MHz, 12 clocks/conversion	6			
Track/Hold Acquisition Time	$t_{ACQ}$		1.5			$\mu s$
Aperture Delay				10		ns
Aperture Jitter				< 50		ps
Internal Clock Frequency				1.7		MHz
External Clock Frequency Range		External compensation mode, $4.7\mu F$	0.1		2.0	MHz
		Internal compensation mode (Note 6)	0.1		0.4	
		Used for data transfer only	0		2.0	
<b>ANALOG INPUT</b>						
Input Voltage Range, Single-Ended and Differential (Note 7)		Unipolar, $V_{SS} = 0V$			$V_{REF}$	V
		Bipolar, $V_{SS} = -5V$			$\pm V_{REF}/2$	
Multiplexer Leakage Current		On/off-leakage current, $V_{CH\_} = \pm 5V$		$\pm 0.01$	$\pm 1$	$\mu A$
Input Capacitance		(Note 6)		16		pF
<b>INTERNAL REFERENCE (MAX1202 only, reference-buffer enabled)</b>						
REF Output Voltage		$T_A = +25^\circ C$	4.076	4.096	4.116	V
REF Short-Circuit Current					30	mA
$V_{REF}$ Temperature Coefficient		MAX1202AC		$\pm 30$	$\pm 50$	ppm/ $^\circ C$
		MAX1202AE		$\pm 30$	$\pm 60$	
		MAX1202B		$\pm 30$		
Load Regulation (Note 8)		0 to 0.5mA output load		2.5		mV
Capacitive Bypass at REF		Internal compensation mode		0		$\mu F$
		External compensation mode		4.7		
Capacitive Bypass at REFADJ				0.01		$\mu F$
REFADJ Adjustment Range				$\pm 1.5$		%
<b>EXTERNAL REFERENCE AT REF (Reference buffer disabled, <math>V_{REF} = 4.096V</math>)</b>						
Input Voltage Range			2.50		$V_{DD} + 50mV$	V
Input Current				200	350	$\mu A$
Input Resistance			12	20		k $\Omega$
REF Input Current in Shutdown		$V_{SHDN} = 0V$		1.5	10	$\mu A$
REFADJ Buffer Disable Threshold			$V_{DD} - 50mV$			V

**Electrical Characteristics (continued)**

( $V_{DD} = +5V \pm 5\%$ ,  $V_L = 2.7V$  to  $3.6V$ ;  $V_{SS} = 0V$  or  $-5V \pm 5\%$ ;  $f_{SCLK} = 2.0MHz$ , external clock (50% duty cycle); 15 clocks/conversion cycle (133ksp/s); MAX1202— $4.7\mu F$  capacitor at REF pin; MAX1203—external reference,  $V_{REF} = 4.096V$  applied to REF pin;  $T_A = T_{MIN}$  to  $T_{MAX}$ , unless otherwise noted.)

PARAMETER	SYMBOL	CONDITIONS	MIN	TYP	MAX	UNITS
<b>EXTERNAL REFERENCE AT REFADJ</b>						
Capacitive Bypass at REF		Internal compensation mode	0			$\mu F$
		External compensation mode	4.7			
Reference-Buffer Gain		MAX1202	1.68			V/V
		MAX1203	1.64			
REFADJ Input Current		MAX1202			$\pm 50$	$\mu A$
		MAX1203			$\pm 5$	
<b>POWER REQUIREMENTS</b>						
Positive Supply Voltage	$V_{DD}$		5 $\pm 5\%$			V
Negative Supply Voltage	$V_{SS}$		0 or 5 $\pm 5\%$			V
Positive Supply Current	$I_{DD}$	Operating mode	1.5	2.5		mA
		Fast power-down (Note 9)	30	70		$\mu A$
		Full power-down (Note 9)	2	10		
Negative Supply Current	$I_{SS}$	Operating mode and fast power-down			50	$\mu A$
		Full power-down			10	
Logic Supply Voltage	$V_L$		2.70		5.25	V
Logic Supply Current (Notes 6, 10)	$I_L$	$V_L = V_{DD} = 5V$			10	$\mu A$
Positive Supply Rejection (Note 11)	PSR	$V_{DD} = 5V \pm 5\%$ ; external reference, 4.096V; full-scale input	$\pm 0.06$		$\pm 0.5$	mV
Negative Supply Rejection (Note 11)	PSR	$V_{SS} = -5V \pm 5\%$ ; external reference, 4.096V; full-scale input	$\pm 0.01$		$\pm 0.5$	mV
Logic Supply Rejection (Note 12)	PSR	External reference, 4.096V; full-scale input	$\pm 0.06$		$\pm 0.5$	mV

**Electrical Characteristics (continued)**

( $V_{DD} = +5V \pm 5\%$ ,  $V_L = 2.7V$  to  $3.6V$ ;  $V_{SS} = 0V$  or  $-5V \pm 5\%$ ;  $f_{SCLK} = 2.0MHz$ , external clock (50% duty cycle); 15 clocks/conversion cycle (133ksp/s); MAX1202— $4.7\mu F$  capacitor at REF pin; MAX1203—external reference,  $V_{REF} = 4.096V$  applied to REF pin;  $T_A = T_{MIN}$  to  $T_{MAX}$ , unless otherwise noted.)

PARAMETER	SYMBOL	CONDITIONS	MIN	TYP	MAX	UNITS
<b>DIGITAL INPUTS—DIN, SCLK, <math>\overline{CS}</math>, <math>\overline{SHDN}</math></b>						
DIN, SCLK, $\overline{CS}$ Input High Voltage	$V_{IH}$		2.0			V
DIN, SCLK, $\overline{CS}$ Input Low Voltage	$V_{IL}$				0.8	V
DIN, SCLK, $\overline{CS}$ Input Hysteresis	$V_{HYST}$			0.15		V
DIN, SCLK, $\overline{CS}$ Input Leakage	$I_{IN}$	$V_{IN} = 0V$ or $V_{DD}$			$\pm 1$	$\mu A$
DIN, SCLK, $\overline{CS}$ Input Capacitance	$C_{IN}$	(Note 6)			15	pF
$\overline{SHDN}$ Input High Voltage	$V_{SH}$		$V_{DD} - 0.5$			V
$\overline{SHDN}$ Input Mid Voltage	$V_{SM}$		1.5	$V_{DD} - 1.5$		V
$\overline{SHDN}$ Voltage, Unconnected	$V_{FLT}$	$\overline{SHDN} = \text{open}$		2.75		V
$\overline{SHDN}$ Input Low Voltage	$V_{SL}$				0.5	V
$\overline{SHDN}$ Input Current, High	$I_{SH}$	$\overline{SHDN} = V_{DD}$			4.0	$\mu A$
$\overline{SHDN}$ Input Current, Low	$I_{SL}$	$V_{\overline{SHDN}} = 0V$	-4.0			$\mu A$
$\overline{SHDN}$ Maximum Allowed Leakage, Mid-Input		$\overline{SHDN} = \text{open}$	-100		+100	nA
<b>DIGITAL OUTPUTS—DOUT, SSTR (<math>V_L = 2.7V</math> to <math>3.6V</math>)</b>						
Output Voltage Low	$V_{OL}$	$I_{SINK} = 3mA$			0.4	V
		$I_{SINK} = 6mA$			0.3	
Output Voltage High	$V_{OH}$	$I_{SOURCE} = 1mA$	$V_L - 0.5$			V
Three-State Leakage Current	$I_{LEAK}$	$\overline{CS} = V_L$			$\pm 10$	$\mu A$
Three-State Output Capacitance	$C_{OUT}$	$\overline{CS} = V_L$ (Note 6)			15	pF
<b>DIGITAL OUTPUTS—DOUT, SSTR (<math>V_L = 4.75V</math> to <math>5.25V</math>)</b>						
Output Voltage Low	$V_{OL}$	$I_{SINK} = 5mA$			0.4	V
		$I_{SINK} = 8mA$			0.3	
Output Voltage High	$V_{OH}$	$I_{SOURCE} = 1mA$	4			V
Three-State Leakage Current	$I_{LEAK}$	$V_{\overline{CS}} = 5V$			$\pm 10$	$\mu A$
Three-State Output Capacitance	$C_{OUT}$	$V_{\overline{CS}} = 5V$ (Note 6)			15	pF

**TIMING CHARACTERISTICS**(V<sub>DD</sub> = +5V ±5%, V<sub>L</sub> = 2.7V to 3.6V, V<sub>SS</sub> = 0V or -5V ±5%, T<sub>A</sub> = T<sub>MIN</sub> to T<sub>MAX</sub>, unless otherwise noted.)

PARAMETER	SYMBOL	CONDITIONS	MIN	TYP	MAX	UNITS
Acquisition Time	t <sub>ACQ</sub>		1.5			μs
DIN to SCLK Setup	t <sub>DS</sub>		100			ns
DIN to SCLK Hold	t <sub>DH</sub>				0	ns
SCLK Fall to Output Data Valid	t <sub>DO</sub>	C <sub>LOAD</sub> = 100pF	20		240	ns
$\overline{\text{CS}}$ Fall to Output Enable	t <sub>DV</sub>	C <sub>LOAD</sub> = 100pF			240	ns
$\overline{\text{CS}}$ Rise to Output Disable	t <sub>TR</sub>	C <sub>LOAD</sub> = 100pF			240	ns
$\overline{\text{CS}}$ to SCLK Rise Setup	t <sub>CSS</sub>		100			ns
$\overline{\text{CS}}$ to SCLK Rise Hold	t <sub>CSH</sub>		0			ns
SCLK Pulse Width High	t <sub>CH</sub>		200			ns
SCLK Pulse Width Low	t <sub>CL</sub>	C <sub>LOAD</sub> = 100pF	200			ns
SCLK Fall to SSTRB	t <sub>SSTRB</sub>				240	ns
$\overline{\text{CS}}$ Fall to SSTRB Output Enable (Note 6)	t <sub>SDV</sub>	External-clock mode only, C <sub>LOAD</sub> = 100pF			240	ns
$\overline{\text{CS}}$ Rise to SSTRB Output Disable (Note 6)	t <sub>STR</sub>				240	ns
SSTRB Rise to SCLK Rise (Note 6)	t <sub>SCK</sub>		0			ns

**Note 1:** Tested at V<sub>DD</sub> = 5.0V; V<sub>SS</sub> = 0V; unipolar-input mode.**Note 2:** Relative accuracy is the analog value's deviation (at any code) from its theoretical value after the full-scale range is calibrated.**Note 3:** MAX1202—internal reference, offset nulled; MAX1203—external reference (V<sub>REF</sub> = 4.096V), offset nulled.**Note 4:** On-channel grounded; sine wave applied to all off-channels.**Note 5:** Conversion time is defined as the number of clock cycles multiplied by the clock period; clock has 50% duty cycle.**Note 6:** Guaranteed by design. Not production tested.**Note 7:** Common-mode range for analog inputs is from V<sub>SS</sub> to V<sub>DD</sub>.**Note 8:** External load should not change during the conversion for specified accuracy.**Note 9:** Shutdown supply current is measured with V<sub>L</sub> at 3.3V, and with all digital inputs tied to either V<sub>L</sub> or GND; REFADJ = GND. Shutdown supply current is also dependent on V<sub>IH</sub> (Figure 12c).**Note 10:** Logic supply current is measured with the digital outputs (DOUT and SSTRB) disabled ( $\overline{\text{CS}}$  high). When the outputs are active ( $\overline{\text{CS}}$  low), the logic supply current depends on f<sub>SCLK</sub>, and on the static and capacitive load at DOUT and SSTRB.**Note 11:** Measured at V<sub>SUPPLY</sub> + 5% and V<sub>SUPPLY</sub> - 5% only.**Note 12:** Measured at V<sub>L</sub> = 2.7V and V<sub>L</sub> = 3.6V.

Typical Operating Characteristics

( $V_{DD} = 5V \pm 5\%$ ;  $V_L = 2.7V$  to  $3.6V$ ;  $V_{SS} = 0V$ ;  $f_{SCLK} = 2.0MHz$ , external clock (50% duty cycle); 15 clocks/conversion cycle (133ksp/s); MAX1202— $4.7\mu F$  capacitor at REF pin; MAX1203—external reference,  $V_{REF} = 4.096V$  applied to REF pin;  $T_A = +25^\circ C$ , unless otherwise noted.)

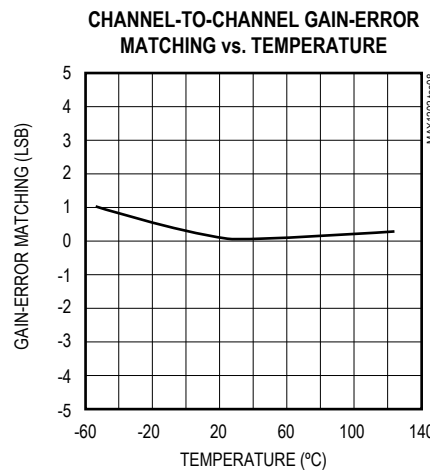
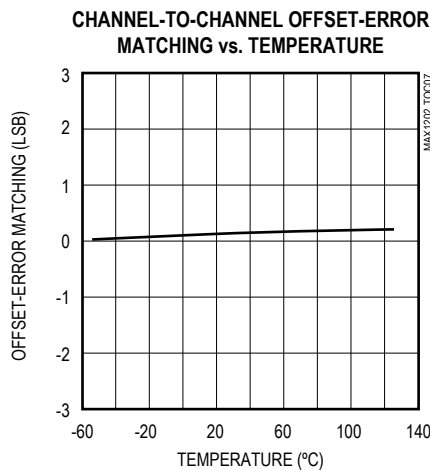
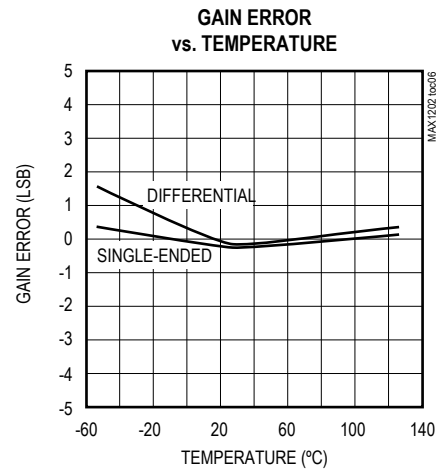
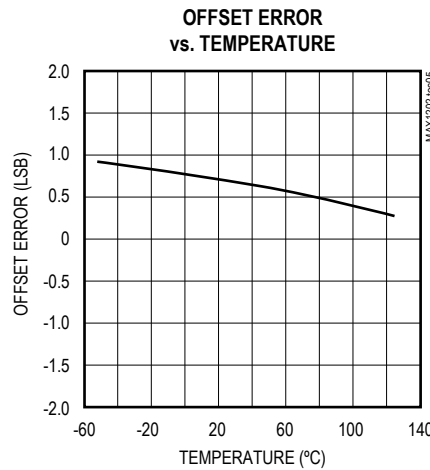
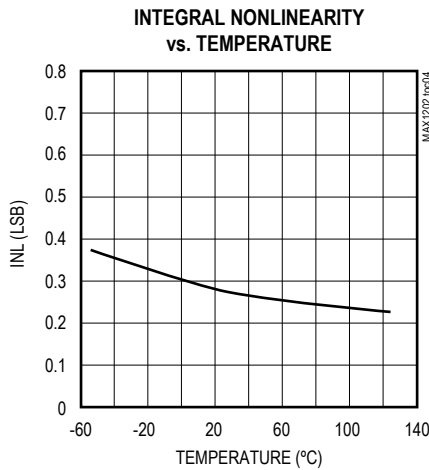
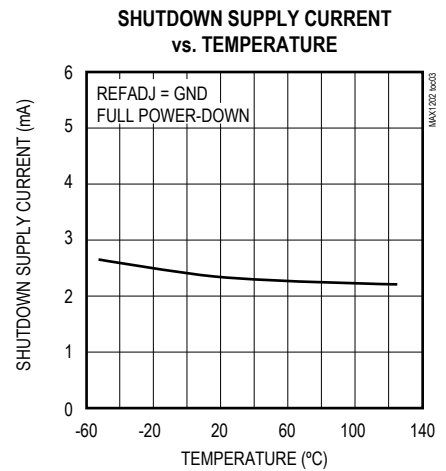
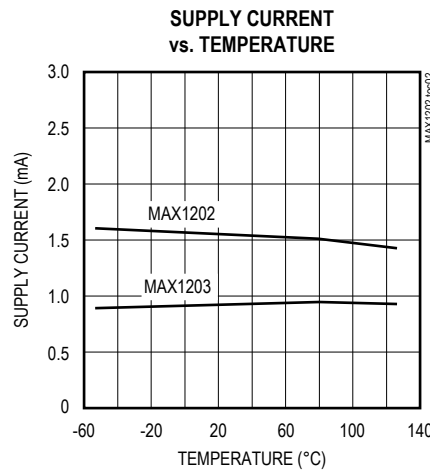
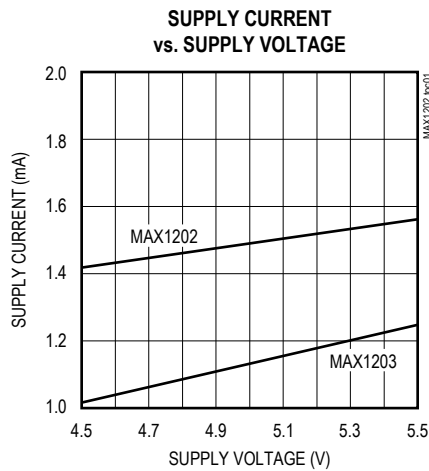

Typical Operating Characteristics (continued)

( $V_{DD} = 5V \pm 5\%$ ;  $V_L = 2.7V$  to  $3.6V$ ;  $V_{SS} = 0V$ ;  $f_{SCLK} = 2.0MHz$ , external clock (50% duty cycle); 15 clocks/conversion cycle (133ksp/s); MAX1202— $4.7\mu F$  capacitor at REF pin; MAX1203—external reference,  $V_{REF} = 4.096V$  applied to REF pin;  $T_A = +25^\circ C$ , unless otherwise noted.)

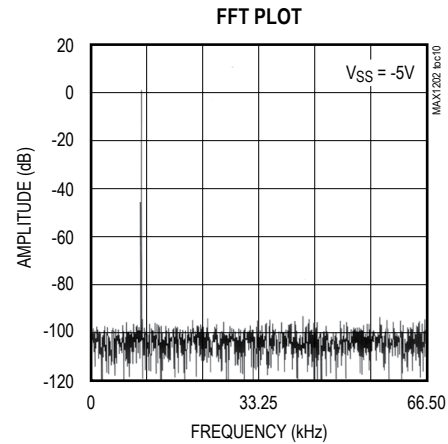
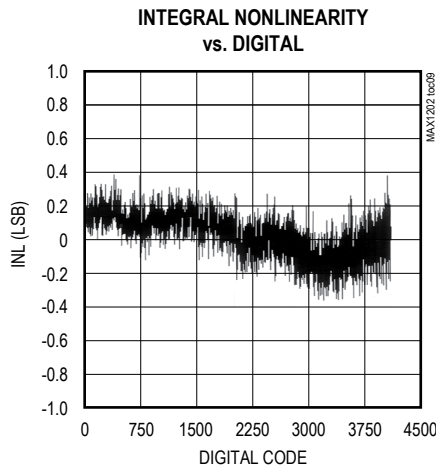

Pin Description

PIN	NAME	FUNCTION
1–8	CH0–CH7	Sampling Analog Inputs
9	$V_{SS}$	Negative Supply Voltage. Tie $V_{SS}$ to $-5V \pm 5\%$ or to GND.
10	$\overline{SHDN}$	Three-Level Shutdown Input. Pulling $\overline{SHDN}$ low shuts the MAX1202/MAX1203 down to $10\mu A$ (max) supply current; otherwise, the MAX1202/MAX1203 are fully operational. Pulling $\overline{SHDN}$ to $V_{DD}$ puts the reference-buffer amplifier in internal compensation mode. Leaving $\overline{SHDN}$ unconnected puts the reference-buffer amplifier in external compensation mode.
11	REF	Reference-Buffer Output/ADC Reference Input. In internal reference mode (MAX1202 only), the reference buffer provides a $4.096V$ nominal output, externally adjustable at REFADJ. In external reference mode, disable the internal buffer by pulling REFADJ to $V_{DD}$ .
12	REFADJ	Input to the Reference-Buffer Amplifier. Tie REFADJ to $V_{DD}$ to disable the reference-buffer amplifier.
13	GND	Ground; IN- Input for Single-Ended Conversions
14	$V_L$	Supply Voltage for Digital Output Pins. Voltage applied to $V_L$ determines the positive output swing of the Digital Outputs (DOUT, SSTRB). $2.7V \leq V_L \leq 5.25V$ .
15	DOUT	Serial-Data Output. Data is clocked out at SCLK's falling edge. High impedance when $\overline{CS}$ is high.
16	SSTRB	Serial-Strobe Output. In internal clock mode, SSTRB goes low when the MAX1202/MAX1203 begin the analog-to-digital conversion, and goes high when the conversion is finished. In external clock mode, SSTRB pulses high for one clock period before the MSB decision. High impedance when $\overline{CS}$ is high (external clock mode).
17	DIN	Serial-Data Input. Data is clocked in at SCLK's rising edge.
18	$\overline{CS}$	Active-Low Chip Select. Data is not clocked into DIN unless $\overline{CS}$ is low. When $\overline{CS}$ is high, DOUT is high impedance.
19	SCLK	Serial-Clock Input. SCLK clocks data in and out of the serial interface. In external clock mode, SCLK also sets the conversion speed (Duty cycle must be 40% to 60% in external clock mode).
20	$V_{DD}$	Positive Supply Voltage, $+5V \pm 5\%$

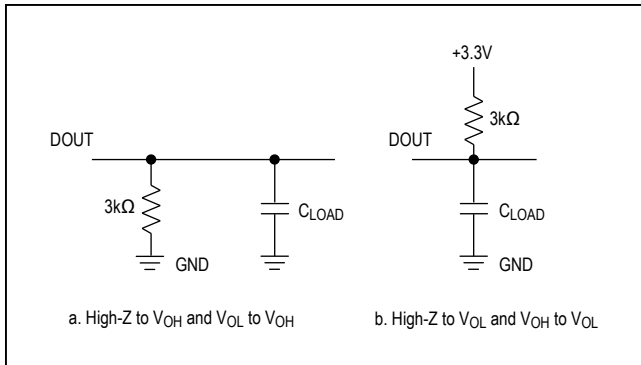

Figure 1. Load Circuits for Enable Time

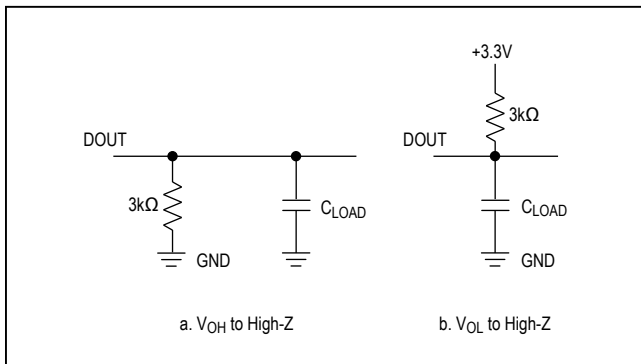

Figure 2. Load Circuits for Disable Time

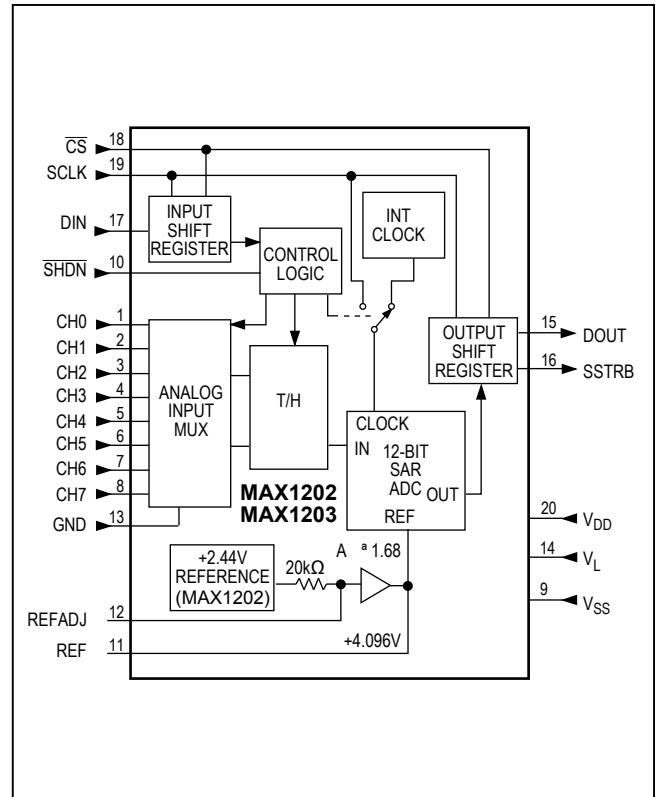

Figure 3. Block Diagram

### Detailed Description

The MAX1202/MAX1203 analog-to-digital converters (ADCs) use a successive-approximation conversion technique and input track/hold (T/H) circuitry to convert an analog signal to a 12-bit digital output. A flexible serial interface provides easy interface to 3V microprocessors ( $\mu$ Ps). Figure 3 is the MAX1202/MAX1203 block diagram.

### Pseudo-Differential Input

Figure 4 shows the ADC’s analog comparator’s sampling architecture. In single-ended mode,  $IN+$  is internally switched to  $CH0-CH7$  and  $IN-$  is switched to GND. In differential mode,  $IN+$  and  $IN-$  are selected from pairs of  $CH0/CH1$ ,  $CH2/CH3$ ,  $CH4/CH5$ , and  $CH6/CH7$ . Configure the channels using Tables 3 and 4.

In differential mode,  $IN-$  and  $IN+$  are internally switched to either of the analog inputs. This configuration is pseudo-differential such that only the signal at  $IN+$  is sampled. The return side ( $IN-$ ) must remain stable (typically within  $\pm 0.5$  LSB, within  $\pm 0.1$  LSB for best results) with respect

to GND during a conversion. To do this, connect a  $0.1\mu F$  capacitor from  $IN-$  (of the selected analog input) to GND.

During the acquisition interval, the channel selected as the positive input ( $IN+$ ) charges capacitor  $C_{HOLD}$ . The acquisition interval spans three SCLK cycles and ends on the falling SCLK edge after the input control word’s last bit is entered. The T/H switch opens at the end of the acquisition interval, retaining charge on  $C_{HOLD}$  as a sample of the signal at  $IN+$ .

The conversion interval begins with the input multiplexer switching  $C_{HOLD}$  from the positive input ( $IN+$ ) to the negative input ( $IN-$ ). In single-ended mode,  $IN-$  is simply GND. This unbalances node ZERO at the comparator’s input. The capacitive DAC adjusts during the remainder of the conversion cycle to restore node ZERO to 0V within the limits of 12-bit resolution. This action is equivalent to transferring a charge of  $16pF \times [(V_{IN+}) - (V_{IN-})]$  from  $C_{HOLD}$  to the binary-weighted capacitive DAC, which in turn forms a digital representation of the analog input signal.

**Track/Hold**

The T/H enters tracking mode on the falling clock edge after the fifth bit of the 8-bit control word is shifted in. The T/H enters hold mode on the falling clock edge after the eighth bit of the control word is shifted in. IN- is connected to GND if the converter is set up for single-ended inputs, and the converter samples the “+” input. IN- connects to the “-” input if the converter is set up for differential inputs, and the difference of |IN+ - IN-| is sampled. The positive input connects back to IN+, at the end of the conversion, and C<sub>HOLD</sub> charges to the input signal.

The time required for the T/H to acquire an input signal is a function of how quickly its input capacitance is charged. If the input signal’s source impedance is high, acquisition time increases and more time must be allowed between conversions. The acquisition time, t<sub>ACQ</sub>, is the maximum time the device takes to acquire the signal, and is also the minimum time needed for the signal to be acquired. It is calculated by the following:

$$t_{ACQ} = 9 \times (R_S + R_{IN}) \times 16\text{pF}$$

where R<sub>IN</sub> = 9kΩ, R<sub>S</sub> = the source impedance of the input signal, and t<sub>ACQ</sub> is never less than 1.5μs. Source impedances below 1kΩ do not significantly affect the ADC’s AC

performance. Higher source impedances can be used if an input capacitor is connected to the analog inputs, as shown in Figure 5. Note that the input capacitor forms an RC filter with the input source impedance, limiting the ADC’s signal bandwidth.

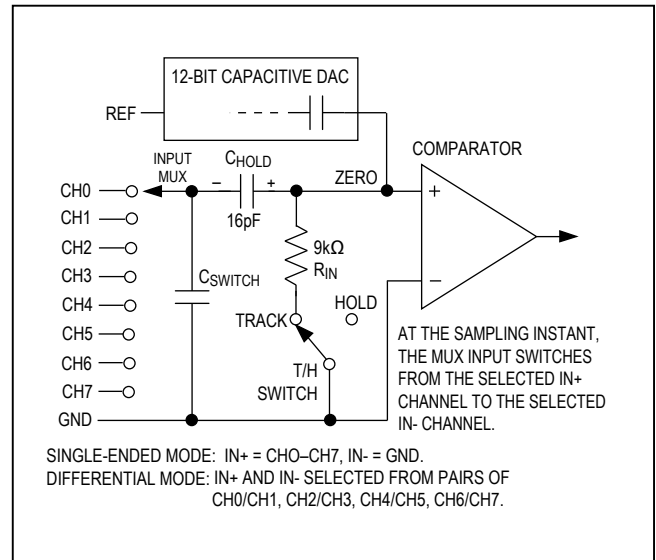

Figure 4. Equivalent Input Circuit

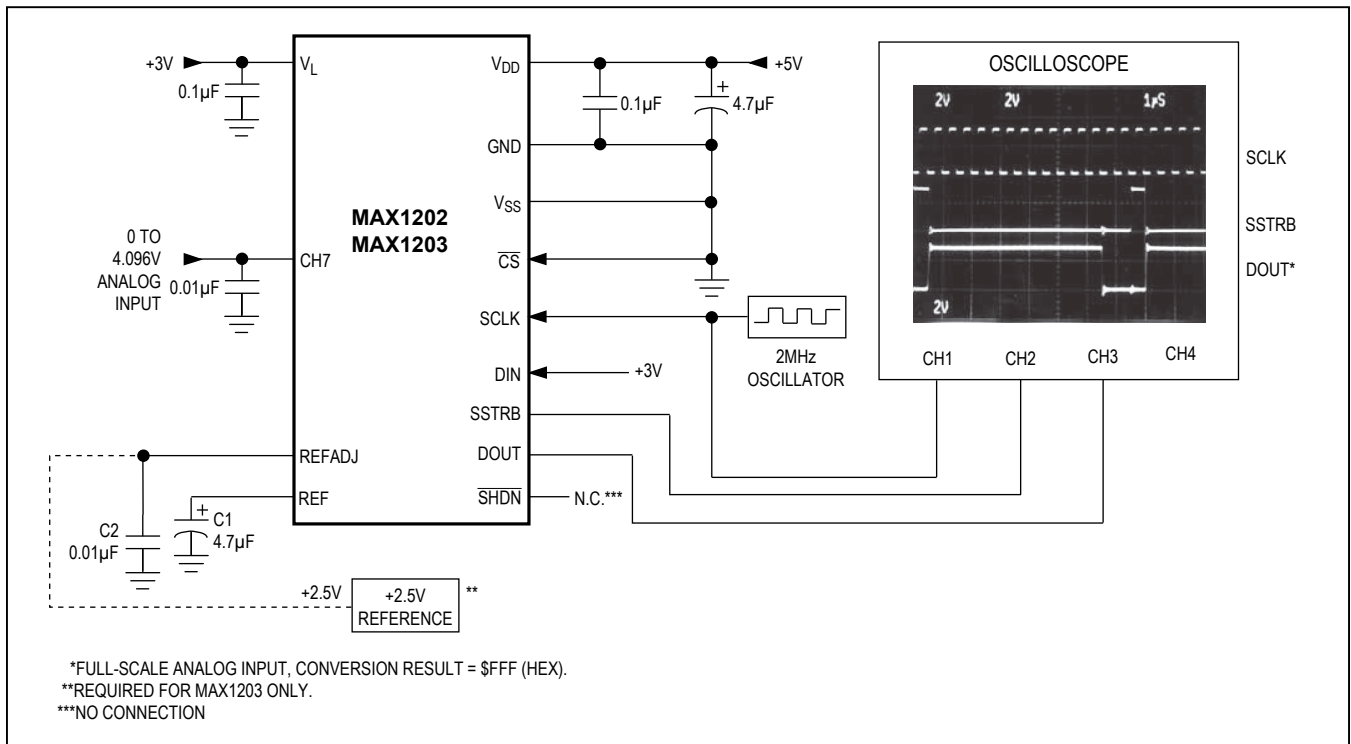

Figure 5. Quick-Look Circuit

**Table 1a. Unipolar Full Scale and Zero Scale**

REFERENCE		ZERO SCALE	FULL SCALE
Internal		0V	+4.096V
External	at REFADJ	0V	$V_{REFADJ} \times A^*$
	at REF	0V	$V_{REF}$

\*A = 1.68 for the MAX1202, 1.64 for the MAX1203.

**Input Bandwidth**

The ADC’s input tracking circuitry has a 4.5MHz small-signal bandwidth. Therefore it is possible to digitize high-speed transient events and measure periodic signals with bandwidths exceeding the ADC’s sampling rate by using undersampling techniques. To avoid high-frequency signals being aliased into the frequency band of interest, anti-alias filtering is recommended.

**Analog Input Range and Input Protection**

Internal protection diodes, which clamp the analog inputs to  $V_{DD}$  and  $V_{SS}$ , allow the analog input pins to swing from  $(V_{SS} - 0.3V)$  to  $(V_{DD} + 0.3V)$  without damage. However, for accurate conversions near full scale, the inputs must not exceed  $V_{DD}$  by more than 50mV, or be lower than  $V_{SS}$  by 50mV.

**If the analog input exceeds 50mV beyond the supplies, do not forward bias the protection diodes of off-channels more than 2mA.**

The full-scale input voltage depends on the voltage at REF (Tables 1a and 1b).

**Quick Look**

Use the circuit of Figure 5 to quickly evaluate the MAX1202/MAX1203’s analog performance. The MAX1202/MAX1203 require a control byte to be written to DIN before each conversion. Tying DIN to +3V feeds in control byte \$FF hex,

**Table 1b. Bipolar Full Scale, Zero Scale, and Negative Full Scale**

REFERENCE		NEGATIVE FULL SCALE	ZERO SCALE	FULL SCALE
Internal		+4.096V/2	0V	+4.096V/2
External	at REFADJ	$-1/2 V_{REFADJ} \times A^*$	0V	$+1/2 V_{REFADJ} \times A^*$
	at REF	$+1/2 V_{REF}$	0V	$+1/2 V_{REF}$

\*A = 1.68 for the MAX1202, 1.64 for the MAX1203.

which triggers single-ended unipolar conversions on CH7 in external clock mode without powering down between conversions. In external clock mode, the SSTRB output pulses high for one clock period before the most significant bit of the 12-bit conversion result shifts out of DOUT. Varying the analog input to CH7 alters the sequence of bits from DOUT. A total of 15 clock cycles per conversion is required. All SSTRB and DOUT output transitions occur on SCLK’s falling edge.

**How to Start a Conversion**

Clocking a control byte into DIN starts conversion on the MAX1202/MAX1203. With  $\overline{CS}$  low, each rising edge on SCLK clocks a bit from DIN into the MAX1202/MAX1203’s internal shift register. After  $\overline{CS}$  falls, the first logic “1” bit defines the control byte’s MSB. Until this first “start” bit arrives, any number of logic “0” bits can be clocked into DIN with no effect. Table 2 shows the control-byte format.

The MAX1202/MAX1203 are fully compatible with SPI/MICROWIRE devices. For SPI, select the correct clock polarity and sampling edge in the SPI control registers: set CPOL = 0 and CPHA = 0. MICROWIRE and SPI both transmit and receive a byte at the same time. Using the *Typical Operating Circuit*, the simplest software interface requires only three 8-bit transfers to perform a conversion (one 8-bit transfer to configure the ADC, and two more 8-bit transfers to clock out the 12-bit conversion result).

**Table 2. Control-Byte Format**

BIT 7 (MSB)	BIT 6	BIT 5	BIT 4	BIT 3	BIT 2	BIT 1	BIT 0 (LSB)															
START	SEL 2	SEL 1	SEL 0	UNI/BIP	SGL/DIF	PD1	PD0															
BIT	NAME	DESCRIPTION																				
7 (MSB)	START	The first logic 1 bit after $\overline{CS}$ goes low defines the beginning of the control byte.																				
6 5 4	SEL2 SEL1 SEL0	These three bits select which of the eight channels is used for the conversion (Tables 3 and 4).																				
3	UNI/BIP	1 = unipolar, 0 = bipolar. Selects unipolar or bipolar conversion mode. In unipolar mode, an analog input signal from 0 to $V_{REF}$ can be converted; in bipolar mode, the signal can range from $-V_{REF}/2$ to $+V_{REF}/2$ .																				
2	SGL/DIF	1 = single ended, 0 = differential. Selects single-ended or differential conversions. In single-ended mode, input signal voltages are referred to GND. In differential mode, the voltage difference between two channels is measured. (Tables 3 and 4).																				
1 0 (LSB)	PD1 PD0	Selects clock and power-down modes. <table border="1"> <thead> <tr> <th>PD1</th> <th>PD0</th> <th>Mode</th> </tr> </thead> <tbody> <tr> <td>0</td> <td>0</td> <td>Full power-down (<math>I_{DD} = 2\mu A</math>, internal reference)</td> </tr> <tr> <td>0</td> <td>1</td> <td>Fast power-down (<math>I_{DD} = 30\mu A</math>, internal reference)</td> </tr> <tr> <td>1</td> <td>0</td> <td>Internal clock mode</td> </tr> <tr> <td>1</td> <td>1</td> <td>External clock mode</td> </tr> </tbody> </table>						PD1	PD0	Mode	0	0	Full power-down ( $I_{DD} = 2\mu A$ , internal reference)	0	1	Fast power-down ( $I_{DD} = 30\mu A$ , internal reference)	1	0	Internal clock mode	1	1	External clock mode
PD1	PD0	Mode																				
0	0	Full power-down ( $I_{DD} = 2\mu A$ , internal reference)																				
0	1	Fast power-down ( $I_{DD} = 30\mu A$ , internal reference)																				
1	0	Internal clock mode																				
1	1	External clock mode																				

**Table 3. Channel Selection in Single-Ended Mode (SGL/DIF = 1)**

SEL2	SEL1	SEL0	CH0	CH1	CH2	CH3	CH4	CH5	CH6	CH7	GND
0	0	0	+								-
1	0	0		+							-
0	0	1			+						-
1	0	1				+					-
0	1	0					+				-
1	1	0						+			-
0	1	1							+		-
1	1	1								+	-

**Table 4. Channel Selection in Differential Mode (SGL/DIF = 0)**

SEL2	SEL1	SEL0	CH0	CH1	CH2	CH3	CH4	CH5	CH6	CH7
0	0	0	+	-						
0	0	1			+	-				
0	1	0					+	-		
0	1	1							+	-
1	0	0	-	+						
1	0	1			-	+				
1	1	0					-	+		
1	1	1							-	+

**Simple Software Interface**

Make sure the CPU's serial interface runs in master mode so the CPU generates the serial clock. Choose a clock frequency from 100kHz to 2MHz.

- 1) Set up the control byte for external clock mode and call it TB1. TB1's format should be: 1XXXXX11 binary, where the Xs denote the particular channel and conversion mode selected.
- 2) Use a general-purpose I/O line on the CPU to pull  $\overline{CS}$  on the MAX1202/MAX1203 low.
- 3) Transmit TB1 and simultaneously receive a byte and call it RB1. Ignore RB1.
- 4) Transmit a byte of all zeros (\$00 hex) and simultaneously receive byte RB2.
- 5) Transmit a byte of all zeros (\$00 hex) and simultaneously receive byte RB3.
- 6) Pull  $\overline{CS}$  on the MAX1202/MAX1203 high.

Figure 6 shows the timing for this sequence. Bytes RB2 and RB3 contain the result of the conversion padded with one leading zero and three trailing zeros. The total conversion time is a function of the serial-clock frequency and the amount of idle time between 8-bit transfers. To avoid excessive T/H droop, make sure that the total conversion time does not exceed 120µs.

**Digital Output**

In unipolar-input mode, the output is straight binary (Figure 15); for bipolar inputs, the output is two's complement (Figure 16). Data is clocked out at SCLK's falling edge in MSB-first format. The digital output logic level is adjusted with the  $V_L$  pin. This allows DOUT and SSTRB to interface with 3V logic without the risk of overdrive. The MAX1202/MAX1203's digital inputs are designed to be compatible with 5V CMOS logic as well as 3V logic.

**Internal and External Clock Modes**

The MAX1202/MAX1203 can use either an external serial clock or the internal clock to perform the successive-approximation conversion. In both clock modes, the external clock shifts data in and out of the MAX1202/MAX1203. The T/H acquires the input signal as the last three bits of the control byte are clocked into DIN. Bits PD1 and PD0 of the control byte program the clock mode. Figures 7–10 show the timing characteristics common to both modes.

**External Clock**

In external clock mode, the external clock not only shifts data in and out, but it also drives the A/D conversion steps. SSTRB pulses high for one clock period after the last bit of the control byte. Successive-approximation bit decisions are made and appear at DOUT on each of the next 12 SCLK falling edges (Figure 6). SSTRB and DOUT go into a high-impedance state when  $\overline{CS}$  goes high; after

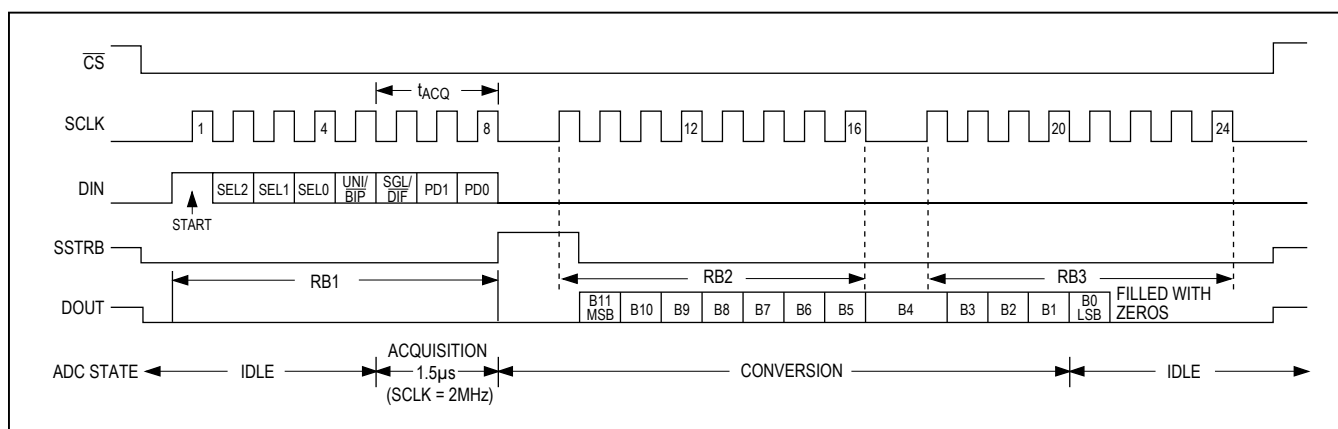

Figure 6. 24-Bit External Clock Mode Conversion Timing (MICROWIRE and SPI Compatible)

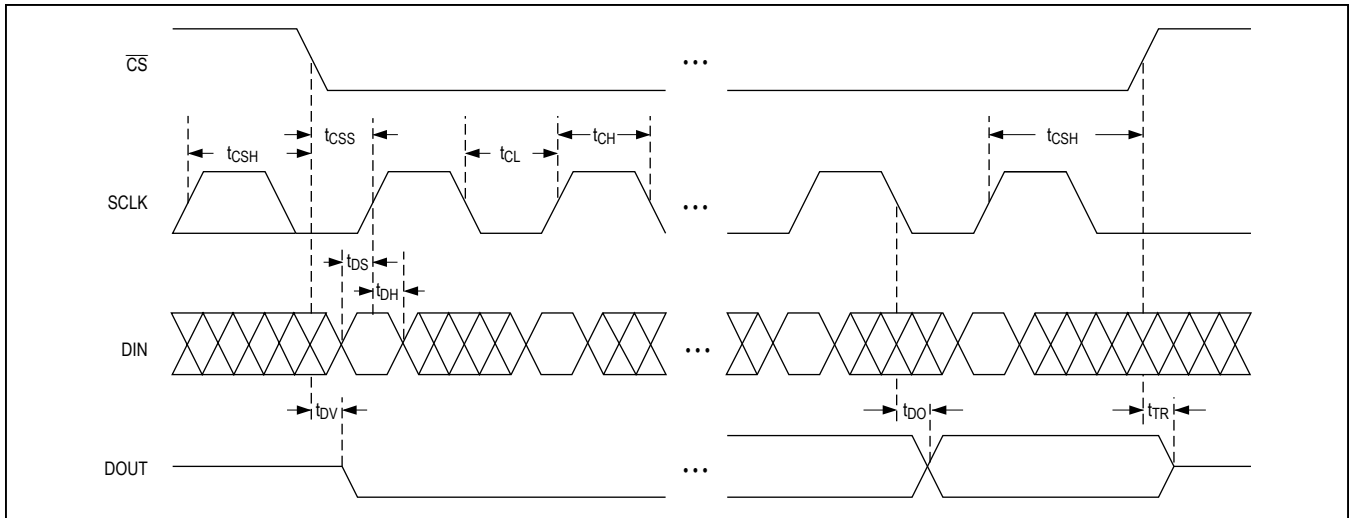

Figure 7. Detailed Serial-Interface Timing

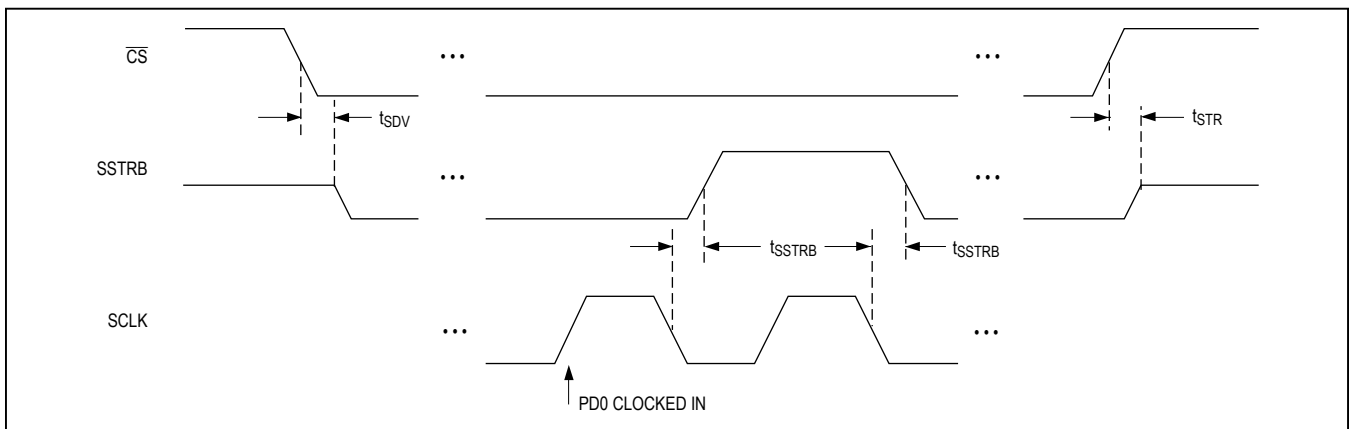

Figure 8. External Clock Mode SSTRB Detailed Timing

the next  $\overline{CS}$  falling edge, SSTRB outputs a logic low. Figure 8 shows SSTRB timing in external clock mode.

The conversion must complete in some minimum time or droop on the sample-and-hold capacitors might degrade conversion results. Use internal clock mode if the clock period exceeds 10 $\mu$ s or if serial-clock interruptions could cause the conversion interval to exceed 120 $\mu$ s.

**Internal Clock**

In internal clock mode, the MAX1202/MAX1203 generate their own conversion clock. This frees the  $\mu$ P from run-

ning the SAR conversion clock, and allows the conversion results to be read back at the processor's convenience, at any clock rate from zero to 2MHz. SSTRB goes low at the start of the conversion, then goes high when the conversion is complete. SSTRB is low for a maximum of 10 $\mu$ s, during which time SCLK should remain low for best noise performance. An internal register stores data while the conversion is in progress. SCLK clocks the data out at this register at any time after the conversion is complete. After SSTRB goes high, the next falling clock edge produces the MSB of the conversion at DOUT, fol-

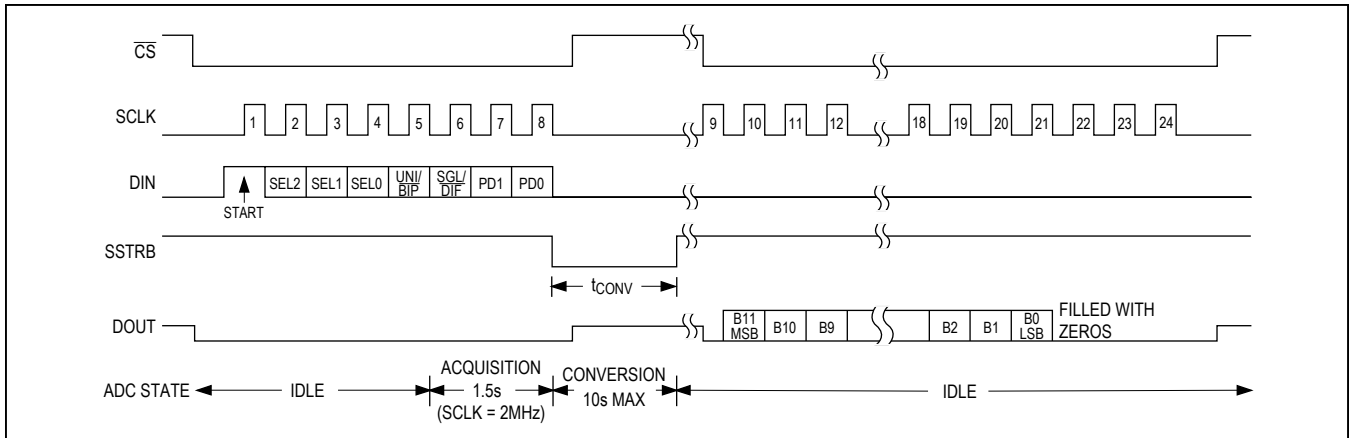

Figure 9. Internal Clock Mode Timing

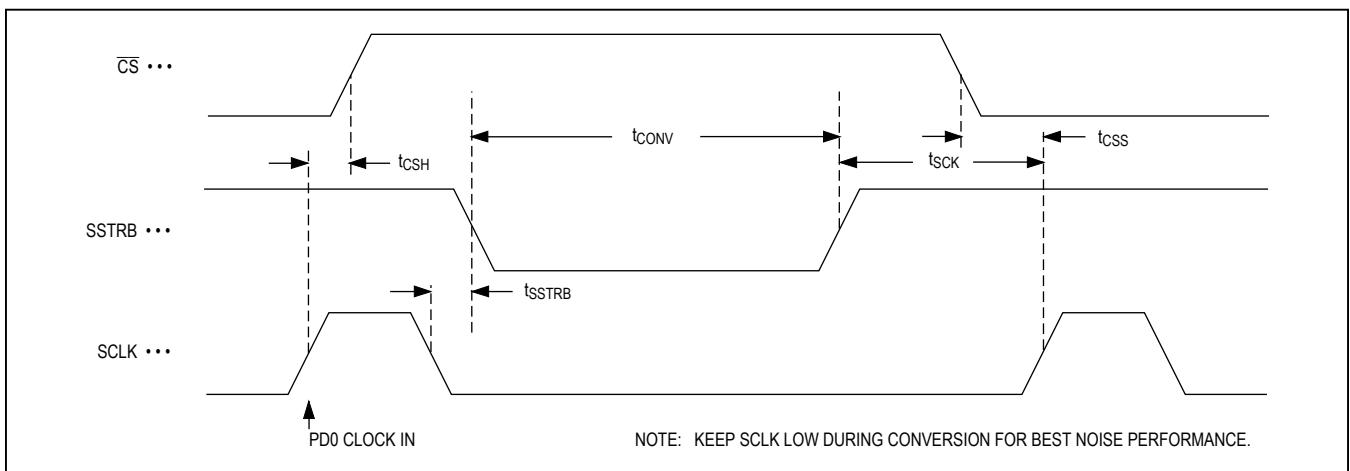

Figure 10. Internal Clock Mode SSTRB Detailed Timing

lowed by the remaining bits in MSB-first format (Figure 9).  $\overline{CS}$  does not need to be held low once a conversion is started. Pulling  $\overline{CS}$  high prevents data from being clocked into the MAX1202/MAX1203 and three-states DOUT, but it does not adversely affect an internal clock mode conversion already in progress. When internal clock mode is selected, SSTRB does not go into a high-impedance state when  $\overline{CS}$  goes high.

Figure 10 shows SSTRB timing in internal clock mode. Data can be shifted in and out of the MAX1202/MAX1203 at clock rates up to 2.0MHz, if  $t_{ACQ}$  is kept above 1.5 $\mu$ s.

**Data Framing**

$\overline{CS}$ 's falling edge does **not** start a conversion on the MAX1202/MAX1203. The first logic high clocked into

DIN is interpreted as a start bit and defines the first bit of the control byte. A conversion starts on SCLK's falling edge after the eighth bit of the control byte (the PD0 bit) is clocked into DIN. The start bit is defined as one of the following:

The first high bit clocked into DIN with  $\overline{CS}$  low anytime the converter is idle (e.g., after  $V_{DD}$  is applied).

or

The first high bit clocked into DIN after bit 5 (B5) of a conversion in progress appears at DOUT.

If a falling edge on  $\overline{CS}$  forces a start bit before B5 becomes available, the current conversion is terminated and a new one started. Thus, the fastest the MAX1202/MAX1203 can run is 15 clocks/conversion.

Figure 11a shows the serial-interface timing necessary to perform a conversion every 15 SCLK cycles in external clock mode. If  $\overline{CS}$  is low and SCLK is continuous, guarantee a start bit by first clocking in 16 zeros.

Most microcontrollers ( $\mu$ Cs) require that data transfers occur in multiples of eight clock cycles; 16 clocks per conversion is typically the fastest that a  $\mu$ C can drive the MAX1202/MAX1203. Figure 11b shows the serial-interface timing necessary to perform a conversion every 16 SCLK cycles in external clock mode.

## Applications Information

### Power-On Reset

When power is first applied and if  $\overline{SHDN}$  is not pulled low, internal power-on reset circuitry activates the MAX1202/MAX1203 in internal clock mode, ready to convert with SSTRB = high. After the power supplies are stabilized, the internal reset time is 100 $\mu$ s. No conversions should be performed during this phase. SSTRB is high on power-up, and if  $\overline{CS}$  is low, the first logical 1 on DIN is interpreted as a start bit. Until a conversion takes place, DOUT shifts out zeros.

### Reference-Buffer Compensation

In addition to its shutdown function,  $\overline{SHDN}$  also selects internal or external compensation. The compensation affects both power-up time and maximum conversion speed. Compensated or not, the minimum clock rate is 100kHz due to droop on the sample-and-hold.

Leave  $\overline{SHDN}$  unconnected to select external compensation. The *Typical Operating Circuit* uses a 4.7 $\mu$ F capacitor at REF. A value of 4.7 $\mu$ F or greater ensures stability and allows converter operation at the 2MHz full clock speed. External compensation increases power-up time (see the section *Choosing Power-Down Mode*, and Table 5).

Internal compensation requires no external capacitor at REF, and is selected by pulling  $\overline{SHDN}$  high. Internal compensation allows for the shortest power-up times, but the external clock must be limited to 400kHz during the conversion.

### Power-Down

#### Choosing Power-Down Mode

You can save power by placing the converter in a low-current shutdown state between conversions. Select full power-down or fast power-down mode via bits 1 and 0 of the DIN control byte with  $\overline{SHDN}$  high or unconnected (Tables 2 and 6). Pull  $\overline{SHDN}$  low at any time to shut down the converter completely.  $\overline{SHDN}$  overrides bits 1 and 0 of the control byte.

Full power-down mode turns off all chip functions that draw quiescent current, reducing  $I_{DD}$  and  $I_{SS}$  typically to 2 $\mu$ A.

For the MAX1202, fast power-down mode turns off all circuitry except the bandgap reference. With fast power-down mode, the supply current is 30 $\mu$ A. Power-up time can be shortened to 5 $\mu$ s in internal compensation mode. Since the MAX1203 does not have an internal reference, power-up times coming out of full or fast power-down are identical.

$I_{DD}$  shutdown current can increase if any digital input (DIN, SCLK,  $\overline{CS}$ ) is held high in either power-down mode. The actual shutdown current depends on the state of the digital inputs, the voltage applied to the digital inputs ( $V_{IH}$ ), the supply voltage ( $V_{DD}$ ), and the operating temperature. Figure 12c shows the maximum  $I_{DD}$  increase for each digital input held high in power-down mode for different operating conditions. This current is cumulative, so if all three digital inputs are held high, the additional shutdown current is three times the value shown in Figure 12c.

In both software power-down modes, the serial interface remains operational, but the ADC does not convert.

Table 5 shows how the choice of reference-buffer compensation and power-down mode affects both power-up delay and maximum sample rate. In external compensation mode, power-up time is 20ms with a 4.7 $\mu$ F compensation capacitor (200ms with a 33 $\mu$ F capacitor) when the capacitor is initially fully discharged. From fast power-down, start-up time can be eliminated by using low-leakage capacitors that do not discharge more than 1/2 LSB while shut down. In power-down, the capacitor has to supply the current into the reference (typically 1.5 $\mu$ A) and the transient currents at power-up.

Figures 12a and 12b show the various power-down sequences in both external and internal clock modes.

### Software Power-Down

Software power-down is activated using bits PD1 and PD0 of the control byte. As shown in Table 6, PD1 and PD0 also specify the clock mode. When software power-down is asserted, the ADC continues to operate in the last specified clock mode until the conversion is complete. The ADC then powers down into a low quiescent-current state. In internal clock mode, the interface remains active and conversion results can be clocked out even though the MAX1202/MAX1203 have already entered software power-down.

The first logical 1 on DIN is interpreted as a start bit and powers up the MAX1202/MAX1203. Following the start bit, the control byte also determines clock and power-

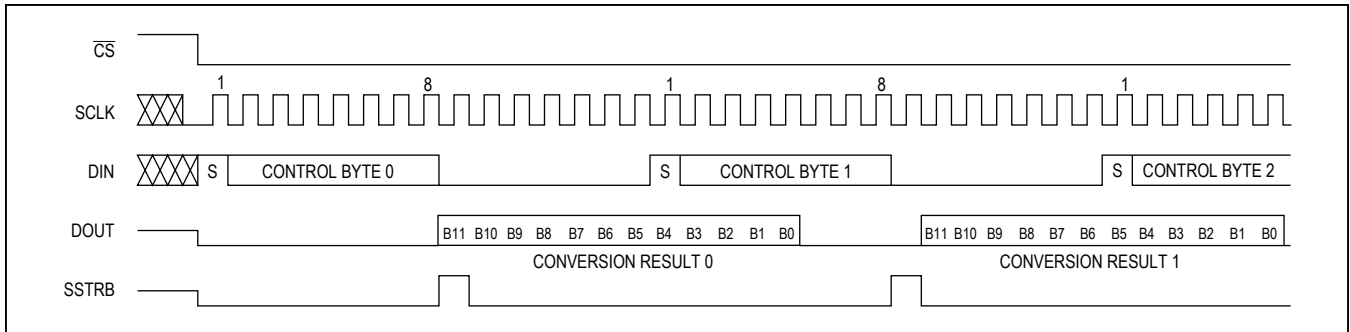

Figure 11a. External Clock Mode, 15 Clocks/Conversion Timing

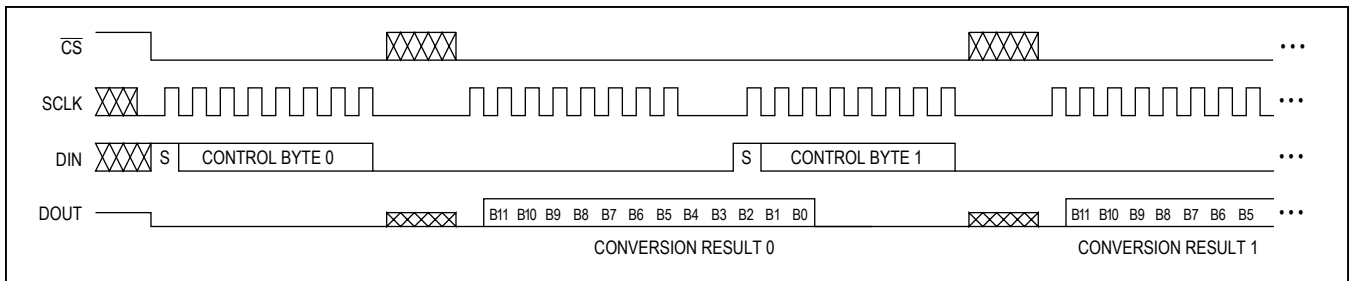

Figure 11b. External Clock Mode, 16 Clocks/Conversion Timing

down modes. For example, if the DIN word contains PD1 = 1, the chip remains powered up. If PD1 = 0, power-down resumes after one conversion.

**Hardware Power-Down**

The  $\overline{\text{SHDN}}$  pin places the converter into full power-down mode. Unlike the software power-down modes, conversion is not completed; it stops coincidentally with  $\overline{\text{SHDN}}$  being brought low. There is no power-up delay if an external reference, which is not shut down, is used.  $\overline{\text{SHDN}}$  also selects internal or external reference compensation (Table 7).

**Power-Down Sequencing**

The MAX1202/MAX1203's automatic power-down modes can save considerable power when operating at less than maximum sample rates. The following sections discuss the various power-down sequences.

**Lowest Power at up to 500 Conversions per Channel per Second**

Figure 14a depicts MAX1202 power consumption for one or eight channel conversions using full power-down mode and internal reference compensation. A 0.01 $\mu\text{F}$  bypass capacitor at REFADJ forms an RC filter with the internal 20k $\Omega$  reference resistor, with a 0.2ms time constant. To achieve full 12-bit accuracy, 10 time constants (or 2ms in

this example) are required for the reference buffer to settle. When exiting FULLPD, waiting this 2ms in FASTPD mode (instead of just exiting FULLPD mode and returning to normal operating mode) reduces power consumption by a factor of 10 or more (Figure 13).

**Lowest Power at Higher Throughputs**

Figure 14b shows power consumption with external reference compensation in fast power-down, with one and eight channels converted. The external 4.7 $\mu\text{F}$  compensation requires a 50 $\mu\text{s}$  wait after power-up. This circuit combines fast multichannel conversion with the lowest power consumption possible. Full power-down mode can increase power savings in applications where the MAX1202/MAX1203 are inactive for long periods of time, but where intermittent bursts of high-speed conversion are required.

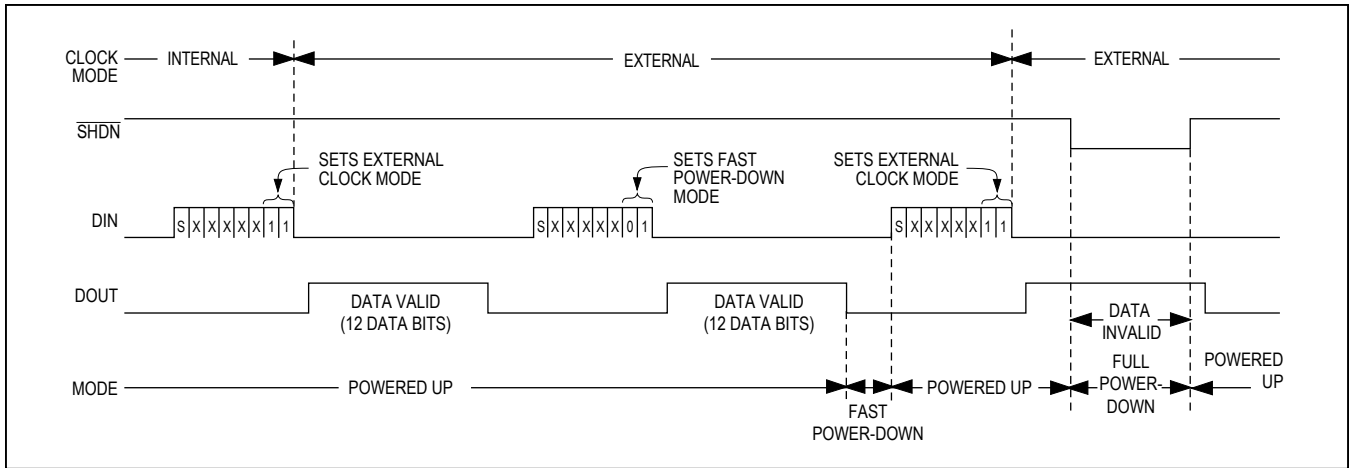

Figure 12a. Timing Diagram for Power-Down Modes, External Clock

Table 5. Typical Power-Up Delay Times

REFERENCE BUFFER	REFERENCE-BUFFER COMPENSATION MODE	REF CAPACITOR (μF)	POWER-DOWN MODE	POWER-UP DELAY (μs)	MAXIMUM SAMPLING RATE (ksps)
Enabled	Internal	—	Fast	5	26
Enabled	Internal	—	Full	300	26
Enabled	External	4.7	Fast/Full	See Figure 14c	133
Disabled	—	—	Fast	2	133
Disabled	—	—	Full	2	133

Table 6. Software Shutdown and Clock Mode

PD1	PD0	DEVICE MODE
0	0	Full power-down mode
0	1	Fast power-down mode
1	0	Internal clock mode
1	1	External clock mode

Table 7. Hard-Wired Shutdown and Compensation Mode

SHDN STATE	DEVICE MODE	REFERENCE-BUFFER COMPENSATION
V <sub>DD</sub>	Enabled	Internal compensation
Unconnected	Enabled	External compensation
GND	Full power-down	N/A

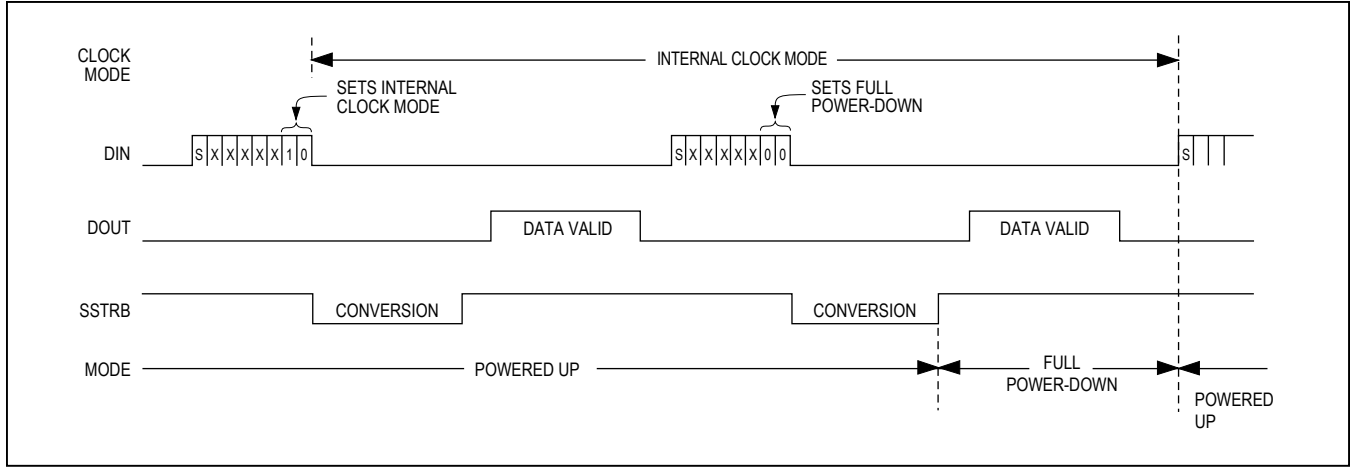

Figure 12b. Timing Diagram for Power-Down Modes, Internal Clock

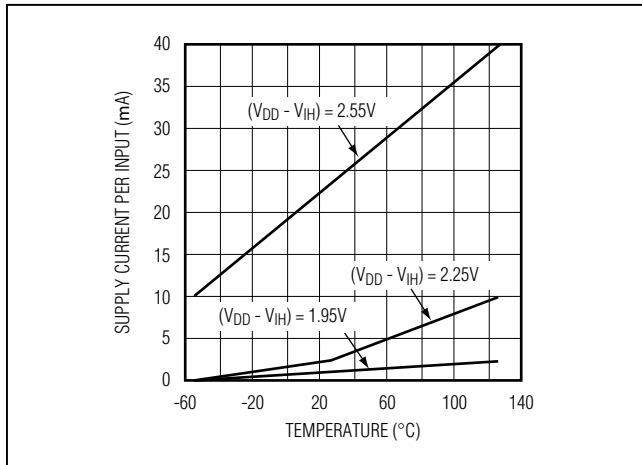

Figure 12c. Additional  $I_{DD}$  Shutdown Supply Current vs.  $V_{IH}$  for Each Digital Input at a Logic 1

**External and Internal References**

The MAX1202 can be used with an internal or external reference, whereas an external reference is required for the MAX1203. An external reference can be connected directly at the REF terminal, or at the REFADJ pin.

An internal buffer is designed to provide 4.096V at REF for both the MAX1202 and the MAX1203. The MAX1202's internally trimmed 2.44V reference is buffered with a gain of 1.68. The MAX1203's REFADJ pin is buffered with a gain of 1.64, to scale an external 2.5V reference at REFADJ to 4.096V at REF.

**MAX1202 Internal Reference**

The MAX1202's full-scale range using the internal reference is 4.096V with unipolar inputs and  $\pm 2.048V$  with bipolar inputs. The internal reference voltage is adjustable to  $\pm 1.5\%$  with the circuit of Figure 17.

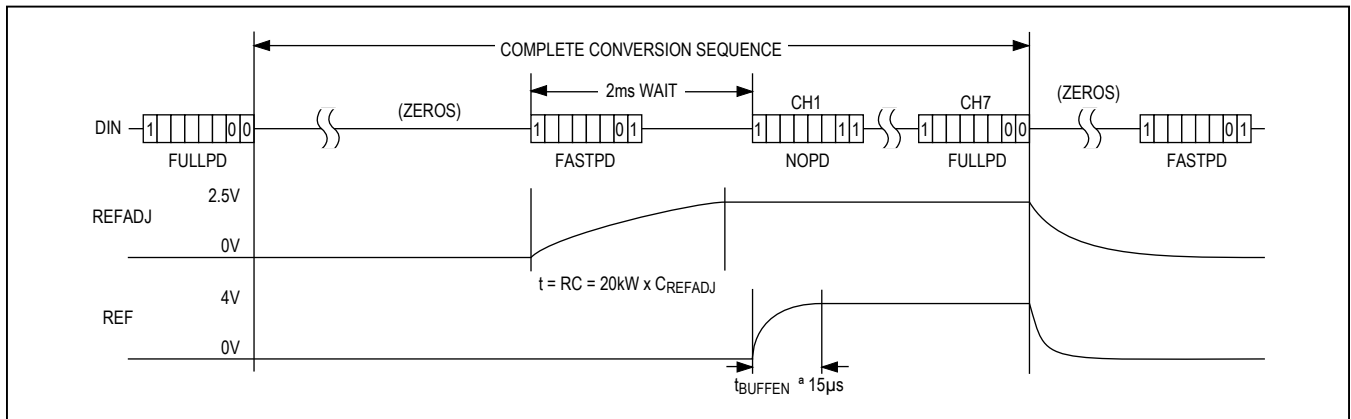

Figure 13. MAX1202 FULLPD/FASTPD Power-Up Sequence

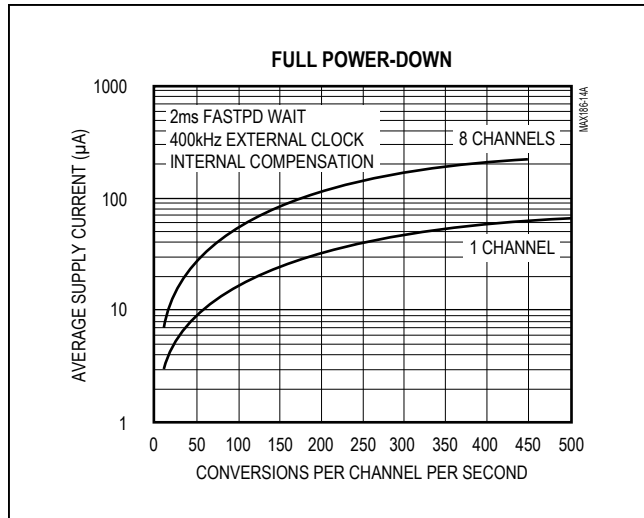

Figure 14a. MAX1202 Supply Current vs. Sample Rate/Second, FULLPD, 400kHz Clock

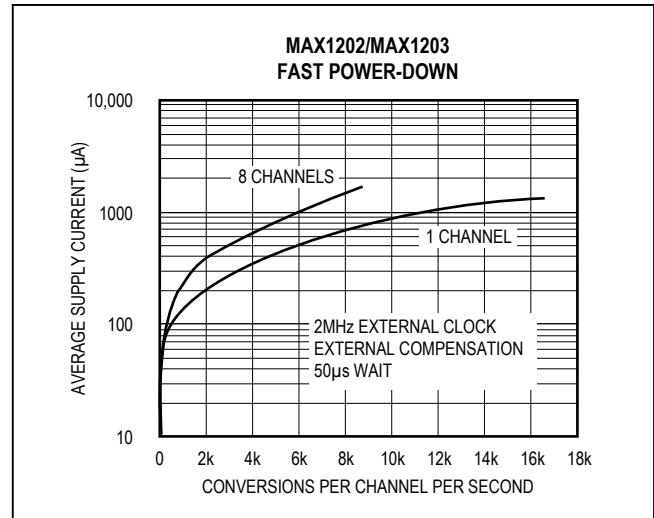

Figure 14b. MAX1202/MAX1203 Supply Current vs. Sample Rate/Second, FASTPD, 2MHz Clock

**External Reference**

With both the MAX1202 and MAX1203, an external reference can be placed at either the input (REFADJ) or the output (REF) of the internal reference-buffer amplifier. The REFADJ input impedance is typically 20kΩ for the MAX1202, and higher than 100kΩ for the MAX1203, where the internal reference is omitted. At REF, the DC input resistance is a minimum of 12kΩ. During conversion, an external reference at REF must deliver up to 350µA DC load current and have an output impedance of 10Ω or less. If the reference has higher output impedance or is noisy, bypass it close to the REF pin with a 4.7µF capacitor.

Using the buffered REFADJ input makes buffering of the external reference unnecessary. When connecting an external reference directly at REF, disable the internal buffer by tying REFADJ to V<sub>DD</sub>. In power-down, the input bias current to REFADJ can be as much as 25µA with REFADJ tied to V<sub>DD</sub> (MAX1202 only). Pull REFADJ to GND to minimize the input bias current in power-down.

**Transfer Function and Gain Adjust**

Figure 15 depicts the nominal, unipolar input/output (I/O) transfer function, and Figure 16 shows the bipolar I/O transfer function. Code transitions occur halfway between successive-integer LSB values. Output coding is binary with 1 LSB = 1.00mV (4.096V/4096) for unipolar operation, and 1 LSB = 1.00mV [(4.096V/2 - -4.096V/2)/4096] for bipolar operation.

Figure 17 shows how to adjust the ADC gain in applications that use the internal reference. The circuit provides ±1.5% (±65 LSBs) of gain adjustment range.

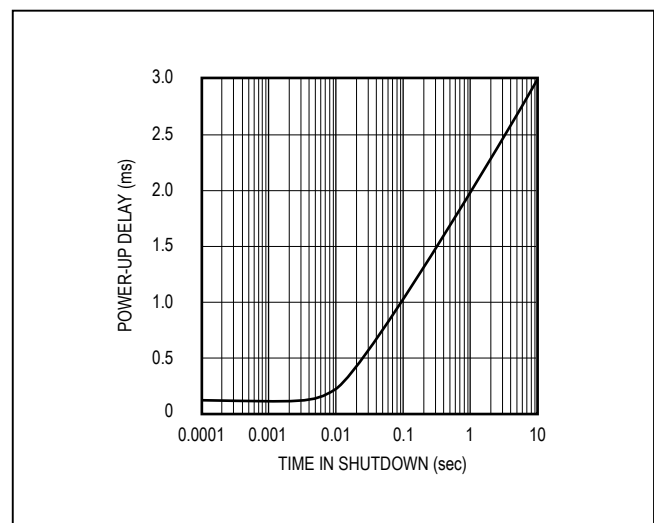

Figure 14c. Typical Power-Up Delay vs. Time in Shutdown

**Layout, Grounding, and Bypassing**

For best performance, use printed circuit boards. Wire-wrap boards are not recommended. Board layout should ensure that digital and analog signal lines are separated from each other. Do not run analog and digital (especially clock) lines parallel to one another, or digital lines underneath the ADC package.

Figure 18 shows the recommended system ground connections. Establish a single-point analog ground

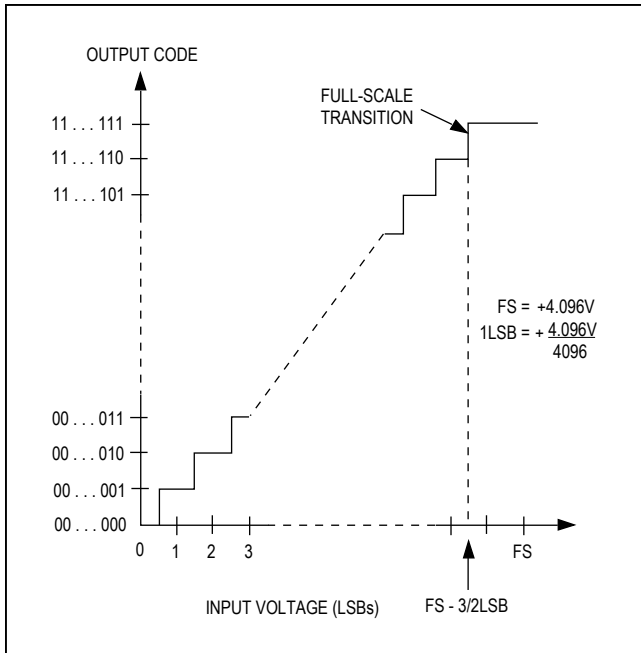

Figure 15. Unipolar Transfer Function, 4.096V = Full Scale

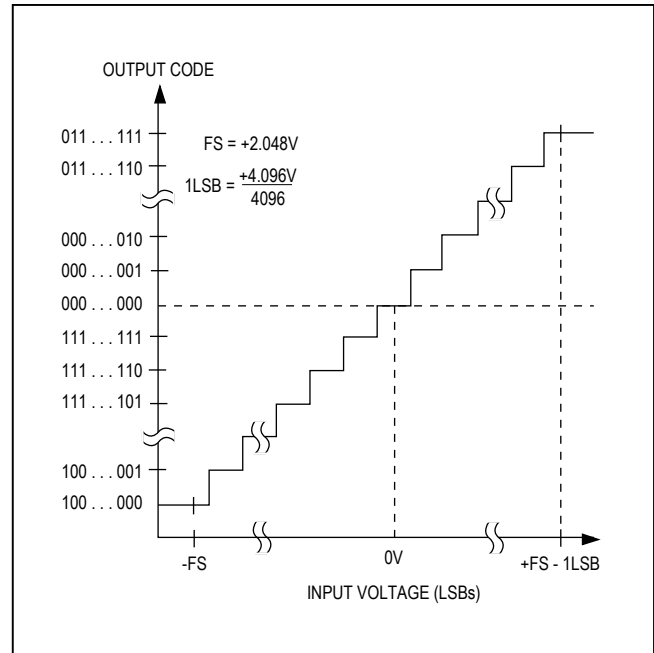

Figure 16. Bipolar Transfer Function, ±4.096V/2 = Full Scale

(“star” ground point) at GND. Connect all other analog grounds to this ground. No other digital system ground should be connected to this single-point analog ground. The ground return to the power supply for this ground should be low impedance and as short as possible for noise-free operation.

High-frequency noise in the power supplies can affect the ADC’s high-speed comparator. Bypass these supplies to the single-point analog ground with 0.1µF and 4.7µF bypass capacitors close to the MAX1202/MAX1203. Minimize capacitor lead lengths for best supply-noise rejection. If the +5V power supply is very noisy, a 10Ω resistor can be connected as a lowpass filter, as shown in Figure 18.

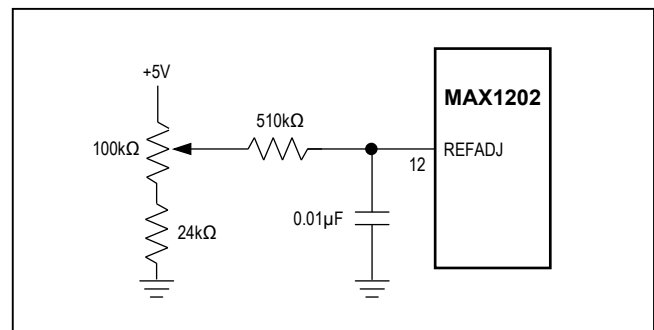

Figure 17. MAX1202 Reference-Adjust Circuit

**TMS320CL3x to MAX1202/ MAX1203 Interface**

Figure 19 shows an application circuit to interface the MAX1202/MAX1203 to the TMS320 in external clock mode. Figure 20 shows the timing diagram for this interface circuit.

Use the following steps to initiate a conversion in the MAX1202/MAX1203 and to read the results:

- 1) The TMS320 should be configured with CLKX (transmit clock) as an active-high output clock and CLKR (TMS320 receive clock) as an active-high input clock. The TMS320's CLKX and CLKR are tied together with the MAX1202/MAX1203's SCLK input.
- 2) The MAX1202/MAX1203's CS is driven low by the TMS320's XF\_ I/O port to enable data to be clocked into the MAX1202/MAX1203's DIN.
- 3) Write an 8-bit word (1XXXXX11) to the MAX1202/MAX1203 to initiate a conversion and place the device into external clock mode. Refer to Table 2 to select the proper XXXXX bit values for your specific application.
- 4) The MAX1202/MAX1203's SSTRB output is monitored via the TMS320's FSR input. A falling edge on the SSTRB output indicates that the conversion is in progress and data is ready to be received from the MAX1202/MAX1203.
- 5) The TMS320 reads in one data bit on each of the next 16 rising edges of SCLK. These data bits represent the 12-bit conversion result followed by four trailing bits, which should be ignored.
- 6) Pull CS high to disable the MAX1202/MAX1203 until the next conversion is initiated.

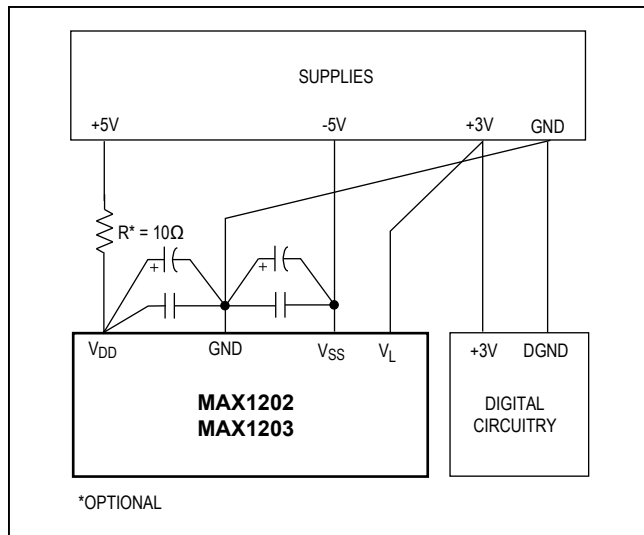

Figure 18. Power-Supply Grounding Connection

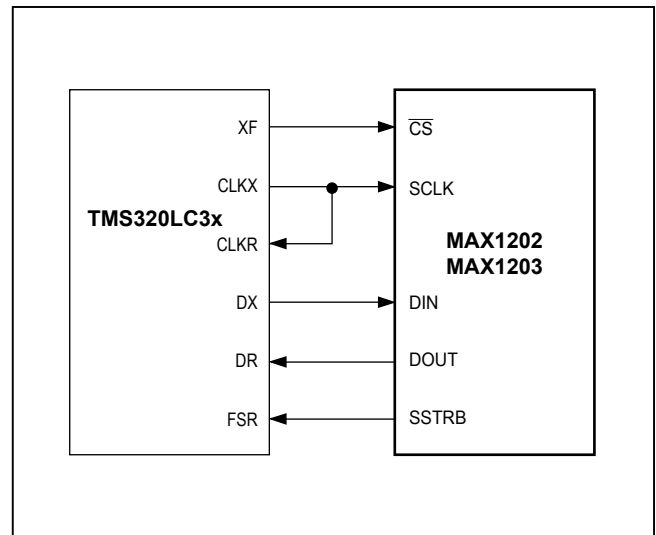

Figure 19. MAX1202/MAX1203-to-TMS320 Serial Interface

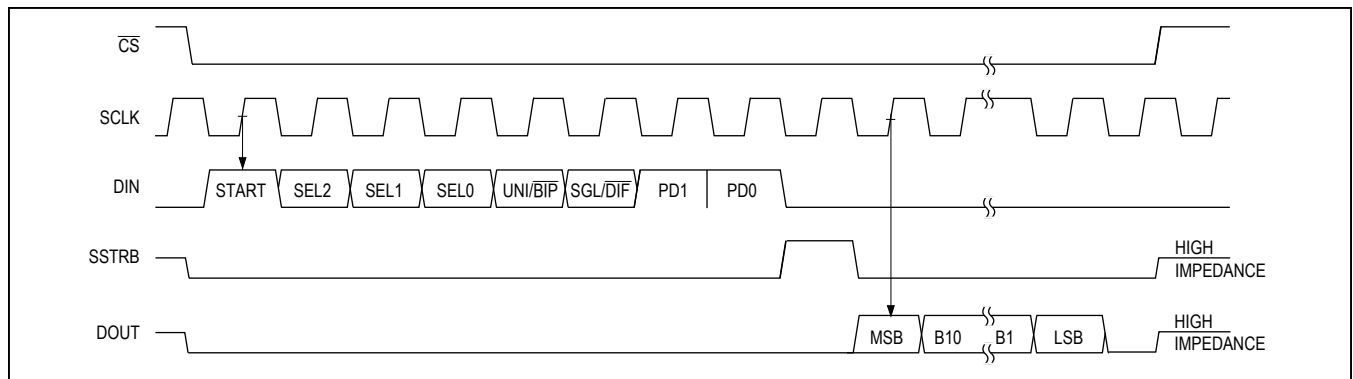

Figure 20. TMS320 Serial-Interface Timing Diagram

Ordering Information (continued)

PART	TEMP RANGE	PIN-PACKAGE	INL (LSB)
MAX1202AEPP+	-40°C to +85°C	20 PDIP	±1/2
MAX1202BEPP+	-40°C to +85°C	20 PDIP	±1
MAX1202AEAP+	-40°C to +85°C	20 SSOP	±1/2
MAX1202BEAP+	-40°C to +85°C	20 SSOP	±1
<b>MAX1203ACPP+</b>	0°C to +70°C	20 PDIP	±1/2
MAX1203BCPP+	0°C to +70°C	20 PDIP	±1
MAX1203ACAP+	0°C to +70°C	20 SSOP	±1/2
MAX1203BCAP+	0°C to +70°C	20 SSOP	±1
MAX1203AEPP+	-40°C to +85°C	20 PDIP	±1/2
MAX1203BEPP+	-40°C to +85°C	20 PDIP	±1
MAX1203AEAP+	-40°C to +85°C	20 SSOP	±1/2
MAX1203BEAP+	-40°C to +85°C	20 SSOP	±1

+Denotes a lead(Pb)-free/RoHS-compliant package.

Chip Information

PROCESS: BiCMOS

Package Information

For the latest package outline information and land patterns (footprints), go to [www.maximintegrated.com/packages](http://www.maximintegrated.com/packages). Note that a "+", "#", or "-" in the package code indicates RoHS status only. Package drawings may show a different suffix character, but the drawing pertains to the package regardless of RoHS status.

PACKAGE TYPE	PACKAGE CODE	DOCUMENT NO.	LAND PATTERN NO.
20 SSOP	A20+2	<a href="#">21-0056</a>	<a href="#">90-0094</a>
20 PDIP	P20+3	<a href="#">21-0043</a>	—

Typical Operating Circuit

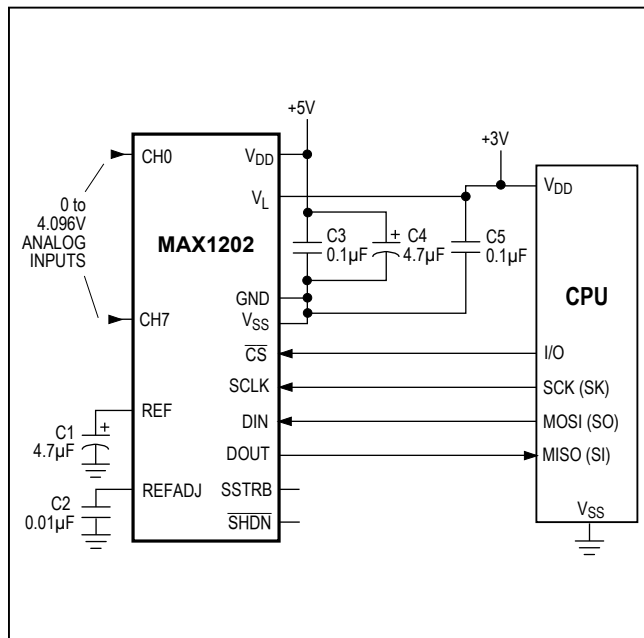

## Package Information

REVISION NUMBER	REVISION DATE	DESCRIPTION	PAGES CHANGED
0	1/97	Initial release	—
1	3/97	Added MAX1203 to the data sheet	1–24
2	5/98	Corrected gain error limit	2, 20
3	3/12	Removed military grade packages and updated style throughout data sheet	1–10, 13, 16, 18, 22, 23

For pricing, delivery, and ordering information, please contact Maxim Direct at 1-888-629-4642, or visit Maxim Integrated's website at [www.maximintegrated.com](http://www.maximintegrated.com).

*Maxim Integrated cannot assume responsibility for use of any circuitry other than circuitry entirely embodied in a Maxim Integrated product. No circuit patent licenses are implied. Maxim Integrated reserves the right to change the circuitry and specifications without notice at any time. The parametric values (min and max limits) shown in the Electrical Characteristics table are guaranteed. Other parametric values quoted in this data sheet are provided for guidance.*

## Looking for pricing, stock, or lifecycle information?

Click below to explore more details on WIN SOURCE:

- ⊖ [View MAX1202BCAP+T on WIN SOURCE](#)
- ⊖ [Maxim Integrated Information](#)

## Optimize Your Supply Chain with WIN SOURCE Solutions

- ✓ Global Sourcing Solution
- ✓ Obsolete Management
- ✓ Cost Control Management
- ✓ Shortage Management
- ✓ Alternative Solution
- ✓ Excess Inventory Management