



**THE DATASHEET OF
XCV405E-6BG560C**





Virtex™-E 1.8 V Extended Memory Field Programmable Gate Arrays

DS025-1 (v3.0) March 21, 2014

Production Product Specification

Features

- Fast, Extended Block RAM, 1.8 V FPGA Family
 - 560 Kb and 1,120 Kb embedded block RAM
 - 130 MHz internal performance (four LUT levels)
 - PCI compliant 3.3 V, 32/64-bit, 33/66-MHz
- Sophisticated SelectRAM+™ Memory Hierarchy
 - 294 Kb of internal configurable distributed RAM
 - Up to 1,120 Kb of synchronous internal block RAM
 - True Dual-Port block RAM
 - Memory bandwidth up to 2.24 Tb/s (equivalent bandwidth of over 100 RAMBUS channels)
 - Designed for high-performance Interfaces to external memories
 - 200 MHz ZBT* SRAMs
 - 200 Mb/s DDR SDRAMs
- Highly Flexible SelectIO+™ Technology
 - Supports 20 high-performance interface standards
 - Up to 556 singled-ended I/Os or up to 201 differential I/O pairs for an aggregate bandwidth of >100 Gb/s
- Complete Industry-Standard Differential Signalling Support
 - LVDS (622 Mb/s), BLVDS (Bus LVDS), LVPECL
 - All I/O signals can be input, output, or bi-directional
- LVPECL and LVDS clock inputs for 300+ MHz clocks
- Proprietary High-Performance SelectLink™ Technology
 - 80 Gb/s chip-to-chip communication link
 - Support for Double Data Rate (DDR) interface
 - Web-based HDL generation methodology
- Eight Fully Digital Delay-Locked Loops (DLLs)
- IEEE 1149.1 boundary-scan logic
- Supported by Xilinx Foundation Series™ and Alliance Series™ Development Systems
 - Internet Team Design (Xilinx iTD™) tool ideal for million-plus gate density designs
 - Wide selection of PC or workstation platforms
- SRAM-based In-System Configuration
 - Unlimited re-programmability
- Advanced Packaging Options
 - 1.0 mm FG676 and FG900
 - 1.27 mm BG560
- 0.18 μm 6-layer Metal Process with Copper Interconnect
- 100% Factory Tested

* ZBT is a trademark of Integrated Device Technology, Inc.

Introduction

The Virtex™-E Extended Memory (Virtex-EM) family of FPGAs is an extension of the highly successful Virtex-E family architecture. The Virtex-EM family (devices shown in [Table 1](#)) includes all of the features of Virtex-E, plus additional block RAM, useful for applications such as network switches and high-performance video graphic systems.

Xilinx developed the Virtex-EM product family to enable customers to design systems requiring high memory bandwidth, such as 160 Gb/s network switches. Unlike traditional ASIC devices, this family also supports fast time-to-market delivery, because the development engineering is already completed. Just complete the design and program the device. There is no NRE, no silicon production cycles, and no additional delays for design re-work. In addition, designers can update the design over a network at any time, providing product upgrades or updates to customers even sooner.

The Virtex-EM family is the result of more than fifteen years of FPGA design experience. Xilinx has a history of support-

ing customer applications by providing the highest level of logic, RAM, and features available in the industry. The Virtex-EM family, first FPGAs to deploy copper interconnect, offers the performance and high memory bandwidth for advanced system integration without the initial investment, long development cycles, and inventory risk expected in traditional ASIC development.

Table 1: Virtex-E Extended Memory Field-Programmable Gate Array Family Members

Device	Logic Gates	CLB Array	Logic Cells	Differential I/O Pairs	User I/O	BlockRAM Bits	Distributed RAM Bits
XCV405E	129,600	40 x 60	10,800	183	404	573,440	153,600
XCV812E	254,016	56 x 84	21,168	201	556	1,146,880	301,056

Virtex-E Compared to Virtex Devices

The Virtex-E family offers up to 43,200 logic cells in devices up to 30% faster than the Virtex family.

I/O performance is increased to 622 Mb/s using Source Synchronous data transmission architectures and synchronous system performance up to 240 MHz using singled-ended SelectI/O technology. Additional I/O standards are supported, notably LVPECL, LVDS, and BLVDS, which use two pins per signal. Almost all signal pins can be used for these new standards.

Virtex-E devices have up to 640 Kb of faster (250MHz) block SelectRAM, but the individual RAMs are the same size and structure as in the Virtex family. They also have eight DLLs instead of the four in Virtex devices. Each individual DLL is slightly improved with easier clock mirroring and 4x frequency multiplication.

V_{CCINT} , the supply voltage for the internal logic and memory, is 1.8 V, instead of 2.5 V for Virtex devices. Advanced processing and 0.18 μ m design rules have resulted in smaller dice, faster speed, and lower power consumption.

I/O pins are 3 V tolerant, and can be 5 V tolerant with an external 100 Ω resistor. PCI 5 V is not supported. With the addition of appropriate external resistors, any pin can tolerate any voltage desired.

Banking rules are different. With Virtex devices, all input buffers are powered by V_{CCINT} . With Virtex-E devices, the LVTTTL, LVCMOS2, and PCI input buffers are powered by the I/O supply voltage V_{CCO} .

The Virtex-E family is not bitstream-compatible with the Virtex family, but Virtex designs can be compiled into equivalent Virtex-E devices.

The same device in the same package for the Virtex-E and Virtex families are pin-compatible with some minor exceptions. See the data sheet pinout section for details.

General Description

The Virtex-E FPGA family delivers high-performance, high-capacity programmable logic solutions. Dramatic increases in silicon efficiency result from optimizing the new architecture for place-and-route efficiency and exploiting an aggressive 6-layer metal 0.18 μ m CMOS process. These advances make Virtex-E FPGAs powerful and flexible alter-

natives to mask-programmed gate arrays. The Virtex-E family includes the nine members in Table 1.

Building on experience gained from Virtex FPGAs, the Virtex-E family is an evolutionary step forward in programmable logic design. Combining a wide variety of programmable system features, a rich hierarchy of fast, flexible interconnect resources, and advanced process technology, the Virtex-E family delivers a high-speed and high-capacity programmable logic solution that enhances design flexibility while reducing time-to-market.

Virtex-E Architecture

Virtex-E devices feature a flexible, regular architecture that comprises an array of configurable logic blocks (CLBs) surrounded by programmable input/output blocks (IOBs), all interconnected by a rich hierarchy of fast, versatile routing resources. The abundance of routing resources permits the Virtex-E family to accommodate even the largest and most complex designs.

Virtex-E FPGAs are SRAM-based, and are customized by loading configuration data into internal memory cells. Configuration data can be read from an external SPROM (master serial mode), or can be written into the FPGA (SelectMAP™, slave serial, and JTAG modes).

The standard Xilinx Foundation Series™ and Alliance Series™ Development systems deliver complete design support for Virtex-E, covering every aspect from behavioral and schematic entry, through simulation, automatic design translation and implementation, to the creation and downloading of a configuration bit stream.

Higher Performance

Virtex-E devices provide better performance than previous generations of FPGAs. Designs can achieve synchronous system clock rates up to 240 MHz including I/O or 622 Mb/s using Source Synchronous data transmission architectures. Virtex-E I/Os comply fully with 3.3 V PCI specifications, and interfaces can be implemented that operate at 33 MHz or 66 MHz.

While performance is design-dependent, many designs operate internally at speeds in excess of 133 MHz and can achieve over 311 MHz. Table 2, page 3, shows performance data for representative circuits, using worst-case timing parameters.

Table 2: Performance for Common Circuit Functions

Function	Bits	Virtex-E -7
Register-to-Register		
Adder	16	4.3 ns
	64	6.3 ns
Pipelined Multiplier	8 x 8	4.4 ns
	16 x 16	5.1 ns
Address Decoder	16	3.8 ns
	64	5.5 ns
16:1 Multiplexer		4.6 ns
Parity Tree	9	3.5 ns
	18	4.3 ns
	36	5.9 ns
Chip-to-Chip		
HSTL Class IV		
LVTTTL, 16mA, fast slew		
LVDS		
LVPECL		

Virtex-E Extended Memory Device/Package Combinations and Maximum I/O

Table 3: Virtex-EM Family Maximum User I/O by Device/Package (Excluding Dedicated Clock Pins)

Package	XCV405E	XCV812E
BG560	404	404
FG676	404	
FG900		556

Virtex-E Extended Memory Ordering Information

Example: XCV405E-6BG560C

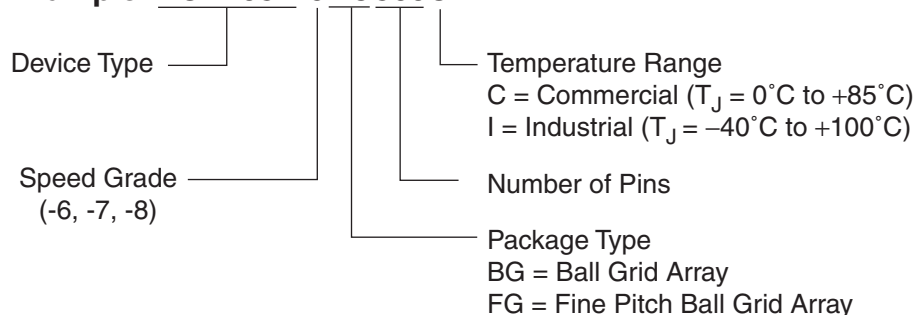

DS025_001_112000

Figure 1: Virtex Ordering Information

Revision History

The following table shows the revision history for this document.

Date	Version	Revision
03/23/2000	1.0	Initial Xilinx release.
08/01/2000	1.1	Accumulated edits and fixes. Upgrade to Preliminary. Preview -8 numbers added. Reformatted to adhere to corporate documentation style guidelines. Minor changes in BG560 pin-out table.
09/19/2000	1.2	<ul style="list-style-type: none"> In Table 3 (Module 4), FG676 Fine-Pitch BGA — XCV405E, the following pins are no longer labeled as VREF: B7, G16, G26, W26, AF20, AF8, Y1, H1. Min values added to Virtex-E Electrical Characteristics tables.
11/20/2000	1.3	<ul style="list-style-type: none"> Updated speed grade -8 numbers in Virtex-E Electrical Characteristics tables (Module 3). Updated minimums in Table 11 (Module 2), and added notes to Table 12 (Module 2). Added to note 2 of Absolute Maximum Ratings (Module 3). Changed all minimum hold times to -0.4 for Global Clock Set-Up and Hold for LVTTL Standard, with DLL (Module 3). Revised maximum T_{DLLPW} in -6 speed grade for DLL Timing Parameters (Module 3).
04/02/2001	1.4	<ul style="list-style-type: none"> In Table 4, FG676 Fine-Pitch BGA — XCV405E, pin B19 is no longer labeled as VREF, and pin G16 is now labeled as VREF. Updated values in Virtex-E Switching Characteristics tables. Converted data sheet to modularized format. See Virtex-E Extended Memory Data Sheet, below.
07/17/2002	1.5	<ul style="list-style-type: none"> Data sheet designation upgraded from Preliminary to Production.
03/21/2014	3.0	<ul style="list-style-type: none"> This product is obsolete/discontinued per XCN12026.

Virtex-E Extended Memory Data Sheet

The Virtex-E Extended Memory Data Sheet contains the following modules:

- DS025-1, Virtex-E 1.8V Extended Memory FPGAs: Introduction and Ordering Information (Module 1)
- DS025-2, Virtex-E 1.8V Extended Memory FPGAs: Functional Description (Module 2)
- DS025-3, Virtex-E 1.8V Extended Memory FPGAs: DC and Switching Characteristics (Module 3)
- DS025-4, Virtex-E 1.8V Extended Memory FPGAs: Pinout Tables (Module 4)



Virtex™-E 1.8 V Extended Memory Field Programmable Gate Arrays

DS025-2 (v3.0) March 21, 2014

Production Product Specification

Architectural Description

Virtex-E Array

The Virtex-E user-programmable gate array (see **Figure 1**) comprises two major configurable elements: configurable logic blocks (CLBs) and input/output blocks (IOBs).

- CLBs provide the functional elements for constructing logic.
- IOBs provide the interface between the package pins and the CLBs.

CLBs interconnect through a general routing matrix (GRM). The GRM comprises an array of routing switches located at the intersections of horizontal and vertical routing channels. Each CLB nests into a VersaBlock™ that also provides local routing resources to connect the CLB to the GRM.

The VersaRing™ I/O interface provides additional routing resources around the periphery of the device. This routing improves I/O routability and facilitates pin locking.

The Virtex-E architecture also includes the following circuits that connect to the GRM:

- Dedicated block memories of 4096 bits each
- Clock DLLs for clock-distribution delay compensation and clock domain control
- 3-State buffers (BUFTs) associated with each CLB that drive dedicated segmentable horizontal routing resources

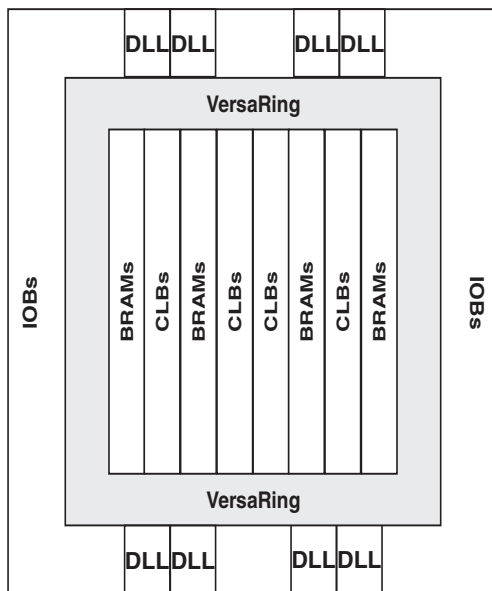

Figure 1: Virtex-E Architecture Overview

Values stored in static memory cells control the configurable logic elements and interconnect resources. These values load into the memory cells on power-up, and can reload if necessary to change the function of the device.

Input/Output Block

The Virtex-E IOB, **Figure 2**, features SelectIO+™ inputs and outputs that support a wide variety of I/O signalling standards (see **Table 1**).

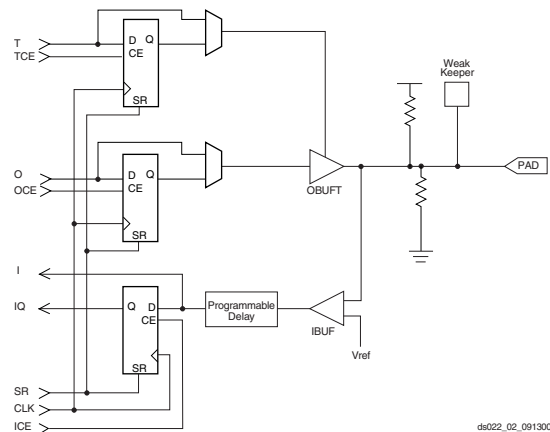

Figure 2: Virtex-E Input/Output Block (IOB)

The three IOB storage elements function either as edge-triggered D-type flip-flops or as level-sensitive latches. Each IOB has a clock signal (CLK) shared by the three flip-flops and independent clock enable signals for each flip-flop.

Table 1: Supported I/O Standards

I/O Standard	Output V _{CCO}	Input V _{CCO}	Input V _{REF}	Board Termination Voltage (V _{TT})
LVTTL	3.3	3.3	N/A	N/A
LVC MOS2	2.5	2.5	N/A	N/A
LVC MOS18	1.8	1.8	N/A	N/A
SSTL3 I & II	3.3	N/A	1.50	1.50
SSTL2 I & II	2.5	N/A	1.25	1.25
GTL	N/A	N/A	0.80	1.20
GTL+	N/A	N/A	1.0	1.50
HSTL I	1.5	N/A	0.75	0.75
HSTL III & IV	1.5	N/A	0.90	1.50
CTT	3.3	N/A	1.50	1.50
AGP-2X	3.3	N/A	1.32	N/A
PCI33_3	3.3	3.3	N/A	N/A
PCI66_3	3.3	3.3	N/A	N/A
BLVDS & LVDS	2.5	N/A	N/A	N/A
LVPECL	3.3	N/A	N/A	N/A

In addition to the CLK and CE control signals, the three flip-flops share a Set/Reset (SR). For each flip-flop, this signal can be independently configured as a synchronous Set, a synchronous Reset, an asynchronous Preset, or an asynchronous Clear.

The output buffer and all of the IOB control signals have independent polarity controls.

All pads are protected against damage from electrostatic discharge (ESD) and from over-voltage transients. After configuration, clamping diodes are connected to V_{CCO} with the exception of LVC MOS18, LVC MOS25, GTL, GTL+, LVDS, and LVPECL.

Optional pull-up, pull-down and weak-keeper circuits are attached to each pad. Prior to configuration all outputs not involved in configuration are forced into their high-impedance state. The pull-down resistors and the weak-keeper circuits are inactive, but IOs can optionally be pulled up.

The activation of pull-up resistors prior to configuration is controlled on a global basis by the configuration mode pins. If the pull-up resistors are not activated, all the pins are in a high-impedance state. Consequently, external pull-up or pull-down resistors must be provided on pins required to be at a well-defined logic level prior to configuration.

All Virtex-E IOBs support IEEE 1149.1-compatible boundary scan testing.

Input Path

The Virtex-E IOB input path routes the input signal directly to internal logic and/ or through an optional input flip-flop.

An optional delay element at the D-input of this flip-flop eliminates pad-to-pad hold time. The delay is matched to the internal clock-distribution delay of the FPGA, and when used, assures that the pad-to-pad hold time is zero.

Each input buffer can be configured to conform to any of the low-voltage signalling standards supported. In some of these standards the input buffer utilizes a user-supplied threshold voltage, V_{REF}. The need to supply V_{REF} imposes constraints on which standards can be used in close proximity to each other. See "I/O Banking" on page 2.

There are optional pull-up and pull-down resistors at each user I/O input for use after configuration. Their value is in the range 50 - 100 kΩ.

Output Path

The output path includes a 3-state output buffer that drives the output signal onto the pad. The output signal can be routed to the buffer directly from the internal logic or through an optional IOB output flip-flop.

The 3-state control of the output can also be routed directly from the internal logic or through a flip-flop that provides synchronous enable and disable.

Each output driver can be individually programmed for a wide range of low-voltage signalling standards. Each output buffer can source up to 24 mA and sink up to 48 mA. Drive strength and slew rate controls minimize bus transients.

In most signalling standards, the output High voltage depends on an externally supplied V_{CCO} voltage. The need to supply V_{CCO} imposes constraints on which standards can be used in close proximity to each other. See "I/O Banking" on page 2.

An optional weak-keeper circuit is connected to each output. When selected, the circuit monitors the voltage on the pad and weakly drives the pin High or Low to match the input signal. If the pin is connected to a multiple-source signal, the weak keeper holds the signal in its last state if all drivers are disabled. Maintaining a valid logic level in this way eliminates bus chatter.

Since the weak-keeper circuit uses the IOB input buffer to monitor the input level, an appropriate V_{REF} voltage must be provided if the signalling standard requires one. The provision of this voltage must comply with the I/O banking rules.

I/O Banking

Some of the I/O standards described above require V_{CCO} and/or V_{REF} voltages. These voltages are externally supplied and connected to device pins that serve groups of

I/Os, called banks. Consequently, restrictions exist about which I/O standards can be combined within a given bank.

Eight I/O banks result from separating each edge of the FPGA into two banks, as shown in Figure 3. Each bank has multiple V_{CCO} pins, all of which must be connected to the same voltage. This voltage is determined by the output standards in use.

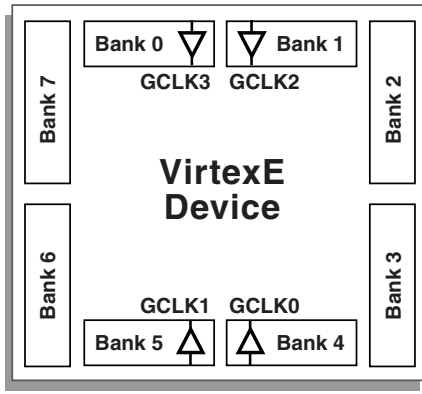

ds022_03_121799

Figure 3: Virtex-E I/O Banks

Within a bank, output standards can be mixed only if they use the same V_{CCO} . Compatible standards are shown in Table 2. GTL and GTL+ appear under all voltages because their open-drain outputs do not depend on V_{CCO} .

Table 2: Compatible Output Standards

V_{CCO}	Compatible Standards
3.3 V	PCI, LVTTTL, SSTL3 I, SSTL3 II, CTT, AGP, GTL, GTL+, LVPECL
2.5 V	SSTL2 I, SSTL2 II, LVCMOS2, GTL, GTL+, BLVDS, LVDS
1.8 V	LVCMOS18, GTL, GTL+
1.5 V	HSTL I, HSTL III, HSTL IV, GTL, GTL+

Some input standards require a user-supplied threshold voltage, V_{REF} . In this case, certain user-I/O pins are automatically configured as inputs for the V_{REF} voltage. Approximately one in six of the I/O pins in the bank assume this role.

The V_{REF} pins within a bank are interconnected internally and consequently only one V_{REF} voltage can be used within each bank. All V_{REF} pins in the bank, however, must be connected to the external voltage source for correct operation.

Within a bank, inputs that require V_{REF} can be mixed with those that do not. However, only one V_{REF} voltage can be used within a bank.

In Virtex-E, input buffers with LVTTTL, LVCMOS2, LVCMOS18, PCI33_3, PCI66_3 standards are supplied by V_{CCO} rather than V_{CCINT} . For these standards, only input and output buffers that have the same V_{CCO} can be mixed together.

The V_{CCO} and V_{REF} pins for each bank appear in the device pin-out tables and diagrams. The diagrams also show the bank affiliation of each I/O.

Within a given package, the number of V_{REF} and V_{CCO} pins can vary depending on the size of device. In larger devices, more I/O pins convert to V_{REF} pins. Since these are always a super set of the V_{REF} pins used for smaller devices, it is possible to design a PCB that permits migration to a larger device if necessary. All the V_{REF} pins for the largest device anticipated must be connected to the V_{REF} voltage, and not used for I/O.

In smaller devices, some V_{CCO} pins used in larger devices do not connect within the package. These unconnected pins can be left unconnected externally, or they can be connected to the V_{CCO} voltage to permit migration to a larger device, if necessary.

Configurable Logic Block

The basic building block of the Virtex-E CLB is the logic cell (LC). An LC includes a 4-input function generator, carry logic, and a storage element. The output from the function generator in each LC drives both the CLB output and the D input of the flip-flop. Each Virtex-E CLB contains four LCs, organized in two similar slices, as shown in Figure 4. Figure 5 shows a more detailed view of a single slice.

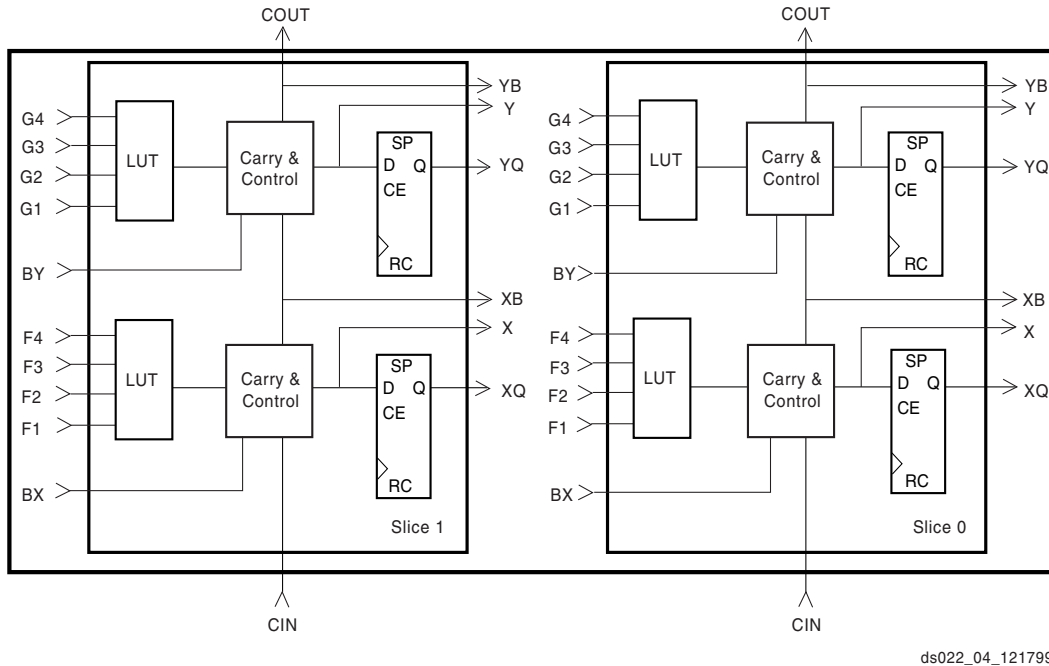

Figure 4: 2-Slice Virtex-E CLB

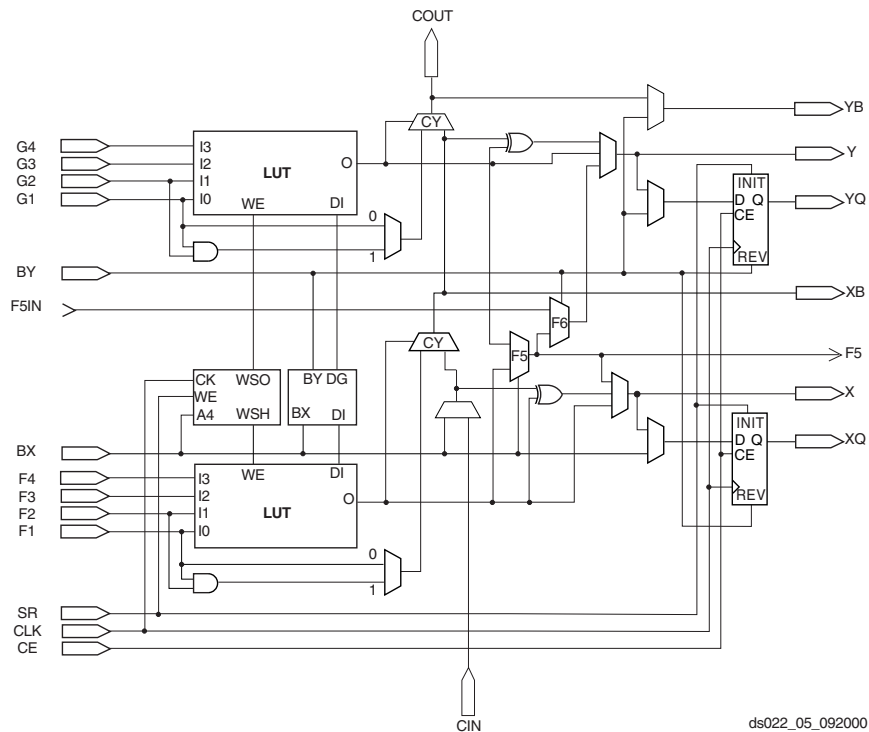

Figure 5: Detailed View of Virtex-E Slice

In addition to the four basic LCs, the Virtex-E CLB contains logic that combines function generators to provide functions of five or six inputs. Consequently, when estimating the number of system gates provided by a given device, each CLB counts as 4.5 LCs.

Look-Up Tables

Virtex-E function generators are implemented as 4-input look-up tables (LUTs). In addition to operating as a function generator, each LUT can provide a 16 x 1-bit synchronous RAM. Furthermore, the two LUTs within a slice can be com-

bined to create a 16 x 2-bit or 32 x 1-bit synchronous RAM, or a 16 x 1-bit dual-port synchronous RAM.

The Virtex-E LUT can also provide a 16-bit shift register that is ideal for capturing high-speed or burst-mode data. This mode can also be used to store data in applications such as Digital Signal Processing.

Storage Elements

The storage elements in the Virtex-E slice can be configured either as edge-triggered D-type flip-flops or as level-sensitive latches. The D inputs can be driven either by the function generators within the slice or directly from slice inputs, bypassing the function generators.

In addition to Clock and Clock Enable signals, each Slice has synchronous set and reset signals (SR and BY). SR forces a storage element into the initialization state specified for it in the configuration. BY forces it into the opposite state. Alternatively, these signals can be configured to operate asynchronously. All of the control signals are independently invertible, and are shared by the two flip-flops within the slice.

Additional Logic

The F5 multiplexer in each slice combines the function generator outputs. This combination provides either a function generator that can implement any 5-input function, a 4:1 multiplexer, or selected functions of up to nine inputs.

Similarly, the F6 multiplexer combines the outputs of all four function generators in the CLB by selecting one of the F5-multiplexer outputs. This permits the implementation of any 6-input function, an 8:1 multiplexer, or selected functions of up to 19 inputs.

Each CLB has four direct feedthrough paths, two per slice. These paths provide extra data input lines or additional local routing that does not consume logic resources.

Table 3: CLB/Block RAM Column Locations

Virtex-E Device	0	4	8	12	16	20	24	28	32	36	40	44	48	52	56	60	64	68	72	76	80	84	
XCV405E	√	√	√	√	√	√	√			√	√	√	√	√	√	√							
XCV812E	√	√	√	√	√	√	√	√	√	√			√	√	√	√	√	√	√	√	√	√	√

Table 4 shows the amount of block SelectRAM memory that is available in each Virtex-E device.

Table 4: Virtex-E Block SelectRAM Amounts

Virtex-E Device	# of Blocks	Block SelectRAM Bits
XCV405E	140	573,440
XCV812E	280	1,146,880

Arithmetic Logic

Dedicated carry logic provides fast arithmetic carry capability for high-speed arithmetic functions. The Virtex-E CLB supports two separate carry chains, one per Slice. The height of the carry chains is two bits per CLB.

The arithmetic logic includes an XOR gate that allows a 2-bit full adder to be implemented within a slice. In addition, a dedicated AND gate improves the efficiency of multiplier implementation.

The dedicated carry path can also be used to cascade function generators for implementing wide logic functions.

BUFTs

Each Virtex-E CLB contains two 3-state drivers (BUFTs) that can drive on-chip busses. See **"Dedicated Routing" on page 7**. Each Virtex-E BUFT has an independent 3-state control pin and an independent input pin.

Block SelectRAM+ Memory

Virtex-E FPGAs incorporate large block SelectRAM memories. These complement the Distributed SelectRAM memories that provide shallow RAM structures implemented in CLBs.

Block SelectRAM memory blocks are organized in columns, starting at the left (column 0) and right outside edges and inserted every four CLB columns (see notes for smaller devices). Each memory block is four CLBs high, and each memory column extends the full height of the chip, immediately adjacent (to the right, except for column 0) of the CLB column locations indicated in **Table 3**.

Each block SelectRAM cell, as illustrated in **Figure 6**, is a fully synchronous dual-ported (True Dual Port) 4096-bit RAM with independent control signals for each port. The data widths of the two ports can be configured independently, providing built-in bus-width conversion.

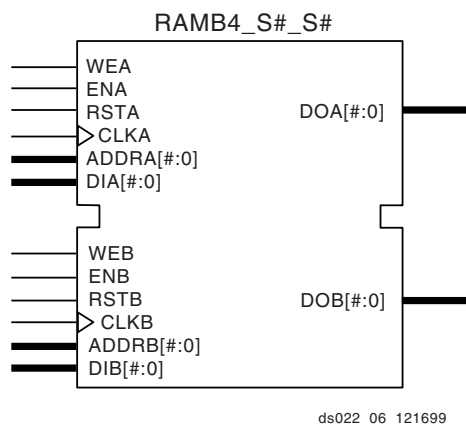

Figure 6: Dual-Port Block SelectRAM

delay of the GRM

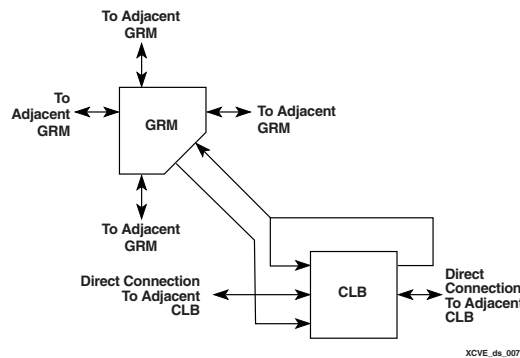

Figure 7: Virtex-E Local Routing

Table 5 shows the depth and width aspect ratios for the block SelectRAM. The Virtex-E block SelectRAM also includes dedicated routing to provide an efficient interface with both CLBs and other block SelectRAM modules. Refer to XAPP130 for block SelectRAM timing waveforms.

Table 5: Block SelectRAM Port Aspect Ratios

Width	Depth	ADDR Bus	Data Bus
1	4096	ADDR<11:0>	DATA<0>
2	2048	ADDR<10:0>	DATA<1:0>
4	1024	ADDR<9:0>	DATA<3:0>
8	512	ADDR<8:0>	DATA<7:0>
16	256	ADDR<7:0>	DATA<15:0>

Programmable Routing Matrix

It is the longest delay path that limits the speed of any worst-case design. Consequently, the Virtex-E routing architecture and its place-and-route software were defined in a joint optimization process. This joint optimization minimizes long-path delays, and consequently, yields the best system performance.

The joint optimization also reduces design compilation times because the architecture is software-friendly. Design cycles are correspondingly reduced due to shorter design iteration times.

Local Routing

The VersaBlock, shown in Figure 7, provides local routing resources with the following types of connections:

- Interconnections among the LUTs, flip-flops, and GRM
- Internal CLB feedback paths that provide high-speed connections to LUTs within the same CLB, chaining them together with minimal routing delay
- Direct paths that provide high-speed connections between horizontally adjacent CLBs, eliminating the

General Purpose Routing

Most Virtex-E signals are routed on the general purpose routing, and consequently, the majority of interconnect resources are associated with this level of the routing hierarchy. The general routing resources are located in horizontal and vertical routing channels associated with the CLB rows and columns. The general-purpose routing resources are listed below.

- Adjacent to each CLB is a General Routing Matrix (GRM). The GRM is the switch matrix through which horizontal and vertical routing resources connect, and is also the means by which the CLB gains access to the general purpose routing.
- 24 single-length lines route GRM signals to adjacent GRMs in each of the four directions.
- 72 buffered Hex lines route GRM signals to another GRMs six-blocks away in each one of the four directions. Organized in a staggered pattern, Hex lines are driven only at their endpoints. Hex-line signals can be accessed either at the endpoints or at the midpoint (three blocks from the source). One third of the Hex lines are bidirectional, while the remaining ones are uni-directional.
- 12 Longlines are buffered, bidirectional wires that distribute signals across the device quickly and efficiently. Vertical Longlines span the full height of the device, and horizontal ones span the full width of the device.

I/O Routing

Virtex-E devices have additional routing resources around their periphery that form an interface between the CLB array and the IOBs. This additional routing, called the VersaRing, facilitates pin-swapping and pin-locking, such that logic redesigns can adapt to existing PCB layouts. Time-to-market is reduced, since PCBs and other system components can be manufactured while the logic design is still in progress.

Dedicated Routing

Some signal classes require dedicated routing resources to maximize performance. In the Virtex-E architecture, dedicated routing resources are provided for two signal classes.

- Horizontal routing resources are provided for on-chip 3-state busses. Four partitionable bus lines are provided per CLB row, permitting multiple busses within a row, as shown in Figure 8.

- Two dedicated nets per CLB propagate carry signals vertically to the adjacent CLB. Global Clock Distribution Network.
- DLL Location

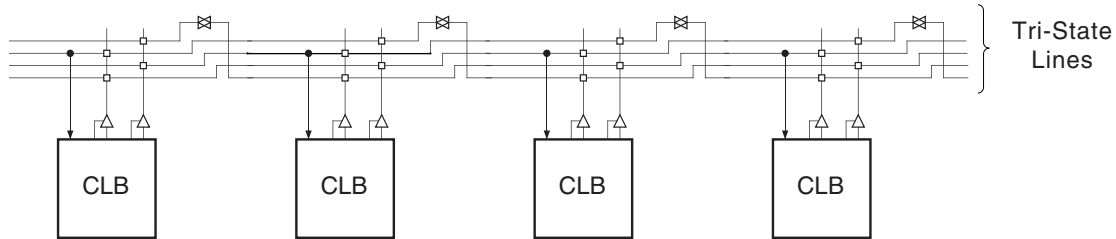

buf_t_c.eps

Figure 8: BUFT Connections to Dedicated Horizontal Bus Lines

Clock Routing

Clock Routing resources distribute clocks and other signals with very high fanout throughout the device. Virtex-E devices include two tiers of clock routing resources referred to as global and local clock routing resources.

- The global routing resources are four dedicated global nets with dedicated input pins that are designed to distribute high-fanout clock signals with minimal skew. Each global clock net can drive all CLB, IOB, and block RAM clock pins. The global nets can be driven only by global buffers. There are four global buffers, one for each global net.

- The local clock routing resources consist of 24 backbone lines, 12 across the top of the chip and 12 across bottom. From these lines, up to 12 unique signals per column can be distributed via the 12 longlines in the column. These local resources are more flexible than the global resources since they are not restricted to routing only to clock pins.

Global Clock Distribution

Virtex-E provides high-speed, low-skew clock distribution through the global routing resources described above. A typical clock distribution net is shown in Figure 9.

Four global buffers are provided, two at the top center of the device and two at the bottom center. These drive the four global nets that in turn drive any clock pin.

Four dedicated clock pads are provided, one adjacent to each of the global buffers. The input to the global buffer is selected either from these pads or from signals in the general purpose routing.

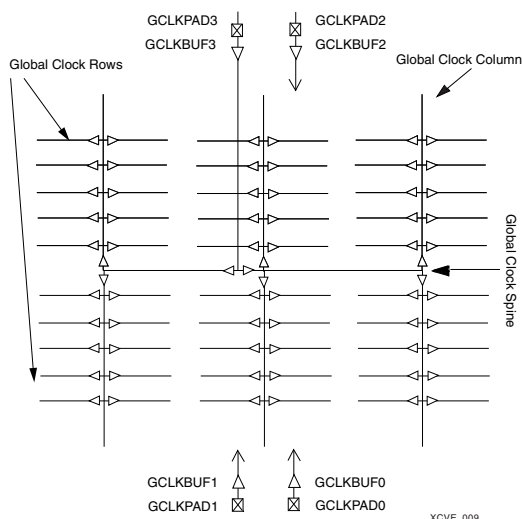

xcve_009

Figure 9: Global Clock Distribution Network

Digital Delay-Locked Loops

There are eight DLLs (Delay-Locked Loops) per device, with four located at the top and four at the bottom, Figure 10. The DLLs can be used to eliminate skew between the clock input pad and the internal clock input pins throughout the device. Each DLL can drive two global clock networks. The DLL monitors the input clock and the distributed clock, and automatically adjusts a clock delay element. Additional delay is introduced such that clock edges arrive at internal flip-flops synchronized with clock edges arriving at the input.

In addition to eliminating clock-distribution delay, the DLL provides advanced control of multiple clock domains. The

DLL provides four quadrature phases of the source clock, and can double the clock or divide the clock by 1.5, 2, 2.5, 3, 4, 5, 8, or 16.

The DLL also operates as a clock mirror. By driving the output from a DLL off-chip and then back on again, the DLL can be used to de-skew a board level clock among multiple devices.

In order to guarantee that the system clock is operating correctly prior to the FPGA starting up after configuration, the DLL can delay the completion of the configuration process until after it has achieved lock.

For more information about DLL functionality, see the Design Consideration section of the data sheet.

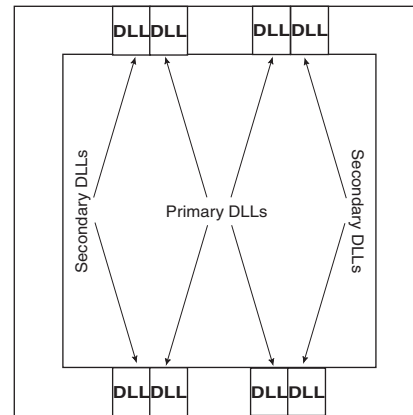

XCVE_0010

Figure 10: DLL Locations

Boundary Scan

Virtex-E devices support all the mandatory boundary-scan instructions specified in the IEEE standard 1149.1. A Test Access Port (TAP) and registers are provided that implement the EXTEST, INTEST, SAMPLE/PRELOAD, BYPASS, IDCODE, USERCODE, and HIGHZ instructions. The TAP also supports two internal scan chains and configuration/readback of the device.

The JTAG input pins (TDI, TMS, TCK) do not have a V_{CCO} requirement, and operate with either 2.5 V or 3.3 V input signalling levels. The output pin (TDO) is sourced from the V_{CCO} in bank 2, and for proper operation of LVTTTL 3.3 V levels, the bank should be supplied with 3.3 V.

Boundary-scan operation is independent of individual IOB configurations, and unaffected by package type. All IOBs, including un-bonded ones, are treated as independent 3-state bidirectional pins in a single scan chain. Retention of the bidirectional test capability after configuration facilitates

the testing of external interconnections, provided the user design or application is turned off.

Table 6 lists the boundary-scan instructions supported in Virtex-E FPGAs. Internal signals can be captured during EXTEST by connecting them to un-bonded or unused IOBs. They can also be connected to the unused outputs of IOBs defined as unidirectional input pins.

Before the device is configured, all instructions except USER1 and USER2 are available. After configuration, all instructions are available. During configuration, it is recommended that those operations using the boundary-scan register (SAMPLE/PRELOAD, INTEST, EXTEST) not be performed.

In addition to the test instructions outlined above, the boundary-scan circuitry can be used to configure the FPGA, and also to read back the configuration data.

Figure 11 is a diagram of the Virtex-E Series boundary scan logic. It includes three bits of Data Register per IOB, the IEEE 1149.1 Test Access Port controller, and the Instruction Register with decodes.

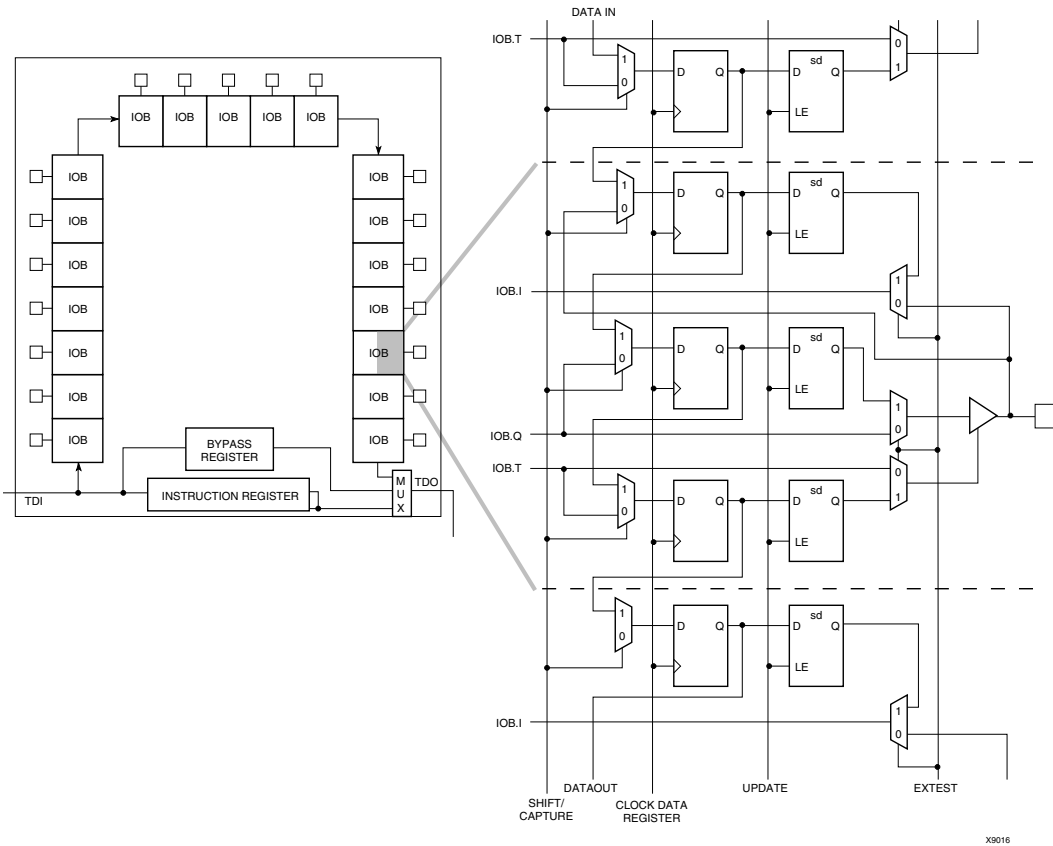

Figure 11: Virtex-E Family Boundary Scan Logic

Table 6: Boundary Scan Instructions

Boundary-Scan Command	Binary Code (4:0)	Description
EXTEST	00000	Enable boundary-scan EXTEST operation.
SAMPLE/PRELOAD	00001	Enable boundary-scan SAMPLE/PRELOAD operation.
USER1	00010	Access user-defined register 1.
USER2	00011	Access user-defined register 2.
CFG_OUT	00100	Access the configuration bus for read operations.
CFG_IN	00101	Access the configuration bus for write operations.
INTEST	00111	Enable boundary-scan INTEST operation.
USERCODE	01000	Enable shifting out USER code.
IDCODE	01001	Enable shifting out of ID Code.
HIGHZ	01010	3-state output pins while enabling the Bypass Register.
JSTART	01100	Clock the start-up sequence when StartupClk is TCK.
BYPASS	11111	Enable BYPASS.
RESERVED	All other codes	Xilinx reserved instructions.

Instruction Set

The Virtex-E Series boundary scan instruction set also includes instructions to configure the device and read back configuration data (CFG_IN, CFG_OUT, and JSTART). The complete instruction set is coded as shown in [Table 6](#).

Data Registers

The primary data register is the boundary scan register. For each IOB pin in the FPGA, bonded or not, it includes three bits for In, Out, and 3-State Control. Non-IOB pins have appropriate partial bit population if input-only or output-only.

Each EXTEST CAPTURED-OR state captures all In, Out, and 3-state pins.

The other standard data register is the single flip-flop BYPASS register. It synchronizes data being passed through the FPGA to the next downstream boundary scan device.

The FPGA supports up to two additional internal scan chains that can be specified using the BSCAN macro. The macro provides two user pins (SEL1 and SEL2) which are decoded of the USER1 and USER2 instructions respectively. For these instructions, two corresponding pins (TDO1 and TDO2) allow user scan data to be shifted out of TDO.

Likewise, there are individual clock pins (DRCK1 and DRCK2) for each user register. There is a common input pin (TDI) and shared output pins that represent the state of the TAP controller (RESET, SHIFT, and UPDATE).

Bit Sequence

The order within each IOB is: In, Out, 3-State. The input-only pins contribute only the In bit to the boundary scan I/O data register, while the output-only pins contributes all three bits.

From a cavity-up view of the chip (as shown in EPIC), starting in the upper right chip corner, the boundary scan data-register bits are ordered as shown in [Figure 12](#).

BSDL (Boundary Scan Description Language) files for Virtex-E Series devices are available on the Xilinx web site in the File Download area.

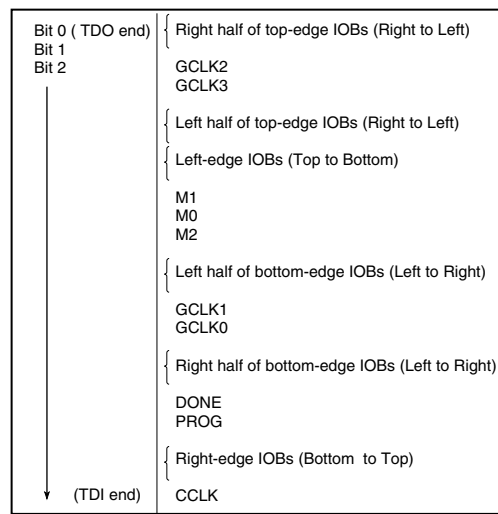

990602001

Figure 12: Boundary Scan Bit Sequence

Identification Registers

The IDCODE register is supported. By using the IDCODE, the device connected to the JTAG port can be determined.

The IDCODE register has the following binary format:

vvvv:ffff:ffa:aaaa:aaaa:cccc:cccc:ccc1

where

v = the die version number

f = the family code (05 for Virtex-E family)

a = the number of CLB rows (ranges from 16 for XCV50E to 104 for XCV3200E)

c = the company code (49h for Xilinx)

The USERCODE register is supported. By using the USERCODE, a user-programmable identification code can be loaded and shifted out for examination. The identification code (see Table 7) is embedded in the bitstream during bitstream generation and is valid only after configuration.

Development System

Virtex-E FPGAs are supported by the Xilinx Foundation and Alliance Series CAE tools. The basic methodology for Virtex-E design consists of three interrelated steps: design entry, implementation, and verification. Industry-standard tools are used for design entry and simulation (for example, Synopsys FPGA Express), while Xilinx provides proprietary architecture-specific tools for implementation.

The Xilinx development system is integrated under the Xilinx Design Manager (XDM™) software, providing designers with a common user interface regardless of their choice of entry and verification tools. The XDM software simplifies the selection of implementation options with pull-down menus and on-line help.

Application programs ranging from schematic capture to Placement and Routing (PAR) can be accessed through the XDM software. The program command sequence is generated prior to execution, and stored for documentation.

Several advanced software features facilitate Virtex-E design. RPMs, for example, are schematic-based macros with relative location constraints to guide their placement. They help ensure optimal implementation of common functions.

For HDL design entry, the Xilinx FPGA Foundation development system provides interfaces to the following synthesis design environments.

- Synopsys (FPGA Compiler, FPGA Express)
- Exemplar (Spectrum)
- Synplicity (Synplify)

For schematic design entry, the Xilinx FPGA Foundation and Alliance development system provides interfaces to the following schematic-capture design environments.

- Mentor Graphics V8 (Design Architect, QuickSim II)
- Viewlogic Systems (Viewdraw)

Third-party vendors support many other environments.

Table 7: IDCODEs Assigned to Virtex-E FPGAs

FPGA	IDCODE
XCV405EM	v0C28093h
XCV812EM	v0C38093h

Note:

Attempting to load an incorrect bitstream causes configuration to fail and can damage the device.

Including Boundary Scan in a Design

Since the boundary scan pins are dedicated, no special element needs to be added to the design unless an internal data register (USER1 or USER2) is desired.

If an internal data register is used, insert the boundary scan symbol and connect the necessary pins as appropriate.

A standard interface-file specification, Electronic Design Interchange Format (EDIF), simplifies file transfers into and out of the development system.

Virtex-E FPGAs are supported by a unified library of standard functions. This library contains over 400 primitives and macros, ranging from 2-input AND gates to 16-bit accumulators, and includes arithmetic functions, comparators, counters, data registers, decoders, encoders, I/O functions, latches, Boolean functions, multiplexers, shift registers, and barrel shifters.

The “soft macro” portion of the library contains detailed descriptions of common logic functions, but does not contain any partitioning or placement information. The performance of these macros depends, therefore, on the partitioning and placement obtained during implementation.

RPMs, on the other hand, do contain predetermined partitioning and placement information that permits optimal implementation of these functions. Users can create their own library of soft macros or RPMs based on the macros and primitives in the standard library.

The design environment supports hierarchical design entry, with high-level schematics that comprise major functional blocks, while lower-level schematics define the logic in these blocks. These hierarchical design elements are automatically combined by the implementation tools. Different design entry tools can be combined within a hierarchical design, thus allowing the most convenient entry method to be used for each portion of the design.

Design Implementation

The place-and-route tools (PAR) automatically provide the implementation flow described in this section. The partitioner takes the EDIF net list for the design and maps the logic into the architectural resources of the FPGA (CLBs and IOBs, for example). The placer then determines the best locations for these blocks based on their interconnec-

tions and the desired performance. Finally, the router interconnects the blocks.

The PAR algorithms support fully automatic implementation of most designs. For demanding applications, however, the user can exercise various degrees of control over the process. User partitioning, placement, and routing information is optionally specified during the design-entry process. The implementation of highly structured designs can benefit greatly from basic floor planning.

The implementation software incorporates Timing Wizard® timing-driven placement and routing. Designers specify timing requirements along entire paths during design entry. The timing path analysis routines in PAR then recognize these user-specified requirements and accommodate them.

Timing requirements are entered on a schematic in a form directly relating to the system requirements, such as the targeted clock frequency, or the maximum allowable delay between two registers. In this way, the overall performance of the system along entire signal paths is automatically tailored to user-generated specifications. Specific timing information for individual nets is unnecessary.

Configuration

Virtex-E devices are configured by loading configuration data into the internal configuration memory. Note that attempting to load an incorrect bitstream causes configuration to fail and can damage the device.

Some of the pins used for configuration are dedicated pins, while others can be re-used as general purpose inputs and outputs once configuration is complete.

The following are dedicated pins:

- Mode pins (M2, M1, M0)
- Configuration clock pin (CCLK)
- PROGRAM pin
- DONE pin
- Boundary-scan pins (TDI, TDO, TMS, TCK)

Depending on the configuration mode chosen, CCLK can be an output generated by the FPGA, or it can be generated externally and provided to the FPGA as an input. The PROGRAM pin must be pulled High prior to reconfiguration.

Note that some configuration pins can act as outputs. For correct operation, these pins require a V_{CCO} of 3.3 V to permit LVTTTL operation. All of the pins affected are in banks 2

Table 8: Configuration Codes

Configuration Mode	M2	M1	M0	CCLK Direction	Data Width	Serial D _{out}	Configuration Pull-ups
Master-serial mode	0	0	0	Out	1	Yes	No
Boundary-scan mode	1	0	1	N/A	1	No	No
SelectMAP mode	1	1	0	In	8	No	No
Slave-serial mode	1	1	1	In	1	Yes	No
Master-serial mode	1	0	0	Out	1	Yes	Yes

Design Verification

In addition to conventional software simulation, FPGA users can use in-circuit debugging techniques. Because Xilinx devices are infinitely reprogrammable, designs can be verified in real time without the need for extensive sets of software simulation vectors.

The development system supports both software simulation and in-circuit debugging techniques. For simulation, the system extracts the post-layout timing information from the design database, and back-annotates this information into the net list for use by the simulator. Alternatively, the user can verify timing-critical portions of the design using the TRCE® static timing analyzer.

For in-circuit debugging, an optional download and read-back cable is available. This cable connects the FPGA in the target system to a PC or workstation. After downloading the design into the FPGA, the designer can single-step the logic, readback the contents of the flip-flops, and so observe the internal logic state. Simple modifications can be downloaded into the system in a matter of minutes.

or 3. The configuration pins needed for SelectMap (CS, Write) are located in bank 1.

Configuration Modes

Virtex-E supports the following four configuration modes.

- Slave-serial mode
- Master-serial mode
- SelectMAP mode
- Boundary-scan mode (JTAG)

The Configuration mode pins (M2, M1, M0) select among these configuration modes with the option in each case of having the IOB pins either pulled up or left floating prior to configuration. The selection codes are listed in Table 8.

Configuration through the boundary-scan port is always available, independent of the mode selection. Selecting the boundary-scan mode simply turns off the other modes. The three mode pins have internal pull-up resistors, and default to a logic High if left unconnected. However, it is recommended to drive the configuration mode pins externally.

Table 8: Configuration Codes

Configuration Mode	M2	M1	M0	CCLK Direction	Data Width	Serial D _{out}	Configuration Pull-ups
Boundary-scan mode	0	0	1	N/A	1	No	Yes
SelectMAP mode	0	1	0	In	8	No	Yes
Slave-serial mode	0	1	1	In	1	Yes	Yes

Table 9 lists the total number of bits required to configure each device.

Table 9: Virtex-E Bitstream Lengths

Device	# of Configuration Bits
XCV405E	3,430,400
XCV812E	6,519,648

Slave-Serial Mode

In slave-serial mode, the FPGA receives configuration data in bit-serial form from a serial PROM or other source of serial configuration data. The serial bitstream must be set up at the DIN input pin a short time before each rising edge of an externally generated CCLK.

For more detailed information on serial PROMs see the PROM data sheet at [ds026.pdf](#).

Multiple FPGAs can be daisy-chained for configuration from a single source. After a particular FPGA has been config-

ured, the data for the next device is routed to the DOUT pin. Data on the DOUT pin changes on the rising edge of CCLK.

The change of DOUT on the rising edge of CCLK differs from previous families but does not cause a problem for mixed configuration chains. This change was made to improve serial configuration rates for Virtex and Virtex-E only chains.

Figure 13 shows a full master/slave system. A Virtex-E device in slave-serial mode should be connected as shown in the right-most device.

Slave-serial mode is selected by applying <111> or <011> to the mode pins (M2, M1, M0). A weak pull-up on the mode pins makes slave-serial the default mode if the pins are left unconnected. However, it is recommended to drive the configuration mode pins externally. Figure 14 shows slave-serial mode programming switching characteristics.

Table 10 provides more detail about the characteristics shown in Figure 14. Configuration must be delayed until the INIT pins of all daisy-chained FPGAs are High.

Table 10: Master/Slave Serial Mode Programming Switching

	Description	Figure References	Symbol	Values	Units
CCLK	DIN setup/hold, slave mode	1/2	T _{DCC} /T _{CCD}	5.0/0.0	ns, min
	DIN setup/hold, master mode	1/2	T _{DSCK} /T _{CKDS}	5.0/0.0	ns, min
	DOUT	3	T _{CCO}	12.0	ns, max
	High time	4	T _{CCH}	5.0	ns, min
	Low time	5	T _{CCL}	5.0	ns, min
	Maximum Frequency		F _{CC}	66	MHz, max
	Frequency Tolerance, master mode with respect to nominal			+45% -30%	

The sequence of operations necessary to configure a Virtex-E FPGA serially appears in Figure 15.

Figure 16 shows the timing of master-serial configuration. Master-serial mode is selected by a <000> or <100> on the mode pins (M2, M1, M0). Table 10 shows the timing information for Figure 16

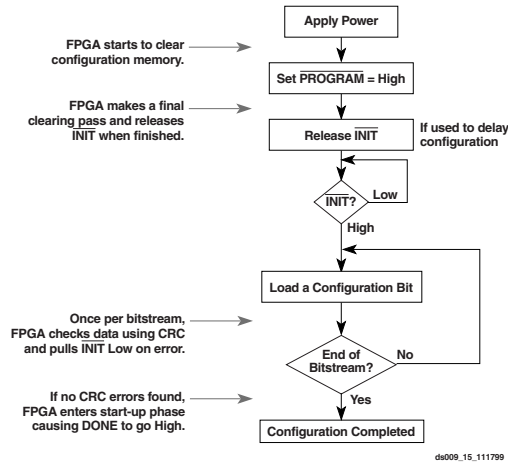

Figure 15: Serial Configuration Flowchart

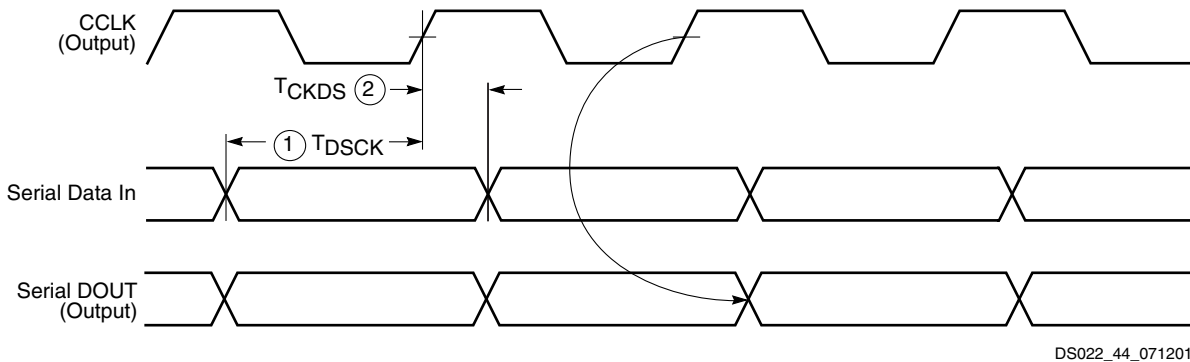

Figure 16: Master-Serial Mode Programming Switching Characteristics

At power-up, V_{CC} must rise from 1.0 V to V_{CC} min in less than 50 ms, otherwise delay configuration by pulling $\overline{PROGRAM}$ Low until V_{CC} is valid.

SelectMAP Mode

The SelectMAP mode is the fastest configuration option. Byte-wide data is written into the FPGA with a $BUSY$ flag controlling the flow of data.

An external data source provides a byte stream, CCLK, a Chip Select (\overline{CS}) signal and a Write signal (\overline{WRITE}). If $BUSY$ is asserted (High) by the FPGA, the data must be held until $BUSY$ goes Low.

Data can also be read using the SelectMAP mode. If \overline{WRITE} is not asserted, configuration data is read out of the FPGA as part of a readback operation.

After configuration, the pins of the SelectMAP port can be used as additional user I/O. Alternatively, the port can be retained to permit high-speed 8-bit readback.

Retention of the SelectMAP port is selectable on a design-by-design basis when the bitstream is generated. If

retention is selected, PROHIBIT constraints are required to prevent SelectMAP-port pins from being used as user I/O.

Multiple Virtex-E FPGAs can be configured using the SelectMAP mode, and be made to start-up simultaneously. To configure multiple devices in this way, wire the individual CCLK, Data, \overline{WRITE} , and $BUSY$ pins of all the devices in parallel. The individual devices are loaded separately by asserting the \overline{CS} pin of each device in turn and writing the appropriate data. See Table 11 for SelectMAP Write Timing Characteristics.

Write

Write operations send packets of configuration data into the FPGA. The sequence of operations for a multi-cycle write operation is shown below. Note that a configuration packet can be split into many such sequences. The packet does not have to complete within one assertion of \overline{CS} , illustrated in Figure 17.

1. Assert \overline{WRITE} and \overline{CS} Low. Note that when \overline{CS} is asserted on successive CCLKs, \overline{WRITE} must remain

- either asserted or de-asserted. Otherwise an abort is initiated, as described below.
2. Drive data onto D[7:0]. Note that to avoid contention, the data source should not be enabled while \overline{CS} is Low and \overline{WRITE} is High. Similarly, while \overline{WRITE} is High, no more than one \overline{CS} should be asserted.
 3. At the rising edge of CCLK: If BUSY is Low, the data is accepted on this clock. If BUSY is High (from a previous write), the data is not accepted. Acceptance instead occurs on the first clock after BUSY goes Low, and the data must be held until this has happened.
 4. Repeat steps 2 and 3 until all the data has been sent.
 5. De-assert \overline{CS} and \overline{WRITE} .

Table 11: SelectMAP Write Timing Characteristics

	Description		Symbol	Values	Units
CCLK	D ₀₋₇ Setup/Hold	1/2	T _{SMDC} /T _{SMCCD}	5.0 / 1.7	ns, min
	\overline{CS} Setup/Hold	3/4	T _{SMSCC} /T _{SMCCS}	7.0 / 1.7	ns, min
	\overline{WRITE} Setup/Hold	5/6	T _{SMCCW} /T _{SMWCC}	7.0 / 1.7	ns, min
	BUSY Propagation Delay	7	T _{SMCKBY}	12.0	ns, max
	Maximum Frequency		F _{CC}	66	MHz, max
	Maximum Frequency with no handshake		F _{CCNH}	50	MHz, max

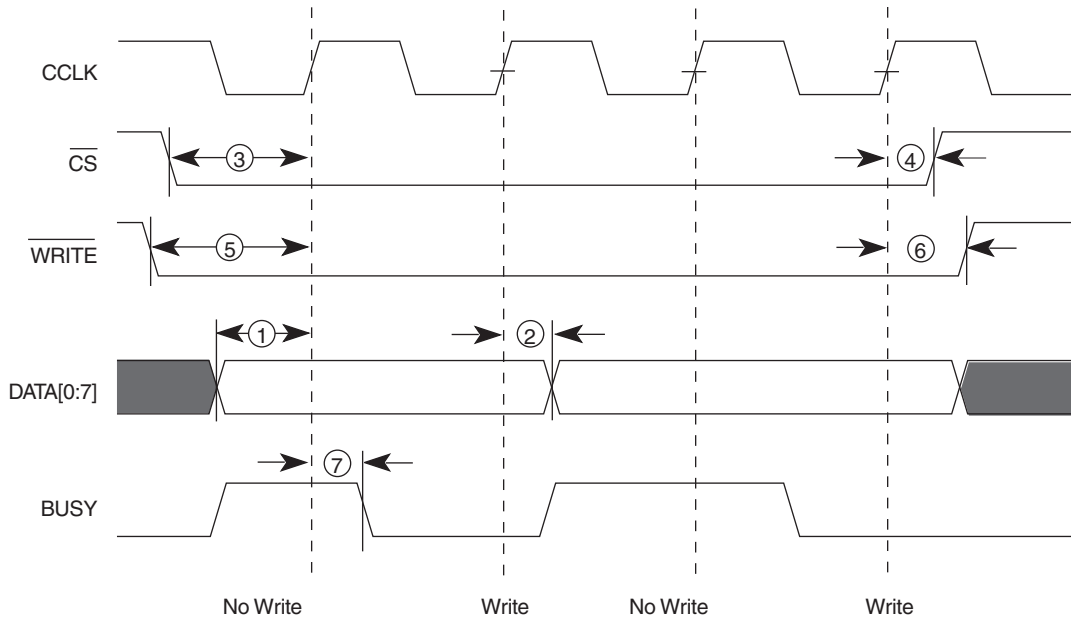

DS022_45_071702

Figure 17: Write Operations

A flowchart for the write operation appears in Figure 18. Note that if CCLK is slower than f_{CCNH} , the FPGA never asserts BUSY. In this case, the above handshake is unnecessary, and data can simply be entered into the FPGA every CCLK cycle.

Abort

During a given assertion of \overline{CS} , the user cannot switch from a write to a read, or vice-versa. This action causes the cur-

rent packet command to be aborted. The device remains BUSY until the aborted operation has completed. Following an abort, data is assumed to be unaligned to word boundaries, and the FPGA requires a new synchronization word prior to accepting any new packets.

To initiate an abort during a write operation, de-assert \overline{WRITE} . At the rising edge of CCLK, an abort is initiated, as shown in Figure 19.

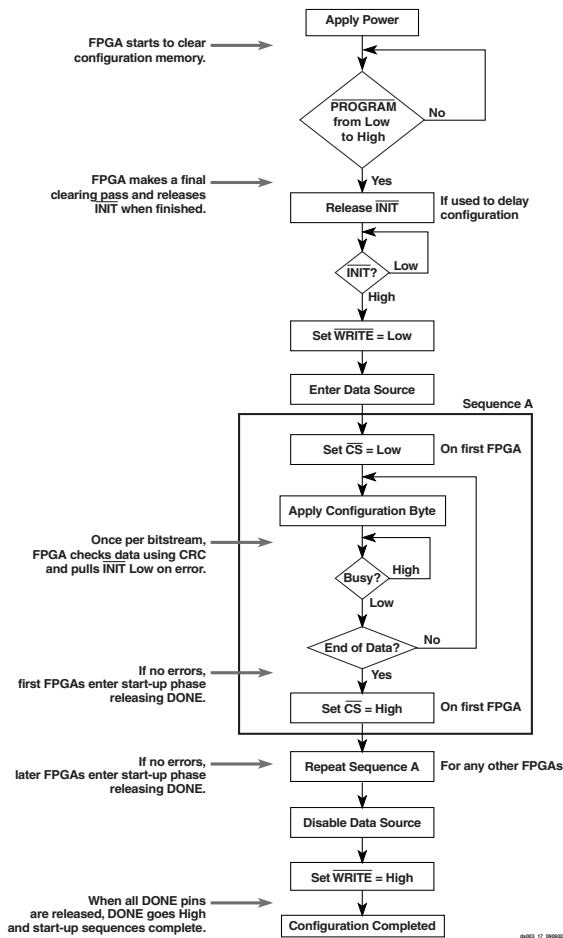

Figure 18: SelectMAP Flowchart for Write Operations

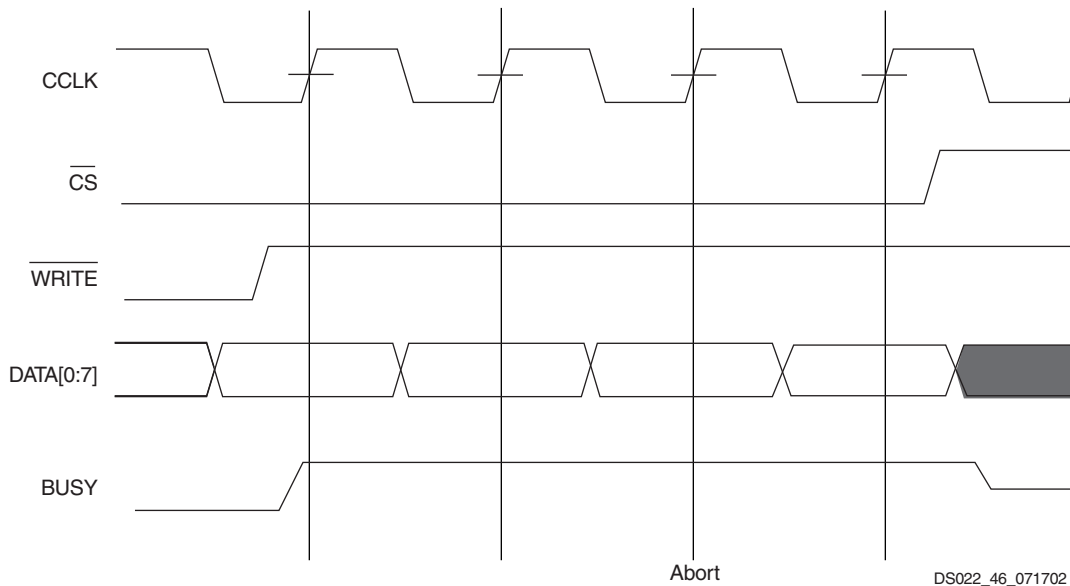

Figure 19: SelectMAP Write Abort Waveforms

Boundary-Scan Mode

In the boundary-scan mode, configuration is done through the IEEE 1149.1 Test Access Port. Note that the

PROGRAM pin must be pulled High prior to reconfiguration. A Low on the PROGRAM pin resets the TAP controller and no JTAG operations can be performed.

Configuration through the TAP uses the CFG_IN instruction. This instruction allows data input on TDI to be converted into data packets for the internal configuration bus.

The following steps are required to configure the FPGA through the boundary-scan port (when using TCK as a start-up clock).

1. Load the CFG_IN instruction into the boundary-scan instruction register (IR)
2. Enter the Shift-DR (SDR) state
3. Shift a configuration bitstream into TDI
4. Return to Run-Test-Idle (RTI)
5. Load the JSTART instruction into IR
6. Enter the SDR state
7. Clock TCK through the startup sequence
8. Return to RTI

Configuration and readback via the TAP is always available. The boundary-scan mode is selected by a <101> or <001>

on the mode pins (M2, M1, M0). For details on TAP characteristics, refer to XAPP139.

Configuration Sequence

The configuration of Virtex-E devices is a three-phase process. First, the configuration memory is cleared. Next, configuration data is loaded into the memory, and finally, the logic is activated by a start-up process.

Configuration is automatically initiated on power-up unless it is delayed by the user, as described below. The configuration process can also be initiated by asserting PROGRAM. The end of the memory-clearing phase is signalled by INIT going High, and the completion of the entire process is signalled by DONE going High.

The power-up timing of configuration signals is shown in **Figure 20**.

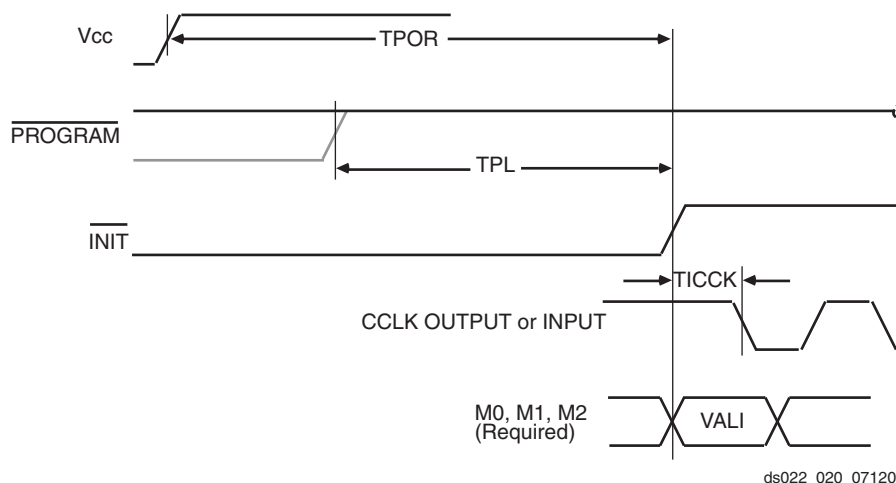

ds022_020_071201

Figure 20: Power-Up Timing Configuration Signals

The corresponding timing characteristics are listed in **Table 12**.

Table 12: Power-up Timing Characteristics

Description	Symbol	Value	Units
Power-on Reset ¹	T _{POR}	2.0	ms, max
Program Latency	T _{PL}	100.0	μs, max
CCLK (output) Delay	T _{ICCK}	0.5	μs, min
		4.0	μs, max
Program Pulse Width	T _{PROGRAM}	300	ns, min

Notes:

1. T_{POR} delay is the initialization time required after V_{CCINT} reaches the recommended operating voltage.

Delaying Configuration

INIT can be held Low using an open-drain driver. An open-drain is required since INIT is a bidirectional open-drain pin that is held Low by the FPGA while the configuration memory is being cleared. Extending the time that the pin is Low causes the configuration sequencer to wait. Thus, configuration is delayed by preventing entry into the phase where data is loaded.

Start-Up Sequence

The default Start-up sequence is that one CCLK cycle after DONE goes High, the global 3-state signal (GTS) is released. This permits device outputs to turn on as necessary.

One CCLK cycle later, the Global Set/Reset (GSR) and Global Write Enable (GWE) signals are released. This per-

mits the internal storage elements to begin changing state in response to the logic and the user clock.

The relative timing of these events can be changed. In addition, the GTS, GSR, and GWE events can be made depen-

Readback

The configuration data stored in the Virtex-E configuration memory can be readback for verification. Along with the configuration data it is possible to readback the contents all flip-flops/latches, LUT RAMs, and block RAMs. This capa-

ment on the DONE pins of multiple devices all going High, forcing the devices to start synchronously. The sequence can also be paused at any stage until lock has been achieved on any or all DLLs.

bility is used for real-time debugging. For more detailed information, see application note XAPP138 “Virtex FPGA Series Configuration and Readback”.

Design Considerations

This section contains more detailed design information on the following features.

- Delay-Locked Loop . . . see [page 20](#)
- BlockRAM . . . see [page 24](#)
- Select/O . . . see [page 31](#)

Using DLLs

The Virtex-E FPGA series provides up to eight fully digital dedicated on-chip Delay-Locked Loop (DLL) circuits which provide zero propagation delay, low clock skew between output clock signals distributed throughout the device, and advanced clock domain control. These dedicated DLLs can be used to implement several circuits which improve and simplify system level design.

Introduction

As FPGAs grow in size, quality on-chip clock distribution becomes increasingly important. Clock skew and clock delay impact device performance and the task of managing clock skew and clock delay with conventional clock trees becomes more difficult in large devices. The Virtex-E series of devices resolve this potential problem by providing up to eight fully digital dedicated on-chip DLL circuits which provide zero propagation delay and low clock skew between output clock signals distributed throughout the device.

Each DLL can drive up to two global clock routing networks within the device. The global clock distribution network minimizes clock skews due to loading differences. By monitoring a sample of the DLL output clock, the DLL can compensate for the delay on the routing network, effectively eliminating the delay from the external input port to the individual clock loads within the device.

In addition to providing zero delay with respect to a user source clock, the DLL can provide multiple phases of the source clock. The DLL can also act as a clock doubler or it can divide the user source clock by up to 16.

Clock multiplication gives the designer a number of design alternatives. For instance, a 50 MHz source clock doubled by the DLL can drive an FPGA design operating at 100 MHz. This technique can simplify board design because the clock path on the board no longer distributes such a high-speed signal. A multiplied clock also provides designers the option of time-domain-multiplexing, using one circuit twice per clock cycle, consuming less area than two copies of the same circuit. Two DLLs in can be connected in series to increase the effective clock multiplication factor to four.

The DLL can also act as a clock mirror. By driving the DLL output off-chip and then back in again, the DLL can be used to de-skew a board level clock between multiple devices.

In order to guarantee the system clock establishes prior to the device “waking up,” the DLL can delay the completion of the device configuration process until after the DLL achieves lock.

By taking advantage of the DLL to remove on-chip clock delay, the designer can greatly simplify and improve system level design involving high-fanout, high-performance clocks.

Library DLL Symbols

Figure 21 shows the simplified Xilinx library DLL macro symbol, BUFGDLL. This macro delivers a quick and efficient way to provide a system clock with zero propagation delay throughout the device. **Figure 22** and **Figure 23** show the two library DLL primitives. These symbols provide access to the complete set of DLL features when implementing more complex applications.

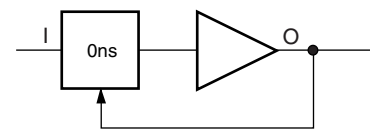

ds022_25_121099

Figure 21: Simplified DLL Macro Symbol BUFGDLL

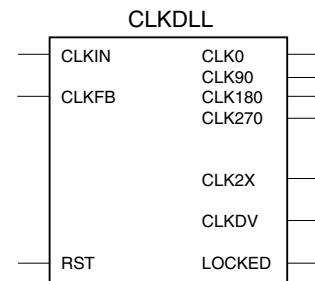

ds022_26_121099

Figure 22: Standard DLL Symbol CLKDLL

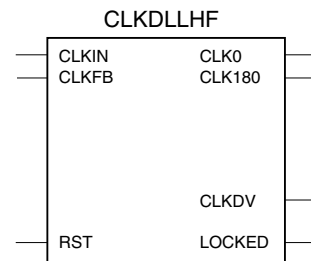

ds022_027_121099

Figure 23: High Frequency DLL Symbol

BUFGDLL Pin Descriptions

Use the BUFGDLL macro as the simplest way to provide zero propagation delay for a high-fanout on-chip clock from an external input. This macro uses the IBUFG, CLKDLL and BUFG primitives to implement the most basic DLL application as shown in Figure 24.

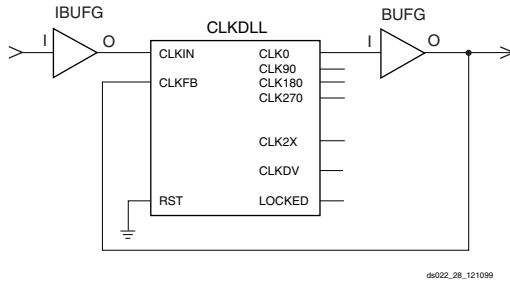

Figure 24: BUFGDLL Schematic

This symbol does not provide access to the advanced clock domain controls or to the clock multiplication or clock division features of the DLL. This symbol also does not provide access to the RST, or LOCKED pins of the DLL. For access to these features, a designer must use the library DLL primitives described in the following sections.

Source Clock Input — I

The I pin provides the user source clock, the clock signal on which the DLL operates, to the BUFGDLL. For the BUFGDLL macro the source clock frequency must fall in the low frequency range as specified in the data sheet. The BUFGDLL requires an external signal source clock. Therefore, only an external input port can source the signal that drives the BUFGDLL I pin.

Clock Output — O

The clock output pin O represents a delay-compensated version of the source clock (I) signal. This signal, sourced by a global clock buffer BUFG symbol, takes advantage of the dedicated global clock routing resources of the device.

The output clock has a 50-50 duty cycle unless you deactivate the duty cycle correction property.

CLKDLL Primitive Pin Descriptions

The library CLKDLL primitives provide access to the complete set of DLL features needed when implementing more complex applications with the DLL.

Source Clock Input — CLKIN

The CLKIN pin provides the user source clock (the clock signal on which the DLL operates) to the DLL. The CLKIN frequency must fall in the ranges specified in the data sheet. A global clock buffer (BUFG) driven from another CLKDLL, one of the global clock input buffers (IBUFG), or an IO_LVDS_DLL pin on the same edge of the device (top or bottom) must source this clock signal. There are four IO_LVDS_DLL input pins that can be used as inputs to the

DLLs. This makes a total of eight usable input pins for DLLs in the Virtex-E family.

Feedback Clock Input — CLKFB

The DLL requires a reference or feedback signal to provide the delay-compensated output. Connect only the CLK0 or CLK2X DLL outputs to the feedback clock input (CLKFB) pin to provide the necessary feedback to the DLL. The feedback clock input can also be provided through one of the following pins.

IBUFG - Global Clock Input Pad

IO_LVDS_DLL - the pin adjacent to IBUFG

If an IBUFG sources the CLKFB pin, the following special rules apply.

1. An external input port must source the signal that drives the IBUFG I pin.
2. The CLK2X output must feedback to the device if both the CLK0 and CLK2X outputs are driving off chip devices.
3. That signal must directly drive only OBUFs and nothing else.

These rules enable the software determine which DLL clock output sources the CLKFB pin.

Reset Input — RST

When the reset pin RST activates the LOCKED signal deactivates within four source clock cycles. The RST pin, active High, must either connect to a dynamic signal or tied to ground. As the DLL delay taps reset to zero, glitches can occur on the DLL clock output pins. Activation of the RST pin can also severely affect the duty cycle of the clock output pins. Furthermore, the DLL output clocks no longer de-skew with respect to one another. For these reasons, rarely use the reset pin unless re-configuring the device or changing the input frequency.

2x Clock Output — CLK2X

The output pin CLK2X provides a frequency-doubled clock with an automatic 50/50 duty-cycle correction. Until the CLKDLL has achieved lock, the CLK2X output appears as a 1x version of the input clock with a 25/75 duty cycle. This behavior allows the DLL to lock on the correct edge with respect to source clock. This pin is not available on the CLK-DLLHF primitive.

Clock Divide Output — CLKDV

The clock divide output pin CLKDV provides a lower frequency version of the source clock. The CLKDV_DIVIDE property controls CLKDV such that the source clock is divided by N where N is either 1.5, 2, 2.5, 3, 4, 5, 8, or 16.

This feature provides automatic duty cycle correction such that the CLKDV output pin always has a 50/50 duty cycle, with the exception of noninteger divides in HF mode, where the duty cycle is 1/3 for N=1.5 and 2/5 for N=2.5.

1x Clock Outputs — CLK[0|90|180|270]

The 1x clock output pin CLK0 represents a delay-compensated version of the source clock (CLKIN) signal. The CLKDLL primitive provides three phase-shifted versions of the CLK0 signal while CLKDLLHF provides only the 180 phase-shifted version. The relationship between phase shift and the corresponding period shift appears in [Table 13](#).

Table 13: Relationship of Phase-Shifted Output Clock to Period Shift

Phase (degrees)	Period Shift (percent)
0	0%
90	25%
180	50%
270	75%

The timing diagrams in [Figure 25](#) illustrate the DLL clock output characteristics.

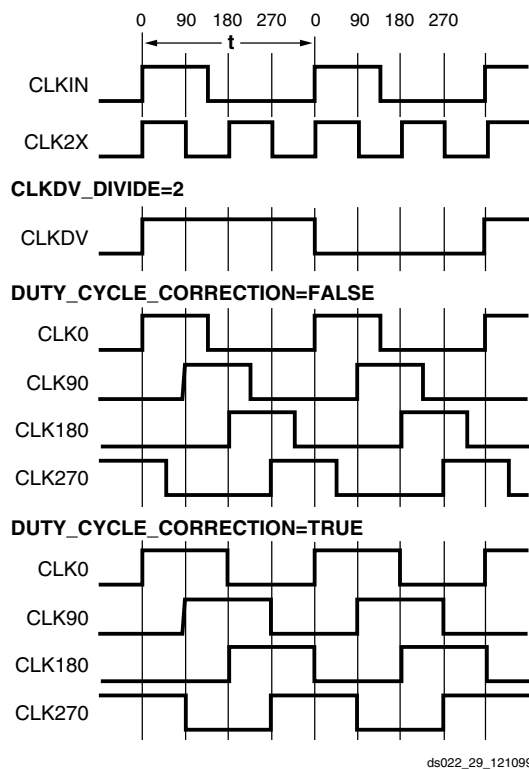

Figure 25: DLL Output Characteristics

The DLL provides duty cycle correction on all 1x clock outputs such that all 1x clock outputs by default have a 50/50 duty cycle. The DUTY_CYCLE_CORRECTION property (TRUE by default), controls this feature. In order to deactivate the DLL duty cycle correction, attach the DUTY_CYCLE_CORRECTION=FALSE property to the DLL symbol. When duty cycle correction deactivates, the output clock has the same duty cycle as the source clock.

The DLL clock outputs can drive an OBUF, a BUFG, or they can route directly to destination clock pins. The DLL clock outputs can only drive the BUFGs that reside on the same edge (top or bottom).

Locked Output — LOCKED

To achieve lock, the DLL might need to sample several thousand clock cycles. After the DLL achieves lock, the LOCKED signal activates. The DLL timing parameter section of the data sheet provides estimates for locking times.

To guarantee that the system clock is established prior to the device “waking up,” the DLL can delay the completion of the device configuration process until after the DLL locks. The STARTUP_WAIT property activates this feature.

Until the LOCKED signal activates, the DLL output clocks are not valid and can exhibit glitches, spikes, or other spurious movement. In particular the CLK2X output appears as a 1x clock with a 25/75 duty cycle.

DLL Properties

Properties provide access to some of the Virtex-E series DLL features, (for example, clock division and duty cycle correction).

Duty Cycle Correction Property

The 1x clock outputs, CLK0, CLK90, CLK180, and CLK270, use the duty-cycle corrected default, exhibiting a 50/50 duty cycle. The DUTY_CYCLE_CORRECTION property (by default TRUE) controls this feature. To deactivate the DLL duty-cycle correction for the 1x clock outputs, attach the DUTY_CYCLE_CORRECTION=FALSE property to the DLL symbol.

Clock Divide Property

The CLKDV_DIVIDE property specifies how the signal on the CLKDV pin is frequency divided with respect to the CLK0 pin. The values allowed for this property are 1.5, 2, 2.5, 3, 4, 5, 8, or 16; the default value is 2.

Startup Delay Property

This property, STARTUP_WAIT, takes on a value of TRUE or FALSE (the default value). When TRUE the device configuration DONE signal waits until the DLL locks before going to High.

Virtex-E DLL Location Constraints

As shown in [Figure 26](#), there are four additional DLLs in the Virtex-E devices, for a total of eight per Virtex-E device. These DLLs are located in silicon, at the top and bottom of the two innermost block SelectRAM columns. The location constraint LOC, attached to the DLL symbol with the identifier DLL0S, DLL0P, DLL1S, DLL1P, DLL2S, DLL2P, DLL3S, or DLL3P, controls the DLL location.

The LOC property uses the following form:

$$LOC = DLL0P$$

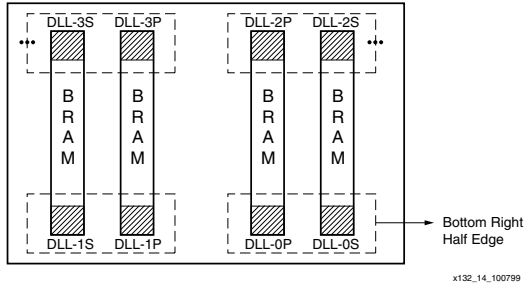

Figure 26: Virtex Series DLLs

Design Factors

Use the following design considerations to avoid pitfalls and improve success designing with Xilinx devices.

Input Clock

The output clock signal of a DLL, essentially a delayed version of the input clock signal, reflects any instability on the input clock in the output waveform. For this reason the quality of the DLL input clock relates directly to the quality of the output clock waveforms generated by the DLL. The DLL input clock requirements are specified in the data sheet.

In most systems a crystal oscillator generates the system clock. The DLL can be used with any commercially available quartz crystal oscillator. For example, most crystal oscillators produce an output waveform with a frequency tolerance of 100 PPM, meaning 0.01 percent change in the clock period. The DLL operates reliably on an input waveform with a frequency drift of up to 1 ns — orders of magnitude in excess of that needed to support any crystal oscillator in the industry. However, the cycle-to-cycle jitter must be kept to less than 300 ps in the low frequencies and 150 ps for the high frequencies.

Input Clock Changes

Changing the period of the input clock beyond the maximum drift amount requires a manual reset of the CLKDLL. Failure to reset the DLL produces an unreliable lock signal and output clock.

It is possible to stop the input clock with little impact to the DLL. Stopping the clock should be limited to less than 100 μ s to keep device cooling to a minimum. The clock should be stopped during a Low phase, and when restored the full High period should be seen. During this time LOCKED stays High and remains High when the clock is restored.

When the clock is stopped, one to four more clocks are still observed as the delay line is flushed. When the clock is restarted, the output clocks are not observed for one to four clocks as the delay line is filled. The most common case is two or three clocks.

In a similar manner, a phase shift of the input clock is also possible. The phase shift propagates one to four clocks to the output after the original shift, with no disruption to the CLKDLL control.

Output Clocks

As mentioned earlier in the DLL pin descriptions, some restrictions apply regarding the connectivity of the output pins. The DLL clock outputs can drive an OBUF, a global clock buffer BUFG, or they can route directly to destination clock pins. The only BUFGs that the DLL clock outputs can drive are the two on the same edge of the device (top or bottom). In addition, the CLK2X output of the secondary DLL can connect directly to the CLKIN of the primary DLL in the same quadrant.

Do not use the DLL output clock signals until after activation of the LOCKED signal. Prior to the activation of the LOCKED signal, the DLL output clocks are not valid and can exhibit glitches, spikes, or other spurious movement.

Useful Application Examples

The Virtex-E DLL can be used in a variety of creative and useful applications. The following examples show some of the more common applications. The Verilog and VHDL example files are available at:

<ftp://ftp.xilinx.com/pub/applications/xapp/xapp132.zip>

Standard Usage

The circuit shown in Figure 27 resembles the BUFGDLL macro implemented to provide access to the RST and LOCKED pins of the CLKDLL.

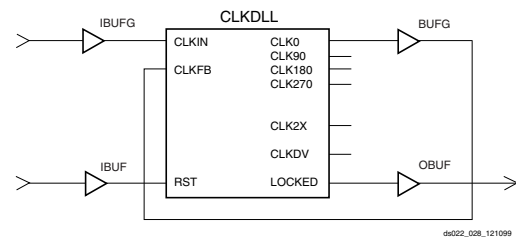

Figure 27: Standard DLL Implementation

Board Level De-Skew of Multiple Non-Virtex-E Devices

The circuit shown in Figure 28 can be used to de-skew a system clock between a Virtex-E chip and other non-Virtex-E chips on the same board. This application is commonly used when the Virtex-E device is used in conjunction with other standard products such as SRAM or DRAM devices. While designing the board level route, ensure that the return net delay to the source equals the delay to the other chips involved.

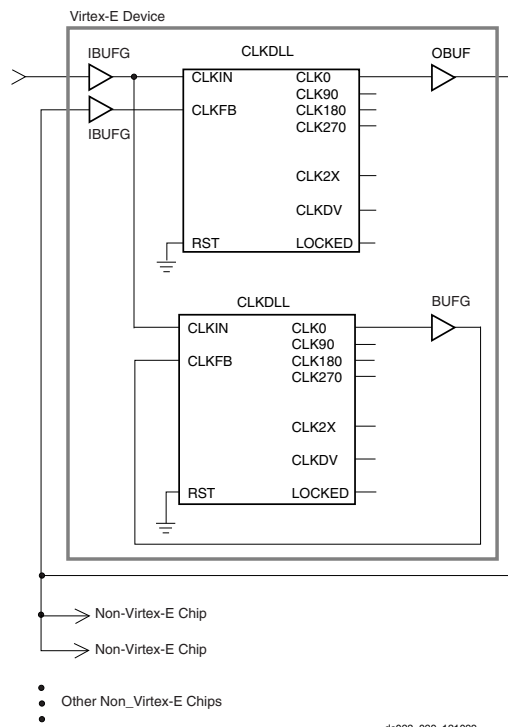

Figure 28: DLL De-skew of Board Level Clock

Board-level de-skew is not required for low-fanout clock networks. It is recommended for systems that have fanout limitations on the clock network, or if the clock distribution chip cannot handle the load.

Do not use the DLL output clock signals until after activation of the LOCKED signal. Prior to the activation of the LOCKED signal, the DLL output clocks are not valid and can exhibit glitches, spikes, or other spurious movement.

The dll_mirror_1 files in the xapp132.zip file show the VHDL and Verilog implementation of this circuit.

De-Skew of Clock and Its 2x Multiple

The circuit shown in Figure 29 implements a 2x clock multiplier and also uses the CLK0 clock output with zero ns skew between registers on the same chip. A clock divider circuit could alternatively be implemented using similar connections.

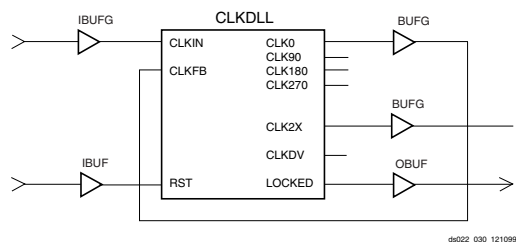

Figure 29: DLL De-skew of Clock and 2x Multiple

Because any single DLL can access only two BUFs at most, any additional output clock signals must be routed from the DLL in this example on the high speed backbone routing.

The dll_2x files in the xapp132.zip file show the VHDL and Verilog implementation of this circuit.

Virtex-E 4x Clock

Two DLLs located in the same half-edge (top-left, top-right, bottom-right, bottom-left) can be connected together, without using a BUFG between the CLKDLLs, to generate a 4x clock as shown in Figure 30. Virtex-E devices, like the Virtex devices, have four clock networks that are available for internal de-skewing of the clock. Each of the eight DLLs have access to two of the four clock networks. Although all the DLLs can be used for internal de-skewing, the presence of two GCLKBUFs on the top and two on the bottom indicate that only two of the four DLLs on the top (and two of the four DLLs on the bottom) can be used for this purpose.

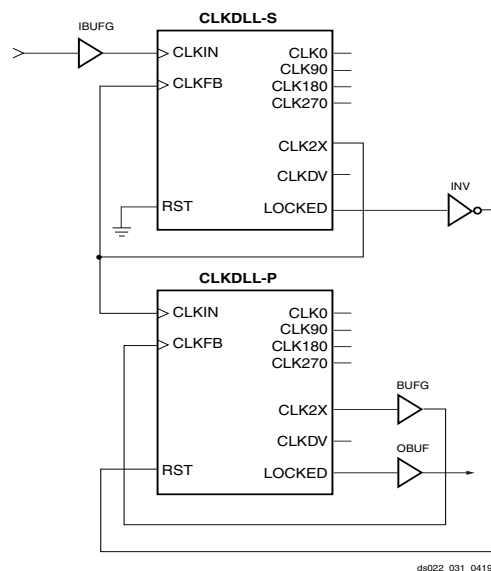

Figure 30: DLL Generation of 4x Clock in Virtex-E Devices

The dll_4xe files in the xapp 32.zip file show the DLL implementation in Verilog for Virtex-E devices. These files can be found at:

<ftp://ftp.xilinx.com/pub/applications/xapp/xapp132.zip>

Using Block SelectRAM+ Features

The Virtex FPGA Series provides dedicated blocks of on-chip, true dual-read/write port synchronous RAM, with 4096 memory cells. Each port of the block SelectRAM+ memory can be independently configured as a read/write port, a read port, a write port, and can be configured to a specific data width. block SelectRAM+ memory offers new capabilities, allowing FPGA designers to simplify designs.

Operating Modes

Virtex-E block SelectRAM+ memory supports two operating modes.

- Read Through
- Write Back

Read Through (one clock edge)

The read address is registered on the read port clock edge and data appears on the output after the RAM access time. Some memories might place the latch/register at the outputs, depending on the desire to have a faster clock-to-out versus set-up time. This is generally considered to be an inferior solution, since it changes the read operation to an asynchronous function with the possibility of missing an address/control line transition during the generation of the read pulse clock.

Write Back (one clock edge)

The write address is registered on the write port clock edge and the data input is written to the memory and mirrored on the output.

Block SelectRAM+ Characteristics

1. All inputs are registered with the port clock and have a set-up to clock timing specification.
2. All outputs have a read through or write back function depending on the state of the port WE pin. The outputs relative to the port clock are available after the clock-to-out timing specification.
3. The block SelectRAM elements are true SRAM memories and do not have a combinatorial path from the address to the output. The LUT SelectRAM+ cells in the CLBs are still available with this function.
4. The ports are completely independent from each other (*i.e.*, clocking, control, address, read/write function, and data width) without arbitration.
5. A write operation requires only one clock edge.
6. A read operation requires only one clock edge.

The output ports are latched with a self-timed circuit to guarantee a glitch-free read. The state of the output port does not change until the port executes another read or write operation.

Library Primitives

Figure 31 and Figure 32 show the two generic library block SelectRAM+ primitives. Table 14 describes all of the available primitives for synthesis and simulation.

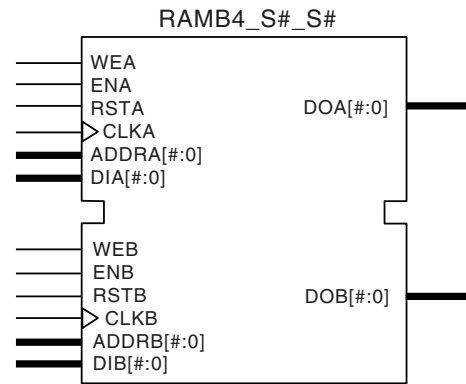

ds022_032_121399

Figure 31: Dual-Port Block SelectRAM+ Memory

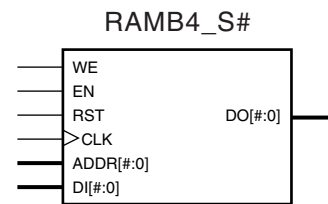

ds022_033_121399

Figure 32: Single-Port Block SelectRAM+ Memory

Table 14: Available Library Primitives

Primitive	Port A Width	Port B Width
RAMB4_S1	1	N/A
RAMB4_S1_S1		1
RAMB4_S1_S2		2
RAMB4_S1_S4		4
RAMB4_S1_S8		8
RAMB4_S1_S16		16
RAMB4_S2	2	N/A
RAMB4_S2_S2		2
RAMB4_S2_S4		4
RAMB4_S2_S8		8
RAMB4_S2_S16		16
RAMB4_S4	4	N/A
RAMB4_S4_S4		4
RAMB4_S4_S8		8
RAMB4_S4_S16		16
RAMB4_S8	8	N/A
RAMB4_S8_S8		8
RAMB4_S8_S16		16
RAMB4_S16	16	N/A
RAMB4_S16_S16		16

Port Signals

Each block SelectRAM+ port operates independently of the others while accessing the same set of 4096 memory cells.

Table 15 describes the depth and width aspect ratios for the block SelectRAM+ memory.

Table 15: Block SelectRAM+ Port Aspect Ratios

Width	Depth	ADDR Bus	Data Bus
1	4096	ADDR<11:0>	DATA<0>
2	2048	ADDR<10:0>	DATA<1:0>
4	1024	ADDR<9:0>	DATA<3:0>
8	512	ADDR<8:0>	DATA<7:0>
16	256	ADDR<7:0>	DATA<15:0>

Clock—CLK[AIB]

Each port is fully synchronous with independent clock pins. All port input pins have setup time referenced to the port CLK pin. The data output bus has a clock-to-out time referenced to the CLK pin.

Enable—EN[AIB]

The enable pin affects the read, write and reset functionality of the port. Ports with an inactive enable pin keep the output pins in the previous state and do not write data to the memory cells.

Write Enable—WE[AIB]

Activating the write enable pin allows the port to write to the memory cells. When active, the contents of the data input bus are written to the RAM at the address pointed to by the address bus, and the new data also reflects on the data out bus. When inactive, a read operation occurs and the contents of the memory cells referenced by the address bus reflect on the data out bus.

Reset—RST[AIB]

The reset pin forces the data output bus latches to zero synchronously. This does not affect the memory cells of the RAM and does not disturb a write operation on the other port.

Address Bus—ADDR[AIB]<#:0>

The address bus selects the memory cells for read or write. The width of the port determines the required width of this bus as shown in **Table 15**.

Data In Bus—DI[AIB]<#:0>

The data in bus provides the new data value to be written into the RAM. This bus and the port have the same width, as shown in **Table 15**.

Data Output Bus—DO[AIB]<#:0>

The data out bus reflects the contents of the memory cells referenced by the address bus at the last active clock edge. During a write operation, the data out bus reflects the data in bus. The width of this bus equals the width of the port. The allowed widths appear in **Table 15**.

Inverting Control Pins

The four control pins (CLK, EN, WE and RST) for each port have independent inversion control as a configuration option.

Address Mapping

Each port accesses the same set of 4096 memory cells using an addressing scheme dependent on the width of the port. The physical RAM location addressed for a particular width are described in the following formula (of interest only when the two ports use different aspect ratios).

$$\text{Start} = ((\text{ADDR}_{\text{port}} + 1) * \text{Width}_{\text{port}}) - 1$$

$$\text{End} = \text{ADDR}_{\text{port}} * \text{Width}_{\text{port}}$$

Table 16 shows low order address mapping for each port width.

Table 16: Port Address Mapping

Port Width	Port Addresses																
1	4095...	15	14	13	12	11	10	9	8	7	6	5	4	3	2	1	0
2	2047...	07	06	05	04	03	02	01	00								
4	1023...	03		02		01		00									
8	511...	01				00											
16	255...	00															

Creating Larger RAM Structures

The block SelectRAM+ columns have specialized routing to allow cascading blocks together with minimal routing delays. This achieves wider or deeper RAM structures with a smaller timing penalty than when using normal routing channels.

Location Constraints

Block SelectRAM+ instances can have LOC properties attached to them to constrain the placement. The block SelectRAM+ placement locations are separate from the CLB location naming convention, allowing the LOC properties to transfer easily from array to array.

The LOC properties use the following form.

$$\text{LOC} = \text{RAMB4_R\#C\#}$$

RAMB4_R0C0 is the upper left RAMB4 location on the device.

Conflict Resolution

The block SelectRAM+ memory is a true dual-read/write port RAM that allows simultaneous access of the same memory cell from both ports. When one port writes to a given memory cell, the other port must not address that memory cell (for a write or a read) within the clock-to-clock setup window. The following lists specifics of port and memory cell write conflict resolution.

- If both ports write to the same memory cell simultaneously, violating the clock-to-clock setup requirement, consider the data stored as invalid.
- If one port attempts a read of the same memory cell the other simultaneously writes, violating the clock-to-clock setup requirement, the following occurs.
 - The write succeeds
 - The data out on the writing port accurately reflects the data written.
 - The data out on the reading port is invalid.

Conflicts do not cause any physical damage.

Single Port Timing

Figure 33 shows a timing diagram for a single port of a block SelectRAM+ memory. The block SelectRAM+ AC switching characteristics are specified in the data sheet. The block SelectRAM+ memory is initially disabled.

At the first rising edge of the CLK pin, the ADDR, DI, EN, WE, and RST pins are sampled. The EN pin is High and the WE pin is Low indicating a read operation. The DO bus contains the contents of the memory location, 0x00, as indicated by the ADDR bus.

At the second rising edge of the CLK pin, the ADDR, DI, EN, WR, and RST pins are sampled again. The EN and WE pins are High indicating a write operation. The DO bus mirrors the DI bus. The DI bus is written to the memory location 0x0F.

At the third rising edge of the CLK pin, the ADDR, DI, EN, WR, and RST pins are sampled again. The EN pin is High

and the WE pin is Low indicating a read operation. The DO bus contains the contents of the memory location 0x7E as indicated by the ADDR bus.

At the fourth rising edge of the CLK pin, the ADDR, DI, EN, WR, and RST pins are sampled again. The EN pin is Low indicating that the block SelectRAM+ memory is now disabled. The DO bus retains the last value.

Dual Port Timing

Figure 34 shows a timing diagram for a true dual-port read/write block SelectRAM+ memory. The clock on port A has a longer period than the clock on Port B. The timing parameter T_{BCCS} , (clock-to-clock set-up) is shown on this diagram. The parameter, T_{BCCS} is violated once in the diagram. All other timing parameters are identical to the single port version shown in Figure 33.

T_{BCCS} is only of importance when the address of both ports are the same and at least one port is performing a write operation. When the clock-to-clock set-up parameter is violated for a WRITE-WRITE condition, the contents of the memory at that location are invalid. When the clock-to-clock set-up parameter is violated for a WRITE-READ condition, the contents of the memory are correct, but the read port has invalid data. At the first rising edge of CLKA, memory location 0x00 is to be written with the value 0xAAAA and is mirrored on the DOA bus. The last operation of Port B was a read to the same memory location 0x00. The DOB bus of Port B does not change with the new value on Port A, and retains the last read value. A short time later, Port B executes another read to memory location 0x00, and the DOB bus now reflects the new memory value written by Port A.

At the second rising edge of CLKA, memory location 0x7E is written with the value 0x9999 and is mirrored on the DOA bus. Port B then executes a read operation to the same memory location without violating the T_{BCCS} parameter and the DOB reflects the new memory values written by Port A.

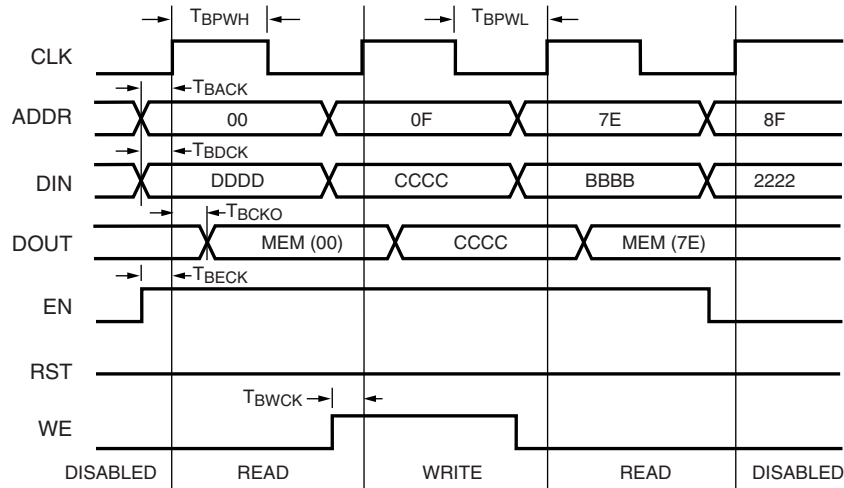

ds022_0343_121399

Figure 33: Timing Diagram for Single Port Block SelectRAM+ Memory

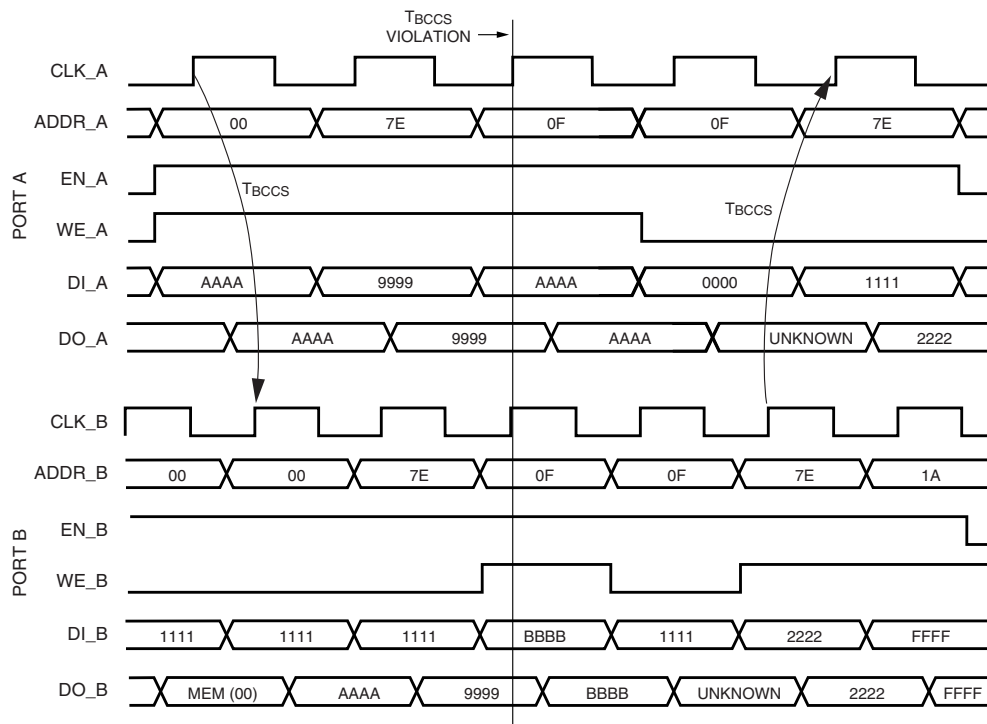

ds022_035_121399

Figure 34: Timing Diagram for a True Dual-port Read/Write Block SelectRAM+ Memory

At the third rising edge of CLKA, the T_{BCCS} parameter is violated with two writes to memory location 0x0F. The DOA and DOB busses reflect the contents of the DIA and DIB busses, but the stored value at 0x0F is invalid.

At the fourth rising edge of CLKA, a read operation is performed at memory location 0x0F and invalid data is present

on the DOA bus. Port B also executes a read operation to memory location 0x0F and also reads invalid data.

At the fifth rising edge of CLKA a read operation is performed that does not violate the T_{BCCS} parameter to the previous write of 0x7E by Port B. The DOA bus reflects the recently written value by Port B.

Initialization

The block SelectRAM+ memory can initialize during the device configuration sequence. The 16 initialization properties of 64 hex values each (a total of 4096 bits) set the initialization of each RAM. These properties appear in [Table 17](#). Any initialization properties not explicitly set configure as zeros. Partial initialization strings pad with zeros. Initialization strings greater than 64 hex values generate an error. The RAMs can be simulated with the initialization values using generics in VHDL simulators and parameters in Verilog simulators.

Initialization in VHDL and Synopsys

The block SelectRAM+ structures can be initialized in VHDL for both simulation and synthesis for inclusion in the EDIF output file. The simulation of the VHDL code uses a generic to pass the initialization. Synopsys FPGA compiler does not presently support generics. The initialization values instead attach as attributes to the RAM by a built-in Synopsys `dc_script`. The `translate_off` statement stops synthesis translation of the generic statements. The following code illustrates a module that employs these techniques.

Table 17: RAM Initialization Properties

Property	Memory Cells
INIT_00	255 to 0
INIT_01	511 to 256
INIT_02	767 to 512
INIT_03	1023 to 768
INIT_04	1279 to 1024
INIT_05	1535 to 1280
INIT_06	1791 to 2047
INIT_07	2047 to 1792
INIT_08	2303 to 2048
INIT_09	2559 to 2304
INIT_0a	2815 to 2560
INIT_0b	3071 to 2816
INIT_0c	3327 to 3072
INIT_0d	3583 to 3328
INIT_0e	3839 to 3584
INIT_0f	4095 to 3840

Initialization in Verilog and Synopsys

The block SelectRAM+ structures can be initialized in Verilog for both simulation and synthesis for inclusion in the EDIF output file. The simulation of the Verilog code uses a `defparam` to pass the initialization. The Synopsys FPGA compiler does not presently support `defparam`. The initialization values instead attach as attributes to the RAM by a built-in Synopsys `dc_script`. The `translate_off` statement stops synthesis translation of the `defparam` statements. The following code illustrates a module that employs these techniques.

Design Examples

Creating a 32-bit Single-Port RAM

The true dual-read/write port functionality of the block SelectRAM+ memory allows a single port, 128 deep by 32-bit wide RAM to be created using a single block SelectRAM+ cell as shown in [Table 35](#).

Interleaving the memory space, setting the LSB of the address bus of Port A to 1 (V_{CC}), and the LSB of the address bus of Port B to 0 (GND), allows a 32-bit wide single port RAM to be created.

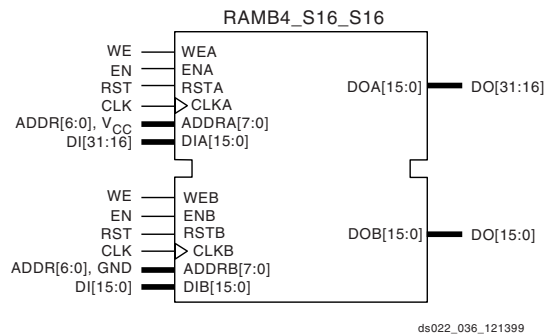

Figure 35: Single Port 128 x 32 RAM

Creating Two Single-Port RAMs

The true dual-read/write port functionality of the block SelectRAM+ memory allows a single RAM to be split into two single port memories of 2K bits each as shown in [Figure 36](#).

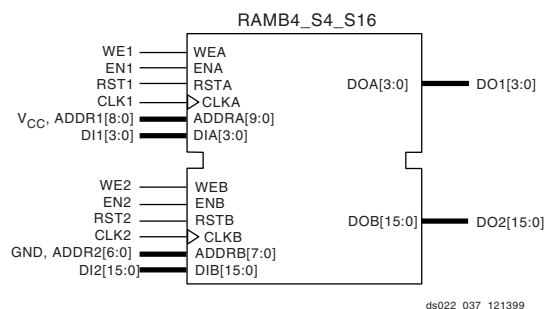

Figure 36: 512 x 4 RAM and 128 x 16 RAM

In this example, a 512K x 4 RAM (Port A) and a 128 x 16 RAM (Port B) are created out of a single block SelectRAM+. The address space for the RAM is split by fixing the MSB of Port A to 1 (V_{CC}) for the upper 2K bits and the MSB of Port B to 0 (GND) for the lower 2K bits.

Block Memory Generation

The CoreGen program generates memory structures using the block SelectRAM+ features. This program outputs VHDL or Verilog simulation code templates and an EDIF file for inclusion in a design.

Verilog Initialization Example

```
module MYMEM (CLK, WE, ADDR, DIN, DOUT);
input CLK, WE;
input [8:0] ADDR;
input [7:0] DIN;
output [7:0] DOUT;

wire logic0, logic1;

//synopsys dc_script_begin
//set_attribute ram0 INIT_00
"0123456789ABCDEF0123456789ABCDEF0123456789ABCDEF0123456789ABCDEF" -type string
//set_attribute ram0 INIT_01
"FEDCBA9876543210FEDCBA9876543210FEDCBA9876543210FEDCBA9876543210" -type string
//synopsys dc_script_end

assign logic0 = 1'b0;
assign logic1 = 1'b1;

RAMB4_S8 ram0 (.WE(WE), .EN(logic1), .RST(logic0), .CLK(CLK), .ADDR(ADDR), .DI(DIN),
.DO(DOUT));
//synopsys translate_off
defparam ram0.INIT_00 =
256h'0123456789ABCDEF0123456789ABCDEF0123456789ABCDEF0123456789ABCDEF;
defparam ram0.INIT_01 =
256h'FEDCBA9876543210FEDCBA9876543210FEDCBA9876543210FEDCBA9876543210;
//synopsys translate_on
endmodule
```

Using SelectI/O

The Virtex-E FPGA series includes a highly configurable, high-performance I/O resource, called SelectI/O™ to provide support for a wide variety of I/O standards. The SelectI/O resource is a robust set of features including programmable control of output drive strength, slew rate, and input delay and hold time. Taking advantage of the flexibility and SelectI/O features and the design considerations described in this document can improve and simplify system level design.

Introduction

As FPGAs continue to grow in size and capacity, the larger and more complex systems designed for them demand an increased variety of I/O standards. Furthermore, as system clock speeds continue to increase, the need for high performance I/O becomes more important. While chip-to-chip delays have an increasingly substantial impact on overall system speed, the task of achieving the desired system performance becomes more difficult with the proliferation of low-voltage I/O standards.

SelectI/O, the revolutionary input/output resource of Virtex-E devices, has resolved this potential problem by providing a highly configurable, high-performance alternative to the I/O resources of more conventional programmable devices. The Virtex-E SelectI/O features combine the flexibility and time-to-market advantages of programmable logic

with the high performance previously available only with ASICs and custom ICs.

Each SelectI/O block can support up to 20 I/O standards. Supporting such a variety of I/O standards allows the support of a wide variety of applications, from general purpose standard applications to high-speed low-voltage memory busses.

SelectI/O blocks also provide selectable output drive strengths and programmable slew rates for the LVTTTL output buffers, as well as an optional, programmable weak pull-up, weak pull-down, or weak “keeper” circuit ideal for use in external bussing applications.

Each input/output block (IOB) includes three registers, one each for the input, output, and 3-state signals within the IOB. These registers are optionally configurable as either a D-type flip-flop or as a level sensitive latch.

The input buffer has an optional delay element used to guarantee a zero hold time requirement for input signals registered within the IOB.

The Virtex-E SelectI/O features also provide dedicated resources for input reference voltage (V_{REF}) and output source voltage (V_{CCO}), along with a convenient banking system that simplifies board design.

By taking advantage of the built-in features and wide variety of I/O standards supported by the SelectI/O features, system-level design and board design can be greatly simplified and improved.

Fundamentals

Modern bus applications, pioneered by the largest and most influential companies in the digital electronics industry, are commonly introduced with a new I/O standard tailored specifically to the needs of that application. The bus I/O standards provide specifications to other vendors who create products designed to interface with these applications. Each standard often has its own specifications for current, voltage, I/O buffering, and termination techniques.

The ability to provide the flexibility and time-to-market advantages of programmable logic is increasingly dependent on the capability of the programmable logic device to support an ever increasing variety of I/O standards

The SelectI/O resources feature highly configurable input and output buffers which provide support for a wide variety of I/O standards. As shown in [Table 18](#), each buffer type can support a variety of voltage requirements.

Table 18: Virtex-E Supported I/O Standards

I/O Standard	Output V _{CCO}	Input V _{CCO}	Input V _{REF}	Board Termination Voltage (V _{TT})
LVTTTL	3.3	3.3	N/A	N/A
LVC MOS2	2.5	2.5	N/A	N/A
LVC MOS18	1.8	1.8	N/A	N/A
SSTL3 I & II	3.3	N/A	1.50	1.50
SSTL2 I & II	2.5	N/A	1.25	1.25
GTL	N/A	N/A	0.80	1.20
GTL+	N/A	N/A	1.0	1.50
HSTL I	1.5	N/A	0.75	0.75
HSTL III & IV	1.5	N/A	0.90	1.50
CTT	3.3	N/A	1.50	1.50
AGP-2X	3.3	N/A	1.32	N/A
PCI33_3	3.3	3.3	N/A	N/A
PCI66_3	3.3	3.3	N/A	N/A
BLVDS & LVDS	2.5	N/A	N/A	N/A
LVPECL	3.3	N/A	N/A	N/A

Overview of Supported I/O Standards

This section provides a brief overview of the I/O standards supported by all Virtex-E devices.

While most I/O standards specify a range of allowed voltages, this document records typical voltage values only. Detailed information on each specification can be found on the Electronic Industry Alliance Jeduc website at:

<http://www.jedec.org>

LVTTTL — Low-Voltage TTL

The Low-Voltage TTL, or LVTTTL standard is a general purpose EIA/JESDSA standard for 3.3 V applications that uses an LVTTTL input buffer and a Push-Pull output buffer. This standard requires a 3.3 V output source voltage (V_{CCO}), but does not require the use of a reference voltage (V_{REF}) or a termination voltage (V_{TT}).

LVC MOS2 — Low-Voltage CMOS for 2.5 Volts

The Low-Voltage CMOS for 2.5 Volts or lower, or LVC MOS2 standard is an extension of the LVC MOS standard (JESD 8.-5) used for general purpose 2.5 V applications. This standard requires a 2.5 V output source voltage (V_{CCO}), but does not require the use of a reference voltage (V_{REF}) or a board termination voltage (V_{TT}).

LVC MOS18 — 1.8 V Low Voltage CMOS

This standard is an extension of the LVC MOS standard. It is used in general purpose 1.8 V applications. The use of a reference voltage (V_{REF}) or a board termination voltage (V_{TT}) is not required.

PCI — Peripheral Component Interface

The Peripheral Component Interface, or PCI standard specifies support for both 33 MHz and 66 MHz PCI bus applications. It uses a LVTTTL input buffer and a Push-Pull output buffer. This standard does not require the use of a reference voltage (V_{REF}) or a board termination voltage (V_{TT}), however, it does require a 3.3 V output source voltage (V_{CCO}).

GTL — Gunning Transceiver Logic Terminated

The Gunning Transceiver Logic, or GTL standard is a high-speed bus standard (JESD8.3) invented by Xerox. Xilinx has implemented the terminated variation for this standard. This standard requires a differential amplifier input buffer and a Open Drain output buffer.

GTL+ — Gunning Transceiver Logic Plus

The Gunning Transceiver Logic Plus, or GTL+ standard is a high-speed bus standard (JESD8.3) first used by the Pentium Pro processor.

HSTL — High-Speed Transceiver Logic

The High-Speed Transceiver Logic, or HSTL standard is a general purpose high-speed, 1.5 V bus standard sponsored by IBM (EIA/JESD 8-6). This standard has four variations or classes. SelectI/O devices support Class I, III, and IV. This

standard requires a Differential Amplifier input buffer and a Push-Pull output buffer.

SSTL3 — Stub Series Terminated Logic for 3.3V

The Stub Series Terminated Logic for 3.3 V, or SSTL3 standard is a general purpose 3.3 V memory bus standard also sponsored by Hitachi and IBM (JESD8-8). This standard has two classes, I and II. SelectI/O devices support both classes for the SSTL3 standard. This standard requires a Differential Amplifier input buffer and an Push-Pull output buffer.

SSTL2 — Stub Series Terminated Logic for 2.5V

The Stub Series Terminated Logic for 2.5 V, or SSTL2 standard is a general purpose 2.5 V memory bus standard sponsored by Hitachi and IBM (JESD8-9). This standard has two classes, I and II. SelectI/O devices support both classes for the SSTL2 standard. This standard requires a Differential Amplifier input buffer and an Push-Pull output buffer.

CTT — Center Tap Terminated

The Center Tap Terminated, or CTT standard is a 3.3 V memory bus standard sponsored by Fujitsu (JESD8-4). This standard requires a Differential Amplifier input buffer and a Push-Pull output buffer.

AGP-2X — Advanced Graphics Port

The Intel AGP standard is a 3.3 V Advanced Graphics Port-2X bus standard used with the Pentium II processor for graphics applications. This standard requires a Push-Pull output buffer and a Differential Amplifier input buffer.

LVDS — Low Voltage Differential Signal

LVDS is a differential I/O standard. It requires that one data bit is carried through two signal lines. As with all differential signaling standards, LVDS has an inherent noise immunity over single-ended I/O standards. The voltage swing between two signal lines is approximately 350 mV. The use of a reference voltage (V_{REF}) or a board termination voltage (V_{TT}) is not required. LVDS requires the use of two pins per input or output. LVDS requires external resistor termination.

BLVDS — Bus LVDS

This standard allows for bidirectional LVDS communication between two or more devices. The external resistor termination is different than the one for standard LVDS.

LVPECL — Low Voltage Positive Emitter Coupled Logic

LVPECL is another differential I/O standard. It requires two signal lines for transmitting one data bit. This standard specifies two pins per input or output. The voltage swing between these two signal lines is approximately 850 mV. The use of a reference voltage (V_{REF}) or a board termination voltage (V_{TT}) is not required. The LVPECL standard requires external resistor termination.

Library Symbols

The Xilinx library includes an extensive list of symbols designed to provide support for the variety of SelectI/O features. Most of these symbols represent variations of the five generic SelectI/O symbols.

- IBUF (input buffer)
- IBUG (global clock input buffer)
- OBUF (output buffer)
- OBUFT (3-state output buffer)
- IOBUF (input/output buffer)

IBUF

Signals used as inputs to the Virtex-E device must source an input buffer (IBUF) via an external input port. The generic Virtex-E IBUF symbol appears in Figure 37. The extension to the base name defines which I/O standard the IBUF uses. The assumed standard is LVTTTL when the generic IBUF has no specified extension.

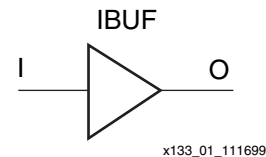

Figure 37: Input Buffer (IBUF) Symbols

The following list details the variations of the IBUF symbol:

- IBUF
- IBUF_LVCMOS2
- IBUF_PCI33_3
- IBUF_PCI66_3
- IBUF_GTL
- IBUF_GTLP
- IBUF_HSTL_I
- IBUF_HSTL_III
- IBUF_HSTL_IV
- IBUF_SSTL3_I
- IBUF_SSTL3_II
- IBUF_SSTL2_I
- IBUF_SSTL2_II
- IBUF_CTT
- IBUF_AGP
- IBUF_LVCMOS18
- IBUF_LVDS
- IBUF_LVPECL

When the IBUF symbol supports an I/O standard that requires a V_{REF} , the IBUF automatically configures as a differential amplifier input buffer. The V_{REF} voltage must be supplied on the V_{REF} pins. In the case of LVDS, LVPECL, and BLVDS, V_{REF} is not required.

The voltage reference signal is “banked” within the Virtex-E device on a half-edge basis such that for all packages there are eight independent V_{REF} banks internally. See [Figure 38](#) for a representation of the Virtex-E I/O banks. Within each bank approximately one of every six I/O pins is automatically configured as a V_{REF} input. After placing a differential amplifier input signal within a given V_{REF} bank, the same external source must drive all I/O pins configured as a V_{REF} input.

IBUF placement restrictions require that any differential amplifier input signals within a bank be of the same standard. How to specify a specific location for the IBUF via the LOC property is described below. [Table 19](#) summarizes the Virtex-E input standards compatibility requirements.

An optional delay element is associated with each IBUF. When the IBUF drives a flip-flop within the IOB, the delay element by default activates to ensure a zero hold-time requirement. The NODELAY=TRUE property overrides this default.

When the IBUF does not drive a flip-flop within the IOB, the delay element de-activates by default to provide higher performance. To delay the input signal, activate the delay element with the DELAY=TRUE property.

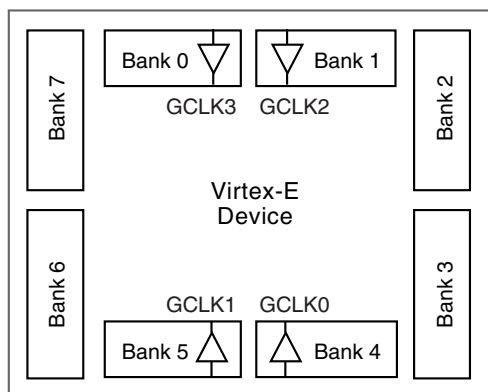

ds022_42_012100

Figure 38: Virtex-E I/O Banks

Table 19: Xilinx Input Standards Compatibility Requirements

Rule 1	Standards with the same input V_{CCO} , output V_{CCO} , and V_{REF} can be placed within the same bank.
--------	--

IBUFG

Signals used as high fanout clock inputs to the Virtex-E device should drive a global clock input buffer (IBUFG) via an external input port in order to take advantage of one of the four dedicated global clock distribution networks. The output of the IBUFG should only drive a CLKDLL, CLK-

DLLHF, or a BUFG symbol. The generic Virtex-E IBUFG symbol appears in [Figure 39](#).

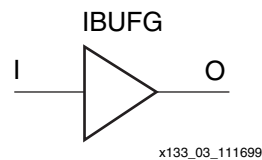

Figure 39: Virtex-E Global Clock Input Buffer (IBUFG) Symbol

The extension to the base name determines which I/O standard is used by the IBUFG. With no extension specified for the generic IBUFG symbol, the assumed standard is LVTTTL.

The following list details variations of the IBUFG symbol.

- IBUFG
- IBUFG_LVCMOS2
- IBUFG_PCI33_3
- IBUFG_PCI66_3
- IBUFG_GTL
- IBUFG_GTLP
- IBUFG_HSTL_I
- IBUFG_HSTL_III
- IBUFG_HSTL_IV
- IBUFG_SSTL3_I
- IBUFG_SSTL3_II
- IBUFG_SSTL2_I
- IBUFG_SSTL2_II
- IBUFG_CTT
- IBUFG_AGP
- IBUFG_LVCMOS18
- IBUFG_LVDS
- IBUFG_LVPECL

When the IBUFG symbol supports an I/O standard that requires a differential amplifier input, the IBUFG automatically configures as a differential amplifier input buffer. The low-voltage I/O standards with a differential amplifier input require an external reference voltage input V_{REF}

The voltage reference signal is “banked” within the Virtex-E device on a half-edge basis such that for all packages there are eight independent V_{REF} banks internally. See [Figure 38](#) for a representation of the Virtex-E I/O banks. Within each bank approximately one of every six I/O pins is automatically configured as a V_{REF} input. After placing a differential amplifier input signal within a given V_{REF} bank, the same external source must drive all I/O pins configured as a V_{REF} input.

IBUFG placement restrictions require any differential amplifier input signals within a bank be of the same standard. The LOC property can specify a location for the IBUFG.

As an added convenience, the BUFGP can be used to instantiate a high fanout clock input. The BUFGP symbol represents a combination of the LVTTTL IBUFG and BUFG symbols, such that the output of the BUFGP can connect directly to the clock pins throughout the design.

Unlike previous architectures, the Virtex-E BUFGP symbol can only be placed in a global clock pad location. The LOC property can specify a location for the BUFGP.

OBUF

An OBUF must drive outputs through an external output port. The generic output buffer (OBUF) symbol appears in Figure 40.

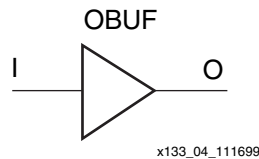

Figure 40: Virtex-E Output Buffer (OBUF) Symbol

The extension to the base name defines which I/O standard the OBUF uses. With no extension specified for the generic OBUF symbol, the assumed standard is slew rate limited LVTTTL with 12 mA drive strength.

The LVTTTL OBUF additionally can support one of two slew rate modes to minimize bus transients. By default, the slew rate for each output buffer is reduced to minimize power bus transients when switching non-critical signals.

LVTTTL output buffers have selectable drive strengths.

The format for LVTTTL OBUF symbol names is as follows.

OBUF_<slew_rate>_<drive_strength>

<slew_rate> is either F (Fast), or S (Slow) and <drive_strength> is specified in milliamps (2, 4, 6, 8, 12, 16, or 24).

The following list details variations of the OBUF symbol.

- OBUF
- OBUF_S_2
- OBUF_S_4
- OBUF_S_6
- OBUF_S_8
- OBUF_S_12
- OBUF_S_16
- OBUF_S_24
- OBUF_F_2
- OBUF_F_4
- OBUF_F_6
- OBUF_F_8
- OBUF_F_12
- OBUF_F_16

- OBUF_F_24
- OBUF_LVCMOS2
- OBUF_PCI33_3
- OBUF_PCI66_3
- OBUF_GTL
- OBUF_GTLP
- OBUF_HSTL_I
- OBUF_HSTL_III
- OBUF_HSTL_IV
- OBUF_SSTL3_I
- OBUF_SSTL3_II
- OBUF_SSTL2_I
- OBUF_SSTL2_II
- OBUF_CTT
- OBUF_AGP
- OBUF_LVCMOS18
- OBUF_LVDS
- OBUF_LVPECL

The Virtex-E series supports eight banks for the HQ and PQ packages. The CS packages support four V_{CCO} banks.

OBUF placement restrictions require that within a given V_{CCO} bank each OBUF share the same output source drive voltage. Input buffers of any type and output buffers that do not require V_{CCO} can be placed within any V_{CCO} bank.

Table 20 summarizes the Virtex-E output compatibility requirements. The LOC property can specify a location for the OBUF.

Table 20: Output Standards Compatibility Requirements

Rule 1	Only outputs with standards that share compatible V _{CCO} can be used within the same bank.
Rule 2	There are no placement restrictions for outputs with standards that do not require a V _{CCO} .
V _{CCO}	Compatible Standards
3.3	LVTTTL, SSTL3_I, SSTL3_II, CTT, AGP, GTL, GTL+, PCI33_3, PCI66_3
2.5	SSTL2_I, SSTL2_II, LVCMOS2, GTL, GTL+
1.5	HSTL_I, HSTL_III, HSTL_IV, GTL, GTL+

OBUFT

The generic 3-state output buffer OBUFT, shown in Figure 41, typically implements 3-state outputs or bidirectional I/O.

The extension to the base name defines which I/O standard OBUFT uses. With no extension specified for the generic OBUFT symbol, the assumed standard is slew rate limited LVTTTL with 12 mA drive strength.

The LVTTTL OBUFT additionally can support one of two slew rate modes to minimize bus transients. By default, the slew rate for each output buffer is reduced to minimize power bus transients when switching non-critical signals.

LVTTTL 3-state output buffers have selectable drive strengths.

The format for LVTTTL OBUFT symbol names is as follows.

OBUFT_<slew_rate>_<drive_strength>

<slew_rate> can be either F (Fast), or S (Slow) and <drive_strength> is specified in milliamps (2, 4, 6, 8, 12, 16, or 24).

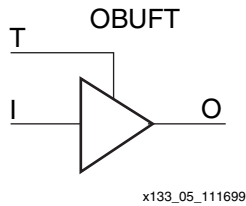

Figure 41: 3-State Output Buffer Symbol (OBUFT)

The following list details variations of the OBUFT symbol.

- OBUFT
- OBUFT_S_2
- OBUFT_S_4
- OBUFT_S_6
- OBUFT_S_8
- OBUFT_S_12
- OBUFT_S_16
- OBUFT_S_24
- OBUFT_F_2
- OBUFT_F_4
- OBUFT_F_6
- OBUFT_F_8
- OBUFT_F_12
- OBUFT_F_16
- OBUFT_F_24
- OBUFT_LVCMOS2
- OBUFT_PCI33_3
- OBUFT_PCI66_3
- OBUFT_GTL
- OBUFT_GTLP
- OBUFT_HSTL_I
- OBUFT_HSTL_III
- OBUFT_HSTL_IV
- OBUFT_SSTL3_I
- OBUFT_SSTL3_II
- OBUFT_SSTL2_I
- OBUFT_SSTL2_II
- OBUFT_CTT
- OBUFT_AGP
- OBUFT_LVCMOS18
- OBUFT_LVDS
- OBUFT_LVPECL

The Virtex-E series supports eight banks for the HQ and PQ packages. The CS package supports four V_{CCO} banks.

The SelectI/O OBUFT placement restrictions require that within a given V_{CCO} bank each OBUFT share the same output source drive voltage. Input buffers of any type and output buffers that do not require V_{CCO} can be placed within the same V_{CCO} bank.

The LOC property can specify a location for the OBUFT.

3-state output buffers and bidirectional buffers can have either a weak pull-up resistor, a weak pull-down resistor, or a weak “keeper” circuit. Control this feature by adding the appropriate symbol to the output net of the OBUFT (PULLUP, PULLDOWN, or KEEPER).

The weak “keeper” circuit requires the input buffer within the IOB to sample the I/O signal. So, OBUFTs programmed for an I/O standard that requires a V_{REF} have automatic placement of a V_{REF} in the bank with an OBUFT configured with a weak “keeper” circuit. This restriction does not affect most circuit design as applications using an OBUFT configured with a weak “keeper” typically implement a bidirectional I/O. In this case the IBUF (and the corresponding V_{REF}) are explicitly placed.

The LOC property can specify a location for the OBUFT.

IOBUF

Use the IOBUF symbol for bidirectional signals that require both an input buffer and a 3-state output buffer with an active high 3-state pin. The generic input/output buffer IOBUF appears in [Figure 42](#).

The extension to the base name defines which I/O standard the IOBUF uses. With no extension specified for the generic IOBUF symbol, the assumed standard is LVTTTL input buffer and slew rate limited LVTTTL with 12 mA drive strength for the output buffer.

The LVTTTL IOBUF additionally can support one of two slew rate modes to minimize bus transients. By default, the slew rate for each output buffer is reduced to minimize power bus transients when switching non-critical signals.

LVTTTL bidirectional buffers have selectable output drive strengths.

The format for LVTTTL IOBUF symbol names is as follows.

IOBUF_<slew_rate>_<drive_strength>

<slew_rate> can be either F (Fast), or S (Slow) and <drive_strength> is specified in milliamps (2, 4, 6, 8, 12, 16, or 24).

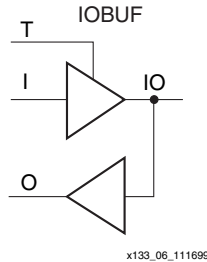

Figure 42: Input/Output Buffer Symbol (IOBUF)

The following list details variations of the IOBUF symbol.

- IOBUF
- IOBUF_S_2
- IOBUF_S_4
- IOBUF_S_6
- IOBUF_S_8
- IOBUF_S_12
- IOBUF_S_16
- IOBUF_S_24
- IOBUF_F_2
- IOBUF_F_4
- IOBUF_F_6
- IOBUF_F_8
- IOBUF_F_12
- IOBUF_F_16
- IOBUF_F_24
- IOBUF_LVCMOS2
- IOBUF_PCI33_3
- IOBUF_PCI66_3
- IOBUF_GTL
- IOBUF_GTL_P
- IOBUF_HSTL_I
- IOBUF_HSTL_III
- IOBUF_HSTL_IV
- IOBUF_SSTL3_I
- IOBUF_SSTL3_II
- IOBUF_SSTL2_I
- IOBUF_SSTL2_II
- IOBUF_CTT
- IOBUF_AGP
- IOBUF_LVCMOS18
- IOBUF_LVDS
- IOBUF_LVPECL

When the IOBUF symbol used supports an I/O standard that requires a differential amplifier input, the IOBUF automatically configures with a differential amplifier input buffer. The low-voltage I/O standards with a differential amplifier input require an external reference voltage input V_{REF}

The voltage reference signal is “banked” within the Virtex-E device on a half-edge basis such that for all packages there are eight independent V_{REF} banks internally. See Figure 38 on page 34 for a representation of the Virtex-E I/O banks. Within each bank approximately one of every six I/O pins is automatically configured as a V_{REF} input. After placing a differential amplifier input signal within a given V_{REF} bank, the same external source must drive all I/O pins configured as a V_{REF} input.

IOBUF placement restrictions require any differential amplifier input signals within a bank be of the same standard.

The Virtex-E series supports eight banks for the HQ and PQ packages. The CS package supports four V_{CCO} banks.

Additional restrictions on the Virtex-E SelectI/O IOBUF placement require that within a given V_{CCO} bank each IOBUF must share the same output source drive voltage. Input buffers of any type and output buffers that do not require V_{CCO} can be placed within the same V_{CCO} bank. The LOC property can specify a location for the IOBUF.

An optional delay element is associated with the input path in each IOBUF. When the IOBUF drives an input flip-flop within the IOB, the delay element activates by default to ensure a zero hold-time requirement. Override this default with the NODELAY=TRUE property.

In the case when the IOBUF does not drive an input flip-flop within the IOB, the delay element de-activates by default to provide higher performance. To delay the input signal, activate the delay element with the DELAY=TRUE property.

3-state output buffers and bidirectional buffers can have either a weak pull-up resistor, a weak pull-down resistor, or a weak “keeper” circuit. Control this feature by adding the appropriate symbol to the output net of the IOBUF (PULLUP, PULLDOWN, or KEEPER).

SelectI/O Properties

Access to some of the SelectI/O features (for example, location constraints, input delay, output drive strength, and slew rate) is available through properties associated with these features.

Input Delay Properties

An optional delay element is associated with each IOBUF. When the IOBUF drives a flip-flop within the IOB, the delay element activates by default to ensure a zero hold-time requirement. Use the NODELAY=TRUE property to override this default.

In the case when the IOBUF does not drive a flip-flop within the IOB, the delay element by default de-activates to provide higher performance. To delay the input signal, activate the delay element with the DELAY=TRUE property.

IOB Flip-Flop/Latch Property

The Virtex-E series I/O block (IOB) includes an optional register on the input path, an optional register on the output path, and an optional register on the 3-state control pin. The design implementation software automatically takes advantage of these registers when the following option for the Map program is specified.

```
map -pr b <filename>
```

Alternatively, the IOB = TRUE property can be placed on a register to force the mapper to place the register in an IOB.

Location Constraints

Specify the location of each SelectI/O symbol with the location constraint LOC attached to the SelectI/O symbol. The external port identifier indicates the value of the location constrain. The format of the port identifier depends on the package chosen for the specific design.

The LOC properties use the following form.

```
LOC=A42
```

```
LOC=P37
```

Output Slew Rate Property

As mentioned above, a variety of symbol names provide the option of choosing the desired slew rate for the output buffers. In the case of the LVTTTL output buffers (OBUF, OBUFT, and IOBUF), slew rate control can be alternatively programmed with the SLEW= property. By default, the slew rate for each output buffer is reduced to minimize power bus transients when switching non-critical signals. The SLEW= property has one of the two following values.

```
SLEW=SLOW
```

```
SLEW=FAST
```

Output Drive Strength Property

The desired output drive strength can be additionally specified by choosing the appropriate library symbol. The Xilinx library also provides an alternative method for specifying this feature. For the LVTTTL output buffers (OBUF, OBUFT, and IOBUF), the desired drive strength can be specified with the DRIVE= property. This property could have one of the following seven values.

```
DRIVE=2
```

```
DRIVE=4
```

```
DRIVE=6
```

```
DRIVE=8
```

```
DRIVE=12 (Default)
```

```
DRIVE=16
```

```
DRIVE=24
```

Design Considerations

Reference Voltage (V_{REF}) Pins

Low-voltage I/O standards with a differential amplifier input buffer require an input reference voltage (V_{REF}). Provide the V_{REF} as an external signal to the device.

The voltage reference signal is “banked” within the device on a half-edge basis such that for all packages there are eight independent V_{REF} banks internally. See [Figure 38](#) for a representation of the Virtex-E I/O banks. Within each bank approximately one of every six I/O pins is automatically configured as a V_{REF} input. After placing a differential amplifier input signal within a given V_{REF} bank, the same external source must drive all I/O pins configured as a V_{REF} input.

Within each V_{REF} bank, any input buffers that require a V_{REF} signal must be of the same type. Output buffers of any type and input buffers can be placed without requiring a reference voltage within the same V_{REF} bank.

Output Drive Source Voltage (V_{CCO}) Pins

Many of the low voltage I/O standards supported by SelectI/O devices require a different output drive source voltage (V_{CCO}). As a result each device can often have to support multiple output drive source voltages.

The Virtex-E series supports eight banks for the HQ and PQ packages. The CS package supports four V_{CCO} banks.

Output buffers within a given V_{CCO} bank must share the same output drive source voltage. Input buffers for LVTTTL, LVCMOS2, LVCMOS18, PCI33_3, and PCI 66_3 use the V_{CCO} voltage for Input V_{CCO} voltage.

Transmission Line Effects

The delay of an electrical signal along a wire is dominated by the rise and fall times when the signal travels a short distance. Transmission line delays vary with inductance and capacitance, but a well-designed board can experience delays of approximately 180 ps per inch.

Transmission line effects, or reflections, typically start at 1.5" for fast (1.5 ns) rise and fall times. Poor (or non-existent) termination or changes in the transmission line impedance cause these reflections and can cause additional delay in longer traces. As system speeds continue to increase, the effect of I/O delays can become a limiting factor and therefore transmission line termination becomes increasingly more important.

Termination Techniques

A variety of termination techniques reduce the impact of transmission line effects.

The following are output termination techniques:

- None
- Series
- Parallel (Shunt)
- Series and Parallel (Series-Shunt)

Input termination techniques include the following:

- None
- Parallel (Shunt)

These termination techniques can be applied in any combination. A generic example of each combination of termination methods appears in **Figure 43**.

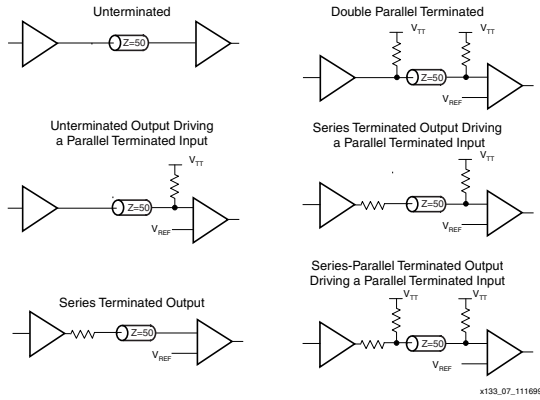

Figure 43: Overview of Standard Input and Output Termination Methods

Simultaneous Switching Guidelines

Ground bounce can occur with high-speed digital ICs when multiple outputs change states simultaneously, causing undesired transient behavior on an output, or in the internal logic. This problem is also referred to as the Simultaneous Switching Output (SSO) problem.

Ground bounce is primarily due to current changes in the combined inductance of ground pins, bond wires, and ground metallization. The IC internal ground level deviates from the external system ground level for a short duration (a few nanoseconds) after multiple outputs change state simultaneously.

Ground bounce affects stable Low outputs and all inputs because they interpret the incoming signal by comparing it to the internal ground. If the ground bounce amplitude exceeds the actual instantaneous noise margin, then a non-changing input can be interpreted as a short pulse with a polarity opposite to the ground bounce.

Table 21 provides the guidelines for the maximum number of simultaneously switching outputs allowed per output power/ground pair to avoid the effects of ground bounce. Refer to **Table 22** for the number of effective output power/ground pairs for each Virtex-E device and package combination.

Table 21: Guidelines for Maximum Number of Simultaneously Switching Outputs per Power/Ground Pair

Standard	Package
	BGA, FGA
LVTTTL Slow Slew Rate, 2 mA drive	68
LVTTTL Slow Slew Rate, 4 mA drive	41
LVTTTL Slow Slew Rate, 6 mA drive	29
LVTTTL Slow Slew Rate, 8 mA drive	22
LVTTTL Slow Slew Rate, 12 mA drive	17
LVTTTL Slow Slew Rate, 16 mA drive	14
LVTTTL Slow Slew Rate, 24 mA drive	9
LVTTTL Fast Slew Rate, 2 mA drive	40
LVTTTL Fast Slew Rate, 4 mA drive	24
LVTTTL Fast Slew Rate, 6 mA drive	17
LVTTTL Fast Slew Rate, 8 mA drive	13
LVTTTL Fast Slew Rate, 12 mA drive	10
LVTTTL Fast Slew Rate, 16 mA drive	8
LVTTTL Fast Slew Rate, 24 mA drive	5
LVC MOS	10
PCI	8
GTL	4
GTL+	4
HSTL Class I	18
HSTL Class III	9
HSTL Class IV	5
SSTL2 Class I	15
SSTL2 Class II	10
SSTL3 Class I	11
SSTL3 Class II	7
CTT	14
AGP	9

Note: This analysis assumes a 35 pF load for each output.

Table 22: Virtex-E Extended Memory Family Equivalent Power/Ground Pairs

Pkg/Part	XCV405E	XCV812E
BG560		56
FG676	56	
FG900		

Application Examples

Creating a design with the SelectI/O features requires the instantiation of the desired library symbol within the design code. At the board level, designers need to know the termination techniques required for each I/O standard.

This section describes some common application examples illustrating the termination techniques recommended by each of the standards supported by the SelectI/O features.

Termination Examples

Circuit examples involving typical termination techniques for each of the SelectI/O standards follow. For a full range of accepted values for the DC voltage specifications for each standard, refer to the table associated with each figure.

The resistors used in each termination technique example and the transmission lines depicted represent board level components and are not meant to represent components on the device.

GTL

A sample circuit illustrating a valid termination technique for GTL is shown in Figure 44. Table 23 lists DC voltage specifications.

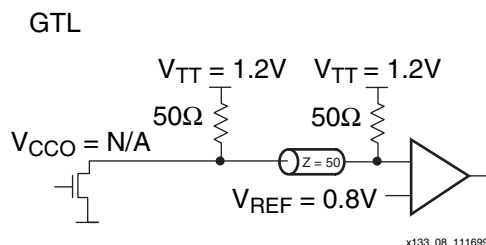

Figure 44: Terminated GTL

Table 23: GTL Voltage Specifications

Parameter	Min	Typ	Max
V_{CCO}	-	N/A	-
$V_{REF} = N \times V_{TT}^1$	0.74	0.8	0.86
V_{TT}	1.14	1.2	1.26
$V_{IH} = V_{REF} + 0.05$	0.79	0.85	-
$V_{IL} = V_{REF} - 0.05$	-	0.75	0.81
V_{OH}	-	-	-
V_{OL}	-	0.2	0.4
I_{OH} at V_{OH} (mA)	-	-	-
I_{OL} at V_{OL} (mA) at 0.4V	32	-	-
I_{OL} at V_{OL} (mA) at 0.2V	-	-	40

Note: N must be greater than or equal to 0.653 and less than or equal to 0.68.

GTL+

A sample circuit illustrating a valid termination technique for GTL+ appears in Figure 45. DC voltage specifications appear in Table 24.

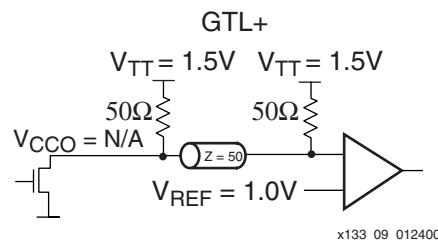

Figure 45: Terminated GTL+

Table 24: GTL+ Voltage Specifications

Parameter	Min	Typ	Max
V_{CCO}	-	-	-
$V_{REF} = N \times V_{TT}^1$	0.88	1.0	1.12
V_{TT}	1.35	1.5	1.65
$V_{IH} = V_{REF} + 0.1$	0.98	1.1	-
$V_{IL} = V_{REF} - 0.1$	-	0.9	1.02
V_{OH}	-	-	-
V_{OL}	0.3	0.45	0.6
I_{OH} at V_{OH} (mA)	-	-	-
I_{OL} at V_{OL} (mA) at 0.6V	36	-	-
I_{OL} at V_{OL} (mA) at 0.3V	-	-	48

Note: N must be greater than or equal to 0.653 and less than or equal to 0.68.

HSTL

A sample circuit illustrating a valid termination technique for HSTL_I appears in Figure 46. A sample circuit illustrating a valid termination technique for HSTL_III appears in Figure 47.

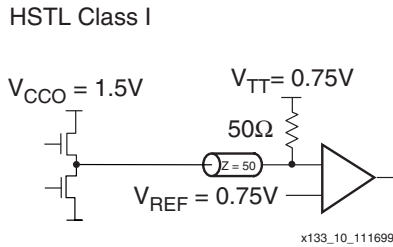

Figure 46: Terminated HSTL Class I

Table 25: HSTL Class I Voltage Specification

Parameter	Min	Typ	Max
V _{CCO}	1.40	1.50	1.60
V _{REF}	0.68	0.75	0.90
V _{TT}	-	V _{CCO} × 0.5	-
V _{IH}	V _{REF} + 0.1	-	-
V _{IL}	-	-	V _{REF} - 0.1
V _{OH}	V _{CCO} - 0.4	-	-
V _{OL}			0.4
I _{OH} at V _{OH} (mA)	-8	-	-
I _{OL} at V _{OL} (mA)	8	-	-

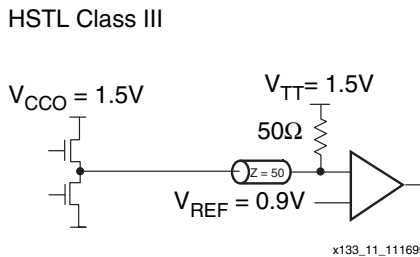

Figure 47: Terminated HSTL Class III

Table 26: HSTL Class III Voltage Specification

Parameter	Min	Typ	Max
V _{CCO}	1.40	1.50	1.60
V _{REF} ⁽¹⁾	-	0.90	-
V _{TT}	-	V _{CCO}	-
V _{IH}	V _{REF} + 0.1	-	-
V _{IL}	-	-	V _{REF} - 0.1
V _{OH}	V _{CCO} - 0.4	-	-
V _{OL}	-	-	0.4
I _{OH} at V _{OH} (mA)	-8	-	-
I _{OL} at V _{OL} (mA)	24	-	-

Note: Per EIA/JESD8-6, "The value of V_{REF} is to be selected by the user to provide optimum noise margin in the use conditions specified by the user."

A sample circuit illustrating a valid termination technique for HSTL_IV appears in Figure 48.

HSTL Class IV

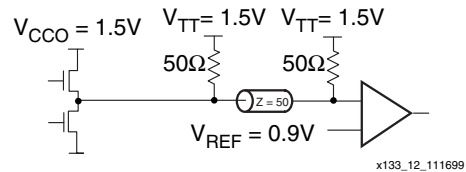

Figure 48: Terminated HSTL Class IV

Table 27: HSTL Class IV Voltage Specification

Parameter	Min	Typ	Max
V _{CCO}	1.40	1.50	1.60
V _{REF}	-	0.90	-
V _{TT}	-	V _{CCO}	-
V _{IH}	V _{REF} + 0.1	-	-
V _{IL}	-	-	V _{REF} - 0.1
V _{OH}	V _{CCO} - 0.4	-	-
V _{OL}	-	-	0.4
I _{OH} at V _{OH} (mA)	-8	-	-
I _{OL} at V _{OL} (mA)	48	-	-

Note: Per EIA/JESD8-6, "The value of V_{REF} is to be selected by the user to provide optimum noise margin in the use conditions specified by the user."

SSTL3_I

A sample circuit illustrating a valid termination technique for SSTL3_I appears in Figure 49. DC voltage specifications appear in Table 28.

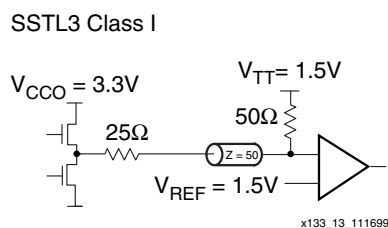

Figure 49: Terminated SSTL3 Class I

Table 28: SSTL3_I Voltage Specifications

Parameter	Min	Typ	Max
V_{CCO}	3.0	3.3	3.6
$V_{REF} = 0.45 \times V_{CCO}$	1.3	1.5	1.7
$V_{TT} = V_{REF}$	1.3	1.5	1.7
$V_{IH} = V_{REF} + 0.2$	1.5	1.7	3.9 ⁽¹⁾
$V_{IL} = V_{REF} - 0.2$	-0.3 ⁽²⁾	1.3	1.5
$V_{OH} = V_{REF} + 0.6$	1.9	-	-
$V_{OL} = V_{REF} - 0.6$	-	-	1.1
I_{OH} at V_{OH} (mA)	-8	-	-
I_{OL} at V_{OL} (mA)	8	-	-

Notes:

- V_{IH} maximum is $V_{CCO} + 0.3$
- V_{IL} minimum does not conform to the formula

SSTL3_II

A sample circuit illustrating a valid termination technique for SSTL3_II appears in Figure 50. DC voltage specifications appear in Table 29.

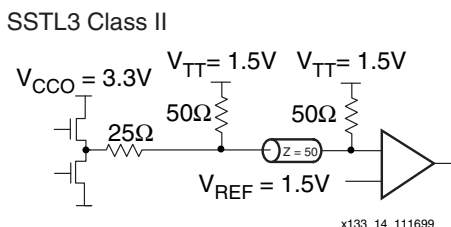

Figure 50: Terminated SSTL3 Class II

Table 29: SSTL3_II Voltage Specifications

Parameter	Min	Typ	Max
V_{CCO}	3.0	3.3	3.6
$V_{REF} = 0.45 \times V_{CCO}$	1.3	1.5	1.7
$V_{TT} = V_{REF}$	1.3	1.5	1.7
$V_{IH} = V_{REF} + 0.2$	1.5	1.7	3.9 ⁽¹⁾
$V_{IL} = V_{REF} - 0.2$	-0.3 ⁽²⁾	1.3	1.5
$V_{OH} = V_{REF} + 0.8$	2.1	-	-
$V_{OL} = V_{REF} - 0.8$	-	-	0.9
I_{OH} at V_{OH} (mA)	-16	-	-
I_{OL} at V_{OL} (mA)	16	-	-

Notes:

- V_{IH} maximum is $V_{CCO} + 0.3$
- V_{IL} minimum does not conform to the formula

SSTL2_I

A sample circuit illustrating a valid termination technique for SSTL2_I appears in Figure 51. DC voltage specifications appear in Table 30.

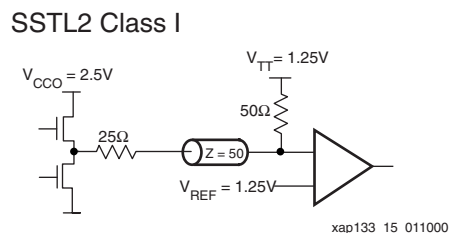

Figure 51: Terminated SSTL2 Class I

Table 30: SSTL2_I Voltage Specifications

Parameter	Min	Typ	Max
V_{CCO}	2.3	2.5	2.7
$V_{REF} = 0.5 \times V_{CCO}$	1.15	1.25	1.35
$V_{TT} = V_{REF} + N(1)$	1.11	1.25	1.39
$V_{IH} = V_{REF} + 0.18$	1.33	1.43	3.0 ⁽²⁾
$V_{IL} = V_{REF} - 0.18$	-0.3 ⁽³⁾	1.07	1.17
$V_{OH} = V_{REF} + 0.61$	1.76	-	-
$V_{OL} = V_{REF} - 0.61$	-	-	0.74
I_{OH} at V_{OH} (mA)	-7.6	-	-
I_{OL} at V_{OL} (mA)	7.6	-	-

Notes:

- N must be greater than or equal to -0.04 and less than or equal to 0.04.
- V_{IH} maximum is $V_{CCO} + 0.3$.
- V_{IL} minimum does not conform to the formula.

SSTL2_II

A sample circuit illustrating a valid termination technique for SSTL2_II appears in **Figure 52**. DC voltage specifications appear in **Table 31**.

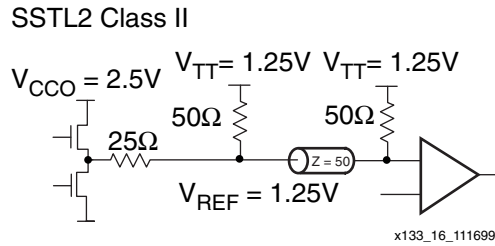

Figure 52: Terminated SSTL2 Class II

Table 31: SSTL2_II Voltage Specifications

Parameter	Min	Typ	Max
V_{CCO}	2.3	2.5	2.7
$V_{REF} = 0.5 \times V_{CCO}$	1.15	1.25	1.35
$V_{TT} = V_{REF} + N^{(1)}$	1.11	1.25	1.39
$V_{IH} = V_{REF} + 0.18$	1.33	1.43	3.0 ⁽²⁾
$V_{IL} = V_{REF} - 0.18$	-0.3 ⁽³⁾	1.07	1.17
$V_{OH} = V_{REF} + 0.8$	1.95	-	-
$V_{OL} = V_{REF} - 0.8$	-	-	0.55
I_{OH} at V_{OH} (mA)	-15.2	-	-
I_{OL} at V_{OL} (mA)	15.2	-	-

Notes:

- N must be greater than or equal to -0.04 and less than or equal to 0.04.
- V_{IH} maximum is $V_{CCO} + 0.3$.
- V_{IL} minimum does not conform to the formula.

CTT

A sample circuit illustrating a valid termination technique for CTT appear in **Figure 53**. DC voltage specifications appear in **Table 32**.

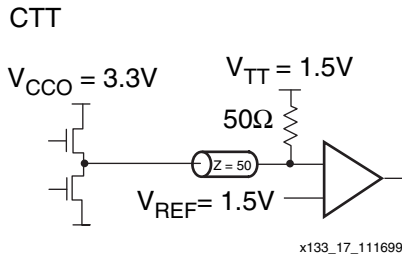

Figure 53: Terminated CTT

Table 32: CTT Voltage Specifications

Parameter	Min	Typ	Max
V_{CCO}	2.05 ⁽¹⁾	3.3	3.6
V_{REF}	1.35	1.5	1.65
V_{TT}	1.35	1.5	1.65
$V_{IH} = V_{REF} + 0.2$	1.55	1.7	-
$V_{IL} = V_{REF} - 0.2$	-	1.3	1.45
$V_{OH} = V_{REF} + 0.4$	1.75	1.9	-
$V_{OL} = V_{REF} - 0.4$	-	1.1	1.25
I_{OH} at V_{OH} (mA)	-8	-	-
I_{OL} at V_{OL} (mA)	8	-	-

Notes:

- Timing delays are calculated based on V_{CCO} min of 3.0V.

PCI33_3 & PCI66_3

PCI33_3 or PCI66_3 require no termination. DC voltage specifications appear in **Table 33**.

Table 33: PCI33_3 and PCI66_3 Voltage Specifications

Parameter	Min	Typ	Max
V_{CCO}	3.0	3.3	3.6
V_{REF}	-	-	-
V_{TT}	-	-	-
$V_{IH} = 0.5 \times V_{CCO}$	1.5	1.65	$V_{CCO} + 0.5$
$V_{IL} = 0.3 \times V_{CCO}$	-0.5	0.99	1.08
$V_{OH} = 0.9 \times V_{CCO}$	2.7	-	-
$V_{OL} = 0.1 \times V_{CCO}$	-	-	0.36
I_{OH} at V_{OH} (mA)	Note 1	-	-
I_{OL} at V_{OL} (mA)	Note 1	-	-

Note 1: Tested according to the relevant specification.

LVTTTL

LVTTTL requires no termination. DC voltage specifications appears in [Table 34](#).

Table 34: LVTTTL Voltage Specifications

Parameter	Min	Typ	Max
V _{CCO}	3.0	3.3	3.6
V _{REF}	-	-	-
V _{TT}	-	-	-
V _{IH}	2.0	-	3.6
V _{IL}	-0.5	-	0.8
V _{OH}	2.4	-	-
V _{OL}	-	-	0.4
I _{OH} at V _{OH} (mA)	-24	-	-
I _{OL} at V _{OL} (mA)	24	-	-

Note: V_{OL} and V_{OH} for lower drive currents sample tested.

LVC MOS2

LVC MOS2 requires no termination. DC voltage specifications appear in [Table 35](#).

Table 35: LVC MOS2 Voltage Specifications

Parameter	Min	Typ	Max
V _{CCO}	2.3	2.5	2.7
V _{REF}	-	-	-
V _{TT}	-	-	-
V _{IH}	1.7	-	3.6
V _{IL}	-0.5	-	0.7
V _{OH}	1.9	-	-
V _{OL}	-	-	0.4
I _{OH} at V _{OH} (mA)	-12	-	-
I _{OL} at V _{OL} (mA)	12	-	-

LVC MOS18

LVC MOS18 does not require termination. [Table 36](#) lists DC voltage specifications.

Table 36: LVC MOS18 Voltage Specifications

Parameter	Min	Typ	Max
V _{CCO}	1.70	1.80	1.90
V _{REF}	-	-	-
V _{TT}	-	-	-
V _{IH}	0.65 x V _{CCO}	-	1.95
V _{IL}	-0.5	-	0.2 x V _{CCO}
V _{OH}	V _{CCO} - 0.4	-	-
V _{OL}	-	-	0.4
I _{OH} at V _{OH} (mA)	-8	-	-
I _{OL} at V _{OL} (mA)	8	-	-

AGP-2X

The specification for the AGP-2X standard does not document a recommended termination technique. DC voltage specifications appear in [Table 37](#).

Table 37: AGP-2X Voltage Specifications

Parameter	Min	Typ	Max
V _{CCO}	3.0	3.3	3.6
V _{REF} = N x V _{CCO} ⁽¹⁾	1.17	1.32	1.48
V _{TT}	-	-	-
V _{IH} = V _{REF} + 0.2	1.37	1.52	-
V _{IL} = V _{REF} - 0.2	-	1.12	1.28
V _{OH} = 0.9 x V _{CCO}	2.7	3.0	-
V _{OL} = 0.1 x V _{CCO}	-	0.33	0.36
I _{OH} at V _{OH} (mA)	Note 2	-	-
I _{OL} at V _{OL} (mA)	Note 2	-	-

Notes:

1. N must be greater than or equal to 0.39 and less than or equal to 0.41.
2. Tested according to the relevant specification.

LVDS

Depending on whether the device is transmitting an LVDS signal or receiving an LVDS signal, there are two different circuits used for LVDS termination. A sample circuit illustrating a valid termination technique for transmitting LVDS signals appears in [Figure 54](#). A sample circuit illustrating a valid termination for receiving LVDS signals appears in [Figure 55](#). [Table 38](#) lists DC voltage specifications. Further information on the specific termination resistor packs shown can be found on [Table 40](#).

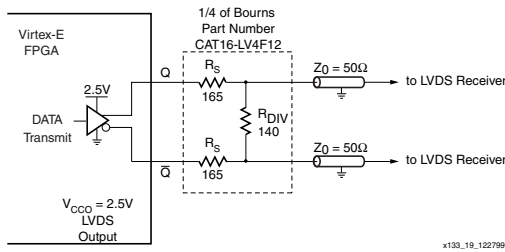

Figure 54: Transmitting LVDS Signal Circuit

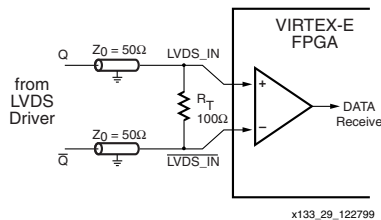

Figure 55: Receiving LVDS Signal Circuit

Table 38: LVDS Voltage Specifications

Parameter	Min	Typ	Max
V _{CCO}	2.375	2.5	2.625
V _{ICM} ⁽²⁾	0.2	1.25	2.2
V _{OCM} ⁽¹⁾	1.125	1.25	1.375
V _{IDIFF} ⁽¹⁾	0.1	0.35	-
V _{ODIFF} ⁽¹⁾	0.25	0.35	0.45
V _{OH} ⁽¹⁾	1.25	-	-
V _{OL} ⁽¹⁾	-	-	1.25

Notes:

1. Measured with a 100 Ω resistor across Q and Q̄.
2. Measured with a differential input voltage = +/- 350 mV.

LVPECL

Depending on whether the device is transmitting or receiving an LVPECL signal, two different circuits are used for LVPECL termination. A sample circuit illustrating a valid termination technique for transmitting LVPECL signals appears in [Figure 56](#). A sample circuit illustrating a valid termination for receiving LVPECL signals appears in [Figure 57](#). [Table 39](#) lists DC voltage specifications. Further information on the specific termination resistor packs shown can be found on [Table 40](#).

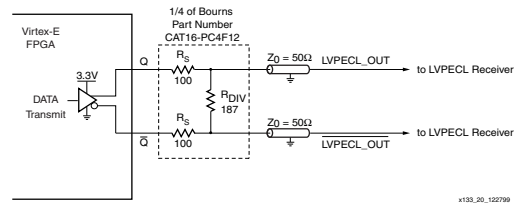

Figure 56: Transmitting LVPECL Signal Circuit

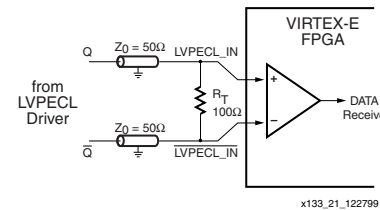

Figure 57: Receiving LVPECL Signal Circuit

Table 39: LVPECL Voltage Specifications

Parameter	Min	Typ	Max
V _{CCO}	3.0	3.3	3.6
V _{REF}	-	-	-
V _{TT}	-	-	-
V _{IH}	1.49	-	2.72
V _{IL}	0.86	-	2.125
V _{OH}	1.8	-	-
V _{OL}	-	-	1.57

Note: For more detailed information, see [LVPECL DC Specifications](#)

Termination Resistor Packs

Resistor packs are available with the values and the configuration required for LVDS and LVPECL termination from Bourns, Inc., as listed in Table. For pricing and availability, please contact Bourns directly at www.bourns.com.

Table 40: Bourns LVDS/LVPECL Resistor Packs

Part Number	I/O Standard	Term. for:	Pairs/Pack	Pins
CAT16-LV2F6	LVDS	Driver	2	8
CAT16-LV4F12	LVDS	Driver	4	16
CAT16-PC2F6	LVPECL	Driver	2	8
CAT16-PC4F12	LVPECL	Driver	4	16
CAT16-PT2F2	LVDS/LVPECL	Receiver	2	8
CAT16-PT4F4	LVDS/LVPECL	Receiver	4	16

LVDS Design Guide

The SelectI/O library elements have been expanded for Virtex-E devices to include new LVDS variants. At this time all of the cells might not be included in the Synthesis libraries. The 2.1i-Service Pack 2 update for Alliance and Foundation software includes these cells in the VHDL and Verilog libraries. It is necessary to combine these cells to create the P-side (positive) and N-side (negative) as described in the input, output, 3-state and bidirectional sections.

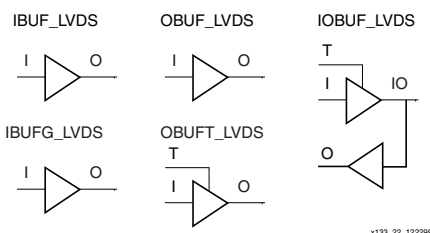

Figure 58: LVDS Elements

Creating LVDS Global Clock Input Buffers

The global clock input buffer can be combined with the adjacent IOB to form an LVDS clock input buffer. The P-side resides in the GCLKPAD location and the N-side resides in the adjacent IO_LVDS_DLL site.

Table 41: Global Clock Input Buffer Pair Locations

Pkg	Pair 3		Pair 2		Pair 2		Pair 0	
	P	N	P	N	P	N	P	N
BG560	A17	C18	D17	E17	AJ17	AM18	AL17	AM17
FG676	E13	B13	C13	F14	AB13	AF13	AA14	AC14
FG900	C15	A15	E15	E16	AK16	AH16	AJ16	AF16

HDL Instantiation

Only one global clock input buffer is required to be instantiated in the design and placed on the correct GCLKPAD location. The N-side of the buffer is reserved and no other IOB is allowed to be placed on this location.

In the physical device, a configuration option is enabled that routes the pad wire to the differential input buffer located in the GCLKIOB. The output of this buffer then drives the output of the GCLKIOB cell. In EPIC it appears that the second buffer is unused. Any attempt to use this location for another purpose leads to a DRC error in the software.

VHDL Instantiation

```
gclk0_p : IBUFG_LVDS port map
(I=>clk_external, O=>clk_internal);
```

Verilog Instantiation

```
IBUFG_LVDS gclk0_p (.I(clk_external),
.O(clk_internal));
```

Location Constraints

All LVDS buffers must be explicitly placed on a device. For the global clock input buffers this can be done with the following constraint in the UCF or NCF file.

```
NET clk_external LOC = GCLKPAD3;
```

GCLKPAD3 can also be replaced with the package pin name, such as D17 for the BG432 package.

Optional N-Side

Some designers might prefer to also instantiate the N-side buffer for the global clock buffer. This allows the top-level net list to include net connections for both PCB layout and system-level integration. In this case, only the output P-side IBUFG connection has a net connected to it. Since the N-side IBUFG does not have a connection in the EDIF net list, it is trimmed from the design in MAP.

VHDL Instantiation

```
gclk0_p : IBUFG_LVDS port map
(I=>clk_p_external, O=>clk_internal);
gclk0_n : IBUFG_LVDS port map
(I=>clk_n_external, O=>clk_internal);
```

Verilog Instantiation

```
IBUFG_LVDS gclk0_p (.I(clk_p_external),
.O(clk_internal));
IBUFG_LVDS gclk0_n (.I(clk_n_external),
.O(clk_internal));
```

Location Constraints

All LVDS buffers must be explicitly placed on a device. For the global clock input buffers this can be done with the following constraint in the UCF or NCF file.

```
NET clk_p_external LOC = GCLKPAD3;
NET clk_n_external LOC = C17;
```

GCLKPAD3 can also be replaced with the package pin name, such as D17 for the BG432 package.

Creating LVDS Input Buffers

An LVDS input buffer can be placed in a wide number of IOB locations. The exact location is dependent on the package that is used. The Virtex-E package information lists the possible locations as IO_L#P for the P-side and IO_L#N for the N-side where # is the pair number.

HDL Instantiation

Only one input buffer is required to be instantiated in the design and placed on the correct IO_L#P location. The N-side of the buffer is reserved and no other IOB is allowed to be placed on this location. In the physical device, a configuration option is enabled that routes the pad wire from the IO_L#N IOB to the differential input buffer located in the IO_L#P IOB. The output of this buffer then drives the output of the IO_L#P cell or the input register in the IO_L#P IOB. In EPIC it appears that the second buffer is unused. Any attempt to use this location for another purpose leads to a DRC error in the software.

VHDL Instantiation

```
data0_p : IBUF_LVDS port map (I=>data(0),
                             O=>data_int(0));
```

Verilog Instantiation

```
IBUF_LVDS data0_p (.I(data[0]),
                  .O(data_int[0]));
```

Location Constraints

All LVDS buffers must be explicitly placed on a device. For the input buffers this can be done with the following constraint in the UCF or NCF file.

```
NET data<0> LOC = D28; # IO_L0P
```

Optional N-side

Some designers might prefer to also instantiate the N-side buffer for the input buffer. This allows the top-level net list to include net connections for both PCB layout and system-level integration. In this case, only the output P-side IBUF connection has a net connected to it. Since the N-side IBUF does not have a connection in the EDIF net list, it is trimmed from the design in MAP.

VHDL Instantiation

```
data0_p : IBUF_LVDS port map
(I=>data_p(0), O=>data_int(0));
data0_n : IBUF_LVDS port map
(I=>data_n(0), O=>open);
```

Verilog Instantiation

```
IBUF_LVDS data0_p (.I(data_p[0]),
                  .O(data_int[0]));
IBUF_LVDS data0_n (.I(data_n[0]), .O());
```

Location Constraints

All LVDS buffers must be explicitly placed on a device. For the global clock input buffers this can be done with the following constraint in the UCF or NCF file.

```
NET data_p<0> LOC = D28; # IO_L0P
NET data_n<0> LOC = B29; # IO_L0N
```

Adding an Input Register

All LVDS buffers can have an input register in the IOB. The input register is in the P-side IOB only. All the normal IOB register options are available (FD, FDE, FDC, FDCE, FDP, FDPE, FDR, FDRE, FDS, FDSE, LD, LDE, LDC, LDCE, LDP, LDPE). The register elements can be inferred or explicitly instantiated in the HDL code.

The register elements can be packed in the IOB using the IOB property to TRUE on the register or by using “map -pr [ilolb]”, where “i” is inputs only, “o” is outputs only, and “b” is both inputs and outputs.

To improve design coding times VHDL and Verilog synthesis macro libraries available to explicitly create these structures. The input library macros are listed in Table 42. The I and IB inputs to the macros are the external net connections.

Table 42: Input Library Macros

Name	Inputs	Outputs
IBUFDS_FD_LVDS	I, IB, C	Q
IBUFDS_FDE_LVDS	I, IB, CE, C	Q
IBUFDS_FDC_LVDS	I, IB, C, CLR	Q
IBUFDS_FDCE_LVDS	I, IB, CE, C, CLR	Q
IBUFDS_FDP_LVDS	I, IB, C, PRE	Q
IBUFDS_FDPE_LVDS	I, IB, CE, C, PRE	Q
IBUFDS_FDR_LVDS	I, IB, C, R	Q
IBUFDS_FDRE_LVDS	I, IB, CE, C, R	Q
IBUFDS_FDS_LVDS	I, IB, C, S	Q
IBUFDS_FDSE_LVDS	I, IB, CE, C, S	Q
IBUFDS_LD_LVDS	I, IB, G	Q
IBUFDS_LDE_LVDS	I, IB, GE, G	Q
IBUFDS_LDC_LVDS	I, IB, G, CLR	Q
IBUFDS_LDCE_LVDS	I, IB, GE, G, CLR	Q
IBUFDS_LDP_LVDS	I, IB, G, PRE	Q
IBUFDS_LDPE_LVDS	I, IB, GE, G, PRE	Q

Creating LVDS Output Buffers

LVDS output buffer can be placed in wide number of IOB locations. The exact location are dependent on the package that is used. The Virtex-E package information lists the possible locations as IO_L#P for the P-side and IO_L#N for the N-side where # is the pair number.

HDL Instantiation

Both output buffers are required to be instantiated in the design and placed on the correct IO_L#P and IO_L#N locations. The IOB must have the same net source the following pins, clock (C), set/reset (SR), output (O), output clock enable (OCE). In addition, the output (O) pins must be inverted with respect to each other, and if output registers are used, the INIT states must be opposite values (one HIGH and one LOW). Failure to follow these rules leads to DRC errors in software.

VHDL Instantiation

```
data0_p : OBUF_LVDS port map
(I=>data_int(0), O=>data_p(0));

data0_inv: INV      port map
(I=>data_int(0), O=>data_n_int(0));

data0_n : OBUF_LVDS port map
(I=>data_n_int(0), O=>data_n(0));
```

Verilog Instantiation

```
OBUF_LVDS data0_p (.I(data_int[0]),
.O(data_p[0]));

INV      data0_inv (.I(data_int[0],
.O(data_n_int[0]));

OBUF_LVDS data0_n (.I(data_n_int[0]),
.O(data_n[0]));
```

Location Constraints

All LVDS buffers must be explicitly placed on a device. For the output buffers this can be done with the following constraint in the UCF or NCF file.

```
NET data_p<0> LOC = D28; # IO_L0P
NET data_n<0> LOC = B29; # IO_L0N
```

Synchronous vs. Asynchronous Outputs

If the outputs are synchronous (registered in the IOB), then any IO_L#PIN pair can be used. If the outputs are asynchronous (no output register), then they must use one of the pairs that are part of the same IOB group at the end of a ROW or at the top/bottom of a COLUMN in the device.

The LVDS pairs that can be used as asynchronous outputs are listed in the Virtex-E pinout tables. Some pairs are marked as asynchronous-capable for all devices in that package, and others are marked as available only for that device in the package. If the device size might change at

some point in the product lifetime, then only the common pairs for all packages should be used.

Adding an Output Register

All LVDS buffers can have an output register in the IOB. The output registers must be in both the P-side and N-side IOBs. All the normal IOB register options are available (FD, FDE, FDC, FDCE, FDP, FDPE, FDR, FDRE, FDS, FDSE, LD, LDE, LDC, LDCE, LDP, LDPE). The register elements can be inferred or explicitly instantiated in the HDL code.

Special care must be taken to insure that the D pins of the registers are inverted and that the INIT states of the registers are opposite. The clock pin (C), clock enable (CE) and set/reset (CLR/PRE or S/R) pins must connect to the same source. Failure to do this leads to a DRC error in the software.

The register elements can be packed in the IOB using the IOB property to TRUE on the register or by using the “map-pr [ilolb]” where “i” is inputs only, “o” is outputs only and “b” is both inputs and outputs.

To improve design coding times VHDL and Verilog synthesis macro libraries have been developed to explicitly create these structures. The output library macros are listed in [Table 43](#). The O and OB inputs to the macros are the external net connections.

Table 43: Output Library Macros

Name	Inputs	Outputs
OBUFDS_FD_LVDS	D, C	O, OB
OBUFDS_FDE_LVDS	DD, CE, C	O, OB
OBUFDS_FDC_LVDS	D, C, CLR	O, OB
OBUFDS_FDCE_LVDS	D, CE, C, CLR	O, OB
OBUFDS_FDP_LVDS	D, C, PRE	O, OB
OBUFDS_FDPE_LVDS	D, CE, C, PRE	O, OB
OBUFDS_FDR_LVDS	D, C, R	O, OB
OBUFDS_FDRE_LVDS	D, CE, C, R	O, OB
OBUFDS_FDS_LVDS	D, C, S	O, OB
OBUFDS_FDSE_LVDS	D, CE, C, S	O, OB
OBUFDS_LD_LVDS	D, G	O, OB
OBUFDS_LDE_LVDS	D, GE, G	O, OB
OBUFDS_LDC_LVDS	D, G, CLR	O, OB
OBUFDS_LDCE_LVDS	D, GE, G, CLR	O, OB
OBUFDS_LDP_LVDS	D, G, PRE	O, OB
OBUFDS_LDPE_LVDS	D, GE, G, PRE	O, OB

Creating LVDS Output 3-State Buffers

LVDS output 3-state buffers can be placed in a wide number of IOB locations. The exact locations are dependent on the package used. The Virtex-E package information lists the possible locations as IO_L#P for the P-side and IO_L#N for the N-side, where # is the pair number.

HDL Instantiation

Both output 3-state buffers are required to be instantiated in the design and placed on the correct IO_L#P and IO_L#N locations. The IOB must have the same net source the following pins, clock (C), set/reset (SR), 3-state (T), 3-state clock enable (TCE), output (O), output clock enable (OCE). In addition, the output (O) pins must be inverted with respect to each other, and if output registers are used, the INIT states must be opposite values (one High and one Low). If 3-state registers are used, they must be initialized to the same state. Failure to follow these rules leads to DRC errors in the software.

VHDL Instantiation

```
data0_p:  OBUFT_LVDS port map
(I=>data_int(0), T=>data_tri,
O=>data_p(0));

data0_inv: INV port map
(I=>data_int(0), O=>data_n_int(0));

data0_n:  OBUFT_LVDS port map
(I=>data_n_int(0), T=>data_tri,
O=>data_n(0));
```

Verilog Instantiation

```
OBUFT_LVDS data0_p (.I(data_int[0]),
.T(data_tri), .O(data_p[0]));

INV          data0_inv (.I(data_int[0],
.O(data_n_int[0]));

OBUFT_LVDS data0_n (.I(data_n_int[0]),
.T(data_tri), .O(data_n[0]));
```

Location Constraints

All LVDS buffers must be explicitly placed on a device. For the output buffers this can be done with the following constraint in the UCF or NCF file.

```
NET data_p<0> LOC = D28; # IO_L0P
NET data_n<0> LOC = B29; # IO_L0N
```

Synchronous vs. Asynchronous 3-State Outputs

If the outputs are synchronous (registered in the IOB), then any IO_L#PIN pair can be used. If the outputs are asynchronous (no output register), then they must use one of the pairs that are part of the same IOB group at the end of a ROW or at the top/bottom of a COLUMN in the device. This applies for either the 3-state pin or the data out pin.

LVDS pairs that can be used as asynchronous outputs are listed in the Virtex-E pinout tables. Some pairs are marked as “asynchronous capable” for all devices in that package, and others are marked as available only for that device in the package. If the device size might be changed at some point in the product lifetime, then only the common pairs for all packages should be used.

Adding Output and 3-State Registers

All LVDS buffers can have an output register in the IOB. The output registers must be in both the P-side and N-side IOBs. All the normal IOB register options are available (FD, FDE, FDC, FDCE, FDP, FDPE, FDR, FDRE, FDS, FDSE, LD, LDE, LDC, LDCE, LDP, LDPE). The register elements can be inferred or explicitly instantiated in the HDL code.

Special care must be taken to insure that the D pins of the registers are inverted and that the INIT states of the registers are opposite. The 3-state (T), 3-state clock enable (CE), clock pin (C), output clock enable (CE) and set/reset (CLR/PRE or S/R) pins must connect to the same source. Failure to do this leads to a DRC error in the software.

The register elements can be packed in the IOB using the IOB property to TRUE on the register or by using the “map-pr [ilolb]” where “i” is inputs only, “o” is outputs only and “b” is both inputs and outputs.

To improve design coding times VHDL and Verilog synthesis macro libraries have been developed to explicitly create these structures. The input library macros are listed below. The 3-state is configured to be 3-stated at GSR and when the PRE,CLR,S or R is asserted and shares it's clock enable with the output register. If this is not desirable, the library can be updated by the user for the desired functionality. The O and OB inputs to the macros are the external net connections.

Creating LVDS Bidirectional Buffer

LVDS bidirectional buffers can be placed in a wide number of IOB locations. The exact locations are dependent on the package used. The Virtex-E package information lists the possible locations as IO_L#P for the P-side and IO_L#N for the N-side, where # is the pair number.

HDL Instantiation

Both bidirectional buffers are required to be instantiated in the design and placed on the correct IO_L#P and IO_L#N locations. The IOB must have the same net source the following pins, clock (C), set/reset (SR), 3-state (T), 3-state clock enable (TCE), output (O), output clock enable (OCE). In addition, the output (O) pins must be inverted with respect to each other, and if output registers are used, the INIT states must be opposite values (one HIGH and one LOW). If 3-state registers are used, they must be initialized to the same state. Failure to follow these rules leads to DRC errors in the software.

VHDL Instantiation

```
data0_p: IOBUF_LVDS port map
(I=>data_out(0), T=>data_tri,
IO=>data_p(0), O=>data_int(0));

data0_inv: INV port map
(I=>data_out(0), O=>data_n_out(0));

data0_n : IOBUF_LVDS port map
(I=>data_n_out(0), T=>data_tri,
IO=>data_n(0), O=>open);
```

Verilog Instantiation

```
IOBUF_LVDS data0_p(.I(data_out[0]),
.T(data_tri), .IO(data_p[0]),
.O(data_int[0]));

INV data0_inv (.I(data_out[0],
.O(data_n_out[0]));

IOBUF_LVDS
data0_n(.I(data_n_out[0]),.T(data_tri),.
IO(data_n[0]).O());
```

Location Constraints

All LVDS buffers must be explicitly placed on a device. For the output buffers this can be done with the following constraint in the UCF or NCF file.

```
NET data_p<0> LOC = D28; # IO_L0P
NET data_n<0> LOC = B29; # IO_L0N
```

Synchronous vs. Asynchronous Bidirectional Buffers

If the output side of the bidirectional buffers are synchronous (registered in the IOB), then any IO_L#PIN pair can be used. If the output side of the bidirectional buffers are asynchronous (no output register), then they must use one of the pairs that is a part of the asynchronous LVDS IOB group. This applies for either the 3-state pin or the data out pin.

Table 44: Bidirectional I/O Library Macros

Name	Inputs	Bidirectional	Outputs
IOBUFDS_FD_LVDS	D, T, C	IO, IOB	Q
IOBUFDS_FDE_LVDS	D, T, CE, C	IO, IOB	Q
IOBUFDS_FDC_LVDS	D, T, C, CLR	IO, IOB	Q
IOBUFDS_FDCE_LVDS	D, T, CE, C, CLR	IO, IOB	Q
IOBUFDS_FDP_LVDS	D, T, C, PRE	IO, IOB	Q
IOBUFDS_FDPE_LVDS	D, T, CE, C, PRE	IO, IOB	Q
IOBUFDS_FDR_LVDS	D, T, C, R	IO, IOB	Q
IOBUFDS_FDRE_LVDS	D, T, CE, C, R	IO, IOB	Q
IOBUFDS_FDS_LVDS	D, T, C, S	IO, IOB	Q
IOBUFDS_FDSE_LVDS	D, T, CE, C, S	IO, IOB	Q

The LVDS pairs that can be used as asynchronous bidirectional buffers are listed in the Virtex-E pinout tables. Some pairs are marked as asynchronous capable for all devices in that package, and others are marked as available only for that device in the package. If the device size might change at some point in the product's lifetime, then only the common pairs for all packages should be used.

Adding Output and 3-State Registers

All LVDS buffers can have output and input registers in the IOB. The output registers must be in both the P-side and N-side IOBs, the input register is only in the P-side. All the normal IOB register options are available (FD, FDE, FDC, FDCE, FDP, FDPE, FDR, FDRE, FDS, FDSE, LD, LDE, LDC, LDCE, LDP, LDPE). The register elements can be inferred or explicitly instantiated in the HDL code. Special care must be taken to insure that the D pins of the registers are inverted and that the INIT states of the registers are opposite. The 3-state (T), 3-state clock enable (CE), clock pin (C), output clock enable (CE), and set/reset (CLR/PRE or S/R) pins must connect to the same source. Failure to do this leads to a DRC error in the software.

The register elements can be packed in the IOB using the IOB property to TRUE on the register or by using the "map-pr [iolob]", where "i" is inputs only, "o" is outputs only, and "b" is both inputs and outputs. To improve design coding times, VHDL and Verilog synthesis macro libraries have been developed to explicitly create these structures. The bidirectional I/O library macros are listed in Table 44.

The 3-state is configured to be 3-stated at GSR and when the PRE, CLR, S, or R is asserted and shares its clock enable with the output and input register. If this is not desirable, then the library can be updated with the desired functionality by the user. The I/O and IOB inputs to the macros are the external net connections.

Table 44: Bidirectional I/O Library Macros (Continued)

Name	Inputs	Bidirectional	Outputs
IOBUFDS_LD_LVDS	D, T, G	IO, IOB	Q
IOBUFDS_LDE_LVDS	D, T, GE, G	IO, IOB	Q
IOBUFDS_LDC_LVDS	D, T, G, CLR	IO, IOB	Q
IOBUFDS_LDCE_LVDS	D, T, GE, G, CLR	IO, IOB	Q
IOBUFDS_LDP_LVDS	D, T, G, PRE	IO, IOB	Q
IOBUFDS_LDPE_LVDS	D, T, GE, G, PRE	IO, IOB	Q

Revision History

The following table shows the revision history for this document.

Date	Version	Revision
03/23/2000	1.0	Initial Xilinx release.
08/01/2000	1.1	Accumulated edits and fixes. Upgrade to Preliminary. Preview -8 numbers added. Reformatted to adhere to corporate documentation style guidelines. Minor changes in BG560 pin-out table.
09/19/2000	1.2	<ul style="list-style-type: none"> In Table 3 (Module 4), FG676 Fine-Pitch BGA — XCV405E, the following pins are no longer labeled as VREF: B7, G16, G26, W26, AF20, AF8, Y1, H1. Min values added to Virtex-E Electrical Characteristics tables.
11/20/2000	1.3	<ul style="list-style-type: none"> Updated speed grade -8 numbers in Virtex-E Electrical Characteristics tables (Module 3). Updated minimums in Table 11 (Module 2), and added notes to Table 12 (Module 2). Added to note 2 of Absolute Maximum Ratings (Module 3). Changed all minimum hold times to -0.4 for Global Clock Set-Up and Hold for LVTTTL Standard, with DLL (Module 3). Revised maximum T_{DLLPW} in -6 speed grade for DLL Timing Parameters (Module 3).
04/02/2001	1.4	<ul style="list-style-type: none"> In Table 4, FG676 Fine-Pitch BGA — XCV405E, pin B19 is no longer labeled as VREF, and pin G16 is now labeled as VREF. Updated values in Virtex-E Switching Characteristics tables. Converted data sheet to modularized format.
04/19/2001	1.5	<ul style="list-style-type: none"> Modified Figure 30, which shows “DLL Generation of 4x Clock in Virtex-E Devices.”
07/23/2001	1.6	<ul style="list-style-type: none"> Made minor edits to text under Configuration.
11/16/2001	2.0	<ul style="list-style-type: none"> Added warning under Configuration section that attempting to load an incorrect bitstream causes configuration to fail and can damage the device.
07/17/2002	2.1	<ul style="list-style-type: none"> Data sheet designation upgraded from Preliminary to Production.
09/10/2002	2.2	<ul style="list-style-type: none"> Added clarifications in the Input/Output Block, Configuration, Boundary-Scan Mode, and Block SelectRAM+ Memory sections. Revised Figure 18, Table 11, and Table 36.
11/19/2002	2.3	<ul style="list-style-type: none"> Added clarification in the Boundary Scan section. Removed last sentence regarding deactivation of duty-cycle correction in Duty Cycle Correction Property section.
03/21/2014	3.0	<ul style="list-style-type: none"> This product is obsolete/discontinued per XCN12026.

Virtex-E Extended Memory Data Sheet

The Virtex-E Extended Memory Data Sheet contains the following modules:

- DS025-1, Virtex-E 1.8V Extended Memory FPGAs: Introduction and Ordering Information (Module 1)
- DS025-2, Virtex-E 1.8V Extended Memory FPGAs: Functional Description (Module 2)
- DS025-3, Virtex-E 1.8V Extended Memory FPGAs: DC and Switching Characteristics (Module 3)
- DS025-4, Virtex-E 1.8V Extended Memory FPGAs: Pinout Tables (Module 4)



Virtex™-E 1.8 V Extended Memory Field Programmable Gate Arrays

DS025-3 (v3.0) March 21, 2014

Production Product Specification

Virtex-E Extended Memory Electrical Characteristics

Definition of Terms

Electrical and switching characteristics are specified on a per-speed-grade basis and can be designated as Advance, Preliminary, or Production. Each designation is defined as follows:

Advance: These speed files are based on simulations only and are typically available soon after device design specifications are frozen. Although speed grades with this designation are considered relatively stable and conservative, some under-reporting might still occur.

Preliminary: These speed files are based on complete ES (engineering sample) silicon characterization. Devices and speed grades with this designation are intended to give a better indication of the expected performance of production silicon. The probability of under-reporting delays is greatly reduced as compared to Advance data.

Production: These speed files are released once enough production silicon of a particular device family member has been characterized to provide full correlation between speed files and devices over numerous production lots. There is no under-reporting of delays, and customers receive formal notification of any subsequent changes. Typ-

ically, the slowest speed grades transition to Production before faster speed grades.

All specifications are representative of worst-case supply voltage and junction temperature conditions. The parameters included are common to popular designs and typical applications. Contact the factory for design considerations requiring more detailed information.

Table 1 correlates the current status of each Virtex-E Extended Memory device with a corresponding speed file designation.

Table 1: Virtex-E Extended Memory Device Speed Grade Designations

Device	Speed Grade Designations		
	Advance	Preliminary	Production
XCV405E			-8, -7, -6
XCV812E			-8, -7, -6

All specifications are subject to change without notice.

DC Characteristics

Absolute Maximum Ratings

Symbol	Description ⁽¹⁾		Units
V _{CCINT}	Internal Supply voltage relative to GND	-0.5 to 2.0	V
V _{CCO}	Supply voltage relative to GND	-0.5 to 4.0	V
V _{REF}	Input Reference Voltage	-0.5 to 4.0	V
V _{IN} ⁽³⁾	Input voltage relative to GND	-0.5 to V _{CCO} + 0.5	V
V _{TS}	Voltage applied to 3-state output	-0.5 to 4.0	V
V _{CC}	Longest Supply Voltage Rise Time from 0 V – 1.71 V	50	ms
T _{STG}	Storage temperature (ambient)	-65 to +150	°C
T _J	Junction temperature ⁽²⁾	Plastic packages +125	°C

Notes:

1. Stresses beyond those listed under Absolute Maximum Ratings can cause permanent damage to the device. These are stress ratings only, and functional operation of the device at these or any other conditions beyond those listed under Operating Conditions is not implied. Exposure to Absolute Maximum Ratings conditions for extended periods of time can affect device reliability.
2. For soldering guidelines and thermal considerations, see the device packaging information on www.xilinx.com.
3. Inputs configured as PCI are fully PCI compliant. This statement takes precedence over any specification that would imply that the device is not PCI compliant.

© 2000-2014 Xilinx, Inc. All rights reserved. All Xilinx trademarks, registered trademarks, patents, and disclaimers are as listed at <http://www.xilinx.com/legal.htm>. All other trademarks and registered trademarks are the property of their respective owners. All specifications are subject to change without notice.

Recommended Operating Conditions

Symbol	Description		Min	Max	Units
V _{CCINT}	Internal Supply voltage relative to GND, T _J = 0 °C to +85°C	Commercial	1.8 – 5%	1.8 + 5%	V
	Internal Supply voltage relative to GND, T _J = –40°C to +100°C	Industrial	1.8 – 5%	1.8 + 5%	V
V _{CCO}	Supply voltage relative to GND, T _J = 0 °C to +85°C	Commercial	1.2	3.6	V
	Supply voltage relative to GND, T _J = –40°C to +100°C	Industrial	1.2	3.6	V
T _{IN}	Input signal transition time			250	ns

DC Characteristics Over Recommended Operating Conditions

Symbol	Description ⁽¹⁾	Device	Min	Max	Units
V _{DRINT}	Data Retention V _{CCINT} Voltage (below which configuration data might be lost)	All	1.5		V
V _{DRI0}	Data Retention V _{CCO} Voltage (below which configuration data might be lost)	All	1.2		V
I _{CCINTQ}	Quiescent V _{CCINT} supply current ¹	XCV405E		400	mA
		XCV812E		500	mA
I _{CCOQ}	Quiescent V _{CCO} supply current ¹	XCV405E		2	mA
		XCV812E		2	mA
I _L	Input or output leakage current	All	–10	+10	µA
C _{IN}	Input capacitance (sample tested)	BGA, PQ, HQ, packages		8	pF
I _{RPU}	Pad pull-up (when selected) @ V _{in} = 0 V, V _{CCO} = 3.3 V (sample tested)	All	Note 2	0.25	mA
I _{RPD}	Pad pull-down (when selected) @ V _{in} = 3.6 V (sample tested)		Note 2	0.25	mA

Notes:

1. With no output current loads, no active input pull-up resistors, all I/O pins 3-stated and floating.
2. Internal pull-up and pull-down resistors guarantee valid logic levels at unconnected input pins. These pull-up and pull-down resistors do not guarantee valid logic levels when input pins are connected to other circuits.

Power-On Power Supply Requirements

Xilinx FPGAs require a certain amount of supply current during power-on to insure proper device operation. The actual current consumed depends on the power-on ramp rate of the power supply. This is the time required to reach the nominal power supply voltage of the device¹ from 0 V. The fastest ramp rate is 0 V to nominal voltage in 2 ms and the slowest allowed ramp rate is 0 V to nominal voltage in 50 ms. For more details on power supply requirements, see XAPP158 on www.xilinx.com.

Product (Commercial Grade)	Description ⁽²⁾	Current Requirement ⁽³⁾
XCV50E - XCV600E	Minimum required current supply	500 mA
XCV812E - XCV2000E	Minimum required current supply	1 A
XCV2600E - XCV3200E	Minimum required current supply	1.2 A
Virtex-E Family, Industrial Grade	Minimum required current supply	2 A

Notes:

1. Ramp rate used for this specification is from 0 - 1.8 V DC. Peak current occurs on or near the internal power-on reset threshold and lasts for less than 3 ms.
2. Devices are guaranteed to initialize properly with the minimum current available from the power supply as noted above.
3. Larger currents might result if ramp rates are forced to be faster.

DC Input and Output Levels

Values for V_{IL} and V_{IH} are recommended input voltages. Values for I_{OL} and I_{OH} are guaranteed over the recommended operating conditions at the V_{OL} and V_{OH} test points. Only selected standards are tested. These are chosen to ensure that all standards meet their specifications. The selected standards are tested at minimum V_{CCO} with the respective V_{OL} and V_{OH} voltage levels shown. Other standards are sample tested.

Input/Output Standard	V_{IL}		V_{IH}		V_{OL}	V_{OH}	I_{OL}	I_{OH}
	V, min	V, max	V, min	V, max	V, Max	V, Min	mA	mA
LVTTL ⁽¹⁾	-0.5	0.8	2.0	3.6	0.4	2.4	24	-24
LVC MOS2	-0.5	0.7	1.7	2.7	0.4	1.9	12	-12
LVC MOS18	-0.5	20% V_{CCO}	70% V_{CCO}	1.95	0.4	$V_{CCO} - 0.4$	8	-8
PCI, 3.3 V	-0.5	30% V_{CCO}	50% V_{CCO}	$V_{CCO} + 0.5$	10% V_{CCO}	90% V_{CCO}	Note 2	Note 2
GTL	-0.5	$V_{REF} - 0.05$	$V_{REF} + 0.05$	3.6	0.4	n/a	40	n/a
GTL+	-0.5	$V_{REF} - 0.1$	$V_{REF} + 0.1$	3.6	0.6	n/a	36	n/a
HSTL I ⁽³⁾	-0.5	$V_{REF} - 0.1$	$V_{REF} + 0.1$	3.6	0.4	$V_{CCO} - 0.4$	8	-8
HSTL III	-0.5	$V_{REF} - 0.1$	$V_{REF} + 0.1$	3.6	0.4	$V_{CCO} - 0.4$	24	-8
HSTL IV	-0.5	$V_{REF} - 0.1$	$V_{REF} + 0.1$	3.6	0.4	$V_{CCO} - 0.4$	48	-8
SSTL3 I	-0.5	$V_{REF} - 0.2$	$V_{REF} + 0.2$	3.6	$V_{REF} - 0.6$	$V_{REF} + 0.6$	8	-8
SSTL3 II	-0.5	$V_{REF} - 0.2$	$V_{REF} + 0.2$	3.6	$V_{REF} - 0.8$	$V_{REF} + 0.8$	16	-16
SSTL2 I	-0.5	$V_{REF} - 0.2$	$V_{REF} + 0.2$	3.6	$V_{REF} - 0.61$	$V_{REF} + 0.61$	7.6	-7.6
SSTL2 II	-0.5	$V_{REF} - 0.2$	$V_{REF} + 0.2$	3.6	$V_{REF} - 0.80$	$V_{REF} + 0.80$	15.2	-15.2
CTT	-0.5	$V_{REF} - 0.2$	$V_{REF} + 0.2$	3.6	$V_{REF} - 0.4$	$V_{REF} + 0.4$	8	-8
AGP	-0.5	$V_{REF} - 0.2$	$V_{REF} + 0.2$	3.6	10% V_{CCO}	90% V_{CCO}	Note 2	Note 2

Notes:

1. V_{OL} and V_{OH} for lower drive currents are sample tested.
2. Tested according to the relevant specifications.
3. DC input and output levels for HSTL18 (HSTL I/O standard with V_{CCO} of 1.8 V) are provided in an HSTL white paper on www.xilinx.com.

LVDS DC Specifications

DC Parameter	Symbol	Conditions	Min	Typ	Max	Units
Supply Voltage	V_{CCO}		2.375	2.5	2.625	V
Output High Voltage for Q and \bar{Q}	V_{OH}	$R_T = 100 \Omega$ across Q and \bar{Q} signals	1.25	1.425	1.6	V
Output Low Voltage for Q and \bar{Q}	V_{OL}	$R_T = 100 \Omega$ across Q and \bar{Q} signals	0.9	1.075	1.25	V
Differential Output Voltage (Q – \bar{Q}), Q = High (\bar{Q} – Q), \bar{Q} = High	V_{ODIFF}	$R_T = 100 \Omega$ across Q and \bar{Q} signals	250	350	450	mV
Output Common-Mode Voltage	V_{OCM}	$R_T = 100 \Omega$ across Q and \bar{Q} signals	1.125	1.25	1.375	V
Differential Input Voltage (Q – \bar{Q}), Q = High (\bar{Q} – Q), \bar{Q} = High	V_{IDIFF}	Common-mode input voltage = 1.25 V	100	350	NA	mV
Input Common-Mode Voltage	V_{ICM}	Differential input voltage = ± 350 mV	0.2	1.25	2.2	V

Notes:

1. Refer to the Design Consideration section for termination schematics.

LVPECL DC Specifications

These values are valid at the output of the source termination pack shown under **LVPECL**, with a 100 Ω differential load only. The V_{OH} levels are 200 mV below standard LVPECL levels and are compatible with devices tolerant of lower common-mode ranges. The following table summarizes the DC output specifications of LVPECL.

DC Parameter	Min	Max	Min	Max	Min	Max	Units
V_{CCO}	3.0		3.3		3.6		V
V_{OH}	1.8	2.11	1.92	2.28	2.13	2.41	V
V_{OL}	0.96	1.27	1.06	1.43	1.30	1.57	V
V_{IH}	1.49	2.72	1.49	2.72	1.49	2.72	V
V_{IL}	0.86	2.125	0.86	2.125	0.86	2.125	V
Differential Input Voltage	0.3	-	0.3	-	0.3	-	V

Virtex-E Switching Characteristics

All devices are 100% functionally tested. Internal timing parameters are derived from measuring internal test patterns. Listed below are representative values. For more specific, more precise, and worst-case guaranteed data, use the values reported by the static timing analyzer (TRCE in the Xilinx Development System) and back-annotated to the simulation net list. All timing parameters assume worst-case operating conditions (supply voltage and junction temperature). Values apply to all Virtex-E devices unless otherwise noted.

IOB Input Switching Characteristics

Input delays associated with the pad are specified for LVTTTL levels. For other standards, adjust the delays with the values shown in “IOB Input Switching Characteristics Standard Adjustments” on page 6.

Description ⁽¹⁾	Symbol	Device	Speed Grade ⁽²⁾				Units
			Min	-8	-7	-6	
Propagation Delays							
Pad to I output, no delay	T _{IOPI}	All	0.43	0.8	0.8	0.8	ns, max
Pad to I output, with delay	T _{IOPID}	XCV405E	0.51	1.0	1.0	1.0	ns, max
		XCV812E	0.55	1.1	1.1	1.1	ns, max
Pad to output IQ via transparent latch, no delay	T _{IOPLI}	All	0.75	1.4	1.5	1.6	ns, max
Pad to output IQ via transparent latch, with delay	T _{IOPLID}	XCV405E	1.55	3.5	3.6	3.7	ns, max
		XCV812E	1.55	3.5	3.6	3.7	ns, max
Propagation Delays							
Clock							
Minimum Pulse Width, High	T _{CH}	All	0.56	1.2	1.3	1.4	ns, min
Minimum Pulse Width, Low	T _{CL}		0.56	1.2	1.3	1.4	ns, min
Clock CLK to output IQ	T _{IOCKIQ}		0.18	0.4	0.7	0.7	ns, max
Setup and Hold Times with respect to Clock at IOB Input Register							
Pad, no delay	T _{IOPICK} / T _{IOICKP}	All	0.69 / 0	1.3 / 0	1.4 / 0	1.5 / 0	ns, min
Pad, with delay	T _{IOPICKD} / T _{IOICKPD}	XCV405E	1.49 / 0	3.4 / 0	3.5 / 0	3.5 / 0	ns, min
		XCV812E	1.49 / 0	3.4 / 0	3.5 / 0	3.5 / 0	ns, min
ICE input	T _{IOICECK} / T _{IOICKICE}	All	0.28 / 0.0	0.55 / 0.01	0.7 / 0.01	0.7 / 0.01	ns, min
SR input (IFF, synchronous)	T _{IOSRCKI}	All	0.38	0.8	0.9	1.0	ns, min
Set/Reset Delays							
SR input to IQ (asynchronous)	T _{IOSRIQ}	All	0.54	1.1	1.2	1.4	ns, max
GSR to output IQ	T _{GSRQ}	All	3.88	7.6	8.5	9.7	ns, max

Notes:

1. A Zero “0” Hold Time listing indicates no hold time or a negative hold time. Negative values can not be guaranteed “best-case”, but if a “0” is listed, there is no positive hold time.
2. Input timing i for LVTTTL is measured at 1.4 V. For other I/O standards, see [Table 3](#).

IOB Input Switching Characteristics Standard Adjustments

Description	Symbol	Standard	Speed Grade ⁽¹⁾				Units
			Min	-8	-7	-6	
Data Input Delay Adjustments							
Standard-specific data input delay adjustments	$T_{ILVTTTL}$	LVTTTL	0.0	0.0	0.0	0.0	ns
	$T_{ILVCMOS2}$	LVCMOS2	-0.02	0.0	0.0	0.0	ns
	$T_{ILVCMOS18}$	LVCMOS18	-0.02	+0.20	+0.20	+0.20	ns
	T_{ILVDS}	LVDS	0.00	+0.15	+0.15	+0.15	ns
	$T_{ILVPECL}$	LVPECL	0.00	+0.15	+0.15	+0.15	ns
	T_{IPCI33_3}	PCI, 33 MHz, 3.3 V	-0.05	+0.08	+0.08	+0.08	ns
	T_{IPCI66_3}	PCI, 66 MHz, 3.3 V	-0.05	-0.11	-0.11	-0.11	ns
	T_{IGTL}	GTL	+0.10	+0.14	+0.14	+0.14	ns
	$T_{IGTLPLUS}$	GTL+	+0.06	+0.14	+0.14	+0.14	ns
	T_{IHSTL}	HSTL	+0.02	+0.04	+0.04	+0.04	ns
	T_{ISSTL2}	SSTL2	-0.04	+0.04	+0.04	+0.04	ns
	T_{ISSTL3}	SSTL3	-0.02	+0.04	+0.04	+0.04	ns
	T_{ICTT}	CTT	+0.01	+0.10	+0.10	+0.10	ns
	T_{IAGP}	AGP	-0.03	+0.04	+0.04	+0.04	ns

Notes:

- Input timing t_i for LVTTTL is measured at 1.4 V. For other I/O standards, see [Table 3](#).

I

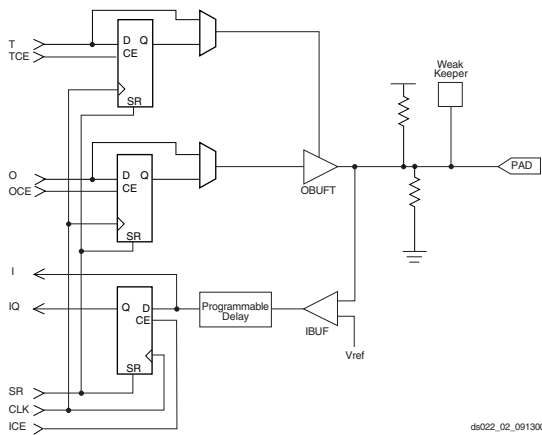

Figure 1: Virtex-E Input/Output Block (IOB)

IOB Output Switching Characteristics, Figure 1

Output delays terminating at a pad are specified for LVTTTL with 12 mA drive and fast slew rate. For other standards, adjust the delays with the values shown in “IOB Output Switching Characteristics Standard Adjustments” on page 8..

Description ⁽¹⁾	Symbol	Speed Grade ⁽²⁾				Units
		Min ³	-8	-7	-6	
Propagation Delays						
O input to Pad	T _{IOOP}	1.04	2.5	2.7	2.9	ns, max
O input to Pad via transparent latch	T _{IOOLP}	1.24	2.9	3.1	3.4	ns, max
3-State Delays						
T input to Pad high-impedance (Note 2)	T _{IOTHZ}	0.73	1.5	1.7	1.9	ns, max
T input to valid data on Pad	T _{IOTON}	1.13	2.7	2.9	3.1	ns, max
T input to Pad high-impedance via transparent latch (Note 2)	T _{IOTLPHZ}	0.86	1.8	2.0	2.2	ns, max
T input to valid data on Pad via transparent latch	T _{IOTLPON}	1.26	3.0	3.2	3.4	ns, max
GTS to Pad high impedance (Note 2)	T _{GTS}	1.94	4.1	4.6	4.9	ns, max
Sequential Delays						
Clock CLK						
Minimum Pulse Width, High	T _{CH}	0.56	1.2	1.3	1.4	ns, min
Minimum Pulse Width, Low	T _{CL}	0.56	1.2	1.3	1.4	ns, min
Clock CLK to Pad	T _{IOCKP}	0.97	2.4	2.8	2.9	ns, max
Clock CLK to Pad high-impedance (synchronous) (Note 2)	T _{IOCKHZ}	0.77	1.6	2.0	2.2	ns, max
Clock CLK to valid data on Pad (synchronous)	T _{IOCKON}	1.17	2.8	3.2	3.4	ns, max
Setup and Hold Times before/after Clock CLK						
O input	T _{IOOCK} / T _{IOCKO}	0.43 / 0	0.9 / 0	1.0 / 0	1.1 / 0	ns, min
OCE input	T _{IOOCECK} / T _{IOCKOCE}	0.28 / 0	0.55 / 0.01	0.7 / 0	0.7 / 0	ns, min
SR input (OFF)	T _{IOSRCKO} / T _{IOCKOSR}	0.40 / 0	0.8 / 0	0.9 / 0	1.0 / 0	ns, min
3-State Setup Times, T input	T _{IOTCK} / T _{IOCKT}	0.26 / 0	0.51 / 0	0.6 / 0	0.7 / 0	ns, min
3-State Setup Times, TCE input	T _{IOTCECK} / T _{IOCKTCE}	0.30 / 0	0.6 / 0	0.7 / 0	0.8 / 0	ns, min
3-State Setup Times, SR input (TFF)	T _{IOSRCKT} / T _{IOCKTSR}	0.38 / 0	0.8 / 0	0.9 / 0	1.0 / 0	ns, min
Set/Reset Delays						
SR input to Pad (asynchronous)	T _{IOSRP}	1.30	3.1	3.3	3.5	ns, max
SR input to Pad high-impedance (asynchronous) (Note 2)	T _{IOSRHZ}	1.08	2.2	2.4	2.7	ns, max
SR input to valid data on Pad (asynchronous)	T _{IOSRON}	1.48	3.4	3.7	3.9	ns, max
GSR to Pad	T _{IOGSRQ}	3.88	7.6	8.5	9.7	ns, max

Notes:

1. A Zero “0” Hold Time listing indicates no hold time or a negative hold time. Negative values can not be guaranteed “best-case”, but if a “0” is listed, there is no positive hold time.
2. 3-state turn-off delays should not be adjusted.

IOB Output Switching Characteristics Standard Adjustments

Output delays terminating at a pad are specified for LVTTTL with 12 mA drive and fast slew rate. For other standards, adjust the delays by the values shown.

Description	Symbol	Standard	Speed Grade				Units
			Min	-8	-7	-6	
Output Delay Adjustments							
Standard-specific adjustments for output delays terminating at pads (based on standard capacitive load, Csl)	T _{OLVTTTL_S2}	LVTTTL, Slow, 2 mA	4.2	+14.7	+14.7	+14.7	ns
	T _{OLVTTTL_S4}	4 mA	2.5	+7.5	+7.5	+7.5	ns
	T _{OLVTTTL_S6}	6 mA	1.8	+4.8	+4.8	+4.8	ns
	T _{OLVTTTL_S8}	8 mA	1.2	+3.0	+3.0	+3.0	ns
	T _{OLVTTTL_S12}	12 mA	1.0	+1.9	+1.9	+1.9	ns
	T _{OLVTTTL_S16}	16 mA	0.9	+1.7	+1.7	+1.7	ns
	T _{OLVTTTL_S24}	24 mA	0.8	+1.3	+1.3	+1.3	ns
	T _{OLVTTTL_F2}	LVTTTL, Fast, 2 mA	1.9	+13.1	+13.1	+13.1	ns
	T _{OLVTTTL_F4}	4 mA	0.7	+5.3	+5.3	+5.3	ns
	T _{OLVTTTL_F6}	6 mA	0.20	+3.1	+3.1	+3.1	ns
	T _{OLVTTTL_F8}	8 mA	0.10	+1.0	+1.0	+1.0	ns
	T _{OLVTTTL_F12}	12 mA	0.0	0.0	0.0	0.0	ns
	T _{OLVTTTL_F16}	16 mA	-0.10	-0.05	-0.05	-0.05	ns
	T _{OLVTTTL_F24}	24 mA	-0.10	-0.20	-0.20	-0.20	ns
	T _{OLVCMOS_2}	LVC MOS2	0.10	+0.09	+0.09	+0.09	ns
	T _{OLVCMOS_18}	LVC MOS18	0.10	+0.7	+0.7	+0.7	ns
	T _{OLVDS}	LVDS	-0.39	-1.2	-1.2	-1.2	ns
	T _{OLVPECL}	LVPECL	-0.20	-0.41	-0.41	-0.41	ns
	T _{OPCI33_3}	PCI, 33 MHz, 3.3 V	0.50	+2.3	+2.3	+2.3	ns
	T _{OPCI66_3}	PCI, 66 MHz, 3.3 V	0.10	-0.41	-0.41	-0.41	ns
	T _{OGTL}	GTL	0.6	+0.49	+0.49	+0.49	ns
	T _{OGTLP}	GTL+	0.7	+0.8	+0.8	+0.8	ns
	T _{OHSTL_I}	HSTL I	0.10	-0.51	-0.51	-0.51	ns
	T _{OHSTL_III}	HSTL III	-0.10	-0.91	-0.91	-0.91	ns
	T _{OHSTL_IV}	HSTL IV	-0.20	-1.01	-1.01	-1.01	ns
	T _{OSSTL2_I}	SSTL2 I	-0.10	-0.51	-0.51	-0.51	ns
	T _{OSSTL2_II}	SSTL2 II	-0.20	-0.91	-0.91	-0.91	ns
T _{OSSTL3_I}	SSTL3 I	-0.20	-0.51	-0.51	-0.51	ns	
T _{OSSTL3_II}	SSTL3 II	-0.30	-1.01	-1.01	-1.01	ns	
T _{OCTT}	CTT	0.0	-0.61	-0.61	-0.61	ns	
T _{OAGP}	AGP	-0.1	-0.91	-0.91	-0.91	ns	

Calculation of $T_{i\text{oop}}$ as a Function of Capacitance

$T_{i\text{oop}}$ is the propagation delay from the O Input of the IOB to the pad. The values for $T_{i\text{oop}}$ are based on the standard capacitive load (C_{sl}) for each I/O standard as listed in [Table 2](#).

Table 2: Constants for Use in Calculation of $T_{i\text{oop}}$

Standard	C_{sl} (pF)	fl (ns/pF)
LVTTTL Fast Slew Rate, 2mA drive	35	0.41
LVTTTL Fast Slew Rate, 4mA drive	35	0.20
LVTTTL Fast Slew Rate, 6mA drive	35	0.13
LVTTTL Fast Slew Rate, 8mA drive	35	0.079
LVTTTL Fast Slew Rate, 12mA drive	35	0.044
LVTTTL Fast Slew Rate, 16mA drive	35	0.043
LVTTTL Fast Slew Rate, 24mA drive	35	0.033
LVTTTL Slow Slew Rate, 2mA drive	35	0.41
LVTTTL Slow Slew Rate, 4mA drive	35	0.20
LVTTTL Slow Slew Rate, 6mA drive	35	0.10
LVTTTL Slow Slew Rate, 8mA drive	35	0.086
LVTTTL Slow Slew Rate, 12mA drive	35	0.058
LVTTTL Slow Slew Rate, 16mA drive	35	0.050
LVTTTL Slow Slew Rate, 24mA drive	35	0.048
LVC MOS2	35	0.041
LVC MOS18	35	0.050
PCI 33 MHz 3.3 V	10	0.050
PCI 66 MHz 3.3 V	10	0.033
GTL	0	0.014
GTL+	0	0.017
HSTL Class I	20	0.022
HSTL Class III	20	0.016
HSTL Class IV	20	0.014
SSTL2 Class I	30	0.028
SSTL2 Class II	30	0.016
SSTL3 Class I	30	0.029
SSTL3 Class II	30	0.016
CTT	20	0.035
AGP	10	0.037

Notes:

- I/O parameter measurements are made with the capacitance values shown above. See the [Application Examples](#) for appropriate terminations.
- I/O standard measurements are reflected in the IBIS model information except where the IBIS format precludes it.

For other capacitive loads, use the formulas below to calculate the corresponding $T_{i\text{oop}}$.

$$T_{i\text{oop}} = T_{i\text{oop}} + T_{\text{opadjust}} + (C_{\text{load}} - C_{sl}) * fl$$

where:

T_{opadjust} is reported above in the Output Delay Adjustment section.

C_{load} is the capacitive load for the design.

Table 3: Delay Measurement Methodology

Standard	V_L^1	V_H^1	Meas. Point	V_{REF} (Typ) ²
LVTTTL	0	3	1.4	-
LVC MOS2	0	2.5	1.125	-
PCI33_3	Per PCI Spec			-
PCI66_3	Per PCI Spec			-
GTL	$V_{REF} - 0.2$	$V_{REF} + 0.2$	V_{REF}	0.80
GTL+	$V_{REF} - 0.2$	$V_{REF} + 0.2$	V_{REF}	1.0
HSTL Class I	$V_{REF} - 0.5$	$V_{REF} + 0.5$	V_{REF}	0.75
HSTL Class III	$V_{REF} - 0.5$	$V_{REF} + 0.5$	V_{REF}	0.90
HSTL Class IV	$V_{REF} - 0.5$	$V_{REF} + 0.5$	V_{REF}	0.90
SSTL3 I & II	$V_{REF} - 1.0$	$V_{REF} + 1.0$	V_{REF}	1.5
SSTL2 I & II	$V_{REF} - 0.75$	$V_{REF} + 0.75$	V_{REF}	1.25
CTT	$V_{REF} - 0.2$	$V_{REF} + 0.2$	V_{REF}	1.5
AGP	$V_{REF} - (0.2 \times V_{CC0})$	$V_{REF} + (0.2 \times V_{CC0})$	V_{REF}	Per AGP Spec
LVDS	$1.2 - 0.125$	$1.2 + 0.125$	1.2	
LVPECL	$1.6 - 0.3$	$1.6 + 0.3$	1.6	

Notes:

- Input waveform switches between V_L and V_H .
- Measurements are made at V_{REF} (Typ), Maximum, and Minimum. Worst-case values are reported.
I/O parameter measurements are made with the capacitance values shown in [Table 2](#). See the [Application Examples](#) for appropriate terminations.
I/O standard measurements are reflected in the IBIS model information except where the IBIS format precludes it.

Clock Distribution Switching Characteristics

Description	Symbol	Speed Grade				Units
		Min	-8	-7	-6	
GCLK IOB and Buffer						
Global Clock PAD to output.	T _{GPI} O	0.38	0.7	0.7	0.7	ns, max
Global Clock Buffer I input to O output	T _{GPI} O	0.11	0.19	0.45	0.50	ns, max

I/O Standard Global Clock Input Adjustments

Description ⁽¹⁾	Symbol	Standard	Speed Grade				Units
			Min	-8	-7	-6	
Data Input Delay Adjustments							
Standard-specific global clock input delay adjustments	T _{GPLVTTL}	LVTTTL	0.0	0.0	0.0	0.0	ns, max
	T _{GPLVCMOS2}	LVCOS2	-0.02	0.0	0.0	0.0	ns, max
	T _{GPLVCMOS18}	LVCOS2	0.12	0.20	0.20	0.20	ns, max
	T _{GLVDS}	LVDS	0.23	0.38	0.38	0.38	ns, max
	T _{GLVPECL}	LVPECL	0.23	0.38	0.38	0.38	ns, max
	T _{GPPCI33_3}	PCI, 33 MHz, 3.3 V	-0.05	0.08	0.08	0.08	ns, max
	T _{GPPCI66_3}	PCI, 66 MHz, 3.3 V	-0.05	-0.11	-0.11	-0.11	ns, max
	T _{GPGTL}	GTL	0.20	0.37	0.37	0.37	ns, max
	T _{GPGTLP}	GTL+	0.20	0.37	0.37	0.37	ns, max
	T _{GPHSTL}	HSTL	0.18	0.27	0.27	0.27	ns, max
	T _{GPSSTL2}	SSTL2	0.21	0.27	0.27	0.27	ns, max
	T _{GPSSTL3}	SSTL3	0.18	0.27	0.27	0.27	ns, max
	T _{GPCTT}	CTT	0.22	0.33	0.33	0.33	ns, max
T _{GPAGP}	AGP	0.21	0.27	0.27	0.27	ns, max	

Notes:

1. Input timing for GPLVTTL is measured at 1.4 V. For other I/O standards, see [Table 3](#).

CLB Switching Characteristics

Delays originating at F/G inputs vary slightly according to the input used, see [Figure 2](#). The values listed below are worst-case. Precise values are provided by the timing analyzer.

Description ⁽¹⁾	Symbol	Speed Grade				Units
		Min	-8	-7	-6	
Combinatorial Delays						
4-input function: F/G inputs to X/Y outputs	T_{ILO}	0.19	0.40	0.42	0.47	ns, max
5-input function: F/G inputs to F5 output	T_{IF5}	0.36	0.76	0.8	0.9	ns, max
5-input function: F/G inputs to X output	T_{IF5X}	0.35	0.74	0.8	0.9	ns, max
6-input function: F/G inputs to Y output via F6 MUX	T_{IF6Y}	0.35	0.74	0.9	1.0	ns, max
6-input function: F5IN input to Y output	T_{F5INY}	0.04	0.11	0.20	0.22	ns, max
Incremental delay routing through transparent latch to XQ/YQ outputs	T_{IFNCTL}	0.27	0.63	0.7	0.8	ns, max
BY input to YB output	T_{BYYB}	0.19	0.38	0.46	0.51	ns, max
Sequential Delays						
FF Clock CLK to XQ/YQ outputs	T_{CKO}	0.34	0.78	0.9	1.0	ns, max
Latch Clock CLK to XQ/YQ outputs	T_{CKLO}	0.40	0.77	0.9	1.0	ns, max
Setup and Hold Times before/after Clock CLK						
4-input function: F/G Inputs	T_{ICK} / T_{CKI}	0.39 / 0	0.9 / 0	1.0 / 0	1.1 / 0	ns, min
5-input function: F/G inputs	T_{IF5CK} / T_{CKIF5}	0.55 / 0	1.3 / 0	1.4 / 0	1.5 / 0	ns, min
6-input function: F5IN input	T_{F5INCK} / T_{CKF5IN}	0.27 / 0	0.6 / 0	0.8 / 0	0.8 / 0	ns, min
6-input function: F/G inputs via F6 MUX	T_{IF6CK} / T_{CKIF6}	0.58 / 0	1.3 / 0	1.5 / 0	1.6 / 0	ns, min
BX/BY inputs	T_{DICK} / T_{CKDI}	0.25 / 0	0.6 / 0	0.7 / 0	0.8 / 0	ns, min
CE input	T_{CECK} / T_{CKCE}	0.28 / 0	0.55 / 0	0.7 / 0	0.7 / 0	ns, min
SR/BY inputs (synchronous)	T_{RCK} / T_{CKR}	0.24 / 0	0.46 / 0	0.52 / 0	0.6 / 0	ns, min
Clock CLK						
Minimum Pulse Width, High	T_{CH}	0.56	1.2	1.3	1.4	ns, min
Minimum Pulse Width, Low	T_{CL}	0.56	1.2	1.3	1.4	ns, min
Set/Reset						
Minimum Pulse Width, SR/BY inputs	T_{RPW}	0.94	1.9	2.1	2.4	ns, min
Delay from SR/BY inputs to XQ/YQ outputs (asynchronous)	T_{RQ}	0.39	0.8	0.9	1.0	ns, max
Toggle Frequency (MHz) (for export control)	F_{TOG}	-	416	400	357	MHz

Notes:

1. A Zero "0" Hold Time listing indicates no hold time or a negative hold time. Negative values can not be guaranteed "best-case", but if a "0" is listed, there is no positive hold time.

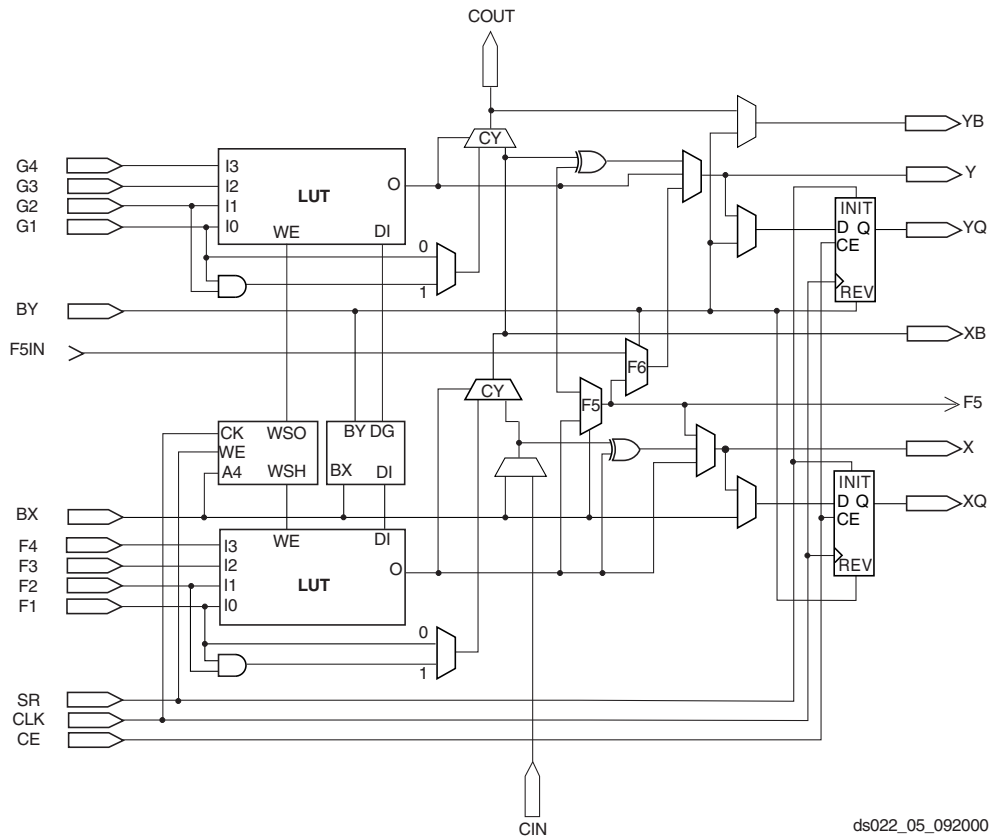

Figure 2: Detailed View of Virtex-E Slice

ds022_05_092000

CLB Arithmetic Switching Characteristics

Setup times not listed explicitly can be approximated by decreasing the combinatorial delays by the setup time adjustment listed. Precise values are provided by the timing analyzer.

Description ⁽¹⁾	Symbol	Speed Grade				Units
		Min	-8	-7	-6	
Combinatorial Delays						
F operand inputs to X via XOR	T _{OPX}	0.32	0.68	0.8	0.8	ns, max
F operand input to XB output	T _{OPXB}	0.35	0.65	0.8	0.9	ns, max
F operand input to Y via XOR	T _{OPY}	0.59	1.07	1.4	1.5	ns, max
F operand input to YB output	T _{OPYB}	0.48	0.89	1.1	1.3	ns, max
F operand input to COUT output	T _{OPCYF}	0.37	0.71	0.9	1.0	ns, max
G operand inputs to Y via XOR	T _{OPGY}	0.34	0.72	0.8	0.9	ns, max
G operand input to YB output	T _{OPGYB}	0.47	0.78	1.2	1.3	ns, max
G operand input to COUT output	T _{OPCYG}	0.36	0.60	0.9	1.0	ns, max
BX initialization input to COUT	T _{BXCY}	0.19	0.36	0.51	0.57	ns, max
CIN input to X output via XOR	T _{CINX}	0.27	0.50	0.6	0.7	ns, max
CIN input to XB	T _{CINXB}	0.02	0.04	0.07	0.08	ns, max
CIN input to Y via XOR	T _{CINY}	0.26	0.45	0.7	0.7	ns, max
CIN input to YB	T _{CINYB}	0.16	0.28	0.38	0.43	ns, max
CIN input to COUT output	T _{BYP}	0.05	0.10	0.14	0.15	ns, max
Multiplier Operation						
F1/2 operand inputs to XB output via AND	T _{FANDXB}	0.10	0.30	0.35	0.39	ns, max
F1/2 operand inputs to YB output via AND	T _{FANDYB}	0.28	0.56	0.7	0.8	ns, max
F1/2 operand inputs to COUT output via AND	T _{FANDCY}	0.17	0.38	0.46	0.51	ns, max
G1/2 operand inputs to YB output via AND	T _{GANDYB}	0.20	0.46	0.55	0.7	ns, max
G1/2 operand inputs to COUT output via AND	T _{GANDCY}	0.09	0.28	0.30	0.34	ns, max
Setup and Hold Times before/after Clock CLK						
CIN input to FFX	T _{CCKX} /T _{CKCX}	0.47 / 0	1.0 / 0	1.2 / 0	1.3 / 0	ns, min
CIN input to FFY	T _{CCKY} /T _{CKCY}	0.49 / 0	0.92 / 0	1.2 / 0	1.3 / 0	ns, min

Notes:

1. A Zero "0" Hold Time listing indicates no hold time or a negative hold time. Negative values can not be guaranteed "best-case", but if a "0" is listed, there is no positive hold time.

CLB Distributed RAM Switching Characteristics

Description ⁽¹⁾	Symbol	Speed Grade				Units
		Min	-8	-7	-6	
Sequential Delays						
Clock CLK to X/Y outputs (WE active) 16 x 1 mode	T _{SHCKO16}	0.67	1.38	1.5	1.7	ns, max
Clock CLK to X/Y outputs (WE active) 32 x 1 mode	T _{SHCKO32}	0.84	1.66	1.9	2.1	ns, max
Shift-Register Mode						
Clock CLK to X/Y outputs	T _{REG}	1.25	2.39	2.9	3.2	ns, max
Setup and Hold Times before/after Clock CLK						
F/G address inputs	T _{AS} /T _{AH}	0.19 / 0	0.38 / 0	0.42 / 0	0.47 / 0	ns, min
BX/BY data inputs (DIN)	T _{DS} /T _{DH}	0.44 / 0	0.87 / 0	0.97 / 0	1.09 / 0	ns, min
SR input (WE)	T _{WS} /T _{WH}	0.29 / 0	0.57 / 0	0.7 / 0	0.8 / 0	ns, min
Clock CLK						
Minimum Pulse Width, High	T _{WPH}	0.96	1.9	2.1	2.4	ns, min
Minimum Pulse Width, Low	T _{WPL}	0.96	1.9	2.1	2.4	ns, min
Minimum clock period to meet address write cycle time	T _{WC}	1.92	3.8	4.2	4.8	ns, min
Shift-Register Mode						
Minimum Pulse Width, High	T _{SRPH}	1.0	1.9	2.1	2.4	ns, min
Minimum Pulse Width, Low	T _{SRPL}	1.0	1.9	2.1	2.4	ns, min

Notes:

1. A Zero "0" Hold Time listing indicates no hold time or a negative hold time. Negative values can not be guaranteed "best-case", but if a "0" is listed, there is no positive hold time.

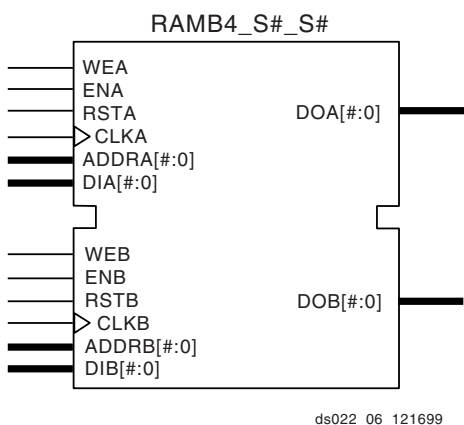

Figure 3: Dual-Port Block SelectRAM

Block RAM Switching Characteristics

Description ⁽¹⁾	Symbol	Speed Grade				Units
		Min	-8	-7	-6	
Sequential Delays						
Clock CLK to DOUT output	T_{BCKO}	0.63	2.46	3.1	3.5	ns, max
Setup and Hold Times before Clock CLK						
ADDR inputs	T_{BACK}/T_{BCKA}	0.42 / 0	0.9 / 0	1.0 / 0	1.1 / 0	ns, min
DIN inputs	T_{BDCK}/T_{BCKD}	0.42 / 0	0.9 / 0	1.0 / 0	1.1 / 0	ns, min
EN input	T_{BECK}/T_{BCKE}	0.97 / 0	2.0 / 0	2.2 / 0	2.5 / 0	ns, min
RST input	T_{BRCK}/T_{BCKR}	0.9 / 0	1.8 / 0	2.1 / 0	2.3 / 0	ns, min
WEN input	T_{BWCK}/T_{BCKW}	0.86 / 0	1.7 / 0	2.0 / 0	2.2 / 0	ns, min
Clock CLK						
Minimum Pulse Width, High	T_{BPWH}	0.6	1.2	1.35	1.5	ns, min
Minimum Pulse Width, Low	T_{BPWL}	0.6	1.2	1.35	1.5	ns, min
CLKA -> CLKB setup time for different ports	T_{BCCS}	1.2	2.4	2.7	3.0	ns, min

Notes:

1. A Zero "0" Hold Time listing indicates no hold time or a negative hold time. Negative values can not be guaranteed "best-case", but if a "0" is listed, there is no positive hold time.

TBUF Switching Characteristics

Description	Symbol	Speed Grade				Units
		Min	-8	-7	-6	
Combinatorial Delays						
IN input to OUT output	T_{IO}	0.0	0.0	0.0	0.0	ns, max
TRI input to OUT output high-impedance	T_{OFF}	0.05	0.092	0.10	0.11	ns, max
TRI input to valid data on OUT output	T_{ON}	0.05	0.092	0.10	0.11	ns, max

JTAG Test Access Port Switching Characteristics

Description	Symbol	Value	Units
TMS and TDI Setup times before TCK	T_{TAPTK}	4.0	ns, min
TMS and TDI Hold times after TCK	T_{TCKTAP}	2.0	ns, min
Output delay from clock TCK to output TDO	T_{TCKTDO}	11.0	ns, max
Maximum TCK clock frequency	F_{TCK}	33	MHz, max

Virtex-E Pin-to-Pin Output Parameter Guidelines

All devices are 100% functionally tested. Listed below are representative values for typical pin locations and normal clock loading. Values are expressed in nanoseconds unless otherwise noted.

Global Clock Input to Output Delay for LVTTL, 12 mA, Fast Slew Rate, *with* DLL

Description ⁽¹⁾	Symbol	Device ⁽³⁾	Speed Grade ⁽²⁾				Units
			Min	-8	-7	-6	
LVTTL Global Clock Input to Output Delay using Output Flip-flop, 12 mA, Fast Slew Rate, <i>with</i> DLL. For data <i>output</i> with different standards, adjust the delays with the values shown in “IOB Output Switching Characteristics Standard Adjustments” on page 8.	T _{ICKOFDLL}	XCV405E	1.0	3.1	3.1	3.1	ns
		XCV812E	1.0	3.1	3.1	3.1	ns

Notes:

1. Listed above are representative values where one global clock input drives one vertical clock line in each accessible column, and where all accessible IOB and CLB flip-flops are clocked by the global clock net.
2. Output timing is measured at 50% V_{CC} threshold with 35 pF external capacitive load. For other I/O standards and different loads, see [Table 2](#) and [Table 3](#).
3. DLL output jitter is already included in the timing calculation.

Global Clock Input to Output Delay for LVTTL, 12 mA, Fast Slew Rate, *without* DLL

Description ⁽¹⁾	Symbol	Device	Speed Grade ⁽²⁾				Units
			Min	-8	-7	-6	
LVTTL Global Clock Input to Output Delay using Output Flip-flop, 12 mA, Fast Slew Rate, <i>without</i> DLL. For data <i>output</i> with different standards, adjust the delays with the values shown in “IOB Output Switching Characteristics Standard Adjustments” on page 8.	T _{ICKOF}	XCV405E	1.6	4.5	4.7	4.9	ns
		XCV812E	1.8	4.8	5.0	5.2	ns

Notes:

1. Listed above are representative values where one global clock input drives one vertical clock line in each accessible column, and where all accessible IOB and CLB flip-flops are clocked by the global clock net.
2. Output timing is measured at 50% V_{CC} threshold with 35 pF external capacitive load. For other I/O standards and different loads, see [Table 2](#) and [Table 3](#).

Virtex-E Pin-to-Pin Input Parameter Guidelines

All devices are 100% functionally tested. Listed below are representative values for typical pin locations and normal clock loading. Values are expressed in nanoseconds unless otherwise noted.

Global Clock Set-Up and Hold for LVTTTL Standard, *with* DLL

Description ⁽¹⁾	Symbol	Device ⁽³⁾	Speed Grade ⁽²⁾				Units
			Min	-8	-7	-6	
Input Setup and Hold Time Relative to Global Clock Input Signal for LVTTTL Standard. For data input with different standards, adjust the setup time delay by the values shown in “IOB Input Switching Characteristics Standard Adjustments” on page 6.							
No Delay	T_{PSDLL}/T_{PHDLL}	XCV405E	1.5 / -0.4	1.5 / -0.4	1.6 / -0.4	1.7 / -0.4	ns
Global Clock and IFF, with DLL		XCV812E	1.5 / -0.4	1.5 / -0.4	1.6 / -0.4	1.7 / -0.4	ns

Notes:

1. IFF = Input Flip-Flop or Latch
2. Setup time is measured relative to the Global Clock input signal with the fastest route and the lightest load. Hold time is measured relative to the Global Clock input signal with the slowest route and heaviest load.
3. DLL output jitter is already included in the timing calculation.

Global Clock Set-Up and Hold for LVTTTL Standard, *without* DLL

Description ⁽¹⁾	Symbol	Device ⁽³⁾	Speed Grade ⁽²⁾				Units
			Min	-8	-7	-6	
Input Setup and Hold Time Relative to Global Clock Input Signal for LVTTTL Standard. For data input with different standards, adjust the setup time delay by the values shown in “IOB Input Switching Characteristics Standard Adjustments” on page 6.							
Full Delay	T_{PSFD}/T_{PHFD}	XCV405E	2.3 / 0	2.3 / 0	2.3 / 0	2.3 / 0	ns
Global Clock and IFF, without DLL		XCV812E	2.5 / 0	2.5 / 0	2.5 / 0	2.5 / 0	ns

Notes:

1. IFF = Input Flip-Flop or Latch
2. Setup time is measured relative to the Global Clock input signal with the fastest route and the lightest load. Hold time is measured relative to the Global Clock input signal with the slowest route and heaviest load.
3. A Zero “0” Hold Time listing indicates no hold time or a negative hold time. Negative values can not be guaranteed “best-case”, but if a “0” is listed, there is no positive hold time.

DLL Timing Parameters

All devices are 100 percent functionally tested. Because of the difficulty in directly measuring many internal timing parameters, those parameters are derived from benchmark timing patterns. The following guidelines reflect worst-case values across the recommended operating conditions.

Description	Symbol	F_{CLKIN}	Speed Grade						Units
			-8		-7		-6		
			Min	Max	Min	Max	Min	Max	
Input Clock Frequency (CLKDLLHF)	FCLKINHF		60	320	60	320	60	260	MHz
Input Clock Frequency (CLKDLL)	FCLKINLF		25	160	25	160	25	135	MHz
Input Clock Low/High Pulse Width	T_{DLLPW}	≥ 25 MHz	5.0		5.0		5.0		ns
		≥ 50 MHz	3.0		3.0		3.0		ns
		≥ 100 MHz	2.4		2.4		2.4		ns
		≥ 150 MHz	2.0		2.0		2.0		ns
		≥ 200 MHz	1.8		1.8		1.8		ns
		≥ 250 MHz	1.5		1.5		1.5		ns
		≥ 300 MHz	1.3		1.3		NA	ns	

Period Tolerance: the allowed input clock period change in nanoseconds.

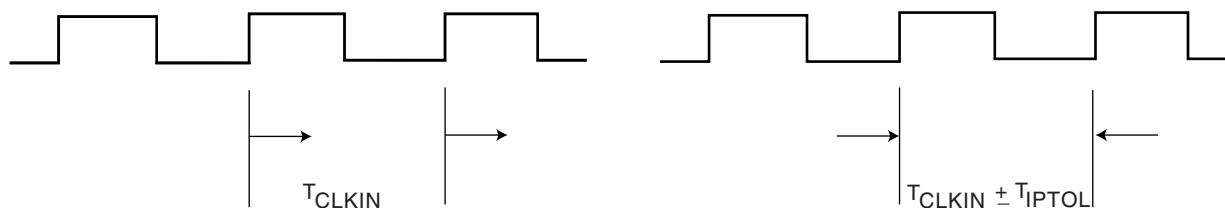

Output Jitter: the difference between an ideal reference clock edge and the actual design.

Phase Offset and Maximum Phase Difference

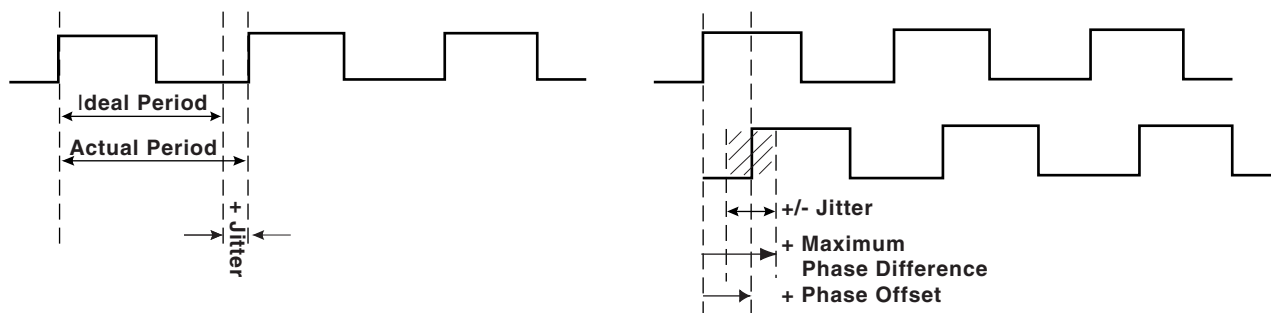

ds022_24_091200

Figure 4: DLL Timing Waveforms

DLL Clock Tolerance, Jitter, and Phase Information

All DLL output jitter and phase specifications determined through statistical measurement at the package pins using a clock mirror configuration and matched drivers.

Description	Symbol	F _{CLKIN}	CLKDLLHF		CLKDLL		Units
			Min	Max	Min	Max	
Input Clock Period Tolerance	T _{IPTOL}		-	1.0	-	1.0	ns
Input Clock Jitter Tolerance (Cycle to Cycle)	T _{IJITCC}		-	± 150	-	± 300	ps
Time Required for DLL to Acquire Lock ⁽⁶⁾	T _{LOCK}	> 60 MHz	-	20	-	20	µs
		50 - 60 MHz	-	-	-	25	µs
		40 - 50 MHz	-	-	-	50	µs
		30 - 40 MHz	-	-	-	90	µs
		25 - 30 MHz	-	-	-	120	µs
Output Jitter (cycle-to-cycle) for any DLL Clock Output ⁽¹⁾	T _{OJITCC}			± 60		± 60	ps
Phase Offset between CLKIN and CLKO ⁽²⁾	T _{PHIO}			± 100		± 100	ps
Phase Offset between Clock Outputs on the DLL ⁽³⁾	T _{PHOO}			± 140		± 140	ps
Maximum Phase Difference between CLKIN and CLKO ⁽⁴⁾	T _{PHIOM}			± 160		± 160	ps
Maximum Phase Difference between Clock Outputs on the DLL ⁽⁵⁾	T _{PHOOM}			± 200		± 200	ps

Notes:

- Output Jitter** is cycle-to-cycle jitter measured on the DLL output clock and is based on a maximum tap delay resolution, *excluding* input clock jitter.
- Phase Offset between CLKIN and CLKO** is the worst-case fixed time difference between rising edges of CLKIN and CLKO, *excluding* Output Jitter and input clock jitter.
- Phase Offset between Clock Outputs on the DLL** is the worst-case fixed time difference between rising edges of any two DLL outputs, *excluding* Output Jitter and input clock jitter.
- Maximum Phase Difference between CLKIN and CLKO** is the sum of Output Jitter and Phase Offset between CLKIN and CLKO, or the greatest difference between CLKIN and CLKO rising edges due to DLL alone (*excluding* input clock jitter).
- Maximum Phase Difference between Clock Outputs on the DLL** is the sum of Output Jitter and Phase Offset between any two DLL clock outputs, or the greatest difference between any two DLL output rising edges due to DLL alone (*excluding* input clock jitter).
- Add 30% to the value for Industrial grade parts.

Revision History

The following table shows the revision history for this document.

Date	Version	Revision
03/23/2000	1.0	Initial Xilinx release.
08/01/2000	1.1	Accumulated edits and fixes. Upgrade to Preliminary. Preview -8 numbers added. Reformatted to adhere to corporate documentation style guidelines. Minor changes in BG560 pin-out table.
09/19/2000	1.2	<ul style="list-style-type: none"> In Table 3 (Module 4), FG676 Fine-Pitch BGA — XCV405E, the following pins are no longer labeled as VREF: B7, G16, G26, W26, AF20, AF8, Y1, H1. Min values added to Virtex-E Electrical Characteristics tables.

Date	Version	Revision
11/20/2000	1.3	<ul style="list-style-type: none"> Updated speed grade -8 numbers in Virtex-E Electrical Characteristics tables (Module 3). Updated minimums in Table 11 (Module 2), and added notes to Table 12 (Module 2). Added to note 2 of Absolute Maximum Ratings (Module 3). Changed all minimum hold times to -0.4 for Global Clock Set-Up and Hold for LVTTL Standard, with DLL (Module 3). Revised maximum T_{DLLPW} in -6 speed grade for DLL Timing Parameters (Module 3).
04/02/2001	1.4	<ul style="list-style-type: none"> In Table 4, FG676 Fine-Pitch BGA — XCV405E, pin B19 is no longer labeled as VREF, and pin G16 is now labeled as VREF. Updated values in Virtex-E Switching Characteristics tables. Converted data sheet to modularized format. See the Virtex-E Extended Memory Data Sheet section.
04/19/2001	1.5	<ul style="list-style-type: none"> Updated values in Virtex-E Switching Characteristics tables.
07/23/2001	1.6	<ul style="list-style-type: none"> Under Absolute Maximum Ratings, changed (T_{SOL}) to 220 °C . Changes made to SSTL symbol names in IOB Input Switching Characteristics Standard Adjustments table.
07/26/2001	1.7	<ul style="list-style-type: none"> Removed T_{SOL} parameter and added footnote to Absolute Maximum Ratings table.
09/18/2001	1.8	<ul style="list-style-type: none"> Reworded power supplies footnote to Absolute Maximum Ratings table.
10/25/2001	1.9	<ul style="list-style-type: none"> Updated the speed grade designations used in data sheets, and added Table 1, which shows the current speed grade designation for each device. Updated Power-On Power Supply Requirements table.
11/09/2001	2.0	<ul style="list-style-type: none"> Updated the XCV405E device speed grade designation to Preliminary in Table 1. Updated Power-On Power Supply Requirements table.
02/01/2002	2.1	<ul style="list-style-type: none"> Updated footnotes to the DC Input and Output Levels and DLL Clock Tolerance, Jitter, and Phase Information tables.
07/17/2002	2.2	<ul style="list-style-type: none"> Data sheet designation upgraded from Preliminary to Production. Removed mention of MIL-M-38510/605 specification. Added link to XAPP158 from the Power-On Power Supply Requirements section.
09/10/2002	2.3	<ul style="list-style-type: none"> Revised V_{IN} in Absolute Maximum Ratings Table. Added Clock CLK switching characteristics to “IOB Input Switching Characteristics” on page 5 and “IOB Output Switching Characteristics, Figure 1” on page 7.
12/22/2002	2.3.1	<ul style="list-style-type: none"> Added footnote regarding V_{IN} PCI compliance to Absolute Maximum Ratings table.
03/14/2003	2.3.2	<ul style="list-style-type: none"> Under Power-On Power Supply Requirements, the fastest ramp rate is no longer a "suggested" rate.
03/21/2014	3.0	<ul style="list-style-type: none"> This product is obsolete/discontinued per XCN12026.

Virtex-E Extended Memory Data Sheet

The Virtex-E Extended Memory Data Sheet contains the following modules:

- DS025-1, Virtex-E 1.8V Extended Memory FPGAs: Introduction and Ordering Information (Module 1)
- DS025-2, Virtex-E 1.8V Extended Memory FPGAs: Functional Description (Module 2)
- DS025-3, Virtex-E 1.8V Extended Memory FPGAs: DC and Switching Characteristics (Module 3)
- DS025-4, Virtex-E 1.8V Extended Memory FPGAs: Pinout Tables (Module 4)



Virtex™-E 1.8 V Extended Memory Field Programmable Gate Arrays

DS025-4 (v3.0) March 21, 2014

Production Product Specification

Virtex-E Pin Definitions

Pin Name	Dedicated Pin	Direction	Description
GCK0, GCK1, GCK2, GCK3	Yes	Input	Clock input pins that connect to Global Clock Buffers. These pins become user inputs when not needed for clocks.
M0, M1, M2	Yes	Input	Mode pins are used to specify the configuration mode.
CCLK	Yes	Input or Output	The configuration Clock I/O pin: it is an input for SelectMAP and slave-serial modes, and output in master-serial mode. After configuration, it is input only, logic level = Don't Care.
PROGRAM	Yes	Input	Initiates a configuration sequence when asserted Low.
DONE	Yes	Bidirectional	Indicates that configuration loading is complete, and that the start-up sequence is in progress. The output can be open drain.
INIT	No	Bidirectional (Open-drain)	When Low, indicates that the configuration memory is being cleared. The pin becomes a user I/O after configuration.
BUSY/DOUT	No	Output	In SelectMAP mode, BUSY controls the rate at which configuration data is loaded. The pin becomes a user I/O after configuration unless the SelectMAP port is retained. In bit-serial modes, DOUT provides preamble and configuration data to downstream devices in a daisy-chain. The pin becomes a user I/O after configuration.
D0/DIN, D1, D2, D3, D4, D5, D6, D7	No	Input or Output	In SelectMAP mode, D0-7 are configuration data pins. These pins become user I/Os after configuration unless the SelectMAP port is retained. In bit-serial modes, DIN is the single data input. This pin becomes a user I/O after configuration.
WRITE	No	Input	In SelectMAP mode, the active-low Write Enable signal. The pin becomes a user I/O after configuration unless the SelectMAP port is retained.
CS	No	Input	In SelectMAP mode, the active-low Chip Select signal. The pin becomes a user I/O after configuration unless the SelectMAP port is retained.
TDI, TDO, TMS, TCK	Yes	Mixed	Boundary-scan Test-Access-Port pins, as defined in IEEE1149.1.
DXN, DXP	Yes	N/A	Temperature-sensing diode pins. (Anode: DXP, cathode: DXN)
V _{CCINT}	Yes	Input	Power-supply pins for the internal core logic.
V _{CCO}	Yes	Input	Power-supply pins for the output drivers (subject to banking rules)
V _{REF}	No	Input	Input threshold voltage pins. Become user I/Os when an external threshold voltage is not needed (subject to banking rules).
GND	Yes	Input	Ground

© 2000-2014 Xilinx, Inc. All rights reserved. All Xilinx trademarks, registered trademarks, patents, and disclaimers are as listed at <http://www.xilinx.com/legal.htm>. All other trademarks and registered trademarks are the property of their respective owners. All specifications are subject to change without notice.

BG560 Ball Grid Array Packages

XCV405E and the XCV812E Virtex-E Extended Memory devices are available in the BG560 BGA package. Pins labeled IO_VREF can be used as either in all parts unless device-dependent as indicated in the footnotes. If the pin is not used as V_{REF} it can be used as general I/O. Immediately following Table 1, see Table 2 for BG560 package Differential Pair information.

Table 1: **BG560 BGA — XCV405E and XCV812E**

Bank	Pin Description	Pin#
0	GCK3	A17
0	IO	A27
0	IO	B25
0	IO	C28
0	IO	C30
0	IO	D30
0	IO	E18
0	IO_L0N	E28
0	IO_L0P	D29
0	IO_L1N_YY	D28
0	IO_L1P_YY	A31
0	IO_VREF_L2N_YY	E27
0	IO_L2P_YY	C29
0	IO_L3N_Y	B30
0	IO_L3P_Y	D27
0	IO_L4N_YY	E26
0	IO_L4P_YY	B29
0	IO_VREF_L5N_YY	D26
0	IO_L5P_YY	C27
0	IO_L6N	E25
0	IO_L6P	A28
0	IO_L7N_YY	D25
0	IO_L7P_YY	C26
0	IO_VREF_L8N_YY	E24 ¹
0	IO_L8P_YY	B26
0	IO_L9N_Y	C25
0	IO_L9P_Y	D24
0	IO_VREF_L10N_YY	E23
0	IO_L10P_YY	A25
0	IO_L11N_YY	D23

Table 1: **BG560 BGA — XCV405E and XCV812E**

Bank	Pin Description	Pin#
0	IO_L11P_YY	B24
0	IO_L12N	E22
0	IO_L12P	C23
0	IO_L13N_YY	A23
0	IO_L13P_YY	D22
0	IO_VREF_L14N_YY	E21 ¹
0	IO_L14P_YY	B22
0	IO_L15N_Y	D21
0	IO_L15P_Y	C21
0	IO_L16N_YY	B21
0	IO_L16P_YY	E20
0	IO_VREF_L17N_YY	D20
0	IO_L17P_YY	C20
0	IO_L18N	B20
0	IO_L18P	E19
0	IO_L19N_YY	D19
0	IO_L19P_YY	C19
0	IO_VREF_L20N_YY	A19
0	IO_L20P_YY	D18
0	IO_LVDS_DLL_L21N	C18
1	GCK2	D17
1	IO	A3
1	IO	D9
1	IO	E8
1	IO	E11
1	IO_LVDS_DLL_L21P	E17
1	IO_L22N_Y	C17
1	IO_L22P_Y	B17
1	IO_L23N_YY	B16
1	IO_VREF_L23P_YY	D16
1	IO_L24N_YY	E16
1	IO_L24P_YY	C16
1	IO_L25N	A15
1	IO_L25P	C15
1	IO_L26N_YY	D15
1	IO_VREF_L26P_YY	E15

Table 1: BG560 BGA — XCV405E and XCV812E

Bank	Pin Description	Pin#
1	IO_L27N_YY	C14
1	IO_L27P_YY	D14
1	IO_L28N_Y	A13
1	IO_L28P_Y	E14
1	IO_L29N_YY	C13
1	IO_VREF_L29P_YY	D13 ¹
1	IO_L30N_YY	C12
1	IO_L30P_YY	E13
1	IO_L31N	A11
1	IO_L31P	D12
1	IO_L32N_YY	B11
1	IO_L32P_YY	C11
1	IO_L33N_YY	B10
1	IO_VREF_L33P_YY	D11
1	IO_L34N	C10
1	IO_L34P	A9
1	IO_L35N_YY	C9
1	IO_VREF_L35P_YY	D10 ¹
1	IO_L36N_YY	A8
1	IO_L36P_YY	B8
1	IO_L37N_Y	E10
1	IO_L37P_Y	C8
1	IO_L38N_YY	B7
1	IO_VREF_L38P_YY	A6
1	IO_L39N_YY	C7
1	IO_L39P_YY	D8
1	IO_L40N	A5
1	IO_L40P	B5
1	IO_L41N_YY	C6
1	IO_VREF_L41P_YY	D7
1	IO_L42N_YY	A4
1	IO_L42P_YY	B4
1	IO_L43N_Y	C5
1	IO_L43P_Y	E7
1	IO_WRITE_L44N_YY	D6
1	IO_CS_L44P_YY	A2

Table 1: BG560 BGA — XCV405E and XCV812E

Bank	Pin Description	Pin#
2	IO	D3
2	IO	F3
2	IO	G1
2	IO	J2
2	IO_DOUT_BUSY_L45P_YY	D4
2	IO_DIN_D0_L45N_YY	E4
2	IO_L46P_Y	F5
2	IO_L46N_Y	B3
2	IO_L47P	F4
2	IO_L47N	C1
2	IO_VREF_L48P_Y	G5
2	IO_L48N_Y	E3
2	IO_L49P_Y	D2
2	IO_L49N_Y	G4
2	IO_L50P_Y	H5
2	IO_L50N_Y	E2
2	IO_VREF_L51P_YY	H4
2	IO_L51N_YY	G3
2	IO_L52P_Y	J5
2	IO_L52N_Y	F1
2	IO_L53P	J4
2	IO_L53N	H3
2	IO_VREF_L54P_YY	K5 ¹
2	IO_L54N_YY	H2
2	IO_L55P_Y	J3
2	IO_L55N_Y	K4
2	IO_VREF_L56P_YY	L5
2	IO_D1_L56N_YY	K3
2	IO_D2_L57P_YY	L4
2	IO_L57N_YY	K2
2	IO_L58P_Y	M5
2	IO_L58N_Y	L3
2	IO_L59P	L1
2	IO_L59N	M4
2	IO_VREF_L60P_Y	N5 ¹
2	IO_L60N_Y	M2
2	IO_L61P_Y	N4

Table 1: BG560 BGA — XCV405E and XCV812E

Bank	Pin Description	Pin#
2	IO_L61N_Y	N3
2	IO_L62P_Y	N2
2	IO_L62N_Y	P5
2	IO_VREF_L63P_YY	P4
2	IO_D3_L63N_YY	P3
2	IO_L64P_Y	P2
2	IO_L64N_Y	R5
2	IO_L65P_Y	R4
2	IO_L65N_Y	R3
2	IO_VREF_L66P_Y	R1
2	IO_L66N_Y	T4
2	IO_L67P_Y	T5
2	IO_L67N_Y	T3
2	IO_L68P_YY	T2
2	IO_L68N_YY	U3
3	IO	U4
3	IO	AE3
3	IO	AF3
3	IO	AH3
3	IO	AK3
3	IO_L69P_Y	U1
3	IO_L69N_Y	U2
3	IO_L70P_Y	V2
3	IO_VREF_L70N_Y	V4
3	IO_L71P_Y	V5
3	IO_L71N_Y	V3
3	IO_L72P	W1
3	IO_L72N	W3
3	IO_D4_L73P_YY	W4
3	IO_VREF_L73N_YY	W5
3	IO_L74P_Y	Y3
3	IO_L74N_Y	Y4
3	IO_L75P	AA1
3	IO_L75N	Y5
3	IO_L76P_Y	AA3
3	IO_VREF_L76N_Y	AA4 ¹

Table 1: BG560 BGA — XCV405E and XCV812E

Bank	Pin Description	Pin#
3	IO_L77P	AB3
3	IO_L77N	AA5
3	IO_L78P	AC1
3	IO_L78N	AB4
3	IO_L79P_YY	AC3
3	IO_D5_L79N_YY	AB5
3	IO_D6_L80P_YY	AC4
3	IO_VREF_L80N_YY	AD3
3	IO_L81P_Y	AE1
3	IO_L81N_Y	AC5
3	IO_L82P_YY	AD4
3	IO_VREF_L82N_YY	AF1 ¹
3	IO_L83P_Y	AF2
3	IO_L83N_Y	AD5
3	IO_L84P_Y	AG2
3	IO_L84N_Y	AE4
3	IO_L85P_YY	AH1
3	IO_VREF_L85N_YY	AE5
3	IO_L86P_Y	AF4
3	IO_L86N_Y	AJ1
3	IO_L87P_Y	AJ2
3	IO_L87N_Y	AF5
3	IO_L88P_Y	AG4
3	IO_VREF_L88N_Y	AK2
3	IO_L89P_Y	AJ3
3	IO_L89N_Y	AG5
3	IO_L90P_Y	AL1
3	IO_L90N_Y	AH4
3	IO_D7_L91P_YY	AJ4
3	IO_INIT_L91N_YY	AH5
4	GCK0	AL17
4	IO	AJ8
4	IO	AJ11
4	IO	AK6
4	IO	AK9
4	IO_L92P_YY	AL4

Table 1: BG560 BGA — XCV405E and XCV812E

Bank	Pin Description	Pin#
4	IO_L92N_YY	AJ6
4	IO_L93P	AK5
4	IO_L93N	AN3
4	IO_L94P_YY	AL5
4	IO_L94N_YY	AJ7
4	IO_VREF_L95P_YY	AM4
4	IO_L95N_YY	AM5
4	IO_L96P_Y	AK7
4	IO_L96N_Y	AL6
4	IO_L97P_YY	AM6
4	IO_L97N_YY	AN6
4	IO_VREF_L98P_YY	AL7
4	IO_L98N_YY	AJ9
4	IO_L99P	AN7
4	IO_L99N	AL8
4	IO_L100P_YY	AM8
4	IO_L100N_YY	AJ10
4	IO_VREF_L101P_YY	AL9 ¹
4	IO_L101N_YY	AM9
4	IO_L102P_Y	AK10
4	IO_L102N_Y	AN9
4	IO_VREF_L103P_YY	AL10
4	IO_L103N_YY	AM10
4	IO_L104P_YY	AL11
4	IO_L104N_YY	AJ12
4	IO_L105P	AN11
4	IO_L105N	AK12
4	IO_L106P_YY	AL12
4	IO_L106N_YY	AM12
4	IO_VREF_L107P_YY	AK13 ¹
4	IO_L107N_YY	AL13
4	IO_L108P_Y	AM13
4	IO_L108N_Y	AN13
4	IO_L109P_YY	AJ14
4	IO_L109N_YY	AK14
4	IO_VREF_L110P_YY	AM14
4	IO_L110N_YY	AN15

Table 1: BG560 BGA — XCV405E and XCV812E

Bank	Pin Description	Pin#
4	IO_L111P	AJ15
4	IO_L111N	AK15
4	IO_L112P_YY	AL15
4	IO_L112N_YY	AM16
4	IO_VREF_L113P_YY	AL16
4	IO_L113N_YY	AJ16
4	IO_L114P_Y	AK16
4	IO_L114N_Y	AN17
4	IO_LVDS_DLL_L115P	AM17
5	GCK1	AJ17
5	IO	AL18
5	IO	AL25
5	IO	AL28
5	IO	AL30
5	IO	AN28
5	IO_LVDS_DLL_L115N	AM18
5	IO_L116P_YY	AK18
5	IO_VREF_L116N_YY	AJ18
5	IO_L117P_YY	AN19
5	IO_L117N_YY	AL19
5	IO_L118P	AK19
5	IO_L118N	AM20
5	IO_L119P_YY	AJ19
5	IO_VREF_L119N_YY	AL20
5	IO_L120P_YY	AN21
5	IO_L120N_YY	AL21
5	IO_L121P_Y	AJ20
5	IO_L121N_Y	AM22
5	IO_L122P_YY	AK21
5	IO_VREF_L122N_YY	AN23 ¹
5	IO_L123P_YY	AJ21
5	IO_L123N_YY	AM23
5	IO_L124P	AK22
5	IO_L124N	AM24
5	IO_L125P_YY	AL23
5	IO_L125N_YY	AJ22

Table 1: BG560 BGA — XCV405E and XCV812E

Bank	Pin Description	Pin#
5	IO_L126P_YY	AK23
5	IO_VREF_L126N_YY	AL24
5	IO_L127P_Y	AN26
5	IO_L127N_Y	AJ23
5	IO_L128P_YY	AK24
5	IO_VREF_L128N_YY	AM26 ¹
5	IO_L129P_YY	AM27
5	IO_L129N_YY	AJ24
5	IO_L130P_Y	AL26
5	IO_L130N_Y	AK25
5	IO_L131P_YY	AN29
5	IO_VREF_L131N_YY	AJ25
5	IO_L132P_YY	AK26
5	IO_L132N_YY	AM29
5	IO_L133P_Y	AM30
5	IO_L133N_Y	AJ26
5	IO_L134P_YY	AK27
5	IO_VREF_L134N_YY	AL29
5	IO_L135P_YY	AN31
5	IO_L135N_YY	AJ27
5	IO_L136P_Y	AM31
5	IO_L136N_Y	AK28
6	IO	U29
6	IO	AE33
6	IO	AF31
6	IO	AJ32
6	IO	AL33
6	IO_L137N_YY	AH29
6	IO_L137P_YY	AJ30
6	IO_L138N_Y	AK31
6	IO_L138P_Y	AH30
6	IO_L139N_Y	AG29
6	IO_L139P_Y	AJ31
6	IO_VREF_L140N_Y	AK32
6	IO_L140P_Y	AG30
6	IO_L141N_Y	AH31

Table 1: BG560 BGA — XCV405E and XCV812E

Bank	Pin Description	Pin#
6	IO_L141P_Y	AF29
6	IO_L142N_Y	AH32
6	IO_L142P_Y	AF30
6	IO_VREF_L143N_YY	AE29
6	IO_L143P_YY	AH33
6	IO_L144N_Y	AG33
6	IO_L144P_Y	AE30
6	IO_L145N_Y	AD29
6	IO_L145P_Y	AF32
6	IO_VREF_L146N_Y	AE31 ¹
6	IO_L146P_Y	AD30
6	IO_L147N_Y	AE32
6	IO_L147P_Y	AC29
6	IO_VREF_L148N_YY	AD31
6	IO_L148P_YY	AC30
6	IO_L149N_YY	AB29
6	IO_L149P_YY	AC31
6	IO_L150N_Y	AC33
6	IO_L150P_Y	AB30
6	IO_L151N_Y	AB31
6	IO_L151P_Y	AA29
6	IO_VREF_L152N_Y	AA30 ¹
6	IO_L152P_Y	AA31
6	IO_L153N_Y	AA32
6	IO_L153P_Y	Y29
6	IO_L154N_Y	AA33
6	IO_L154P_Y	Y30
6	IO_VREF_L155N_YY	Y32
6	IO_L155P_YY	W29
6	IO_L156N_Y	W30
6	IO_L156P_Y	W31
6	IO_L157N_Y	W33
6	IO_L157P_Y	V30
6	IO_VREF_L158N_Y	V29
6	IO_L158P_Y	V31
6	IO_L159N_Y	V32
6	IO_L159P_Y	U33

Table 1: BG560 BGA — XCV405E and XCV812E

Bank	Pin Description	Pin#
7	IO	E30
7	IO	F29
7	IO	F33
7	IO	G30
7	IO	K30
7	IO_L160N_YY	U31
7	IO_L160P_YY	U32
7	IO_L161N_Y	T32
7	IO_L161P_Y	T30
7	IO_L162N_Y	T29
7	IO_VREF_L162P_Y	T31
7	IO_L163N_Y	R33
7	IO_L163P_Y	R31
7	IO_L164N_Y	R30
7	IO_L164P_Y	R29
7	IO_L165N_YY	P32
7	IO_VREF_L165P_YY	P31
7	IO_L166N_Y	P30
7	IO_L166P_Y	P29
7	IO_L167N_Y	M32
7	IO_L167P_Y	N31
7	IO_L168N_Y	N30
7	IO_VREF_L168P_Y	L33 ¹
7	IO_L169N_Y	M31
7	IO_L169P_Y	L32
7	IO_L170N_Y	M30
7	IO_L170P_Y	L31
7	IO_L171N_YY	M29
7	IO_L171P_YY	J33
7	IO_L172N_YY	L30
7	IO_VREF_L172P_YY	K31
7	IO_L173N_Y	L29
7	IO_L173P_Y	H33
7	IO_L174N_Y	J31
7	IO_VREF_L174P_Y	H32 ¹
7	IO_L175N_Y	K29

Table 1: BG560 BGA — XCV405E and XCV812E

Bank	Pin Description	Pin#
7	IO_L175P_Y	H31
7	IO_L176N_Y	J30
7	IO_L176P_Y	G32
7	IO_L177N_YY	J29
7	IO_VREF_L177P_YY	G31
7	IO_L178N_Y	E33
7	IO_L178P_Y	E32
7	IO_L179N_Y	H29
7	IO_L179P_Y	F31
7	IO_L180N_Y	D32
7	IO_VREF_L180P_Y	E31
7	IO_L181N_Y	G29
7	IO_L181P_Y	C33
7	IO_L182N_Y	F30
7	IO_L182P_Y	D31
2	CCLK	C4
3	DONE	AJ5
NA	DXN	AK29
NA	DXP	AJ28
NA	M0	AJ29
NA	M1	AK30
NA	M2	AN32
NA	PROGRAM	AM1
NA	TCK	E29
NA	TDI	D5
2	TDO	E6
NA	TMS	B33
NA	NC	C31
NA	NC	AC2
NA	NC	AK4
NA	NC	AL3
NA	VCCINT	A21
NA	VCCINT	B12
NA	VCCINT	B14

Table 1: BG560 BGA — XCV405E and XCV812E

Bank	Pin Description	Pin#
NA	VCCINT	B18
NA	VCCINT	B28
NA	VCCINT	C22
NA	VCCINT	C24
NA	VCCINT	E9
NA	VCCINT	E12
NA	VCCINT	F2
NA	VCCINT	H30
NA	VCCINT	J1
NA	VCCINT	K32
NA	VCCINT	M3
NA	VCCINT	N1
NA	VCCINT	N29
NA	VCCINT	N33
NA	VCCINT	U5
NA	VCCINT	U30
NA	VCCINT	Y2
NA	VCCINT	Y31
NA	VCCINT	AB2
NA	VCCINT	AB32
NA	VCCINT	AD2
NA	VCCINT	AD32
NA	VCCINT	AG3
NA	VCCINT	AG31
NA	VCCINT	AJ13
NA	VCCINT	AK8
NA	VCCINT	AK11
NA	VCCINT	AK17
NA	VCCINT	AK20
NA	VCCINT	AL14
NA	VCCINT	AL22
NA	VCCINT	AL27
NA	VCCINT	AN25
0	VCCO	A22
0	VCCO	A26
0	VCCO	A30

Table 1: BG560 BGA — XCV405E and XCV812E

Bank	Pin Description	Pin#
0	VCCO	B19
0	VCCO	B32
1	VCCO	A10
1	VCCO	A16
1	VCCO	B13
1	VCCO	C3
1	VCCO	E5
2	VCCO	B2
2	VCCO	D1
2	VCCO	H1
2	VCCO	M1
2	VCCO	R2
3	VCCO	V1
3	VCCO	AA2
3	VCCO	AD1
3	VCCO	AK1
3	VCCO	AL2
4	VCCO	AN4
4	VCCO	AN8
4	VCCO	AN12
4	VCCO	AM2
4	VCCO	AM15
5	VCCO	AL31
5	VCCO	AM21
5	VCCO	AN18
5	VCCO	AN24
5	VCCO	AN30
6	VCCO	W32
6	VCCO	AB33
6	VCCO	AF33
6	VCCO	AK33
6	VCCO	AM32
7	VCCO	C32
7	VCCO	D33
7	VCCO	K33
7	VCCO	N32
7	VCCO	T33

Table 1: BG560 BGA — XCV405E and XCV812E

Bank	Pin Description	Pin#
NA	GND	A1
NA	GND	A7
NA	GND	A12
NA	GND	A14
NA	GND	A18
NA	GND	A20
NA	GND	A24
NA	GND	A29
NA	GND	A32
NA	GND	A33
NA	GND	B1
NA	GND	B6
NA	GND	B9
NA	GND	B15
NA	GND	B23
NA	GND	B27
NA	GND	B31
NA	GND	C2
NA	GND	E1
NA	GND	F32
NA	GND	G2
NA	GND	G33
NA	GND	J32
NA	GND	K1
NA	GND	L2
NA	GND	M33
NA	GND	P1
NA	GND	P33
NA	GND	R32
NA	GND	T1
NA	GND	V33
NA	GND	W2
NA	GND	Y1
NA	GND	Y33
NA	GND	AB1
NA	GND	AC32

Table 1: BG560 BGA — XCV405E and XCV812E

Bank	Pin Description	Pin#
NA	GND	AD33
NA	GND	AE2
NA	GND	AG1
NA	GND	AG32
NA	GND	AH2
NA	GND	AJ33
NA	GND	AL32
NA	GND	AM3
NA	GND	AM7
NA	GND	AM11
NA	GND	AM19
NA	GND	AM25
NA	GND	AM28
NA	GND	AM33
NA	GND	AN1
NA	GND	AN2
NA	GND	AN5
NA	GND	AN10
NA	GND	AN14
NA	GND	AN16
NA	GND	AN20
NA	GND	AN22
NA	GND	AN27
NA	GND	AN33

Notes:

1. V_{REF} or I/O option only in the XCV812E.

BG560 Differential Pin Pairs

Virtex-E Extended Memory devices have differential pin pairs that can also provide other functions when not used as a differential pair. A √ in the AO column indicates that the pin pair can be used as an asynchronous output for all devices provided in this package.

Pairs with a note number in the AO column are device dependent. They can have asynchronous outputs if the pin pair is in the same CLB row and column in the device. Numbers in this column refer to footnotes that indicate which devices have pin pairs that can be asynchronous outputs. The Other Functions column indicates alternative function(s) not available when the pair is used as a differential pair or differential clock.

Table 2: BG560 Package Differential Pin Pair Summary XCV405E and XCV812E

Pair	Bank	P Pin	N Pin	AO	Other Functions
Global Differential Clock					
3	0	A17	C18	NA	IO LVDS 21
2	1	D17	E17	NA	IO LVDS 21
1	5	AJ17	AM18	NA	IO LVDS 115
0	4	AL17	AM17	NA	IO LVDS 115
IO LVDS Total Outputs: 183, Asynchronous Outputs: 79					
0	0	D29	E28	NA	-
1	0	A31	D28	√	-
2	0	C29	E27	√	VREF_0
3	0	D27	B30	1	-
4	0	B29	E26	√	-
5	0	C27	D26	√	VREF_0
6	0	A28	E25	NA	-
7	0	C26	D25	1	-
8	0	B26	E24	1	VREF_0
9	0	D24	C25	1	-
10	0	A25	E23	√	VREF_0
11	0	B24	D23	√	-
12	0	C23	E22	NA	-
13	0	D22	A23	√	-
14	0	B22	E21	√	VREF_0
15	0	C21	D21	1	-

Table 2: BG560 Package Differential Pin Pair Summary XCV405E and XCV812E

16	0	E20	B21	√	-
17	0	C20	D20	√	VREF_0
18	0	E19	B20	NA	-
19	0	C19	D19	1	-
20	0	D18	A19	1	VREF_0
21	1	E17	C18	NA	GCLK LVDS 3/2
22	1	B17	C17	1	-
23	1	D16	B16	1	VREF_1
24	1	C16	E16	1	-
25	1	C15	A15	NA	-
26	1	E15	D15	√	VREF_1
27	1	D14	C14	√	-
28	1	E14	A13	1	-
29	1	D13	C13	√	VREF_1
30	1	E13	C12	√	-
31	1	D12	A11	NA	-
32	1	C11	B11	√	-
33	1	D11	B10	√	VREF_1
34	1	A9	C10	2	-
35	1	D10	C9	1	VREF_1
36	1	B8	A8	1	-
37	1	C8	E10	NA	-
38	1	A6	B7	√	VREF_1
39	1	D8	C7	√	-
40	1	B5	A5	2	-
41	1	D7	C6	√	VREF_1
42	1	B4	A4	√	-
43	1	E7	C5	NA	-
44	1	A2	D6	√	CS
45	2	D4	E4	√	DIN_D0
46	2	F5	B3	2	-
47	2	F4	C1	NA	-
48	2	G5	E3	1	VREF_2
49	2	D2	G4	1	-

Table 2: BG560 Package Differential Pin Pair Summary XCV405E and XCV812E

50	2	H5	E2	NA	-
51	2	H4	G3	√	VREF_2
52	2	J5	F1	NA	-
53	2	J4	H3	2	-
54	2	K5	H2	NA	VREF_2
55	2	J3	K4	NA	-
56	2	L5	K3	√	D1
57	2	L4	K2	√	D2
58	2	M5	L3	2	-
59	2	L1	M4	NA	-
60	2	N5	M2	1	VREF_2
61	2	N4	N3	1	-
62	2	N2	P5	NA	-
63	2	P4	P3	√	D3
64	2	P2	R5	2	-
65	2	R4	R3	NA	-
66	2	R1	T4	NA	VREF_2
67	2	T5	T3	NA	-
68	2	T2	U3	√	IRDY
69	3	U1	U2	NA	-
70	3	V2	V4	NA	VREF_3
71	3	V5	V3	NA	-
72	3	W1	W3	2	-
73	3	W4	W5	√	VREF_3
74	3	Y3	Y4	NA	-
75	3	AA1	Y5	1	-
76	3	AA3	AA4	1	VREF_3
77	3	AB3	AA5	NA	-
78	3	AC1	AB4	2	-
79	3	AC3	AB5	√	D5
80	3	AC4	AD3	√	VREF_3
81	3	AE1	AC5	1	-
82	3	AD4	AF1	NA	VREF_3
83	3	AF2	AD5	NA	-

Table 2: BG560 Package Differential Pin Pair Summary XCV405E and XCV812E

84	3	AG2	AE4	NA	-
85	3	AH1	AE5	√	VREF_3
86	3	AF4	AJ1	NA	-
87	3	AJ2	AF5	2	-
88	3	AG4	AK2	1	VREF_3
89	3	AJ3	AG5	NA	-
90	3	AL1	AH4	NA	-
91	3	AJ4	AH5	√	INIT
92	4	AL4	AJ6	√	-
93	4	AK5	AN3	NA	-
94	4	AL5	AJ7	√	-
95	4	AM4	AM5	√	VREF_4
96	4	AK7	AL6	1	-
97	4	AM6	AN6	√	-
98	4	AL7	AJ9	√	VREF_4
99	4	AN7	AL8	NA	-
100	4	AM8	AJ10	1	-
101	4	AL9	AM9	1	VREF_4
102	4	AK10	AN9	1	-
103	4	AL10	AM10	√	VREF_4
104	4	AL11	AJ12	√	-
105	4	AN11	AK12	NA	-
106	4	AL12	AM12	√	-
107	4	AK13	AL13	√	VREF_4
108	4	AM13	AN13	1	-
109	4	AJ14	AK14	√	-
110	4	AM14	AN15	√	VREF_4
111	4	AJ15	AK15	NA	-
112	4	AL15	AM16	1	-
113	4	AL16	AJ16	1	VREF_4
114	4	AK16	AN17	1	-
115	5	AM17	AM18	NA	GCLK LVDS 1/0
116	5	AK18	AJ18	1	VREF_5
117	5	AN19	AL19	1	-

Table 2: BG560 Package Differential Pin Pair Summary XCV405E and XCV812E

118	5	AK19	AM20	NA	-
119	5	AJ19	AL20	√	VREF_5
120	5	AN21	AL21	√	-
121	5	AJ20	AM22	1	-
122	5	AK21	AN23	√	VREF_5
123	5	AJ21	AM23	√	-
124	5	AK22	AM24	NA	-
125	5	AL23	AJ22	√	-
126	5	AK23	AL24	√	VREF_5
127	5	AN26	AJ23	2	-
128	5	AK24	AM26	1	VREF_5
129	5	AM27	AJ24	1	-
130	5	AL26	AK25	NA	-
131	5	AN29	AJ25	√	VREF_5
132	5	AK26	AM29	√	-
133	5	AM30	AJ26	2	-
134	5	AK27	AL29	√	VREF_5
135	5	AN31	AJ27	√	-
136	5	AM31	AK28	NA	-
137	6	AJ30	AH29	√	-
138	6	AH30	AK31	2	-
139	6	AJ31	AG29	NA	-
140	6	AG30	AK32	1	VREF_6
141	6	AF29	AH31	1	-
142	6	AF30	AH32	NA	-
143	6	AH33	AE29	√	VREF_6
144	6	AE30	AG33	2	-
145	6	AF32	AD29	NA	-
146	6	AD30	AE31	NA	VREF_6
147	6	AC29	AE32	NA	-
148	6	AC30	AD31	√	VREF_6
149	6	AC31	AB29	√	-
150	6	AB30	AC33	2	-
151	6	AA29	AB31	NA	-

Table 2: BG560 Package Differential Pin Pair Summary XCV405E and XCV812E

152	6	AA31	AA30	1	VREF_6
153	6	Y29	AA32	1	-
154	6	Y30	AA33	NA	-
155	6	W29	Y32	√	VREF_6
156	6	W31	W30	2	-
157	6	V30	W33	NA	-
158	6	V31	V29	NA	VREF_6
159	6	U33	V32	NA	-
160	7	U32	U31	√	IRDY
161	7	T30	T32	NA	-
162	7	T31	T29	NA	VREF_7
163	7	R31	R33	NA	-
164	7	R29	R30	2	-
165	7	P31	P32	√	VREF_7
166	7	P29	P30	NA	-
167	7	N31	M32	1	-
168	7	L33	N30	1	VREF_7
169	7	L32	M31	NA	-
170	7	L31	M30	2	-
171	7	J33	M29	√	-
172	7	K31	L30	√	VREF_7
173	7	H33	L29	1	-
174	7	H32	J31	NA	VREF_7
175	7	H31	K29	NA	-
176	7	G32	J30	NA	-
177	7	G31	J29	√	VREF_7
178	7	E32	E33	NA	-
179	7	F31	H29	2	-
180	7	E31	D32	1	VREF_7
181	7	C33	G29	NA	-
182	7	D31	F30	NA	-

Notes:

1. AO in the XCV812E
2. AO in the XCV405E

FG676 Fine-Pitch Ball Grid Array Package

XCV405E Virtex-E Extended Memory devices are available in the FG676 fine-pitch BGA package. Pins labeled IO_VREF can be used as either. If the pin is not used as V_{REF} it can be used as general I/O. Immediately following Table 3, see Table 4 for FG676 package Differential Pair information.

Table 3: FG676 Fine-Pitch BGA — XCV405E

Bank	Pin Description	Pin #
0	GCK3	E13
0	IO	A6
0	IO	B3
0	IO	C6
0	IO	C8
0	IO	D5
0	IO	G13
0	IO_L0N_Y	C4
0	IO_L0P_Y	F7
0	IO_L1N_YY	G8
0	IO_L1P_YY	C5
0	IO_VREF_L2N_YY	D6
0	IO_L2P_YY	E7
0	IO_L3N	A4
0	IO_L3P	F8
0	IO_L4N	B5
0	IO_L4P	D7
0	IO_VREF_L5N_YY	E8
0	IO_L5P_YY	G9
0	IO_L6N_YY	A5
0	IO_L6P_YY	F9
0	IO_L7N_Y	D8
0	IO_L7P_Y	C7
0	IO_L8N_Y	B7
0	IO_L8P_Y	E9
0	IO_L9N	A7
0	IO_L9P	D9
0	IO_L10N	B8
0	IO_VREF_L10P	G10

Table 3: FG676 Fine-Pitch BGA — XCV405E

Bank	Pin Description	Pin #
0	IO_L11N_YY	C9
0	IO_L11P_YY	F10
0	IO_L12N_Y	A8
0	IO_L12P_Y	E10
0	IO_L13N_YY	G11
0	IO_L13P_YY	D10
0	IO_L14N_YY	B10
0	IO_L14P_YY	F11
0	IO_L15N	C10
0	IO_L15P	E11
0	IO_L16N_YY	G12
0	IO_L16P_YY	D11
0	IO_VREF_L17N_YY	C11
0	IO_L17P_YY	F12
0	IO_L18N_YY	A11
0	IO_L18P_YY	E12
0	IO_L19N_Y	D12
0	IO_L19P_Y	C12
0	IO_VREF_L20N_Y	A12
0	IO_L20P_Y	H13
0	IO_LVDS_DLL_L21N	B13
1	GCK2	C13
1	IO	A19
1	IO	A20
1	IO	A22
1	IO	B23
1	IO_LVDS_DLL_L21P	F14
1	IO_L22N	E14
1	IO_L22P	F13
1	IO_L23N_Y	D14
1	IO_VREF_L23P_Y	A14
1	IO_L24N_Y	C14
1	IO_L24P_Y	H14
1	IO_L25N_YY	G14

Table 3: FG676 Fine-Pitch BGA — XCV405E

Bank	Pin Description	Pin #
1	IO_L25P_YY	C15
1	IO_L26N_YY	E15
1	IO_VREF_L26P_YY	D15
1	IO_L27N_YY	C16
1	IO_L27P_YY	F15
1	IO_L28N	G15
1	IO_L28P	D16
1	IO_L29N_YY	E16
1	IO_L29P_YY	A17
1	IO_L30N_YY	C17
1	IO_L30P_YY	E17
1	IO_L31N_Y	F16
1	IO_L31P_Y	D17
1	IO_L32N_YY	F17
1	IO_L32P_YY	C18
1	IO_L33N_YY	A18
1	IO_VREF_L33P_YY	G16
1	IO_L34N_YY	C19
1	IO_L34P_YY	G17
1	IO_L35N_Y	D18
1	IO_L35P_Y	B19
1	IO_L36N_Y	D19
1	IO_L36P_Y	E18
1	IO_L37N_YY	F18
1	IO_L37P_YY	B20
1	IO_L38N_YY	G19
1	IO_VREF_L38P_YY	C20
1	IO_L39N_YY	G18
1	IO_L39P_YY	E19
1	IO_L40N_YY	A21
1	IO_L40P_YY	D20
1	IO_L41N_YY	F19
1	IO_VREF_L41P_YY	C21
1	IO_L42N_YY	B22
1	IO_L42P_YY	E20

Table 3: FG676 Fine-Pitch BGA — XCV405E

Bank	Pin Description	Pin #
1	IO_L43N_Y	A23
1	IO_L43P_Y	D21
1	IO_WRITE_L44N_YY	C22
1	IO_CS_L44P_YY	E21
2	IO	D26
2	IO	E26
2	IO	F26
2	IO_D1	K24
2	IO_DOUT_BUSY_L45P_YY	E23
2	IO_DIN_D0_L45N_YY	F22
2	IO_L46P_YY	E24
2	IO_L46N_YY	F20
2	IO_L47P_Y	G21
2	IO_L47N_Y	G22
2	IO_VREF_L48P_Y	F24
2	IO_L48N_Y	H20
2	IO_L49P_Y	E25
2	IO_L49N_Y	H21
2	IO_L50P_YY	F23
2	IO_L50N_YY	G23
2	IO_VREF_L51P_YY	H23
2	IO_L51N_YY	J20
2	IO_L52P_YY	G24
2	IO_L52N_YY	H22
2	IO_L53P_Y	J21
2	IO_L53N_Y	G25
2	IO_L54P_Y	G26
2	IO_L54N_Y	J22
2	IO_L55P_YY	H24
2	IO_L55N_YY	J23
2	IO_L56P_YY	J24
2	IO_VREF_L56N_YY	K20
2	IO_D2_L57P_YY	K22
2	IO_L57N_YY	K21

Table 3: FG676 Fine-Pitch BGA — XCV405E

Bank	Pin Description	Pin #
2	IO_L58P_YY	H25
2	IO_L58N_YY	K23
2	IO_L59P_Y	L20
2	IO_L59N_Y	J26
2	IO_L60P_Y	K25
2	IO_L60N_Y	L22
2	IO_L61P_Y	L21
2	IO_L61N_Y	L23
2	IO_L62P_Y	M20
2	IO_L62N_Y	L24
2	IO_VREF_L63P_YY	M23
2	IO_D3_L63N_YY	M22
2	IO_L64P_YY	L26
2	IO_L64N_YY	M21
2	IO_L65P_Y	N19
2	IO_L65N_Y	M24
2	IO_VREF_L66P_Y	M26
2	IO_L66N_Y	N20
2	IO_L67P_YY	N24
2	IO_L67N_YY	N21
2	IO_L68P_YY	N23
2	IO_L68N_YY	N22
3	IO	P24
3	IO	W25
3	IO	Y26
3	IO	AB25
3	IO	AC26
3	IO_L69P_YY	P21
3	IO_L69N_YY	P23
3	IO_L70P_Y	P22
3	IO_VREF_L70N_Y	R25
3	IO_L71P_Y	P19
3	IO_L71N_Y	P20
3	IO_L72P_YY	R21

Table 3: FG676 Fine-Pitch BGA — XCV405E

Bank	Pin Description	Pin #
3	IO_L72N_YY	R22
3	IO_D4_L73P_YY	R24
3	IO_VREF_L73N_YY	R23
3	IO_L74P_Y	T24
3	IO_L74N_Y	R20
3	IO_L75P_Y	T22
3	IO_L75N_Y	U24
3	IO_L76P_Y	T23
3	IO_L76N_Y	U25
3	IO_L77P_Y	T21
3	IO_L77N_Y	U20
3	IO_L78P_YY	U22
3	IO_L78N_YY	V26
3	IO_L79P_YY	T20
3	IO_D5_L79N_YY	U23
3	IO_D6_L80P_YY	V24
3	IO_VREF_L80N_YY	U21
3	IO_L81P_YY	V23
3	IO_L81N_YY	W24
3	IO_L82P_Y	V22
3	IO_L82N_Y	W26
3	IO_L83P_Y	Y25
3	IO_L83N_Y	V21
3	IO_L84P_YY	V20
3	IO_L84N_YY	AA26
3	IO_L85P_YY	Y24
3	IO_VREF_L85N_YY	W23
3	IO_L86P_Y	AA24
3	IO_L86N_Y	Y23
3	IO_L87P_Y	AB26
3	IO_L87N_Y	W21
3	IO_L88P_Y	Y22
3	IO_VREF_L88N_Y	W22
3	IO_L89P_Y	AA23
3	IO_L89N_Y	AB24

Table 3: FG676 Fine-Pitch BGA — XCV405E

Bank	Pin Description	Pin #
3	IO_L90P_YY	W20
3	IO_L90N_YY	AC24
3	IO_D7_L91P_YY	AB23
3	IO_INIT_L91N_YY	Y21
4	GCK0	AA14
4	IO	AC18
4	IO	AE20
4	IO	AE23
4	IO	AF21
4	IO_L92P_YY	AC22
4	IO_L92N_YY	AD26
4	IO_L93P_Y	AD23
4	IO_L93N_Y	AA20
4	IO_L94P_YY	Y19
4	IO_L94N_YY	AC21
4	IO_VREF_L95P_YY	AD22
4	IO_L95N_YY	AB20
4	IO_L96P	AE22
4	IO_L96N	Y18
4	IO_L97P	AF22
4	IO_L97N	AA19
4	IO_VREF_L98P_YY	AD21
4	IO_L98N_YY	AB19
4	IO_L99P_YY	AC20
4	IO_L99N_YY	AA18
4	IO_L100P_Y	AC19
4	IO_L100N_Y	AD20
4	IO_L101P_Y	AF20
4	IO_L101N_Y	AB18
4	IO_L102P	AD19
4	IO_L102N	Y17
4	IO_L103P	AE19
4	IO_VREF_L103N	AD18
4	IO_L104P_YY	AF19

Table 3: FG676 Fine-Pitch BGA — XCV405E

Bank	Pin Description	Pin #
4	IO_L104N_YY	AA17
4	IO_L105P_Y	AC17
4	IO_L105N_Y	AB17
4	IO_L106P_YY	Y16
4	IO_L106N_YY	AE17
4	IO_L107P_YY	AF17
4	IO_L107N_YY	AA16
4	IO_L108P	AD17
4	IO_L108N	AB16
4	IO_L109P_YY	AC16
4	IO_L109N_YY	AD16
4	IO_VREF_L110P_YY	AC15
4	IO_L110N_YY	Y15
4	IO_L111P_YY	AD15
4	IO_L111N_YY	AA15
4	IO_L112P_Y	W14
4	IO_L112N_Y	AB15
4	IO_VREF_L113P_Y	AF15
4	IO_L113N_Y	Y14
4	IO_L114P	AD14
4	IO_L114N	AB14
4	IO_LVDS_DLL_L115P	AC14
5	GCK1	AB13
5	IO	AD7
5	IO	AD13
5	IO	AE4
5	IO	AE7
5	IO	AF5
5	IO_LVDS_DLL_L115N	AF13
5	IO_L116P_Y	AA13
5	IO_VREF_L116N_Y	AF12
5	IO_L117P_Y	AC13
5	IO_L117N_Y	W13
5	IO_L118P_YY	AA12

Table 3: FG676 Fine-Pitch BGA — XCV405E

Bank	Pin Description	Pin #
5	IO_L118N_YY	AD12
5	IO_L119P_YY	AC12
5	IO_VREF_L119N_YY	AB12
5	IO_L120P_YY	AD11
5	IO_L120N_YY	Y12
5	IO_L121P	AB11
5	IO_L121N	AD10
5	IO_L122P_YY	AC11
5	IO_L122N_YY	AE10
5	IO_L123P_YY	AC10
5	IO_L123N_YY	AA11
5	IO_L124P_Y	Y11
5	IO_L124N_Y	AD9
5	IO_L125P_YY	AB10
5	IO_L125N_YY	AF9
5	IO_L126P_YY	AD8
5	IO_VREF_L126N_YY	AA10
5	IO_L127P_YY	AE8
5	IO_L127N_YY	Y10
5	IO_L128P_Y	AC9
5	IO_L128N_Y	AF8
5	IO_L129P_Y	AF7
5	IO_L129N_Y	AB9
5	IO_L130P_YY	AA9
5	IO_L130N_YY	AF6
5	IO_L131P_YY	AC8
5	IO_VREF_L131N_YY	AC7
5	IO_L132P_YY	AD6
5	IO_L132N_YY	Y9
5	IO_L133P_YY	AE5
5	IO_L133N_YY	AA8
5	IO_L134P_YY	AC6
5	IO_VREF_L134N_YY	AB8
5	IO_L135P_YY	AD5
5	IO_L135N_YY	AA7

Table 3: FG676 Fine-Pitch BGA — XCV405E

Bank	Pin Description	Pin #
5	IO_L136P_Y	AF4
5	IO_L136N_Y	AC5
6	IO	P3
6	IO	AA3
6	IO	W3
6	IO	Y2
6	IO	Y6
6	IO_L137N_YY	AA5
6	IO_L137P_YY	AC3
6	IO_L138N_YY	AC2
6	IO_L138P_YY	AB4
6	IO_L139N_Y	W6
6	IO_L139P_Y	AA4
6	IO_VREF_L140N_Y	AB3
6	IO_L140P_Y	Y5
6	IO_L141N_Y	AB2
6	IO_L141P_Y	V7
6	IO_L142N_YY	AB1
6	IO_L142P_YY	Y4
6	IO_VREF_L143N_YY	V5
6	IO_L143P_YY	W5
6	IO_L144N_YY	AA1
6	IO_L144P_YY	V6
6	IO_L145N_Y	W4
6	IO_L145P_Y	Y3
6	IO_L146N_Y	Y1
6	IO_L146P_Y	U7
6	IO_L147N_YY	W1
6	IO_L147P_YY	V4
6	IO_L148N_YY	W2
6	IO_VREF_L148P_YY	U6
6	IO_L149N_YY	V3
6	IO_L149P_YY	T5
6	IO_L150N_YY	U5

Table 3: FG676 Fine-Pitch BGA — XCV405E

Bank	Pin Description	Pin #
6	IO_L150P_YY	U4
6	IO_L151N_Y	T7
6	IO_L151P_Y	U3
6	IO_L152N_Y	U2
6	IO_L152P_Y	T6
6	IO_L153N_Y	U1
6	IO_L153P_Y	T4
6	IO_L154N_Y	R7
6	IO_L154P_Y	T3
6	IO_VREF_L155N_YY	R4
6	IO_L155P_YY	R6
6	IO_L156N_YY	R3
6	IO_L156P_YY	R5
6	IO_L157N_Y	P8
6	IO_L157P_Y	P7
6	IO_VREF_L158N_Y	R1
6	IO_L158P_Y	P6
6	IO_L159N_YY	P5
6	IO_L159P_YY	P4
7	IO	D2
7	IO	D3
7	IO	E1
7	IO	G1
7	IO	H2
7	IO_L160N_YY	N5
7	IO_L160P_YY	N8
7	IO_L161N_YY	N6
7	IO_L161P_YY	N3
7	IO_L162N_Y	N4
7	IO_VREF_L162P_Y	M2
7	IO_L163N_Y	N7
7	IO_L163P_Y	M7
7	IO_L164N_YY	M6
7	IO_L164P_YY	M3

Table 3: FG676 Fine-Pitch BGA — XCV405E

Bank	Pin Description	Pin #
7	IO_L165N_YY	M4
7	IO_VREF_L165P_YY	M5
7	IO_L166N_Y	L3
7	IO_L166P_Y	L7
7	IO_L167N_Y	L6
7	IO_L167P_Y	K2
7	IO_L168N_Y	L4
7	IO_L168P_Y	K1
7	IO_L169N_Y	K3
7	IO_L169P_Y	L5
7	IO_L170N_YY	K5
7	IO_L170P_YY	J3
7	IO_L171N_YY	K4
7	IO_L171P_YY	J4
7	IO_L172N_YY	H3
7	IO_VREF_L172P_YY	K6
7	IO_L173N_YY	K7
7	IO_L173P_YY	G3
7	IO_L174N_Y	J5
7	IO_L174P_Y	H1
7	IO_L175N_Y	G2
7	IO_L175P_Y	J6
7	IO_L176N_YY	J7
7	IO_L176P_YY	F1
7	IO_L177N_YY	H4
7	IO_VREF_L177P_YY	G4
7	IO_L178N_Y	F3
7	IO_L178P_Y	H5
7	IO_L179N_Y	E2
7	IO_L179P_Y	H6
7	IO_L180N_Y	G5
7	IO_VREF_L180P_Y	F4
7	IO_L181N_Y	H7
7	IO_L181P_Y	G6
7	IO_L182N_YY	E3

Table 3: FG676 Fine-Pitch BGA — XCV405E

Bank	Pin Description	Pin #
7	IO_L182P_YY	E4
2	CCLK	D24
3	DONE	AB21
NA	DXN	AB7
NA	DXP	Y8
NA	M0	AD4
NA	M1	W7
NA	M2	AB6
NA	PROGRAM	AA22
NA	TCK	E6
NA	TDI	D22
2	TDO	C23
NA	TMS	F5
0	NC	A9
0	NC	A10
0	NC	B4
0	NC	B12
0	NC	D13
1	NC	A13
1	NC	A16
1	NC	A24
1	NC	B15
1	NC	B17
2	NC	D25
2	NC	H26
2	NC	K26
2	NC	M25
2	NC	N26
3	NC	AC25
3	NC	P26
3	NC	R26
3	NC	T26
3	NC	U26

Table 3: FG676 Fine-Pitch BGA — XCV405E

Bank	Pin Description	Pin #
4	NC	AE15
4	NC	AF14
4	NC	AF16
4	NC	AF18
4	NC	AF23
5	NC	AE12
5	NC	AF3
5	NC	AF10
5	NC	AF11
5	NC	Y13
6	NC	AC1
6	NC	P1
6	NC	R2
6	NC	T1
6	NC	V1
7	NC	D1
7	NC	J1
7	NC	L1
7	NC	M1
7	NC	N1
NA	NC	T25
NA	NC	T2
NA	NC	P2
NA	NC	N25
NA	NC	L25
NA	NC	L2
NA	NC	F6
NA	NC	F25
NA	NC	F21
NA	NC	F2
NA	NC	C26
NA	NC	C25
NA	NC	C2
NA	NC	C1
NA	NC	B6

Table 3: FG676 Fine-Pitch BGA — XCV405E

Bank	Pin Description	Pin #
NA	NC	B26
NA	NC	B24
NA	NC	B21
NA	NC	B16
NA	NC	B11
NA	NC	B1
NA	NC	AF25
NA	NC	AF24
NA	NC	AF2
NA	NC	AE6
NA	NC	AE3
NA	NC	AE26
NA	NC	AE24
NA	NC	AE21
NA	NC	AE16
NA	NC	AE14
NA	NC	AE11
NA	NC	AE1
NA	NC	AD25
NA	NC	AD2
NA	NC	AD1
NA	NC	AA6
NA	NC	AA25
NA	NC	AA21
NA	NC	AA2
NA	NC	A3
NA	NC	A25
NA	NC	A2
NA	NC	A15
NA	VCCINT	G7
NA	VCCINT	G20
NA	VCCINT	H8
NA	VCCINT	H19
NA	VCCINT	J9

Table 3: FG676 Fine-Pitch BGA — XCV405E

Bank	Pin Description	Pin #
NA	VCCINT	J10
NA	VCCINT	J11
NA	VCCINT	J16
NA	VCCINT	J17
NA	VCCINT	J18
NA	VCCINT	K9
NA	VCCINT	K18
NA	VCCINT	L9
NA	VCCINT	L18
NA	VCCINT	T9
NA	VCCINT	T18
NA	VCCINT	U9
NA	VCCINT	U18
NA	VCCINT	V9
NA	VCCINT	V10
NA	VCCINT	V11
NA	VCCINT	V16
NA	VCCINT	V17
NA	VCCINT	V18
NA	VCCINT	Y7
NA	VCCINT	Y20
NA	VCCINT	W8
NA	VCCINT	W19
0	VCCO	J13
0	VCCO	J12
0	VCCO	H9
0	VCCO	H12
0	VCCO	H11
0	VCCO	H10
1	VCCO	J15
1	VCCO	J14
1	VCCO	H18
1	VCCO	H17
1	VCCO	H16

Table 3: FG676 Fine-Pitch BGA — XCV405E

Bank	Pin Description	Pin #
1	VCCO	H15
2	VCCO	N18
2	VCCO	M19
2	VCCO	M18
2	VCCO	L19
2	VCCO	K19
2	VCCO	J19
3	VCCO	V19
3	VCCO	U19
3	VCCO	T19
3	VCCO	R19
3	VCCO	R18
3	VCCO	P18
4	VCCO	W18
4	VCCO	W17
4	VCCO	W16
4	VCCO	W15
4	VCCO	V15
4	VCCO	V14
5	VCCO	W9
5	VCCO	W12
5	VCCO	W11
5	VCCO	W10
5	VCCO	V13
5	VCCO	V12
6	VCCO	V8
6	VCCO	U8
6	VCCO	T8
6	VCCO	R9
6	VCCO	R8
6	VCCO	P9
7	VCCO	N9
7	VCCO	M9
7	VCCO	M8
7	VCCO	L8

Table 3: FG676 Fine-Pitch BGA — XCV405E

Bank	Pin Description	Pin #
7	VCCO	K8
7	VCCO	J8
NA	GND	V25
NA	GND	V2
NA	GND	U17
NA	GND	U16
NA	GND	U15
NA	GND	U14
NA	GND	U13
NA	GND	U12
NA	GND	U11
NA	GND	U10
NA	GND	T17
NA	GND	T16
NA	GND	T15
NA	GND	T14
NA	GND	T13
NA	GND	T12
NA	GND	T11
NA	GND	T10
NA	GND	R17
NA	GND	R16
NA	GND	R15
NA	GND	R14
NA	GND	R13
NA	GND	R12
NA	GND	R11
NA	GND	R10
NA	GND	P25
NA	GND	P17
NA	GND	P16
NA	GND	P15
NA	GND	P14
NA	GND	P13

Table 3: FG676 Fine-Pitch BGA — XCV405E

Bank	Pin Description	Pin #
NA	GND	P12
NA	GND	P11
NA	GND	P10
NA	GND	N2
NA	GND	N17
NA	GND	N16
NA	GND	N15
NA	GND	N14
NA	GND	N13
NA	GND	N12
NA	GND	N11
NA	GND	N10
NA	GND	M17
NA	GND	M16
NA	GND	M15
NA	GND	M14
NA	GND	M13
NA	GND	M12
NA	GND	M11
NA	GND	M10
NA	GND	L17
NA	GND	L16
NA	GND	L15
NA	GND	L14
NA	GND	L13
NA	GND	L12
NA	GND	L11
NA	GND	L10
NA	GND	K17
NA	GND	K16
NA	GND	K15
NA	GND	K14
NA	GND	K13
NA	GND	K12
NA	GND	K11

Table 3: FG676 Fine-Pitch BGA — XCV405E

Bank	Pin Description	Pin #
NA	GND	K10
NA	GND	J25
NA	GND	J2
NA	GND	E5
NA	GND	E22
NA	GND	D4
NA	GND	D23
NA	GND	C3
NA	GND	C24
NA	GND	B9
NA	GND	B25
NA	GND	B2
NA	GND	B18
NA	GND	B14
NA	GND	AF26
NA	GND	AF1
NA	GND	AE9
NA	GND	AE25
NA	GND	AE2
NA	GND	AE18
NA	GND	AE13
NA	GND	AD3
NA	GND	AD24
NA	GND	AC4
NA	GND	AC23
NA	GND	AB5
NA	GND	AB22
NA	GND	A26
NA	GND	A1

FG676 Differential Pin Pairs

Virtex-E Extended Memory devices have differential pin pairs that can also provide other functions when not used as a differential pair. A √ in the AO column indicates that the pin pair can be used as an asynchronous output for all devices provided in this package.

Pairs with a note number in the AO column are device dependent. They can have asynchronous outputs if the pin pair is in the same CLB row and column in the device. Numbers in this column refer to footnotes that indicate which devices have pin pairs that can be asynchronous outputs. The Other Functions column indicates alternative function(s) not available when the pair is used as a differential pair or differential clock.

Table 4: FG676 Fine-Pitch BGA Differential Pin Pair Summary — XCV405E

Pair	Bank	P Pin	N Pin	AO	Other Functions
Global Differential Clock					
3	0	E13	B13	NA	IO_DLL_L21N
2	1	C13	F14	NA	IO_DLL_L21P
1	5	AB13	AF13	NA	IO_DLL_L115N
0	4	AA14	AC14	NA	IO_DLL_L115P
IOLVDS Total Pairs: 183, Asynchronous Output Pairs: 97					
0	0	F7	C4	NA	-
1	0	C5	G8	√	-
2	0	E7	D6	√	VREF
3	0	F8	A4	NA	-
4	0	D7	B5	NA	-
5	0	G9	E8	√	VREF
6	0	F9	A5	√	-
7	0	C7	D8	NA	-
8	0	E9	B7	NA	-
9	0	D9	A7	NA	-
10	0	G10	B8	NA	VREF
11	0	F10	C9	√	-
12	0	E10	A8	NA	-
13	0	D10	G11	√	-
14	0	F11	B10	√	-
15	0	E11	C10	NA	-

Table 4: FG676 Fine-Pitch BGA Differential Pin Pair Summary — XCV405E

Pair	Bank	P Pin	N Pin	AO	Other Functions
16	0	D11	G12	√	-
17	0	F12	C11	√	VREF
18	0	E12	A11	√	-
19	0	C12	D12	NA	-
20	0	H13	A12	NA	VREF
21	1	F14	B13	NA	IO_LVDS_DLL
22	1	F13	E14	NA	-
23	1	A14	D14	NA	VREF
24	1	H14	C14	NA	-
25	1	C15	G14	√	-
26	1	D15	E15	√	VREF
27	1	F15	C16	√	-
28	1	D16	G15	-	-
29	1	A17	E16	√	-
30	1	E17	C17	√	-
31	1	D17	F16	NA	-
32	1	C18	F17	√	-
33	1	G16	A18	√	VREF
34	1	G17	C19	√	-
35	1	B19	D18	NA	-
36	1	E18	D19	NA	-
37	1	B20	F18	√	-
38	1	C20	G19	√	VREF
39	1	E19	G18	√	-
40	1	D20	A21	√	-
41	1	C21	F19	√	VREF
42	1	E20	B22	√	-
43	1	D21	A23	2	-
44	1	E21	C22	√	CS
45	2	E23	F22	√	DIN, D0
46	2	E24	F20	√	-
47	2	G21	G22	2	-
48	2	F24	H20	1	VREF
49	2	E25	H21	1	-

Table 4: FG676 Fine-Pitch BGA Differential Pin Pair Summary — XCV405E

Pair	Bank	P Pin	N Pin	AO	Other Functions
50	2	F23	G23	√	-
51	2	H23	J20	√	VREF
52	2	G24	H22	√	-
53	2	J21	G25	2	-
54	2	G26	J22	1	-
55	2	H24	J23	√	-
56	2	J24	K20	√	VREF
57	2	K22	K21	√	D2
58	2	H25	K23	√	-
59	2	L20	J26	2	-
60	2	K25	L22	1	-
61	2	L21	L23	1	-
62	2	M20	L24	1	-
63	2	M23	M22	√	D3
64	2	L26	M21	√	-
65	2	N19	M24	2	-
66	2	M26	N20	1	VREF
67	2	N24	N21	√	-
68	2	N23	N22	√	-
69	3	P21	P23	√	-
70	3	P22	R25	1	VREF
71	3	P19	P20	2	-
72	3	R21	R22	√	-
73	3	R24	R23	√	VREF
74	3	T24	R20	1	-
75	3	T22	U24	1	-
76	3	T23	U25	1	-
77	3	T21	U20	2	-
78	3	U22	V26	√	-
79	3	T20	U23	√	D5
80	3	V24	U21	√	VREF
81	3	V23	W24	√	-
82	3	V22	W26	NA	-
83	3	Y25	V21	NA	-

Table 4: FG676 Fine-Pitch BGA Differential Pin Pair Summary — XCV405E

Pair	Bank	P Pin	N Pin	AO	Other Functions
84	3	V20	AA26	√	-
85	3	Y24	W23	√	VREF
86	3	AA24	Y23	NA	-
87	3	AB26	W21	NA	-
88	3	Y22	W22	NA	VREF
89	3	AA23	AB24	NA	-
90	3	W20	AC24	√	-
91	3	AB23	Y21	√	INIT
92	4	AC22	AD26	√	-
93	4	AD23	AA20	NA1	-
94	4	Y19	AC21	√	-
95	4	AD22	AB20	√	VREF
96	4	AE22	Y18	NA	-
97	4	AF22	AA19	NA	-
98	4	AD21	AB19	√	VREF
99	4	AC20	AA18	√	-
100	4	AC19	AD20	NA	-
101	4	AF20	AB18	NA	-
102	4	AD19	Y17	NA	-
103	4	AE19	AD18	NA	VREF
104	4	AF19	AA17	√	-
105	4	AC17	AB17	NA	-
106	4	Y16	AE17	√	-
107	4	AF17	AA16	√	-
108	4	AD17	AB16	NA	-
109	4	AC16	AD16	√	-
110	4	AC15	Y15	√	VREF
111	4	AD15	AA15	√	-
112	4	W14	AB15	NA	-
113	4	AF15	Y14	NA	VREF
114	4	AD14	AB14	NA	-
115	5	AC14	AF13	NA	IO_LVDS_DLL
116	5	AA13	AF12	NA	VREF
117	5	AC13	W13	NA	-

Table 4: FG676 Fine-Pitch BGA Differential Pin Pair Summary — XCV405E

Pair	Bank	P Pin	N Pin	AO	Other Functions
118	5	AA12	AD12	√	-
119	5	AC12	AB12	√	VREF
120	5	AD11	Y12	√	-
121	5	AB11	AD10	NA	-
122	5	AC11	AE10	√	-
123	5	AC10	AA11	√	-
124	5	Y11	AD9	NA	-
125	5	AB10	AF9	√	-
126	5	AD8	AA10	√	VREF
127	5	AE8	Y10	√	-
128	5	AC9	AF8	NA	-
129	5	AF7	AB9	NA	-
130	5	AA9	AF6	√	-
131	5	AC8	AC7	√	VREF
132	5	AD6	Y9	√	-
133	5	AE5	AA8	√	-
134	5	AC6	AB8	√	VREF
135	5	AD5	AA7	√	-
136	5	AF4	AC5	NA	-
137	6	AC3	AA5	√	-
138	6	AB4	AC2	√	-
139	6	AA4	W6	NA	-
140	6	Y5	AB3	NA	VREF
141	6	V7	AB2	NA	-
142	6	Y4	AB1	√	-
143	6	W5	V5	√	VREF
144	6	V6	AA1	√	-
145	6	Y3	W4	NA	-
146	6	U7	Y1	NA	-
147	6	V4	W1	√	-
148	6	U6	W2	√	VREF
149	6	T5	V3	√	-
150	6	U4	U5	√	-
151	6	U3	T7	NA	-

Table 4: FG676 Fine-Pitch BGA Differential Pin Pair Summary — XCV405E

Pair	Bank	P Pin	N Pin	AO	Other Functions
152	6	T6	U2	NA	-
153	6	T4	U1	NA	-
154	6	T3	R7	NA	-
155	6	R6	R4	√	VREF
156	6	R5	R3	√	-
157	6	P7	P8	NA	-
158	6	P6	R1	NA	VREF
159	6	P4	P5	√	-
160	7	N8	N5	√	-
161	7	N3	N6	√	-
162	7	M2	N4	NA	VREF
163	7	M7	N7	NA	-
164	7	M3	M6	√	-
165	7	M5	M4	√	VREF
166	7	L7	L3	NA	-
167	7	K2	L6	NA	-
168	7	K1	L4	NA	-
169	7	L5	K3	NA	-
170	7	J3	K5	√	-
171	7	J4	K4	√	-
172	7	K6	H3	√	VREF
173	7	G3	K7	√	-
174	7	H1	J5	NA	-
175	7	J6	G2	NA	-
176	7	F1	J7	√	-
177	7	G4	H4	√	VREF
178	7	H5	F3	NA	-
179	7	H6	E2	NA	-
180	7	F4	G5	NA	VREF
181	7	G6	H7	NA	-
182	7	E4	E3	√	-

FG900 Fine-Pitch Ball Grid Array Package

The XCV812E Virtex-E Extended Memory devices are available in the FG900 fine-pitch BGA package. Pins labeled IO_VREF can be used as either. If the pin is not used as V_{REF} it can be used as general I/O. Immediately following Table 5, see Table 6 for FG900 package Differential Pair information.

Table 5: FG900 Fine-Pitch BGA Package — XCV812E

Bank	Description	Pin
0	GCK3	C15
0	IO	A7
0	IO	A13
0	IO	C9
0	IO	C10
0	IO	D10
0	IO	E6
0	IO	F7
0	IO	F9
0	IO	F15
0	IO	G12
0	IO	G15
0	IO	H15
0	IO	J10
0	IO	K12
0	IO_VREF	A9
0	IO_L1N_Y	D5
0	IO_L1P_Y	G8
0	IO_L2N_Y	A3
0	IO_L2P_Y	H9
0	IO_L4N_YY	A4
0	IO_L4P_YY	D6
0	IO_VREF_L5N_YY	E7
0	IO_L5P_YY	B5
0	IO_L6N	A5
0	IO_L6P	F8
0	IO_L7N	D7
0	IO_L7P	N11

Table 5: FG900 Fine-Pitch BGA Package — XCV812E

Bank	Description	Pin
0	IO_L8N_YY	G9
0	IO_L8P_YY	E8
0	IO_VREF_L9N_YY	A6
0	IO_L9P_YY	J11
0	IO_L10N	C7
0	IO_L10P	B7
0	IO_L11N	C8
0	IO_L11P	H10
0	IO_L12N_YY	G10
0	IO_L12P_YY	F10
0	IO_VREF_L13N_YY	A8
0	IO_L13P_YY	H11
0	IO_L15N	B9
0	IO_L15P	J12
0	IO_L17N	G11
0	IO_L17P	B10
0	IO_L19N_Y	H13
0	IO_L19P_Y	F11
0	IO_L20N_Y	E11
0	IO_L20P_Y	D11
0	IO_L22N_YY	F12
0	IO_L22P_YY	C11
0	IO_VREF_L23N_YY	A10
0	IO_L23P_YY	D12
0	IO_L24N	E12
0	IO_L24P	A11
0	IO_L25N	G13
0	IO_L25P	B12
0	IO_L26N_YY	A12
0	IO_L26P_YY	K13
0	IO_VREF_L27N_YY	F13
0	IO_L27P_YY	B13
0	IO_L28N	G14
0	IO_L28P	E13

Table 5: FG900 Fine-Pitch BGA Package — XCV812E

Bank	Description	Pin
0	IO_L29N	D14
0	IO_L29P	B14
0	IO_L30N_YY	A14
0	IO_L30P_YY	J14
0	IO_VREF_L31N_YY	K14
0	IO_L31P_YY	J15
0	IO_LVDS_DLL_L34N	A15
1	Gck2	E15
1	IO	B18
1	IO	B21
1	IO	B28
1	IO	C23
1	IO	C26
1	IO	D20
1	IO	D23
1	IO_LVDS_DLL_L34P	E16
1	IO_L35N	B16
1	IO_L35P	F16
1	IO_L36N	A16
1	IO_L36P	H16
1	IO_L37N_YY	C16
1	IO_VREF_L37P_YY	K15
1	IO_L38N_YY	K16
1	IO_L38P_YY	G16
1	IO_L39N	A17
1	IO_L39P	E17
1	IO_L40N	F17
1	IO_L40P	C17
1	IO_L41N_YY	E18
1	IO_VREF_L41P_YY	A18
1	IO_L42N_YY	D18
1	IO_L42P_YY	A19
1	IO_L43N	B19

Table 5: FG900 Fine-Pitch BGA Package — XCV812E

Bank	Description	Pin
1	IO_L43P	G18
1	IO_L44N	D19
1	IO_L44P	H18
1	IO_L45N_YY	F18
1	IO_VREF_L45P_YY	F19
1	IO_L46N_YY	B20
1	IO_L46P_YY	K17
1	IO_L48N_Y	G19
1	IO_L48P_Y	C20
1	IO_L49N_Y	K18
1	IO_L49P_Y	E20
1	IO_L51N_YY	F20
1	IO_L51P_YY	A21
1	IO_L52N_YY	C21
1	IO_VREF_L52P_YY	A22
1	IO_L53N	H19
1	IO_L53P	B22
1	IO_L54N	E21
1	IO_L54P	D22
1	IO_L55N_YY	F21
1	IO_VREF_L55P_YY	C22
1	IO_L56N_YY	H20
1	IO_L56P_YY	E22
1	IO_L57N	G21
1	IO_L57P	A23
1	IO_L58N	A24
1	IO_L58P	K19
1	IO_L59N_YY	C24
1	IO_VREF_L59P_YY	B24
1	IO_L60N_YY	H21
1	IO_L60P_YY	G22
1	IO_L61N	E23
1	IO_L61P	C25
1	IO_L62N	D24

Table 5: FG900 Fine-Pitch BGA Package — XCV812E

Bank	Description	Pin
1	IO_L62P	A26
1	IO_L63N_YY	B26
1	IO_VREF_L63P_YY	K20
1	IO_L64N_YY	D25
1	IO_L64P_YY	J21
1	IO_L66N_Y	B27
1	IO_L66P_Y	G23
1	IO_L67N_Y	A27
1	IO_L67P_Y	F24
1	IO_WRITE_L69N_YY	K21
1	IO_CS_L69P_YY	C27
2	IO	D28
2	IO	F27
2	IO	H25
2	IO	J25
2	IO	J28
2	IO	K28
2	IO	K30
2	IO	M23
2	IO	N20
2	IO	N23
2	IO	R27
2	IO	R28
2	IO	R30
2	IO_DOUT_BUSY_L70P_YY	J22
2	IO_DIN_D0_L70N_YY	E27
2	IO_L72P_Y	G25
2	IO_L72N_Y	E25
2	IO_L73P	E28
2	IO_L73N	C30
2	IO_L75P	D30
2	IO_L75N	J23
2	IO_VREF_L76P_Y	L21

Table 5: FG900 Fine-Pitch BGA Package — XCV812E

Bank	Description	Pin
2	IO_L76N_Y	F28
2	IO_L77P_YY	G28
2	IO_L77N_YY	E30
2	IO_L78P	G27
2	IO_L78N	E29
2	IO_L79P	K23
2	IO_L79N	H26
2	IO_VREF_L80P_YY	F30
2	IO_L80N_YY	L22
2	IO_L81P_YY	H27
2	IO_L81N_YY	G29
2	IO_L82P_Y	G30
2	IO_L82N_Y	M21
2	IO_L83P	J24
2	IO_L83N	J26
2	IO_VREF_L84P	H30
2	IO_L84N	L23
2	IO_L86P	J29
2	IO_L86N	K24
2	IO_VREF	J30
2	IO_D1_L88P	M22
2	IO_D2_L88N	K29
2	IO_L90P_Y	N21
2	IO_L90N_Y	K25
2	IO_L91P	L24
2	IO_L91N	L27
2	IO_L93P	L26
2	IO_L93N	L28
2	IO_VREF_L94P_Y	L30
2	IO_L94N_Y	M27
2	IO_L95P_YY	M26
2	IO_L95N_YY	M29
2	IO_L96P	N29
2	IO_L96N	M30

Table 5: FG900 Fine-Pitch BGA Package — XCV812E

Bank	Description	Pin
2	IO_L97P	N25
2	IO_L97N	N27
2	IO_VREF_L98P_YY	N30
2	IO_D3_L98N_YY	P21
2	IO_L99P_YY	N26
2	IO_L99N_YY	P28
2	IO_L100P_Y	P29
2	IO_L100N_Y	N24
2	IO_L101P	P22
2	IO_L101N	R26
2	IO_VREF_2_L102P	P25
2	IO_L102N	R29
2	IO_L104P	R25
2	IO_L104N	T30
2	IO_L106P	R24
3	IO	T24
3	IO	V24
3	IO	Y21
3	IO	Y27
3	IO	AB27
3	IO	AF28
3	IO	AG30
3	IO_L106N	U29
3	IO_L107P	R22
3	IO_L107N	T27
3	IO_L108P	R23
3	IO_L108N	T28
3	IO_L109P	T21
3	IO_VREF_L109N	T25
3	IO_L110P	U28
3	IO_L110N	U30
3	IO_L111P_Y	T23
3	IO_L111N_Y	U27

Table 5: FG900 Fine-Pitch BGA Package — XCV812E

Bank	Description	Pin
3	IO_L112P_YY	U25
3	IO_L112N_YY	V27
3	IO_D4_L113P_YY	U24
3	IO_VREF_L113N_YY	V29
3	IO_L114P	W30
3	IO_L114N	U22
3	IO_L115P	U21
3	IO_L115N	W29
3	IO_L116P_YY	V26
3	IO_L116N_YY	W27
3	IO_L117P_Y	W26
3	IO_VREF_L117N_Y	Y29
3	IO_L118P	W25
3	IO_L118N	Y30
3	IO_L120P	AA30
3	IO_L120N	W24
3	IO_L121P_Y	AA29
3	IO_L121N_Y	V20
3	IO_L123P_YY	Y26
3	IO_D5_L123N_YY	AB30
3	IO_D6_L124P_YY	V21
3	IO_VREF_L124N_YY	AA28
3	IO_L125P	Y25
3	IO_L125N	AA27
3	IO_L126P	W22
3	IO_L126N	Y23
3	IO_L127P	Y24
3	IO_VREF_L127N	AB28
3	IO_L128P	AC30
3	IO_L128N	AA25
3	IO_L129P_Y	W21
3	IO_L129N_Y	AA24
3	IO_L130P_YY	AB26
3	IO_L130N_YY	AD30

Table 5: FG900 Fine-Pitch BGA Package — XCV812E

Bank	Description	Pin
3	IO_L131P_YY	Y22
3	IO_VREF_L131N_YY	AC27
3	IO_L132P	AD28
3	IO_L132N	AB25
3	IO_L133P	AC26
3	IO_L133N	AE30
3	IO_L134P_YY	AD27
3	IO_L134N_YY	AF30
3	IO_L135P_Y	AF29
3	IO_VREF_L135N_Y	AB24
3	IO_L136P	AB23
3	IO_L136N	AE28
3	IO_L138P	AE26
3	IO_L138N	AG29
3	IO_L139P_Y	AH30
3	IO_L139N_Y	AC24
3	IO_D7_L141P_YY	AH29
3	IO_INIT_L141N_YY	AA22
4	GCK0	AJ16
4	IO	AB19
4	IO	AC16
4	IO	AC19
4	IO	AD19
4	IO	AD20
4	IO	AE21
4	IO	AF19
4	IO	AH17
4	IO	AH23
4	IO	AH26
4	IO	AH27
4	IO	AK18
4	IO_VREF_4	AA18
4	IO_L142P_YY	AF27

Table 5: FG900 Fine-Pitch BGA Package — XCV812E

Bank	Description	Pin
4	IO_L142N_YY	AK28
4	IO_L144P_Y	AD23
4	IO_L144N_Y	AJ27
4	IO_L145P_Y	AB21
4	IO_L145N_Y	AF25
4	IO_L147P_YY	AA21
4	IO_L147N_YY	AG25
4	IO_VREF_4_L148P_YY	AJ26
4	IO_L148N_YY	AD22
4	IO_L149P	AA20
4	IO_L149N	AH25
4	IO_L150P	AC21
4	IO_L150N	AF24
4	IO_L151P_YY	AG24
4	IO_L151N_YY	AK26
4	IO_VREF_4_L152P_YY	AJ24
4	IO_L152N_YY	AF23
4	IO_L153P	AE23
4	IO_L153N	AB20
4	IO_L154P	AC20
4	IO_L154N	AG23
4	IO_L155P_YY	AF22
4	IO_L155N_YY	AE22
4	IO_VREF_4_L156P_YY	AJ22
4	IO_L156N_YY	AG22
4	IO_L158P	AA19
4	IO_L158N	AF21
4	IO_L160P	AG21
4	IO_L160N	AK23
4	IO_L162P_Y	AE20
4	IO_L162N_Y	AJ21
4	IO_L163P_Y	AG20
4	IO_L163N_Y	AF20
4	IO_L165P_YY	AJ20

Table 5: FG900 Fine-Pitch BGA Package — XCV812E

Bank	Description	Pin
4	IO_L165N_YY	AE19
4	IO_VREF_4_L166P_YY	AK22
4	IO_L166N_YY	AH20
4	IO_L167P	AG19
4	IO_L167N	AB17
4	IO_L168P	AJ19
4	IO_L168N	AD17
4	IO_L169P_YY	AA16
4	IO_L169N_YY	AA17
4	IO_VREF_4_L170P_YY	AK21
4	IO_L170N_YY	AB16
4	IO_L171P	AG18
4	IO_L171N	AK20
4	IO_L172P	AK19
4	IO_L172N	AD16
4	IO_L173P_YY	AE16
4	IO_L173N_YY	AE17
4	IO_VREF_4_L174P_YY	AG17
4	IO_L174N_YY	AJ17
4	IO_L176P	AG16
4	IO_L176N	AK17
4	IO_LVDS_DLL_L177P	AF16
5	GCK1	AK16
5	IO	AD8
5	IO	AD14
5	IO	AE10
5	IO	AE12
5	IO	AG15
5	IO	AH5
5	IO	AH8
5	IO	AK12
5	IO_LVDS_DLL_L177N	AH16
5	IO_L179P	AB15

Table 5: FG900 Fine-Pitch BGA Package — XCV812E

Bank	Description	Pin
5	IO_L179N	AF15
5	IO_L180P_YY	AA15
5	IO_VREF_5_L180N_YY	AF14
5	IO_L181P_YY	AH15
5	IO_L181N_YY	AK15
5	IO_L182P	AB14
5	IO_L182N	AF13
5	IO_L183P	AH14
5	IO_L183N	AJ14
5	IO_L184P_YY	AE14
5	IO_VREF_5_L184N_YY	AG13
5	IO_L185P_YY	AK13
5	IO_L185N_YY	AD13
5	IO_L186P	AE13
5	IO_L186N	AF12
5	IO_L187P	AC13
5	IO_L187N	AA13
5	IO_L188P_YY	AA12
5	IO_VREF_5_L188N_YY	AJ12
5	IO_L189P_YY	AB12
5	IO_L189N_YY	AE11
5	IO_L191P_Y	AG11
5	IO_L191N_Y	AF11
5	IO_L192P_Y	AH11
5	IO_L192N_Y	AJ11
5	IO_L194P_YY	AD12
5	IO_L194N_YY	AK11
5	IO_L195P_YY	AJ10
5	IO_VREF_5_L195N_YY	AC12
5	IO_L196P	AK10
5	IO_L196N	AD11
5	IO_L197P	AJ9
5	IO_L197N	AE9
5	IO_L198P_YY	AH10

Table 5: FG900 Fine-Pitch BGA Package — XCV812E

Bank	Description	Pin
5	IO_VREF_5_L198N_YY	AF9
5	IO_L199P_YY	AH9
5	IO_L199N_YY	AK9
5	IO_L200P	AF8
5	IO_L200N	AB11
5	IO_L201P	AC11
5	IO_L201N	AG8
5	IO_L202P_YY	AK8
5	IO_VREF_5_L202N_YY	AF7
5	IO_L203P_YY	AG7
5	IO_L203N_YY	AK7
5	IO_L204P	AJ7
5	IO_L204N	AD10
5	IO_L205P	AH6
5	IO_L205N	AC10
5	IO_L206P_YY	AD9
5	IO_VREF_5_L206N_YY	AG6
5	IO_L207P_YY	AB10
5	IO_L207N_YY	AJ5
5	IO_L209P_Y	AC9
5	IO_L209N_Y	AJ4
5	IO_L210P_Y	AG5
5	IO_L210N_Y	AK4
6	IO	T6
6	IO	U1
6	IO	U6
6	IO	V7
6	IO	V8
6	IO	W10
6	IO	Y10
6	IO	AA2
6	IO	AA4
6	IO	AD1

Table 5: FG900 Fine-Pitch BGA Package — XCV812E

Bank	Description	Pin
6	IO	AD6
6	IO	AG2
6	IO_L212N_YY	AF3
6	IO_L212P_YY	AC6
6	IO_L214N_Y	AB9
6	IO_L214P_Y	AE4
6	IO_L215N	AE3
6	IO_L215P	AH1
6	IO_L217N	AG1
6	IO_L217P	AA10
6	IO_VREF_L218N_Y	AA9
6	IO_L218P_Y	AD4
6	IO_L219N_YY	AD5
6	IO_L219P_YY	AD2
6	IO_L220N	AD3
6	IO_L220P	AF2
6	IO_L221N	AA8
6	IO_L221P	AA7
6	IO_VREF_L222N_YY	AF1
6	IO_L222P_YY	Y9
6	IO_L223N_YY	AB6
6	IO_L223P_YY	AC4
6	IO_L224N_Y	AE1
6	IO_L224P_Y	W8
6	IO_L225N	Y8
6	IO_L225P	AB4
6	IO_VREF_L226N	AB3
6	IO_L226P	W9
6	IO_L228N	AB1
6	IO_L228P	V10
6	IO_VREF	AC1
6	IO_L230N	V11
6	IO_L230P	AA3
6	IO_L232N_Y	W7

Table 5: FG900 Fine-Pitch BGA Package — XCV812E

Bank	Description	Pin
6	IO_L232P_Y	AA6
6	IO_L233N	Y6
6	IO_L233P	Y4
6	IO_L235N	Y3
6	IO_L235P	Y2
6	IO_VREF_L236N_Y	Y5
6	IO_L236P_Y	W5
6	IO_L237N_YY	W4
6	IO_L237P_YY	W6
6	IO_L238N	V6
6	IO_L238P	W2
6	IO_L239N	U9
6	IO_L239P	V4
6	IO_VREF_L240N_YY	AB2
6	IO_L240P_YY	T8
6	IO_L241N_YY	U5
6	IO_L241P_YY	W1
6	IO_L242N_Y	Y1
6	IO_L242P_Y	T9
6	IO_L243N	T7
6	IO_L243P	U3
6	IO_VREF_L244N	T5
6	IO_L244P	V2
6	IO_L246N	T4
6	IO_L246P	U2
6	IO_L247N	T1
7	IO	D1
7	IO	E3
7	IO	J4
7	IO	J6
7	IO	K10
7	IO	L3
7	IO	M7

Table 5: FG900 Fine-Pitch BGA Package — XCV812E

Bank	Description	Pin
7	IO	N8
7	IO	R5
7	IO_L247P	R10
7	IO_L249N	R8
7	IO_L249P	R4
7	IO_L250N	R7
7	IO_L250P	R3
7	IO_L251N	P10
7	IO_VREF_L251P	P6
7	IO_L252N	P5
7	IO_L252P	P2
7	IO_L253N_Y	P7
7	IO_L253P_Y	P4
7	IO_L254N_YY	N4
7	IO_L254P_YY	R2
7	IO_L255N_YY	N7
7	IO_VREF_L255P_YY	P1
7	IO_L256N	M6
7	IO_L256P	N6
7	IO_L257N	N5
7	IO_L257P	N1
7	IO_L258N_YY	M4
7	IO_L258P_YY	M5
7	IO_L259N_Y	M2
7	IO_VREF_L259P_Y	M1
7	IO_L260N	L4
7	IO_L260P	L2
7	IO_L262N	L1
7	IO_L262P	M8
7	IO_L263N_Y	K2
7	IO_L263P_Y	M9
7	IO_L265N_YY	K5
7	IO_L265P_YY	K1
7	IO_L266N_YY	L6

Table 5: FG900 Fine-Pitch BGA Package — XCV812E

Bank	Description	Pin
7	IO_VREF_L266P_YY	K3
7	IO_L267N	L7
7	IO_L267P	K4
7	IO_L268N	L8
7	IO_L268P	J5
7	IO_L269N	K6
7	IO_VREF_L269P	H4
7	IO_L270N	H1
7	IO_L270P	K7
7	IO_L271N_Y	J7
7	IO_L271P_Y	J2
7	IO_L272N_YY	H5
7	IO_L272P_YY	G2
7	IO_L273N_YY	L9
7	IO_VREF_L273P_YY	G5
7	IO_L274N	F3
7	IO_L274P	K8
7	IO_L275N	G3
7	IO_L275P	E1
7	IO_L276N_YY	H6
7	IO_L276P_YY	E2
7	IO_L277N_Y	E4
7	IO_VREF_L277P_Y	K9
7	IO_L278N	J8
7	IO_L278P	F4
7	IO_L280N	G6
7	IO_L280P	C2
7	IO_L281N_Y	D2
7	IO_L281P_Y	F5
2	DONE	AJ28
NA	DXN	AJ3
NA	DXP	AH4
3	CCLK	F26

Table 5: FG900 Fine-Pitch BGA Package — XCV812E

Bank	Description	Pin
NA	M0	AF4
NA	M1	AC7
NA	M2	AK3
NA	PROGRAM	AG28
NA	TCK	B3
NA	TDI	H22
2	TDO	D26
NA	TMS	C1
NA	VCCINT	L11
NA	VCCINT	L12
NA	VCCINT	L19
NA	VCCINT	L20
NA	VCCINT	M11
NA	VCCINT	M12
NA	VCCINT	M19
NA	VCCINT	M20
NA	VCCINT	N13
NA	VCCINT	N14
NA	VCCINT	N15
NA	VCCINT	N16
NA	VCCINT	N17
NA	VCCINT	N18
NA	VCCINT	P13
NA	VCCINT	P18
NA	VCCINT	R13
NA	VCCINT	R18
NA	VCCINT	T13
NA	VCCINT	T18
NA	VCCINT	U18
NA	VCCINT	U13
NA	VCCINT	V13
NA	VCCINT	V14
NA	VCCINT	V15

Table 5: FG900 Fine-Pitch BGA Package — XCV812E

Bank	Description	Pin
NA	VCCINT	V16
NA	VCCINT	V17
NA	VCCINT	V18
NA	VCCINT	W11
NA	VCCINT	W12
NA	VCCINT	W19
NA	VCCINT	W20
NA	VCCINT	Y11
NA	VCCINT	Y12
NA	VCCINT	Y19
NA	VCCINT	Y20
NA	VCCO_0	B6
NA	VCCO_0	M15
NA	VCCO_0	M14
NA	VCCO_0	L15
NA	VCCO_0	L14
NA	VCCO_0	H14
NA	VCCO_0	M13
NA	VCCO_0	C12
NA	VCCO_1	B25
NA	VCCO_1	C19
NA	VCCO_1	M18
NA	VCCO_1	M17
NA	VCCO_1	L17
NA	VCCO_1	H17
NA	VCCO_1	L16
NA	VCCO_1	M16
NA	VCCO_2	F29
NA	VCCO_2	M28
NA	VCCO_2	P23
NA	VCCO_2	R20
NA	VCCO_2	P20
NA	VCCO_2	R19

Table 5: FG900 Fine-Pitch BGA Package — XCV812E

Bank	Description	Pin
NA	VCCO_2	N19
NA	VCCO_2	P19
NA	VCCO_3	AE29
NA	VCCO_3	W28
NA	VCCO_3	U23
NA	VCCO_3	U20
NA	VCCO_3	T20
NA	VCCO_3	V19
NA	VCCO_3	T19
NA	VCCO_3	U19
NA	VCCO_4	AJ25
NA	VCCO_4	AH19
NA	VCCO_4	W18
NA	VCCO_4	AC17
NA	VCCO_4	Y17
NA	VCCO_4	W17
NA	VCCO_4	W16
NA	VCCO_4	Y16
NA	VCCO_5	AJ6
NA	VCCO_5	Y15
NA	VCCO_5	W15
NA	VCCO_5	AC14
NA	VCCO_5	Y14
NA	VCCO_5	W14
NA	VCCO_5	W13
NA	VCCO_5	AH12
NA	VCCO_6	AE2
NA	VCCO_6	V12
NA	VCCO_6	U12
NA	VCCO_6	T12
NA	VCCO_6	U11
NA	VCCO_6	T11
NA	VCCO_6	U8
NA	VCCO_6	W3

Table 5: FG900 Fine-Pitch BGA Package — XCV812E

Bank	Description	Pin
NA	VCCO_7	F2
NA	VCCO_7	R12
NA	VCCO_7	P12
NA	VCCO_7	N12
NA	VCCO_7	R11
NA	VCCO_7	P11
NA	VCCO_7	P8
NA	VCCO_7	M3
NA	GND	Y18
NA	GND	AH7
NA	GND	AK30
NA	GND	AJ30
NA	GND	B30
NA	GND	A30
NA	GND	AK29
NA	GND	AJ29
NA	GND	AC29
NA	GND	H29
NA	GND	B29
NA	GND	A29
NA	GND	AH28
NA	GND	V28
NA	GND	N28
NA	GND	C28
NA	GND	AG27
NA	GND	D27
NA	GND	AF26
NA	GND	E26
NA	GND	F25
NA	GND	AE25
NA	GND	G24
NA	GND	AJ23
NA	GND	AD24

Table 5: FG900 Fine-Pitch BGA Package — XCV812E

Bank	Description	Pin
NA	GND	H23
NA	GND	B23
NA	GND	AC23
NA	GND	AB22
NA	GND	V22
NA	GND	N22
NA	GND	AH18
NA	GND	AB18
NA	GND	J18
NA	GND	C18
NA	GND	U17
NA	GND	T17
NA	GND	R17
NA	GND	P17
NA	GND	U16
NA	GND	T16
NA	GND	R16
NA	GND	P16
NA	GND	U15
NA	GND	T15
NA	GND	R15
NA	GND	P15
NA	GND	U14
NA	GND	T14
NA	GND	R14
NA	GND	P14
NA	GND	AH13
NA	GND	AB13
NA	GND	J13
NA	GND	C13
NA	GND	V9
NA	GND	N9
NA	GND	J9
NA	GND	AJ8

Table 5: FG900 Fine-Pitch BGA Package — XCV812E

Bank	Description	Pin
NA	GND	AC8
NA	GND	H8
NA	GND	AD7
NA	GND	B8
NA	GND	AE6
NA	GND	G7
NA	GND	F6
NA	GND	AF5
NA	GND	E5
NA	GND	AG4
NA	GND	D4
NA	GND	V3
NA	GND	N3
NA	GND	C3
NA	GND	AK2
NA	GND	AH3
NA	GND	AC2
NA	GND	H2
NA	GND	B2
NA	GND	A2
NA	GND	AK1
NA	GND	AJ2
NA	GND	AJ1
NA	GND	A1
NA	GND	B1

FG900 Differential Pin Pairs

Virtex-E Extended Memory devices have differential pin pairs that can also provide other functions when not used as a differential pair. A √ in the AO column indicates that the pin pair can be used as an asynchronous output for all devices provided in this package.

Pairs with a note number in the AO column are device dependent. They can have asynchronous outputs if the pin pair is in the same CLB row and column in the device. Numbers in this column refer to footnotes that indicate which devices have pin pairs that can be asynchronous outputs. The Other Functions column indicates alternative function(s) not available when the pair is used as a differential pair or differential clock.

Table 6: FG900 Differential Pin Pair Summary — XCV812E

Pair	Bank	P Pin	N Pin	AO	Other Functions
GCLK LVDS					
3	0	C15	A15	NA	IO LVDS 34
2	1	E15	E16	NA	IO LVDS 34
1	5	AK16	AH16	NA	IO LVDS 177
0	4	AJ16	AF16	NA	IO LVDS 177
IO LVDS					
Total Pairs: 235, Asynchronous Output Pairs: 85					
1	0	G8	D5	√	-
2	0	H9	A3	√	-
4	0	D6	A4	√	-
5	0	B5	E7	√	VREF
6	0	F8	A5	-	-
7	0	N11	D7	-	-
8	0	E8	G9	√	-
9	0	J11	A6	√	VREF
10	0	B7	C7	-	-
11	0	H10	C8	-	-
12	0	F10	G10	√	-
13	0	H11	A8	√	VREF
15	0	J12	B9	-	-
17	0	B10	G11	-	-
19	0	F11	H13	√	-
20	0	D11	E11	√	-
22	0	C11	F12	√	-
23	0	D12	A10	√	VREF
24	0	A11	E12	-	-

Table 6: FG900 Differential Pin Pair Summary — XCV812E

Pair	Bank	P Pin	N Pin	AO	Other Functions
25	0	B12	G13	-	-
26	0	K13	A12	√	-
27	0	B13	F13	√	VREF
28	0	E13	G14	-	-
29	0	B14	D14	-	-
30	0	J14	A14	√	-
31	0	J15	K14	√	VREF
34	1	E16	A15	-	GCLK LVDS 3/2
35	1	F16	B16	-	-
36	1	H16	A16	-	-
37	1	K15	C16	√	VREF
38	1	G16	K16	√	-
39	1	E17	A17	-	-
40	1	C17	F17	-	-
41	1	A18	E18	√	VREF
42	1	A19	D18	√	-
43	1	G18	B19	-	-
44	1	H18	D19	-	-
45	1	F19	F18	√	VREF
46	1	K17	B20	√	-
48	1	C20	G19	√	-
49	1	E20	K18	√	-
51	1	A21	F20	√	-
52	1	A22	C21	√	VREF
53	1	B22	H19	-	-
54	1	D22	E21	-	-
55	1	C22	F21	√	VREF
56	1	E22	H20	√	-
57	1	A23	G21	-	-
58	1	K19	A24	-	-
59	1	B24	C24	√	VREF
60	1	G22	H21	√	-
61	1	C25	E23	-	-
62	1	A26	D24	-	-
63	1	K20	B26	√	VREF
64	1	J21	D25	√	-
66	1	G23	B27	√	-

Table 6: FG900 Differential Pin Pair Summary — XCV812E

Pair	Bank	P Pin	N Pin	AO	Other Functions
67	1	F24	A27	√	-
69	1	C27	K21	√	CS
70	2	J22	E27	√	DIN_D0
72	2	G25	E25	√	-
73	2	E28	C30	-	-
75	2	D30	J23	-	-
76	2	L21	F28	√	VREF
77	2	G28	E30	√	-
78	2	G27	E29	-	-
79	2	K23	H26	-	-
80	2	F30	L22	√	VREF
81	2	H27	G29	√	-
82	2	G30	M21	√	-
83	2	J24	J26	-	-
84	2	H30	L23	-	VREF
86	2	J29	K24	-	-
88	2	M22	K29	-	D2
90	2	N21	K25	√	-
91	2	L24	L27	-	-
93	2	L26	L28	-	-
94	2	L30	M27	√	VREF
95	2	M26	M29	√	-
96	2	N29	M30	-	-
97	2	N25	N27	-	-
98	2	N30	P21	√	D3
99	2	N26	P28	√	-
100	2	P29	N24	√	-
101	2	P22	R26	-	-
102	2	P25	R29	-	VREF
104	2	R25	T30	-	-
106	3	R24	U29	-	TRDY
107	3	R22	T27	-	-
108	3	R23	T28	-	-
109	3	T21	T25	-	VREF
110	3	U28	U30	-	-
111	3	T23	U27	√	-
112	3	U25	V27	√	-

Table 6: FG900 Differential Pin Pair Summary — XCV812E

Pair	Bank	P Pin	N Pin	AO	Other Functions
113	3	U24	V29	√	VREF
114	3	W30	U22	-	-
115	3	U21	W29	-	-
116	3	V26	W27	√	-
117	3	W26	Y29	√	VREF
118	3	W25	Y30	-	-
120	3	AA30	W24	-	-
121	3	AA29	V20	√	-
123	3	Y26	AB30	√	D5
124	3	V21	AA28	√	VREF
125	3	Y25	AA27	-	-
126	3	W22	Y23	-	-
127	3	Y24	AB28	-	VREF
128	3	AC30	AA25	-	-
129	3	W21	AA24	√	-
130	3	AB26	AD30	√	-
131	3	Y22	AC27	√	VREF
132	3	AD28	AB25	-	-
133	3	AC26	AE30	-	-
134	3	AD27	AF30	√	-
135	3	AF29	AB24	√	VREF
136	3	AB23	AE28	-	-
138	3	AE26	AG29	-	-
139	3	AH30	AC24	√	-
141	3	AH29	AA22	√	INIT
142	4	AF27	AK28	√	-
144	4	AD23	AJ27	√	-
145	4	AB21	AF25	√	-
147	4	AA21	AG25	√	-
148	4	AJ26	AD22	√	VREF
149	4	AA20	AH25	-	-
150	4	AC21	AF24	-	-
151	4	AG24	AK26	√	-
152	4	AJ24	AF23	√	VREF
153	4	AE23	AB20	-	-
154	4	AC20	AG23	-	-
155	4	AF22	AE22	√	-

Table 6: FG900 Differential Pin Pair Summary — XCV812E

Pair	Bank	P Pin	N Pin	AO	Other Functions
156	4	AJ22	AG22	√	VREF
158	4	AA19	AF21	-	-
160	4	AG21	AK23	-	-
162	4	AE20	AJ21	√	-
163	4	AG20	AF20	√	-
165	4	AJ20	AE19	√	-
166	4	AK22	AH20	√	VREF
167	4	AG19	AB17	-	-
168	4	AJ19	AD17	-	-
169	4	AA16	AA17	√	-
170	4	AK21	AB16	√	VREF
171	4	AG18	AK20	-	-
172	4	AK19	AD16	-	-
173	4	AE16	AE17	√	-
174	4	AG17	AJ17	√	VREF
176	4	AG16	AK17	-	-
177	5	AF16	AH16	-	GCLK LVDS 1/0
179	5	AB15	AF15	-	-
180	5	AA15	AF14	√	VREF
181	5	AH15	AK15	√	-
182	5	AB14	AF13	-	-
183	5	AH14	AJ14	-	-
184	5	AE14	AG13	√	VREF
185	5	AK13	AD13	√	-
186	5	AE13	AF12	-	-
187	5	AC13	AA13	-	-
188	5	AA12	AJ12	√	VREF
189	5	AB12	AE11	√	-
191	5	AG11	AF11	√	-
192	5	AH11	AJ11	√	-
194	5	AD12	AK11	√	-
195	5	AJ10	AC12	√	VREF
196	5	AK10	AD11	-	-
197	5	AJ9	AE9	-	-
198	5	AH10	AF9	√	VREF
199	5	AH9	AK9	√	-
200	5	AF8	AB11	-	-

Table 6: FG900 Differential Pin Pair Summary — XCV812E

Pair	Bank	P Pin	N Pin	AO	Other Functions
201	5	AC11	AG8	-	-
202	5	AK8	AF7	√	VREF
203	5	AG7	AK7	√	-
204	5	AJ7	AD10	-	-
205	5	AH6	AC10	-	-
206	5	AD9	AG6	√	VREF
207	5	AB10	AJ5	√	-
209	5	AC9	AJ4	√	-
210	5	AG5	AK4	√	-
212	6	AC6	AF3	√	-
214	6	AE4	AB9	√	-
215	6	AH1	AE3	-	-
217	6	AA10	AG1	-	-
218	6	AD4	AA9	√	VREF
219	6	AD2	AD5	√	-
220	6	AF2	AD3	-	-
221	6	AA7	AA8	-	-
222	6	Y9	AF1	√	VREF
223	6	AC4	AB6	√	-
224	6	W8	AE1	√	-
225	6	AB4	Y8	-	-
226	6	W9	AB3	-	VREF
228	6	V10	AB1	-	-
230	6	AA3	V11	-	-
232	6	AA6	W7	√	-
233	6	Y4	Y6	-	-
235	6	Y2	Y3	-	-
236	6	W5	Y5	√	VREF
237	6	W6	W4	√	-
238	6	W2	V6	-	-
239	6	V4	U9	-	-
240	6	T8	AB2	√	VREF
241	6	W1	U5	√	-
242	6	T9	Y1	√	-
243	6	U3	T7	-	-
244	6	V2	T5	-	VREF
246	6	U2	T4	-	-

Table 6: FG900 Differential Pin Pair Summary — XCV812E

Pair	Bank	P Pin	N Pin	AO	Other Functions
247	7	R10	T1	-	IRDY
249	7	R4	R8	-	-
250	7	R3	R7	-	-
251	7	P6	P10	-	VREF
252	7	P2	P5	-	-
253	7	P4	P7	√	-
254	7	R2	N4	√	-
255	7	P1	N7	√	VREF
256	7	N6	M6	-	-
257	7	N1	N5	-	-
258	7	M5	M4	√	-
259	7	M1	M2	√	VREF
260	7	L2	L4	-	-
262	7	M8	L1	-	-
263	7	M9	K2	√	-
265	7	K1	K5	√	-
266	7	K3	L6	√	VREF
267	7	K4	L7	-	-
268	7	J5	L8	-	-
269	7	H4	K6	-	VREF
270	7	K7	H1	-	-
271	7	J2	J7	√	-
272	7	G2	H5	√	-
273	7	G5	L9	√	VREF
274	7	K8	F3	-	-
275	7	E1	G3	-	-
276	7	E2	H6	√	-
277	7	K9	E4	√	VREF
278	7	F4	J8	-	-
280	7	C2	G6	-	-
281	7	F5	D2	-	-

Virtex-E Extended Memory Device/Package Combinations and Maximum I/O

Virtex-E Extended Memory Series Maximum User I/O by Device/Package (Excluding Dedicated Clock Pins)		
Package	XCV405E	XCV812E
BG560	404	404
FG676	404	
FG900		556

Virtex-E Ordering Information

Virtex-II ordering information is shown in [Figure 1](#)

Example: XCV405E-6BG560C

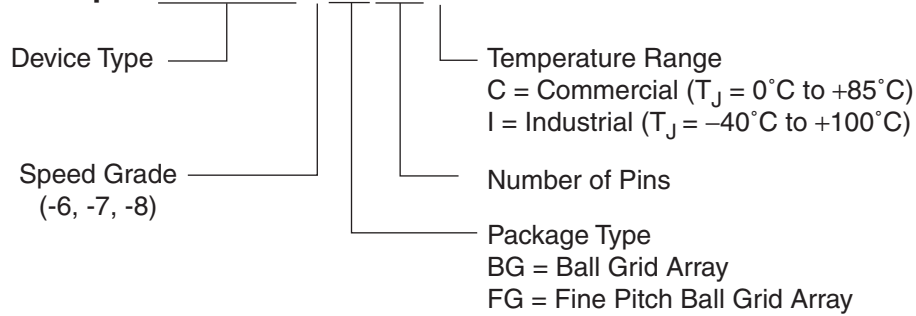

DS025_001_112000

Figure 1: Virtex Ordering Information

Revision History

The following table shows the revision history for this document.

Date	Version	Revision
03/23/2000	1.0	Initial Xilinx release.
08/01/2000	1.1	Accumulated edits and fixes. Upgrade to Preliminary. Preview -8 numbers added. Reformatted to adhere to corporate documentation style guidelines. Minor changes in BG560 pin-out table.
09/19/2000	1.2	<ul style="list-style-type: none"> In Table 3 (Module 4), FG676 Fine-Pitch BGA — XCV405E, the following pins are no longer labeled as VREF: B7, G16, G26, W26, AF20, AF8, Y1, H1. Min values added to Virtex-E Electrical Characteristics tables.
11/20/2000	1.3	<ul style="list-style-type: none"> Updated speed grade -8 numbers in Virtex-E Electrical Characteristics tables (Module 3). Updated minimums in Table 11 (Module 2), and added notes to Table 12 (Module 2). Added to note 2 of Absolute Maximum Ratings (Module 3). Changed all minimum hold times to -0.4 for Global Clock Set-Up and Hold for LVTTL Standard, with DLL (Module 3). Revised maximum T_{DLLPW} in -6 speed grade for DLL Timing Parameters (Module 3).
04/02/2001	1.4	<ul style="list-style-type: none"> In Table 4, FG676 Fine-Pitch BGA — XCV405E, pin B19 is no longer labeled as VREF, and pin G16 is now labeled as VREF. Updated values in Virtex-E Switching Characteristics tables. Converted data sheet to modularized format. See the Virtex-E Extended Memory Data Sheet section.
07/23/2001	1.5	<ul style="list-style-type: none"> Changed definition of T31 and T32 pins in Table 1 for XCV405E and the XCV812E devices.
07/17/2002	1.6	<ul style="list-style-type: none"> Data sheet designation upgraded from Preliminary to Production.
03/21/2014	3.0	<ul style="list-style-type: none"> This product is obsolete/discontinued per XCN12026.

Virtex-E Extended Memory Data Sheet

The Virtex-E Extended Memory Data Sheet contains the following modules:

- DS025-1, Virtex-E 1.8V Extended Memory FPGAs: Introduction and Ordering Information (Module 1)
- DS025-2, Virtex-E 1.8V Extended Memory FPGAs: Functional Description (Module 2)
- DS025-3, Virtex-E 1.8V Extended Memory FPGAs: DC and Switching Characteristics (Module 3)
- DS025-4, Virtex-E 1.8V Extended Memory FPGAs: Pinout Tables (Module 4)

Looking for pricing, stock, or lifecycle information?

Click below to explore more details on WIN SOURCE:

 [View XCV405E-6BG560C on WIN SOURCE](#)

 [Xilinx Inc. Information](#)

Optimize Your Supply Chain with WIN SOURCE Solutions

-  Global Sourcing Solution
-  Obsolete Management
-  Cost Control Management
-  Shortage Management
-  Alternative Solution
-  Excess Inventory Management