



**THE DATASHEET OF  
TPS54361QDPRTQ1**



# TPS54361-Q1 4.5-V to 60-V Input, 3.5-A, Step Down DC-DC Converter with Soft-Start and Eco-mode™

## 1 Features

- Qualified for Automotive Applications
- AEC-Q100 Qualified With the Following Results:
  - Device Temperature Grade 1:  $-40^{\circ}\text{C}$  to  $125^{\circ}\text{C}$  Ambient Operating Temperature Range
  - Device HBM ESD Classification Level H1C
  - Device CDM ESD Classification Level C3B
- High Efficiency at Light Loads with Pulse Skipping Eco-mode™
- 87-m $\Omega$  High-Side MOSFET
- 152- $\mu\text{A}$  Operating Quiescent Current and 2- $\mu\text{A}$  Shutdown Current
- 100-kHz to 2.5-MHz Adjustable Switching Frequency
- Synchronizes to External Clock
- Low Dropout at Light Loads with Integrated BOOT Recharge FET
- Adjustable UVLO Voltage and Hysteresis
- UV and OV Power Good Output
- Adjustable Soft-Start and Sequencing
- 0.8-V 1% Internal Voltage Reference
- 10-Pin WSON with Thermal Pad Package
- $-40^{\circ}\text{C}$  to  $150^{\circ}\text{C}$   $T_j$  Operating Range
- Create a Custom Design using the TPS54361-Q1 with the [WEBENCH® Power Designer](#)

## 2 Applications

- Vehicle Accessories: GPS (see [SLVA412](#)), Entertainment
- USB Dedicated Charging Ports and Battery Chargers (see [SLVA464](#))
- 12-V, 24-V and 48-V Industrial, Automotive and Communications Power Systems

### Simplified Schematic

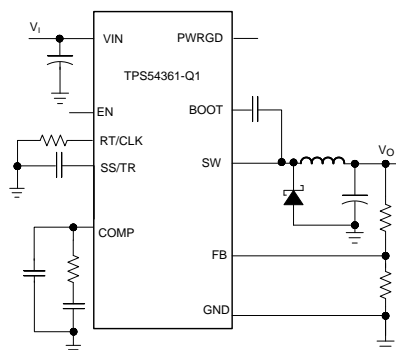

Copyright © 2016, Texas Instruments Incorporated

## 3 Description

The TPS54361-Q1 device is a 60-V, 3.5-A, step down regulator with an integrated high side MOSFET. The device survives load dump pulses up to 65 V per ISO 7637. Current mode control provides simple external compensation and flexible component selection. A low ripple pulse skip mode and supply current of 152- $\mu\text{A}$  enables high efficiency at light loads. Shutdown supply current is reduced to 2  $\mu\text{A}$  when the enable pin is pulled low.

Undervoltage lockout is internally set at 4.3 V but can increase using an external resistor divider at the enable pin. The output voltage startup ramp is controlled by the soft start pin that can also be configured for sequencing/tracking. An open-drain power-good signal indicates the output is within 93% to 106% of the nominal voltage.

A wide adjustable switching-frequency range allows for optimization of either efficiency or external component size. Cycle-by-cycle current-limit, frequency foldback and thermal shutdown protects internal and external components during an overload condition.

The TPS54361-Q1 device is available in a 10-pin 4 mm x 4 mm WSON exposed thermal pad package.

### Device Information<sup>(1)</sup>

DEVICE NAME	PACKAGE	BODY SIZE
TPS54361-Q1	WSON (10)	4.00 mm x 4.00 mm

(1) For all available packages, see the orderable addendum at the end of the data sheet.

### Efficiency vs Load Current

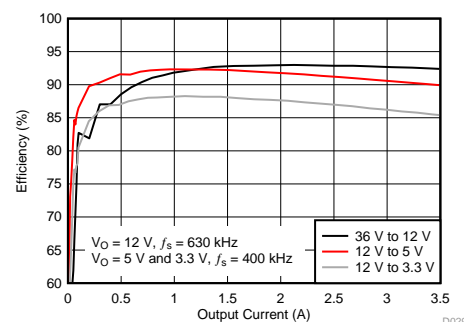

D029



## Table of Contents

<b>1 Features</b> .....	<b>1</b>	7.4 Device Functional Modes.....	<b>28</b>
<b>2 Applications</b> .....	<b>1</b>	<b>8 Application and Implementation</b> .....	<b>30</b>
<b>3 Description</b> .....	<b>1</b>	8.1 Application Information.....	<b>30</b>
<b>4 Revision History</b> .....	<b>2</b>	8.2 Typical Application .....	<b>30</b>
<b>5 Pin Configuration and Functions</b> .....	<b>3</b>	<b>9 Power Supply Recommendations</b> .....	<b>40</b>
<b>6 Specifications</b> .....	<b>4</b>	<b>10 Layout</b> .....	<b>40</b>
6.1 Absolute Maximum Ratings .....	<b>4</b>	10.1 Layout Guidelines .....	<b>40</b>
6.2 ESD Ratings.....	<b>4</b>	10.2 Layout Example .....	<b>42</b>
6.3 Recommended Operating Conditions.....	<b>4</b>	<b>11 Device and Documentation Support</b> .....	<b>43</b>
6.4 Thermal Information .....	<b>5</b>	11.1 Device Support.....	<b>43</b>
6.5 Electrical Characteristics.....	<b>5</b>	11.2 Documentation Support .....	<b>43</b>
6.6 Timing Requirements .....	<b>6</b>	11.3 Receiving Notification of Documentation Updates	<b>43</b>
6.7 Switching Characteristics .....	<b>6</b>	11.4 Community Resources.....	<b>43</b>
6.8 Typical Characteristics .....	<b>7</b>	11.5 Trademarks .....	<b>43</b>
<b>7 Detailed Description</b> .....	<b>12</b>	11.6 Electrostatic Discharge Caution.....	<b>44</b>
7.1 Overview .....	<b>12</b>	11.7 Glossary .....	<b>44</b>
7.2 Functional Block Diagram .....	<b>13</b>	<b>12 Mechanical, Packaging, and Orderable</b>	<b>44</b>
7.3 Feature Description.....	<b>13</b>	<b>Information</b> .....	<b>44</b>

## 4 Revision History

### Changes from Revision A (April 2014) to Revision B

**Page**

• Changed package SON To: WSON in the <i>Features</i> and throughout the data sheet.....	<b>1</b>
• Changed PowerPAD™ To Thermal Pad in the <i>Features</i> and throughout the data sheet .....	<b>1</b>
• Added the WEBENCH information in the <i>Features</i> , <i>Detailed Design Procedure</i> , and <i>Device Support</i> sections .....	<b>1</b>
• Added SW, 5-ns Transient to the <i>Absolute Maximum Ratings</i> .....	<b>4</b>
• Moved Storage temperature to the <i>Absolute Maximum Ratings</i> table .....	<b>4</b>
• Changed the <i>Handling Ratings</i> table to the <i>ESD Ratings</i> table .....	<b>4</b>
• Changed <a href="#">Equation 10</a> and <a href="#">Equation 11</a> .....	<b>20</b>
• Changed <a href="#">Equation 30</a> .....	<b>31</b>

### Changes from Original (April 2014) to Revision A

**Page**

• Changed device status from <i>Product Preview</i> to <i>Production Data</i> .....	<b>1</b>
---	----------

## 5 Pin Configuration and Functions

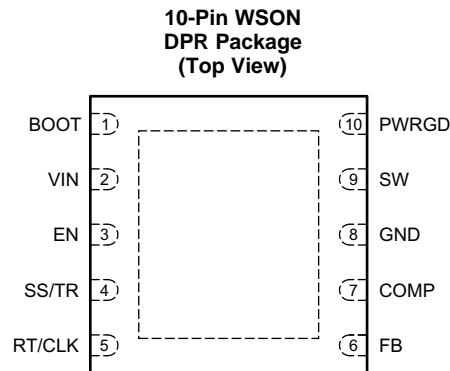

### Pin Functions

PIN		I/O	DESCRIPTION
NAME	NO.		
BOOT	1	O	A bootstrap capacitor is required between BOOT and SW. If the voltage on this capacitor is below the minimum required to operate the high-side MOSFET, the gate drive is switched off until the capacitor is refreshed.
COMP	7	O	This pin is the error amplifier output and input to the output switch current (PWM) comparator. Connect frequency compensation components to this pin.
EN	3	I	This pin is the enable pin, with an internal pullup current source. Pull EN below 1.2 V to disable. Float EN to enable. Adjust the input undervoltage lockout with two resistors. See the <a href="#">Enable and Adjust Undervoltage Lockout</a> section.
FB	6	I	This pin is the Inverting input of the transconductance (gm) error amplifier.
GND	8	–	Ground
VIN	2	I	This pin is the input supply voltage with 4.5-V to 60-V operating range.
PWRGD	10	O	The PWRGD pin is an open drain output that asserts low if the output voltage is out of regulation because of thermal shutdown, dropout, over-voltage, or EN shut down.
RT/CLK	5	I	This pin is the resistor timing and external clock pin. An internal amplifier holds this pin at a fixed voltage when using an external resistor to ground to set the switching frequency. If the pin is pulled above the PLL upper threshold, a mode change occurs and the pin becomes a synchronization input. The internal amplifier is disabled and the pin is a high impedance clock input to the internal PLL. If clocking edges stop, the internal amplifier is re-enabled and the operating mode returns to resistor frequency programming.
SS/TR	4	I	This pin is the soft-start and tracking pin. An external capacitor connected to this pin sets the output rise time. Because the voltage on this pin overrides the internal reference, SS/TR can be used for tracking and sequencing.
SW	9	O	The SW pin is the source of the internal high-side power MOSFET and switching node of the converter.
Thermal Pad		–	The GND pin must be electrically connected to the exposed pad on the printed circuit board for proper operation.

## 6 Specifications

### 6.1 Absolute Maximum Ratings<sup>(1)</sup>

over operating free-air temperature range (unless otherwise noted)

		MIN	MAX	UNIT
Input voltage	VIN	-0.3	65	V
	EN	-0.3	8.4	
	BOOT		73	
	FB	-0.3	3	
	COMP	-0.3	3	
	PWRGD	-0.3	6	
	SS/TR	-0.3	3	
	RT/CLK	-0.3	3.6	
Output voltage	BOOT-SW		8	V
	SW	-0.6	65	
	SW, 5-ns Transient	-7	65	
	SW, 10-ns Transient	-2	65	
Operating junction temperature		-40	150	°C
Storage temperature, T <sub>stg</sub>		-65	150	°C

- (1) Stresses beyond those listed under *absolute maximum ratings* may cause permanent damage to the device. These are stress ratings only and functional operation of the device at these or any other conditions beyond those indicated under *recommended operating conditions* is not implied. Exposure to absolute-maximum-rated conditions for extended periods may affect device reliability.

### 6.2 ESD Ratings

			VALUE	UNIT	
V <sub>(ESD)</sub>	Electrostatic discharge	Human body model (HBM), per AEC Q100-002 <sup>(1)</sup>	±2000	V	
		Charged device model (CDM), per AEC-Q100-011	Corner pins (1, 5, 6, and 10)	±750	V
			Other pins	±500	

- (1) AEC Q100-002 indicates HBM stressing is done in accordance with the ANSI/ESDA/JEDEC JS-001 specification.

### 6.3 Recommended Operating Conditions

over operating free-air temperature range (unless otherwise noted)

		MIN	MAX	UNIT
V <sub>(VIN)</sub>	Supply input voltage	4.5	60	V
V <sub>O</sub>	Output voltage	0.8	58.8	V
I <sub>O</sub>	Output current	0	3.5	A
T <sub>J</sub>	Junction Temperature	-40	150	°C

## 6.4 Thermal Information

THERMAL METRIC <sup>(1)(2)</sup>		TPS54361-Q1	UNIT
		DPS (10 PINS)	
R <sub>θJA</sub>	Junction-to-ambient thermal resistance (standard board)	35.1	°C/W
ψ <sub>JT</sub>	Junction-to-top characterization parameter	0.3	
ψ <sub>JB</sub>	Junction-to-board characterization parameter	12.5	
R <sub>θJctop</sub>	Junction-to-case(top) thermal resistance	34.1	
R <sub>θJcbot</sub>	Junction-to-case(bottom) thermal resistance	2.2	
R <sub>θJB</sub>	Junction-to-board thermal resistance	12.3	

- (1) For more information about traditional and new thermal metrics, see the [Semiconductor and IC Package Thermal Metrics](#) application report.
- (2) Power rating at a specific ambient temperature T<sub>A</sub> must be determined with a junction temperature of 150°C. This is the point where distortion starts to substantially increase. See the power dissipation estimate in the [Power Dissipation Estimate](#) section of this data sheet for more information.

## 6.5 Electrical Characteristics

T<sub>J</sub> = –40°C to 150°C, V<sub>(VIN)</sub> = 4.5 V to 60 V (unless otherwise noted)

PARAMETER	TEST CONDITIONS	MIN	TYP	MAX	UNIT	
<b>SUPPLY VOLTAGE (VIN PIN)</b>						
Operating input voltage		4.5		60	V	
Internal undervoltage lockout threshold	Rising	4.1	4.3	4.48	V	
Internal undervoltage lockout threshold hysteresis			325		mV	
Shutdown supply current	V <sub>(EN)</sub> = 0 V, 25°C, 4.5 V ≤ V <sub>(VIN)</sub> ≤ 60 V		2.25	4.5	μA	
Operating: nonswitching supply current	V <sub>(FB)</sub> = 0.9 V, T <sub>A</sub> = 25°C		152	200		
<b>ENABLE AND UVLO (EN PIN)</b>						
V <sub>(EN)th</sub>	Enable threshold voltage	No voltage hysteresis, rising and falling	1.1	1.2	1.3	V
I <sub>i</sub>	Input current	Enable threshold 50 mV		–4.6		μA
		Enable threshold –50 mV	–0.58	–1.2	–1.8	
I <sub>hys</sub>	Hysteresis current		–2.2	–3.4	–4.5	μA
<b>VOLTAGE REFERENCE</b>						
Voltage reference		0.792	0.8	0.808	V	
<b>HIGH-SIDE MOSFET</b>						
On-resistance	V <sub>(VIN)</sub> = 12 V, V <sub>(BOOT-SW)</sub> = 6 V		87	185	mΩ	
<b>ERROR AMPLIFIER</b>						
Input current			50		nA	
Error amplifier transconductance (gm)	–2 μA < I <sub>(COMP)</sub> < 2 μA, V <sub>(COMP)</sub> = 1 V		350		μMhos	
Error amplifier transconductance (gm) during soft-start	–2 μA < I <sub>(COMP)</sub> < 2 μA, V <sub>(COMP)</sub> = 1 V, V <sub>(FB)</sub> = 0.4 V		77		μMhos	
Error amplifier dc gain	V <sub>(FB)</sub> = 0.8 V		10 000		V/V	
Min unity gain bandwidth			2500		kHz	
Error amplifier source/sink	V <sub>(COMP)</sub> = 1 V, 100-mV overdrive		±30		μA	
COMP to SW current transconductance			12		A/V	
<b>CURRENT-LIMIT</b>						
Current-limit threshold	All VIN and temperatures, open loop <sup>(1)</sup>	4.5	5.5	6.8	A	
	All temperatures, V <sub>(VIN)</sub> = 12 V, open loop <sup>(1)</sup>	4.5	5.5	6.3		
	V <sub>(VIN)</sub> = 12 V, T <sub>A</sub> = 25°C, open loop <sup>(1)</sup>	5.2	5.5	5.9		
<b>THERMAL SHUTDOWN</b>						
Thermal shutdown			176		°C	
Thermal shutdown hysteresis			12		°C	
<b>TIMING RESISTOR AND EXTERNAL CLOCK (RT/CLK PIN)</b>						
RT/CLK high threshold			1.55	2	V	

- (1) Open Loop current limit measured directly at the SW pin and is independent of the inductor value and slope compensation.

## Electrical Characteristics (continued)

 $T_J = -40^{\circ}\text{C}$  to  $150^{\circ}\text{C}$ ,  $V_{(VIN)} = 4.5\text{ V}$  to  $60\text{ V}$  (unless otherwise noted)

PARAMETER		TEST CONDITIONS	MIN	TYP	MAX	UNIT
RT/CLK low threshold			0.5	1.2		V
<b>SOFT START AND TRACKING (SS/TR PIN)</b>						
$I_{SS}$	Charge current	$V_{(SS/TR)} = 0.4\text{ V}$		1.7		$\mu\text{A}$
$V_{SS(ofs)}$	SS/TR-to-FB matching	$V_{(SS/TR)} = 0.4\text{ V}$		42		mV
	SS/TR-to-reference crossover	98% nominal		1.16		V
	SS/TR discharge current (overload)	$V_{(FB)} = 0\text{ V}$ , $V_{(SS/TR)} = 0.4\text{ V}$		354		$\mu\text{A}$
	SS/TR discharge voltage	$V_{(FB)} = 0\text{ V}$		54		mV
<b>POWER GOOD (PWRGD PIN)</b>						
	FB threshold for PWRGD low	FB falling		90%		
	FB threshold for PWRGD high	FB rising		93%		
	FB threshold for PWRGD low	FB rising		108%		
	FB threshold for PWRGD high	FB falling		106%		
	Hysteresis	FB falling		2.5%		
	Output high leakage	$V_{(PWRGD)} = 5.5\text{ V}$ , $T_A = 25^{\circ}\text{C}$		10		nA
	On resistance	$I_{(PWRGD)} = 3\text{ mA}$ , $V_{(FB)} < 0.79\text{ V}$		45		$\Omega$
	Minimum VIN for defined output	$V_{(PWRGD)} < 0.5\text{ V}$ , $I_{(PWRGD)} = 100\text{ }\mu\text{A}$		0.9	2	V

## 6.6 Timing Requirements

		MIN	TYP	MAX	UNIT
<b>RT/CLK</b>					
Minimum CLK input pulse width			15		ns

## 6.7 Switching Characteristics

 $T_J = -40^{\circ}\text{C}$  to  $150^{\circ}\text{C}$ ,  $V_{(VIN)} = 4.5\text{ V}$  to  $60\text{ V}$  (unless otherwise noted)

PARAMETER		TEST CONDITIONS	MIN	TYP	MAX	UNIT
<b>ENABLE AND UVLO (EN PIN)</b>						
Enable to COMP active		$V_{(VIN)} = 12\text{ V}$ , $T_A = 25^{\circ}\text{C}$		540		$\mu\text{s}$
<b>CURRENT-LIMIT</b>						
Current limit threshold delay				60		ns
<b>SW</b>						
$t_{on}$	Minimum on time	$V_{(VIN)} = 23.7\text{ V}$ , $V_O = 5\text{ V}$ , $I_O = 3.5\text{ A}$ , $R_{(RT)} = 39.6\text{ k}\Omega$ , $T_A = 25^{\circ}\text{C}$		100		ns
<b>RT/CLK</b>						
Switching frequency range using RT mode			100		2500	kHz
$f_S$	Switching frequency	$R_{(RT)} = 200\text{ k}\Omega$	450	500	550	kHz
Switching frequency range using CLK mode			160		2300	kHz
<b>TIMING RESISTOR AND EXTERNAL CLOCK (RT/CLK PIN)</b>						
RT/CLK falling edge to SW rising edge delay		Measured at 500 kHz with an RT resistor ( $R_{(RT)}$ ) in series		55		ns
PLL lock in time		Measured at 500 kHz		78		$\mu\text{s}$

## 6.8 Typical Characteristics

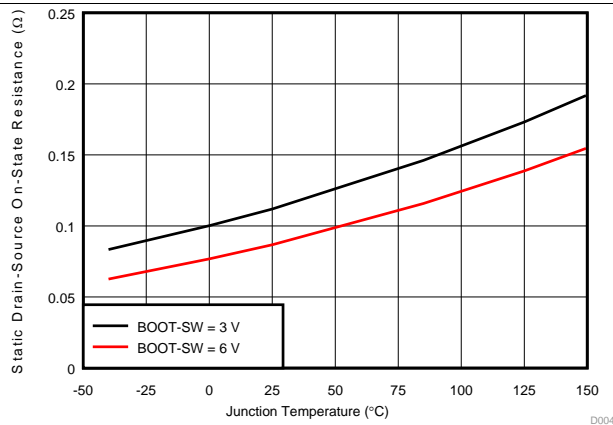

Figure 1. On Resistance vs Junction Temperature

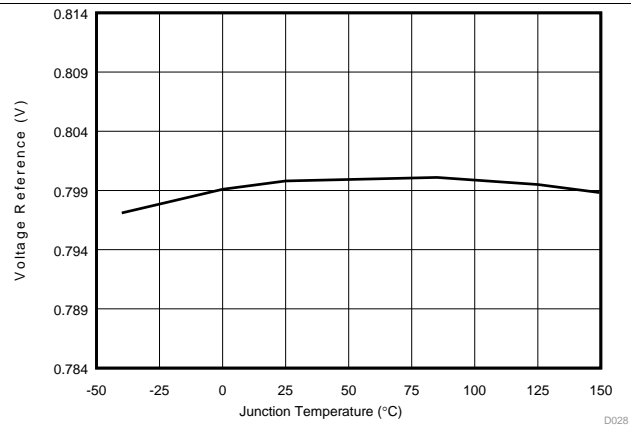

Figure 2. Voltage Reference vs Junction Temperature

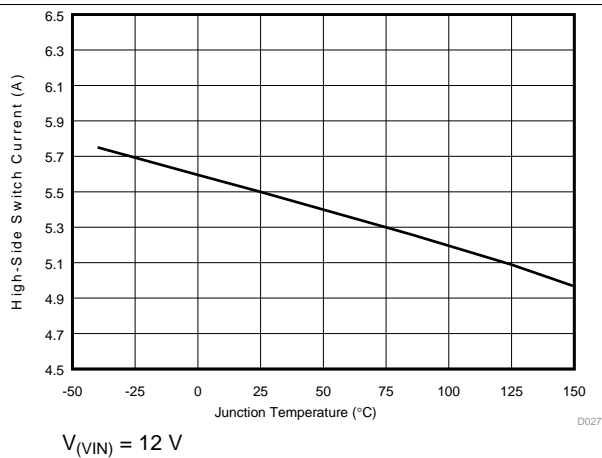

Figure 3. Switch Current-Limit vs Junction Temperature

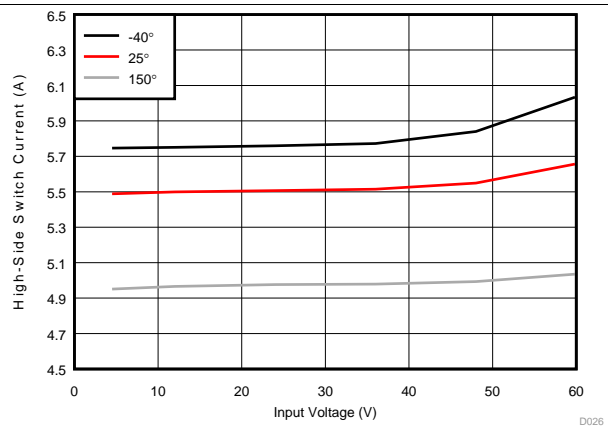

Figure 4. Switch Current-Limit vs Input Voltage

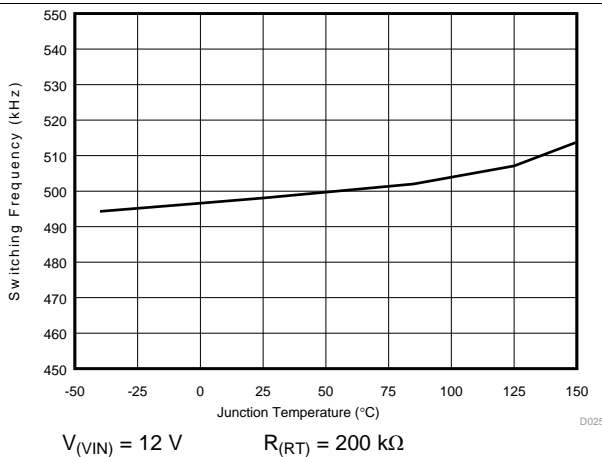

Figure 5. Switching Frequency vs Junction Temperature

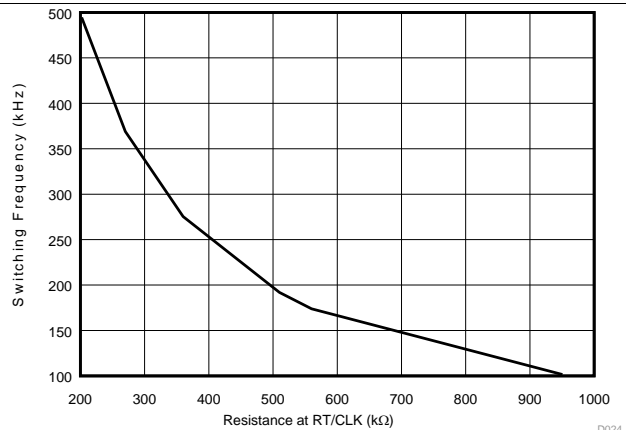
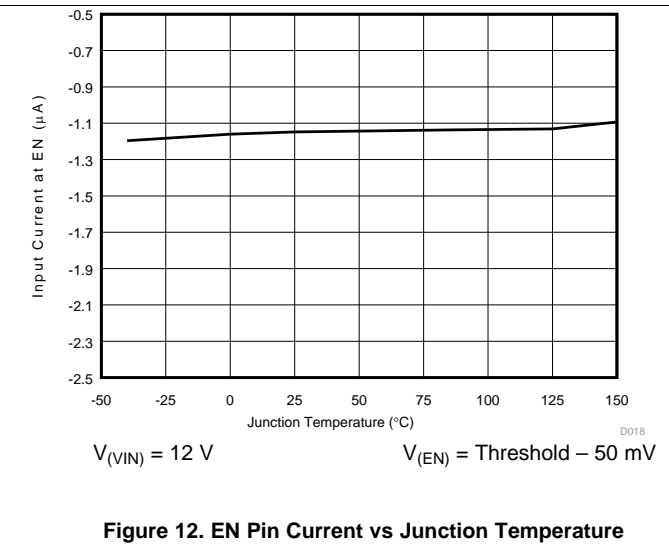
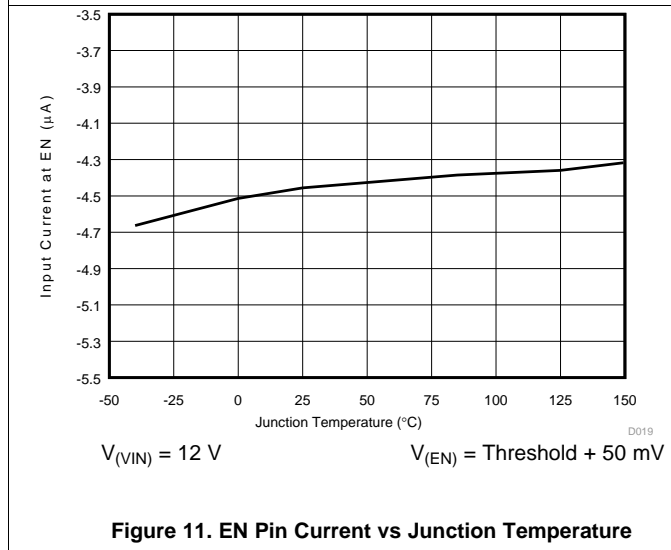
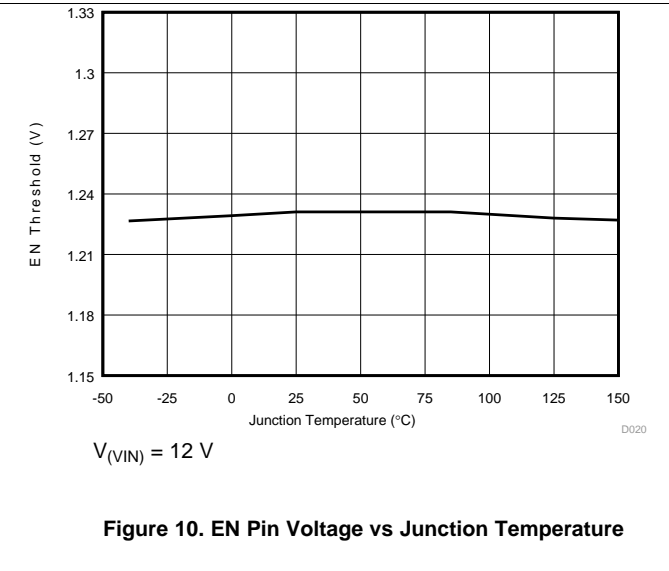
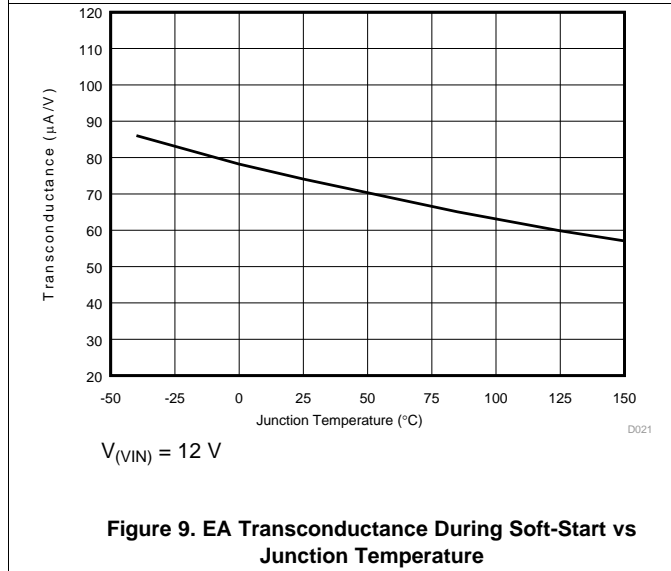
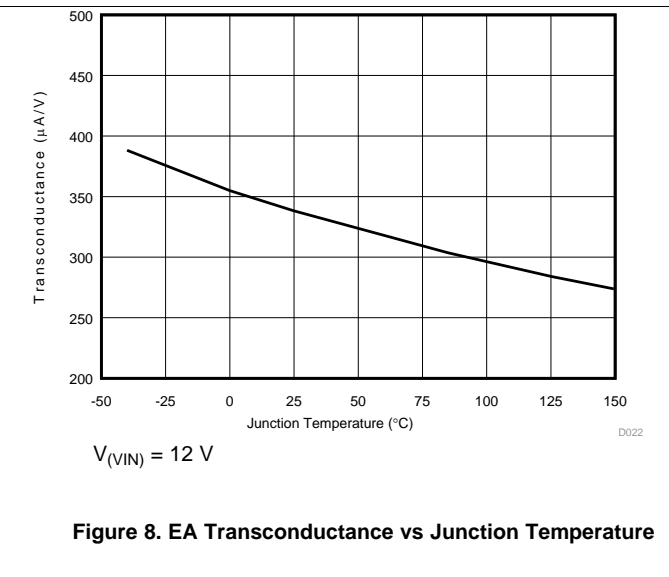
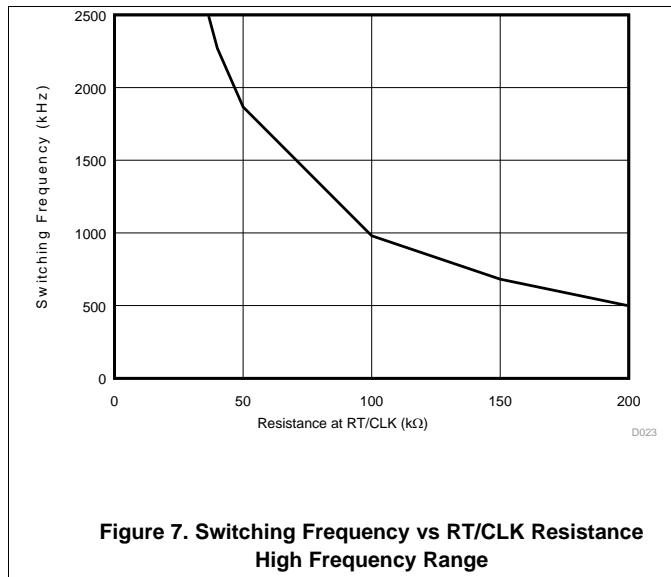
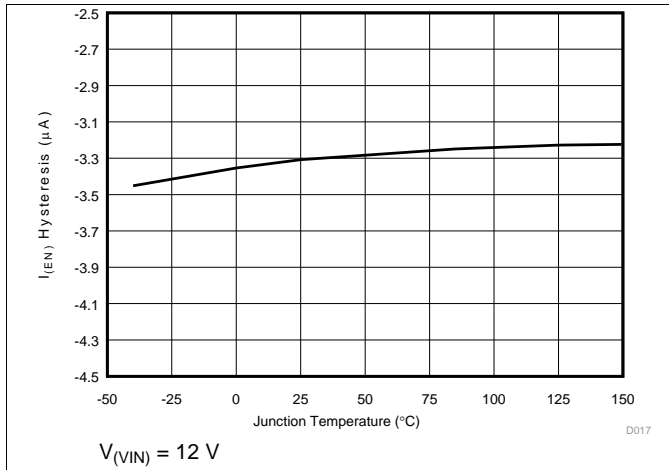

Figure 6. Switching Frequency vs RT/CLK Resistance Low Frequency Range

Typical Characteristics (continued)



**Typical Characteristics (continued)**



**Figure 13. EN Pin Current Hysteresis vs Junction Temperature**

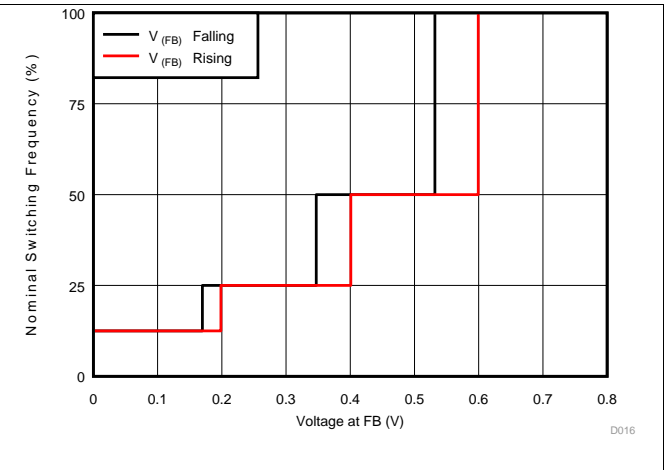

**Figure 14. Switching Frequency vs FB**

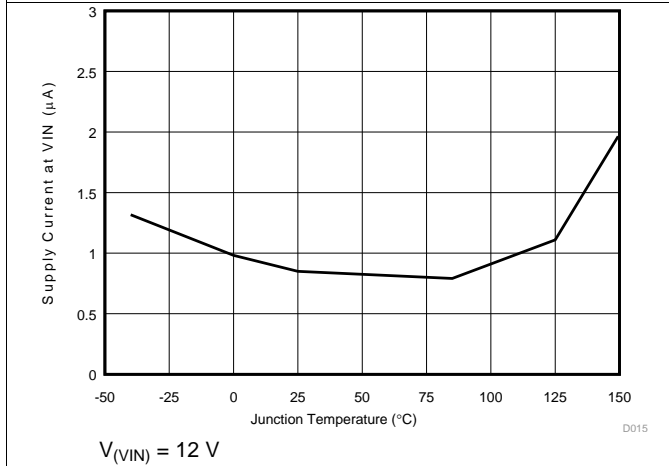

**Figure 15. Shutdown Supply Current vs Junction Temperature**

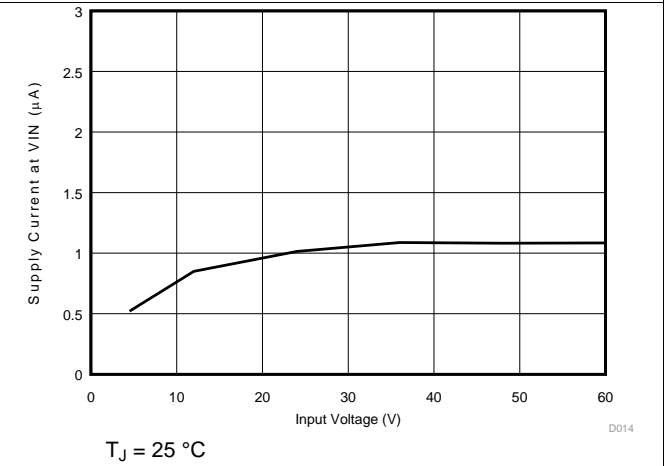

**Figure 16. Shutdown Supply Current vs Input Voltage**

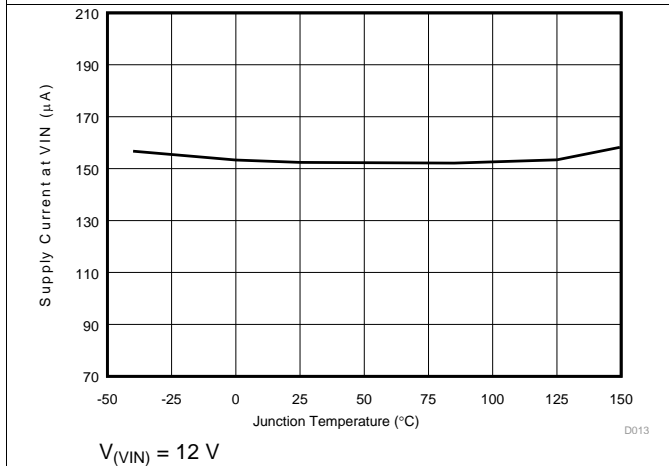

**Figure 17. I<sub>VIN</sub> Supply Current vs Junction Temperature**

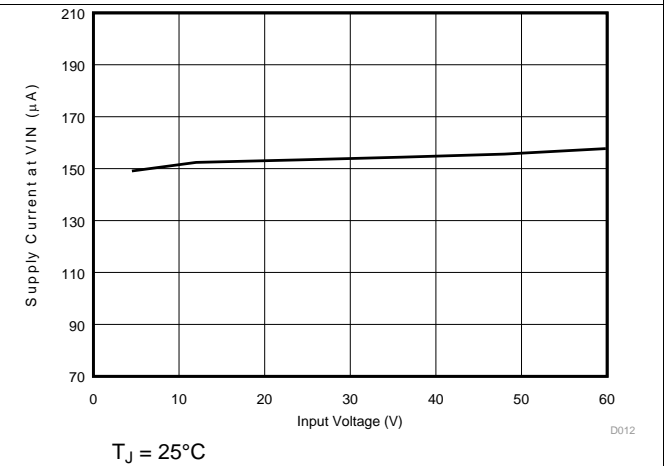

**Figure 18. I<sub>VIN</sub> Supply Current vs Input Voltage**

Typical Characteristics (continued)

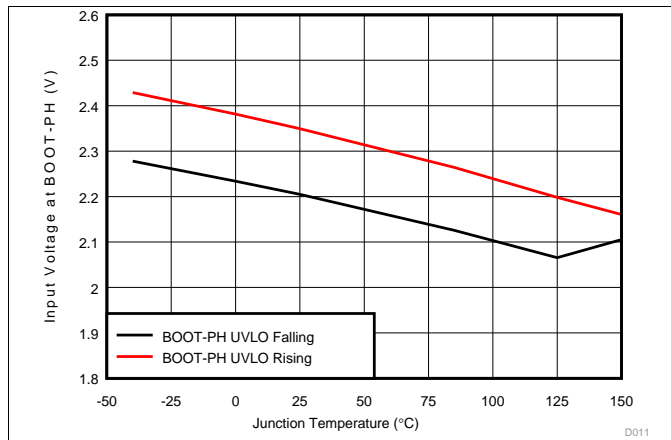

Figure 19. BOOT-SW UVLO vs Junction Temperature

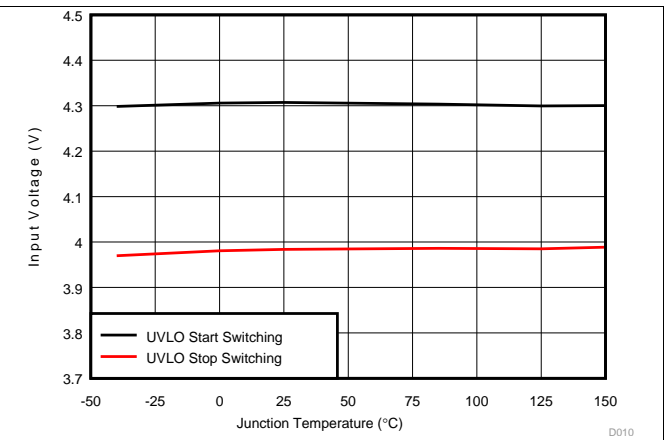

Figure 20. Input Voltage UVLO vs Junction Temperature

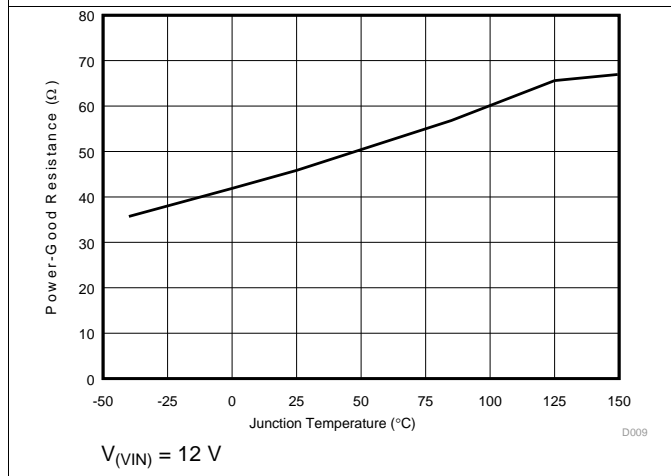

Figure 21. PWRGD On Resistance vs Junction Temperature

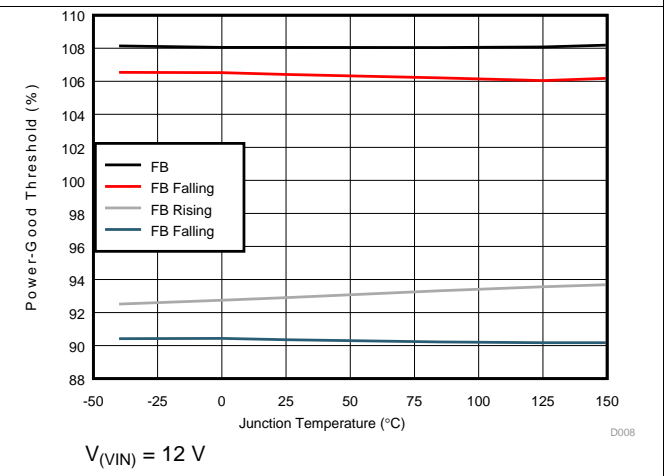

Figure 22. PWRGD Threshold vs Junction Temperature

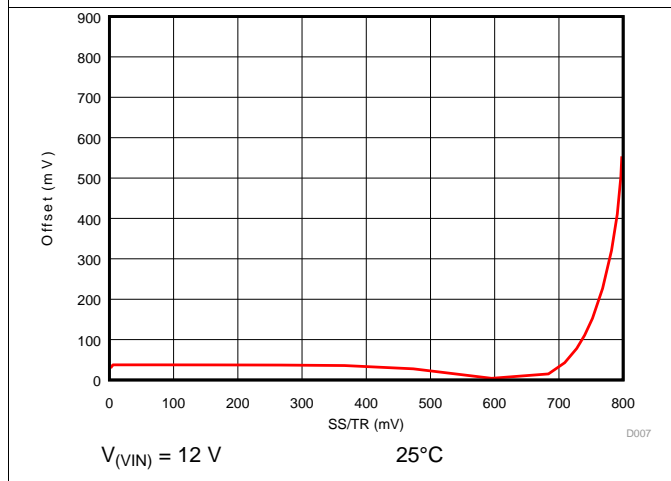

Figure 23. SS/TR to FB Offset vs FB

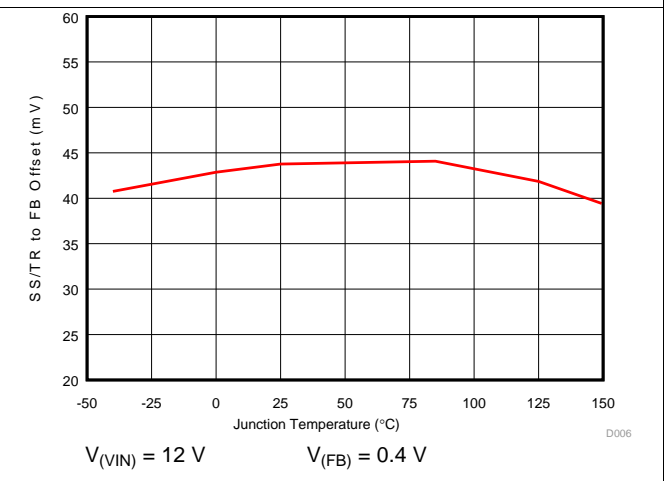

Figure 24. SS/TR to FB Offset vs Temperature

Typical Characteristics (continued)

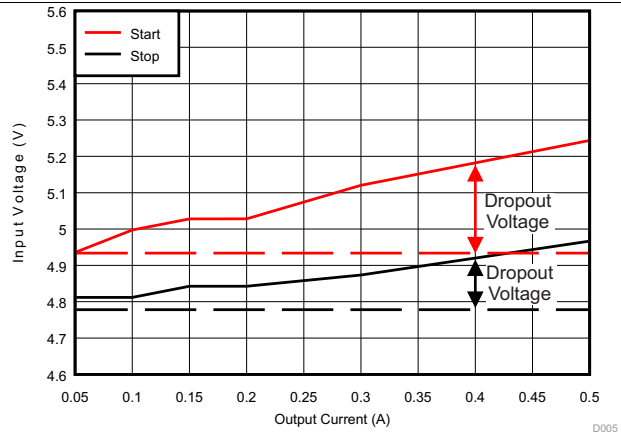

Figure 25. 5-V Start and Stop Voltage (see [Low Dropout Operation and Bootstrap Voltage \(BOOT\)](#))

## 7 Detailed Description

### 7.1 Overview

The TPS54361-Q1 device is a 60-V, 3.5-A, step-down (buck) regulator with an integrated high-side n-channel MOSFET. The device implements constant-frequency current-mode control which reduces output capacitance and simplifies external frequency compensation. The wide switching frequency range of 100 kHz to 2500 kHz allows either efficiency or size optimization when selecting the output filter components. The switching frequency is adjusted using a resistor to ground connected to the RT/CLK pin. The device has an internal phase-locked loop (PLL) connected to the RT/CLK pin that synchronizes the power switch turn-on to a falling edge of an external clock signal.

The TPS54361-Q1 device has a default input start-up voltage of 4.3 V typical. The EN pin adjusts the input voltage undervoltage lockout (UVLO) threshold with two external resistors. An internal pullup current source enables operation when the EN pin is floating. The operating current is 152  $\mu$ A under no load condition when not switching. When the device is disabled, the supply current is 2  $\mu$ A.

The integrated 87-m $\Omega$  high-side MOSFET supports high-efficiency power-supply designs capable of delivering 3.5 A of continuous current to a load. The gate-drive bias voltage for the integrated high-side MOSFET is supplied by a bootstrap capacitor connected from the BOOT to SW pins. The TPS54361-Q1 device reduces the external component count by integrating the bootstrap recharge diode. The BOOT pin capacitor voltage is monitored by a UVLO circuit which turns off the high-side MOSFET when the BOOT to SW voltage falls below a preset threshold. An automatic BOOT capacitor recharge circuit allows the TPS54361-Q1 device to operate at high duty cycles approaching 100%. Therefore, the maximum output voltage is near the minimum input supply voltage of the application. The minimum output voltage is the internal 0.8 V feedback reference.

Output overvoltage transients are minimized by an Overvoltage Protection (OVP) comparator. When the OVP comparator is activated, the high-side MOSFET is turned off and remains off until the output voltage is less than 106% of the desired output voltage.

The SS/TR (soft-start/tracking) pin is used to minimize inrush currents or provide power supply sequencing during power up. A small value capacitor must be connected to the pin to adjust the soft-start time. A resistor divider can be connected to the pin for critical power supply sequencing requirements. The SS/TR pin is discharged before the output powers up. This discharging ensures a repeatable restart after an over-temperature fault, UVLO fault or a disabled condition. When the overload condition is removed, the soft-start circuit controls the recovery from the fault output level to the nominal regulation voltage. A frequency foldback circuit reduces the switching frequency during start up and overcurrent fault conditions to help maintain control of the inductor current.

## 7.2 Functional Block Diagram

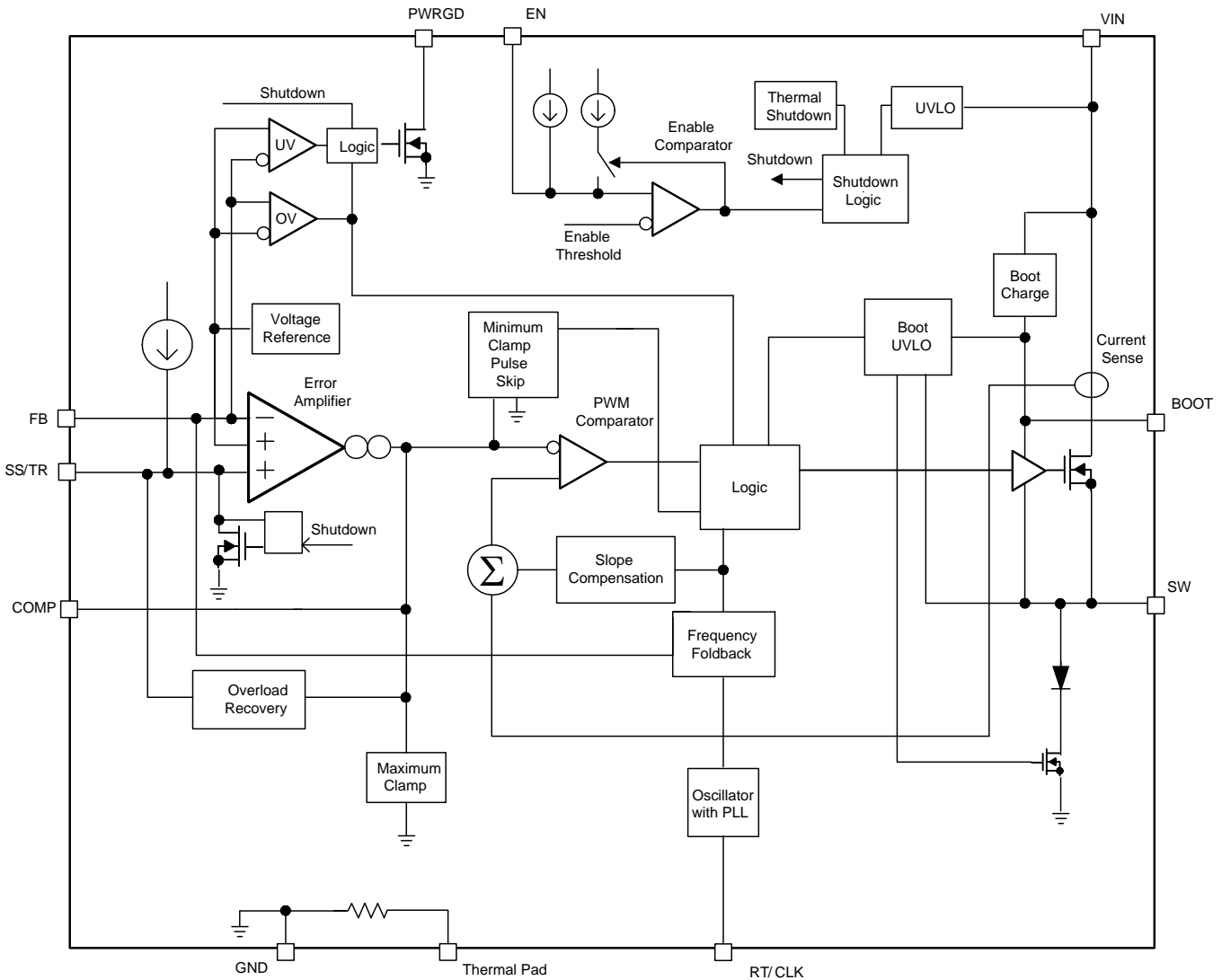

Copyright © 2017, Texas Instruments Incorporated

## 7.3 Feature Description

### 7.3.1 Fixed-Frequency PWM Control

The TPS54361-Q1 device uses fixed-frequency peak current-mode control with adjustable switching frequency. The output voltage is compared through external resistors connected to the FB pin to an internal voltage reference by an error amplifier. An internal oscillator initiates the turn on of the high-side power switch. The error amplifier output at the COMP pin controls the high-side power-switch current. When the high-side MOSFET switch current reaches the threshold level set by the COMP voltage, the power switch is turned off. The COMP pin voltage increases and decreases as the output current increases and decreases. The device implements current-limiting by clamping the COMP pin voltage to a maximum level. The pulse skipping Eco-mode is implemented with a minimum voltage clamp on the COMP pin.

### 7.3.2 Slope Compensation Output Current

The TPS54361-Q1 device adds a compensating ramp to the MOSFET switch-current sense signal. This slope compensation prevents sub-harmonic oscillations at duty cycles greater than 50%. The peak current-limit of the high-side switch is not affected by the slope compensation and remains constant over the full duty-cycle range.

## Feature Description (continued)

### 7.3.3 Pulse-Skip Eco-mode

The TPS54361-Q1 device operates in a pulse-skipping Eco-mode at light load currents to improve efficiency by reducing switching and gate drive losses. The device enters Eco-mode if the output voltage is within regulation and the peak switch current at the end of any switching cycle is below the pulse-skipping current threshold. The pulse-skipping current threshold is the peak switch-current level corresponding to a nominal COMP voltage of 600 mV.

When in Eco-mode, the COMP pin voltage is clamped at 600 mV and the high-side MOSFET is inhibited. Because the device is not switching, the output voltage begins to decay. The voltage control-loop responds to the falling output voltage by increasing the COMP pin voltage. The high-side MOSFET is enabled and switching resumes when the error amplifier lifts COMP above the pulse skipping threshold. The output voltage recovers to the regulated value, and COMP eventually falls below the Eco-mode pulse-skipping threshold at which time the device again enters Eco-mode. The internal PLL remains operational when in Eco-mode. When operating at light load currents in Eco-mode, the switching transitions occur synchronously with the external clock signal.

During Eco-mode operation, the TPS54361-Q1 device senses and controls the peak switch current and not the average load current. Therefore the load current at which the device enters Eco-mode is dependent on the output inductor value. The circuit in [Figure 48](#) enters Eco-mode at about a 25-mA output current. As the load current approaches zero, the device enters a pulse-skip mode. During the time period when there is no switching the input current is reduced to the 152- $\mu$ A quiescent current.

### 7.3.4 Low Dropout Operation and Bootstrap Voltage (BOOT)

The TPS54361-Q1 device provides an integrated bootstrap voltage-regulator. A small capacitor between the BOOT and SW pins provides the gate-drive voltage for the high-side MOSFET. The BOOT capacitor is refreshed when the high-side MOSFET is off and the external low-side diode conducts. The recommended value of the BOOT capacitor is 0.1  $\mu$ F. A ceramic capacitor with an X7R or X5R-grade dielectric with a voltage rating of 10 V or higher is recommended for stable performance over temperature and voltage.

When operating with a low voltage difference from input to output, the high-side MOSFET of the TPS54361-Q1 device operates at a 100% duty cycle as long as the BOOT to SW pin voltage is greater than 2.1 V. When the voltage from BOOT to SW drops below 2.1 V, the high-side MOSFET turns off and an integrated low-side MOSFET pulls SW low to recharge the BOOT capacitor. To reduce the losses of the small low-side MOSFET at high output voltages, the small low-side MOSFET disables at 24-V output and re-enables when the output reaches 21.5 V.

Because the gate-drive current sourced from the BOOT capacitor is small, the high-side MOSFET can remain on for many switching cycles before the MOSFET is turned off to refresh the capacitor. Thus the effective duty cycle of the switching regulator can be high, approaching 100%. The effective duty cycle of the converter during dropout is mainly influenced by the voltage drops across the power MOSFET, the inductor resistance, the low-side diode voltage and the printed circuit board (PCB) resistance.

The start and stop voltage for a typical 5-V output application is shown in [Figure 25](#) where the input voltage is plotted versus load current. The start voltage is defined as the input voltage required to regulate the output within 1% of nominal. The stop voltage is defined as the input voltage at which the output drops by 5% or where switching stops.

During high duty-cycle (low-dropout) conditions, inductor current ripple increases when the BOOT capacitor is being recharged which results in an increase in output voltage ripple. Increased ripple occurs when the off time required to recharge the BOOT capacitor is longer than the high-side off time associated with cycle-by-cycle PWM control.

## Feature Description (continued)

At heavy loads, the minimum input voltage must be increased to ensure a monotonic startup. Equation 1 calculates the minimum input voltage for this condition.

$$V_{Omax} = D_{max} \times (V_{(VIN)min} - I_{Omax} \times r_{DS(on)} + V_d) - V_d + I_{Omax} \times R_{DC}$$

where

- $D_{max} \geq 0.9$
  - $r_{DS(on)} = 1 / (-0.3 \times V_{(BOOT\_SW)}^2 + 3.577 \times V_{(BOOT\_SW)} - 4.246)$
  - $I_{(BOOT\_SW)} = 100 \mu A$
  - $V_{(BOOT\_SW)} = V_{(BOOT)} + V_d$
  - $V_{(BOOT)} = (1.41 \times V_{(VIN)} - 0.554 - V_d \times f_s \times 10^{-6} - 1.847 \times 10^3 \times I_{(BOOT\_SW)}) / (1.41 + f_s \times 10^{-6})$
  - $V_d =$  Forward Drop of the Catch Diode
- (1)

### 7.3.5 Error Amplifier

The TPS54361-Q1 voltage-regulation loop is controlled by a transconductance error amplifier. The error amplifier compares the FB pin voltage to the lower of the internal soft-start voltage or the internal 0.8-V voltage reference. The transconductance (gm) of the error amplifier is 350  $\mu A/V$  during normal operation. During soft-start operation, the transconductance is reduced to 78  $\mu A/V$  and the error amplifier is referenced to the internal soft-start voltage.

The frequency compensation components (capacitor, series resistor, and capacitor) are connected between the error amplifier output COMP pin and GND pin.

### 7.3.6 Adjusting the Output Voltage

The internal voltage reference produces a precise 0.8-V  $\pm 1\%$  voltage reference over the operating temperature and voltage range by scaling the output of a bandgap reference circuit. The output voltage is set by a resistor divider from the output node to the FB pin. Divider resistors with a 1%-tolerance or better are recommended. Select the low-side resistor  $R_{LS}$  for the desired divider current and use Equation 2 to calculate  $R_{HS}$ . To improve efficiency at light loads consider using larger value resistors. However, if the values are too high, the regulator is more susceptible to noise and voltage errors from the FB input current may become noticeable.

$$R_{(HS)} = R_{(LS)} \times \left( \frac{V_O - 0.8 V}{0.8 V} \right)$$
(2)

### 7.3.7 Enable and Adjust Undervoltage Lockout

The TPS54361-Q1 device enables when the VIN pin voltage rises above 4.3 V and the EN pin voltage exceeds the enable threshold of 1.2 V. The TPS54361-Q1 device disables when the VIN pin voltage falls below 4 V or when the EN pin voltage is below 1.2 V. The EN pin has an internal pullup current source, I1, of 1.2  $\mu A$  that enables operation of the TPS54361-Q1 device when the EN pin floats.

If an application requires a higher undervoltage-lockout (UVLO) threshold, use the circuit shown in Figure 26 to adjust the input voltage UVLO with two external resistors. When the EN pin voltage exceeds 1.2 V, an additional 3.4  $\mu A$  of hysteresis current,  $I_{hys}$ , is sourced out of the EN pin. When the EN pin is pulled below 1.2 V, the 3.-  $\mu A$   $I_{hys}$  current is removed. This additional current facilitates the adjustable input-voltage UVLO hysteresis. Use Equation 3 to calculate  $R_{UVLO1}$  for the desired UVLO hysteresis voltage. Use Equation 4 to calculate  $R_{UVLO2}$  for the desired VIN start voltage.

$$R_{UVLO1} = \frac{V_{START} - V_{STOP}}{I_{hys}}$$
(3)

$$R_{UVLO2} = \frac{V_{(EN)th}}{\frac{V_{START} - V_{(EN)th}}{R_{UVLO1}} + I1}$$
(4)

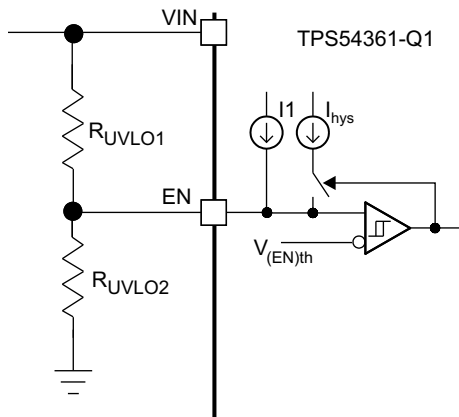
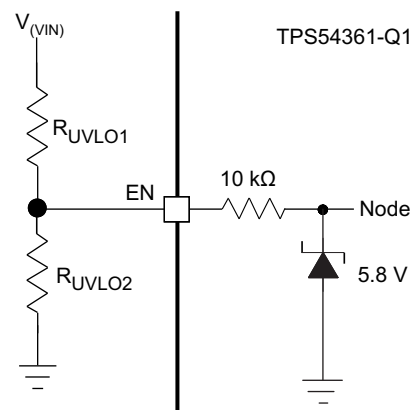
**Feature Description (continued)**

**Figure 26. Adjustable Undervoltage Lockout (UVLO)**

**Figure 27. Internal EN Pin Clamp**
**7.3.8 Soft-Start/Tracking Pin (SS/TR)**

The TPS54361-Q1 device effectively uses the lower voltage of the internal voltage reference or the SS/TR pin voltage as the reference voltage of the power-supply and regulates the output accordingly. A capacitor on the SS/TR pin to ground implements a soft-start time. The TPS54361-Q1 has an internal pullup current source of 1.7  $\mu\text{A}$  that charges the external soft-start capacitor. The calculations for the soft-start time (10% to 90%) are shown in [Equation 5](#). The voltage reference ( $V_{\text{ref}}$ ) is 0.8 V and the soft-start current ( $I_{\text{SS}}$ ) is 1.7  $\mu\text{A}$ . The soft-start capacitor must remain lower than 0.47  $\mu\text{F}$  and greater than 0.47 nF.

$$C_{\text{SS}} \text{ (nF)} = \frac{t_{\text{SS}} \text{ (ms)} \times I_{\text{SS}} \text{ (\mu A)}}{V_{\text{ref}} \text{ (V)} \times 0.8} \quad (5)$$

At power up, the TPS54361-Q1 device does not start switching until the soft-start pin is discharged to less than 54 mV to ensure a proper power up, see [Figure 28](#).

Also, during normal operation, the TPS54361-Q1 device stops switching and the SS/TR must discharge to 54 mV when one of the following occurs: the VIN UVLO is exceeded, the EN pin pulled below 1.2 V, or a thermal shutdown event occurs.

The FB voltage follows the SS/TR pin voltage with a 42 mV offset up to 85% of the internal voltage reference. When the SS/TR voltage is greater than 85% on the internal reference voltage the offset increases as the effective system reference transitions from the SS/TR voltage to the internal voltage reference (see [Figure 23](#)). The SS/TR voltage ramps linearly until clamped at 2.7 V typically as shown in [Figure 28](#).

Feature Description (continued)

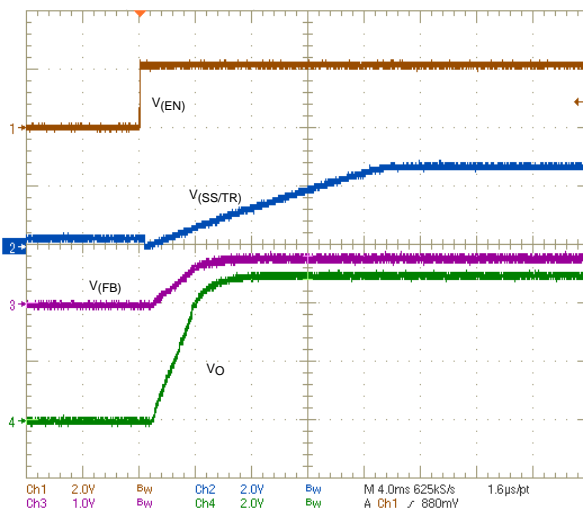

Figure 28. Operation of SS/TR Pin When Starting

7.3.9 Sequencing

Many of the common power supply sequencing methods can be implemented using the SS/TR, EN and PWRGD pins. The sequential method can be implemented using an open drain output of a power on reset pin of another device. The sequential method is illustrated in Figure 29 using two TPS54361-Q1 devices. The power good is connected to the EN pin on the TPS54361-Q1 which enables the second power supply once the primary supply reaches regulation. If needed, a 1-nF ceramic capacitor on the EN pin of the second power supply provides a 1-ms start-up delay. Figure 30 shows the results of Figure 29.

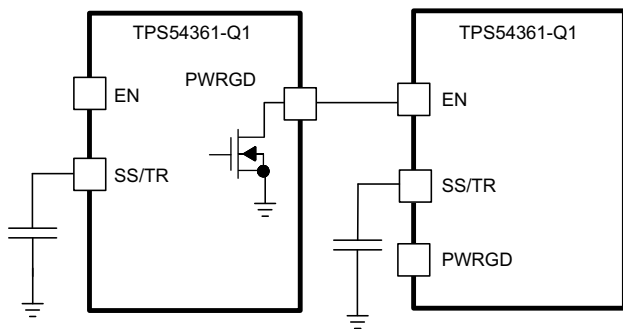

Figure 29. Schematic for Sequential Start-Up Sequence

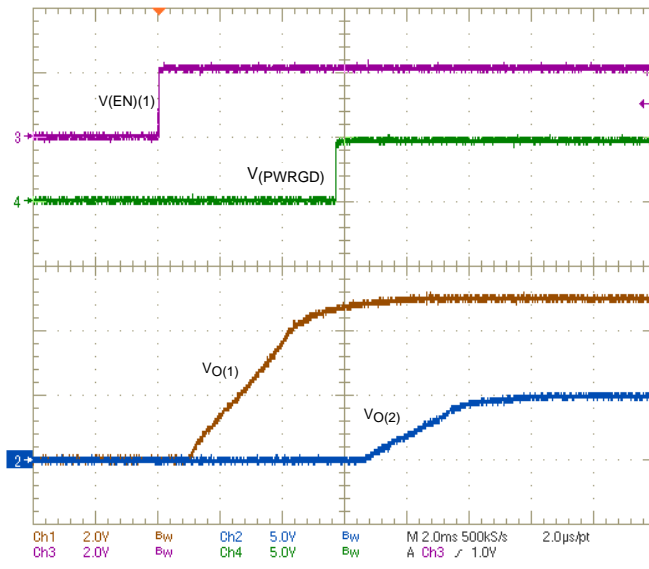
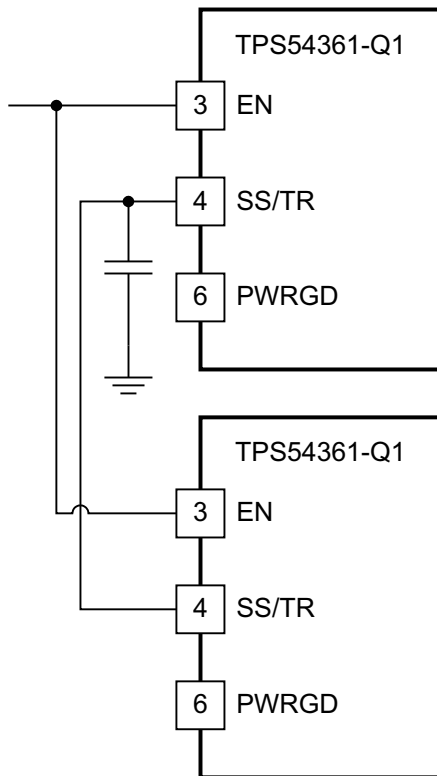

Figure 30. Sequential Startup using EN and PWRGD

Feature Description (continued)



Copyright © 2016, Texas Instruments Incorporated

Figure 31. Schematic for Ratio-metric Start-Up Sequence

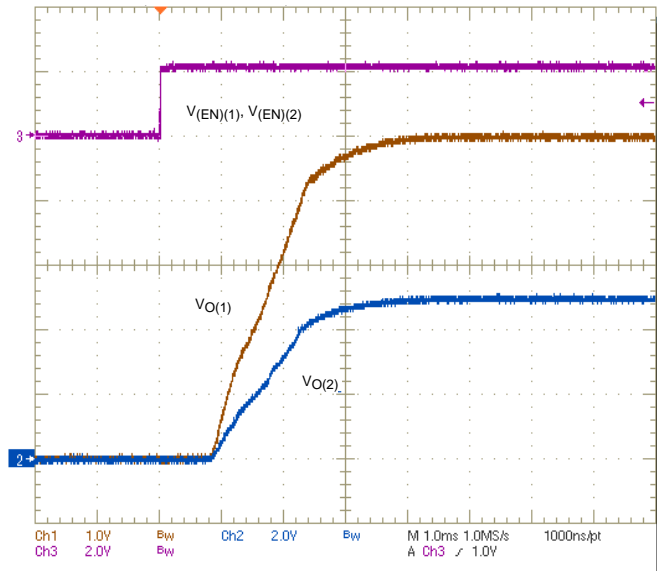
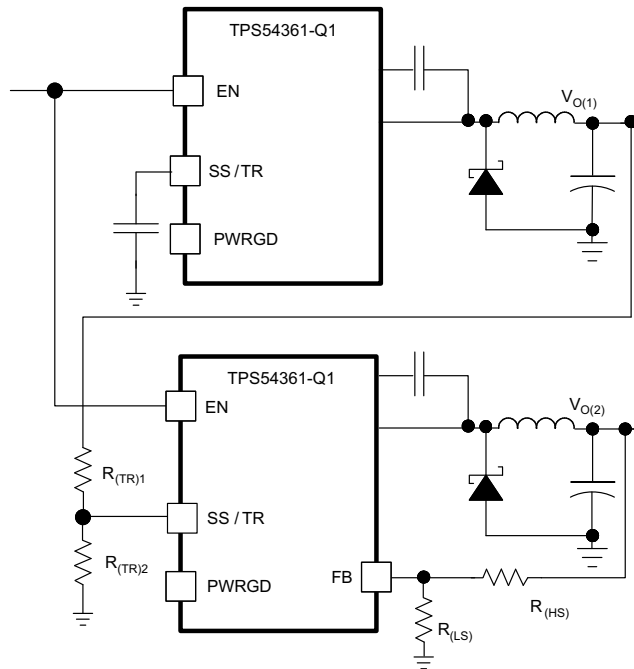

Figure 32. Ratio-Metric Startup Using Coupled SS/TR pins

Figure 31 shows a method for ratio-metric start up sequence by connecting the SS/TR pins together. The regulator outputs ramps up and reaches regulation at the same time. When calculating the soft-start time the pullup current source must be doubled in Equation 5. Figure 32 shows the results of Figure 31.

Feature Description (continued)



Copyright © 2016, Texas Instruments Incorporated

Figure 33. Schematic for Ratiometric and Simultaneous Start-Up Sequence

Ratio-metric and simultaneous power supply sequencing can be implemented by connecting the resistor network of  $R_{(TR)1}$  and  $R_{(TR)2}$  shown in Figure 33 to the output of the power supply that needs to be tracked or another voltage reference source. Using Equation 6 and Equation 7, the tracking resistors can be calculated to initiate the  $V_{O(2)}$  slightly before, after or at the same time as  $V_{O(1)}$ . Equation 8 is the voltage difference between  $V_{O(1)}$  and  $V_{O(2)}$  at the 95% of nominal output regulation.

The  $\Delta V$  variable is 0 V for simultaneous sequencing. To minimize the effect of the inherent SS/TR to FB offset ( $V_{SS(ofs)}$ ) in the soft-start circuit and the offset created by the pullup current source ( $I_{SS}$ ) and tracking resistors, the  $V_{SS(ofs)}$  and  $I_{SS}$  are included as variables in the equations.

To design a ratio-metric start up in which the  $V_{O(2)}$  voltage is slightly greater than the  $V_{O(1)}$  voltage when  $V_{O(2)}$  reaches regulation, use a negative number in Equation 6 through Equation 8 for  $\Delta V$ . Equation 8 results in a positive number for applications which the  $V_{O(2)}$  is slightly lower than  $V_{O(1)}$  when  $V_{O(2)}$  regulation is achieved.

Because the SS/TR pin must be pulled below 54 mV before starting after an EN, UVLO or thermal shutdown fault, careful selection of the tracking resistors is needed to ensure the device restarts after a fault. Make sure the calculated  $R_{(TR)1}$  value from Equation 6 is greater than the value calculated in Equation 9 to ensure the device can recover from a fault.

As the SS/TR voltage becomes more than 85% of the nominal reference voltage the  $V_{SS(ofs)}$  becomes larger as the soft-start circuits gradually handoff the regulation reference to the internal voltage reference. The SS/TR pin voltage must be greater than 1.5 V for a complete handoff to the internal voltage reference as shown in Figure 23.

$$R_{(TR)1} = \frac{V_{O(2)} + \Delta V}{V_{ref}} \times \frac{V_{SS(ofs)}}{I_{SS}} \tag{6}$$

$$R_{(TR)2} = \frac{V_{ref} \times R_{(TR)1}}{V_{O(2)} + \Delta V - V_{ref}} \tag{7}$$

$$\Delta V = V_{O(1)} - V_{O(2)} \tag{8}$$

$$R_{(TR)1} > 2800 \times V_{O(1)} - 180 \times \Delta V \tag{9}$$

Feature Description (continued)

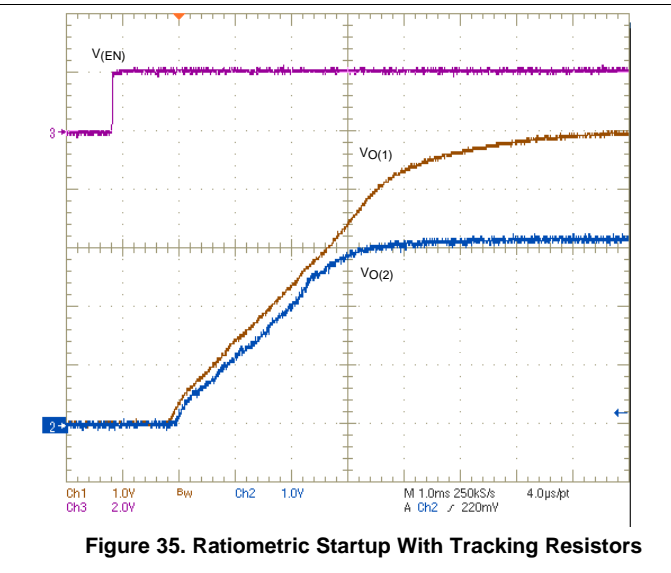
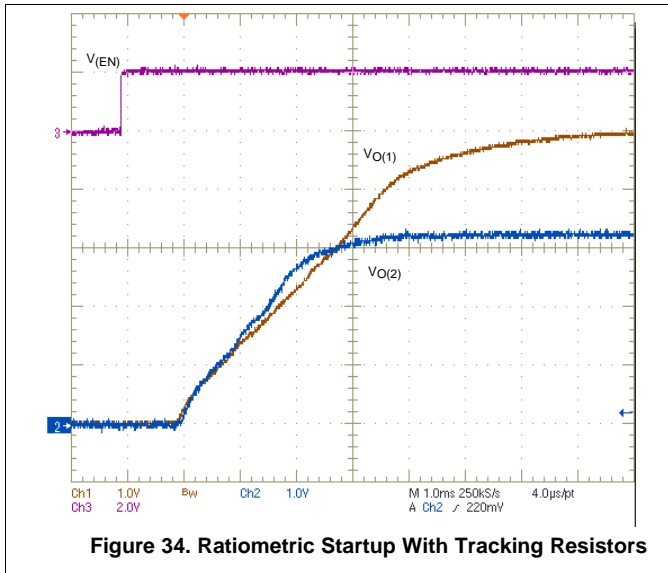

Figure 34. Ratiometric Startup With Tracking Resistors

Figure 35. Ratiometric Startup With Tracking Resistors

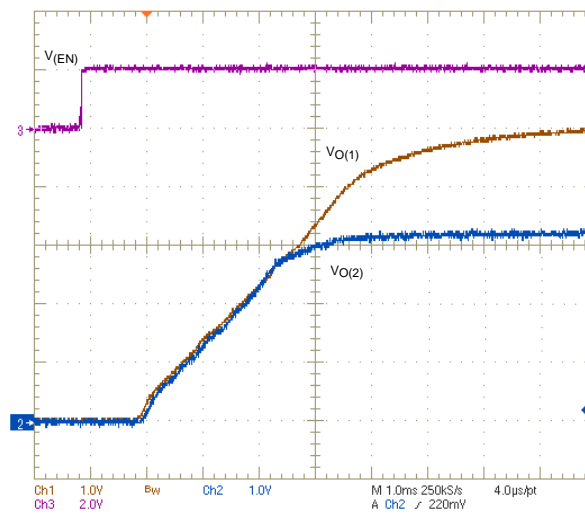

Figure 36. Simultaneous Startup With Tracking Resistor

7.3.10 Constant Switching Frequency and Timing Resistor (RT/CLK) Pin)

The switching frequency of the TPS54361-Q1 is adjustable over a wide range from 100 kHz to 2500 kHz by placing a resistor between the RT/CLK pin and GND pin. The RT/CLK pin voltage is typically 0.5 V and must have a resistor to ground to set the switching frequency. To determine the timing resistance for a given switching frequency, use Equation 10 or Equation 11 or the curves in Figure 5 and Figure 6. To reduce the solution size one would typically set the switching frequency as high as possible, but tradeoffs of the conversion efficiency, maximum input voltage and minimum controllable on time must be considered. The minimum controllable on time is typically 100 ns which limits the maximum operating frequency in applications with high input to output step down ratios. The maximum switching frequency is also limited by the frequency foldback circuit. A more detailed discussion of the maximum switching frequency is provided in the next section.

$$R_T \text{ (k}\Omega\text{)} = \frac{101756}{f_{sw} \text{ (kHz)}^{1.008}} \tag{10}$$

$$f_{sw} \text{ (kHz)} = \frac{92417}{R_T \text{ (k}\Omega\text{)}^{0.991}} \tag{11}$$

## Feature Description (continued)

### 7.3.11 Accurate Current-Limit Operation and Maximum Switching Frequency

The TPS54361-Q1 implements peak current mode control in which the COMP pin voltage controls the peak current of the high-side MOSFET. A signal proportional to the high-side switch current and the COMP pin voltage are compared each cycle. When the peak switch current intersects the COMP control voltage, the high-side switch is turned off. During overcurrent conditions that pull the output voltage low, the error amplifier increases switch current by driving the COMP pin high. The error amplifier output is clamped internally at a level which sets the peak switch current-limit. The TPS54361-Q1 provides an accurate current-limit threshold with a typical current-limit delay of 60 ns. With smaller inductor values, the delay results in a higher peak inductor current. The relationship between the inductor value and the peak inductor current is shown in [Figure 37](#).

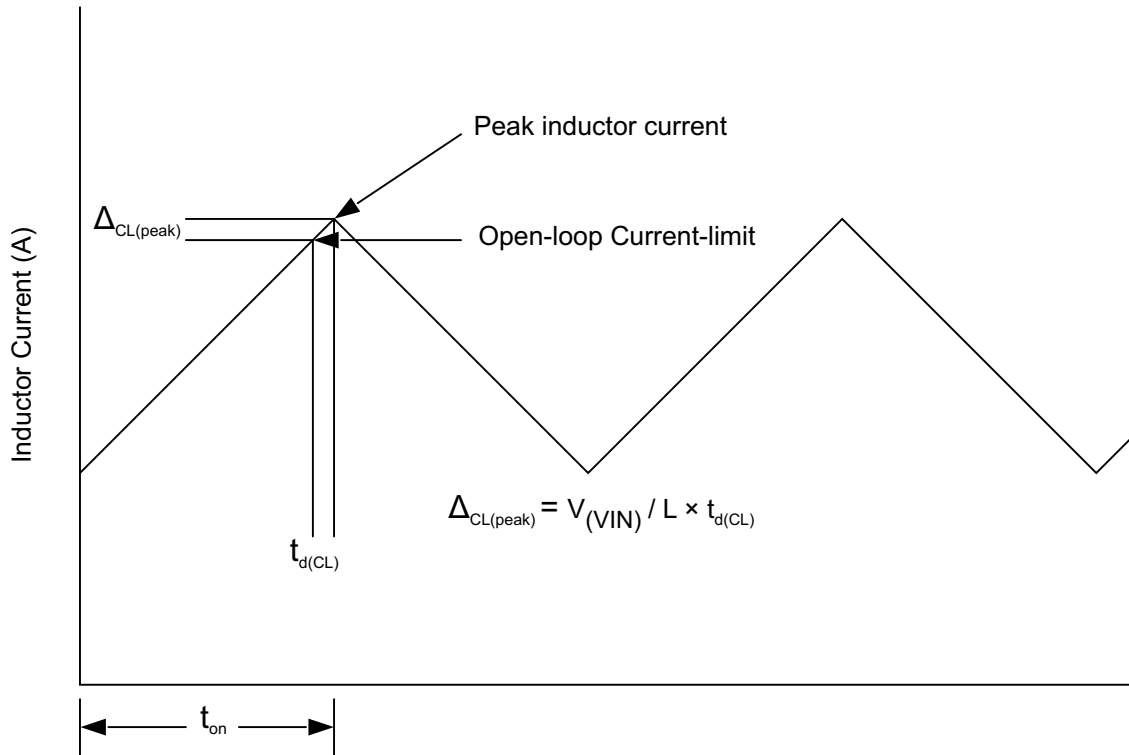

**Figure 37. Current Limit Delay**

To protect the converter in overload conditions at higher switching frequencies and input voltages, the TPS54361-Q1 implements a frequency foldback. The oscillator frequency is divided by 1, 2, 4, and 8 as the FB pin voltage falls from 0.8 V to 0 V. The TPS54361-Q1 device uses a digital frequency foldback to enable synchronization to an external clock during normal start-up and fault conditions. During short-circuit events, the inductor current may exceed the peak current limit because of the high input voltage and the minimum controllable on time. When the output voltage is forced low by the shorted load, the inductor current decreases slowly during the switch off time. The frequency foldback effectively increases the off time by increasing the period of the switching cycle providing more time for the inductor current to ramp down.

With a maximum frequency foldback ratio of 8, there is a maximum frequency at which the inductor current can be controlled by frequency foldback protection. [Equation 12](#) calculates the maximum switching frequency at which the inductor current remains under control when  $V_O$  is forced to  $V_{O(SC)}$ . The selected operating frequency must not exceed the calculated value.

[Equation 13](#) calculates the maximum switching frequency limitation set by the minimum controllable on time and the input to output step down ratio. Setting the switching frequency above this value causes the regulator to skip switching pulses to achieve the low duty cycle required to regulate the output at maximum input voltage.

**Feature Description (continued)**

$$f_{S(\text{skip})\text{max}} = \frac{1}{t_{\text{on}}} \times \left( \frac{I_{\text{O}} \times R_{\text{DC}} + V_{\text{O}} + V_{\text{d}}}{V_{(\text{VIN})\text{max}} - I_{\text{O}} \times r_{\text{DS(on)}} + V_{\text{d}}} \right)$$

where

- $t_{\text{on}}$  = controllable on time
- $I_{\text{O}}$  = output current
- $R_{\text{DC}}$  = inductor resistance
- $V_{(\text{VIN})\text{max}}$  = maximum input voltage
- $V_{\text{O}}$  = output voltage
- $V_{\text{d}}$  = diode voltage drop

(12)

$$f_{S(\text{shift})} = \frac{f_{\text{div}}}{t_{\text{on}}} \times \left( \frac{I_{\text{CL}} \times R_{\text{DC}} + V_{\text{O(SC)}} + V_{\text{d}}}{V_{(\text{VIN})} - I_{\text{CL}} \times r_{\text{DS(on)}} + V_{\text{d}}} \right)$$

where

- $f_{\text{div}}$  = frequency divide equals (1, 2, 4, or 8)
- $V_{\text{O(SC)}}$  = output voltage during short
- $I_{\text{CL}}$  = current limit
- $r_{\text{DS(on)}}$  = switch on resistance

(13)

**7.3.12 Synchronization to RT/CLK Pin**

The RT/CLK pin can receive a frequency synchronization signal from an external system clock. To implement this synchronization feature connect a square wave to the RT/CLK pin through either circuit network shown in [Figure 38](#). The square wave applied to the RT/CLK pin must switch lower than 0.5 V and higher than 2 V and have a pulse width greater than 15 ns. The synchronization frequency range is 160 kHz to 2300 kHz. The rising edge of the SW is synchronized to the falling edge of RT/CLK pin signal. The external synchronization circuit must be designed such that the default frequency set resistor is connected from the RT/CLK pin to ground when the synchronization signal is off. When using a low impedance signal source, the frequency set resistor is connected in parallel with an ac coupling capacitor to a termination resistor (for example, 50  $\Omega$ ) as shown in [Figure 38](#). The two resistors in series provide the default frequency setting resistance when the signal source is turned off. The sum of the resistance must set the switching frequency close to the external CLK frequency. AC coupling the synchronization signal through a 10 pF ceramic capacitor to RT/CLK pin is recommended.

The first time the RT/CLK is pulled above the PLL threshold the TPS54361-Q1 switches from the RT resistor free-running frequency mode to the PLL synchronized mode. The internal 0.5 V voltage source is removed and the RT/CLK pin becomes high impedance as the PLL starts to lock onto the external signal. The switching frequency can be higher or lower than the frequency set with the RT/CLK resistor. The device transitions from the resistor mode to the PLL mode and locks onto the external clock frequency within 78 ms. During the transition from the PLL mode to the resistor programmed mode, the switching frequency falls to 150 kHz and then increases or decreases to the resistor programmed frequency when the 0.5 V bias voltage is reapplied to the RT/CLK resistor.

The switching frequency is divided by 8, 4, 2, and 1 as the FB pin voltage ramps from 0 to 0.8 V. The device implements a digital frequency foldback to enable synchronizing to an external clock during normal start-up and fault conditions. [Figure 39](#), [Figure 40](#) and [Figure 41](#) show the device synchronized to an external system clock in continuous conduction mode (CCM), discontinuous conduction (DCM), and pulse skip mode (Eco-Mode).

Feature Description (continued)

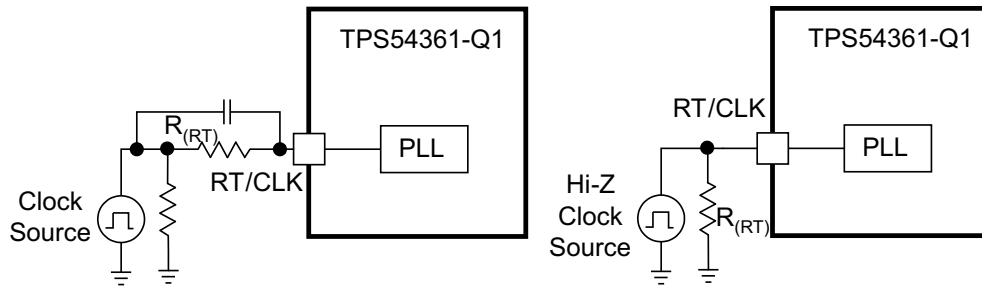

Figure 38. Synchronizing to a System Clock

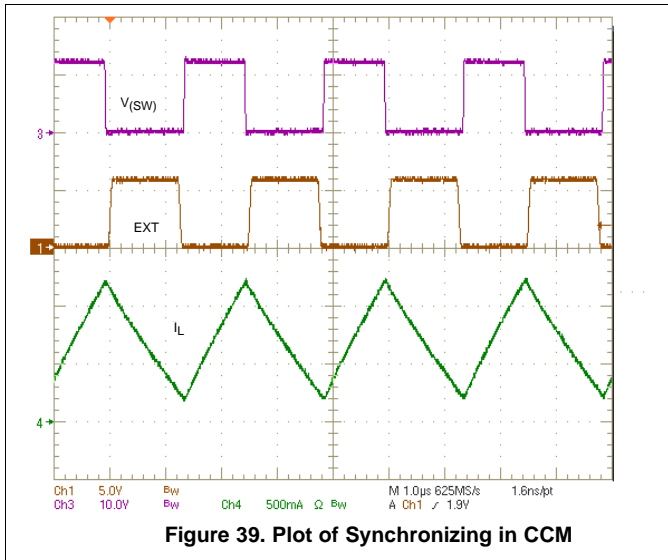

Figure 39. Plot of Synchronizing in CCM

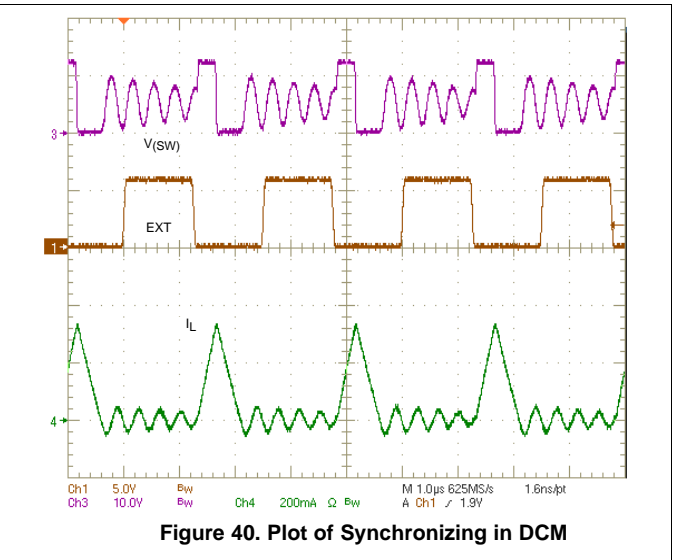

Figure 40. Plot of Synchronizing in DCM

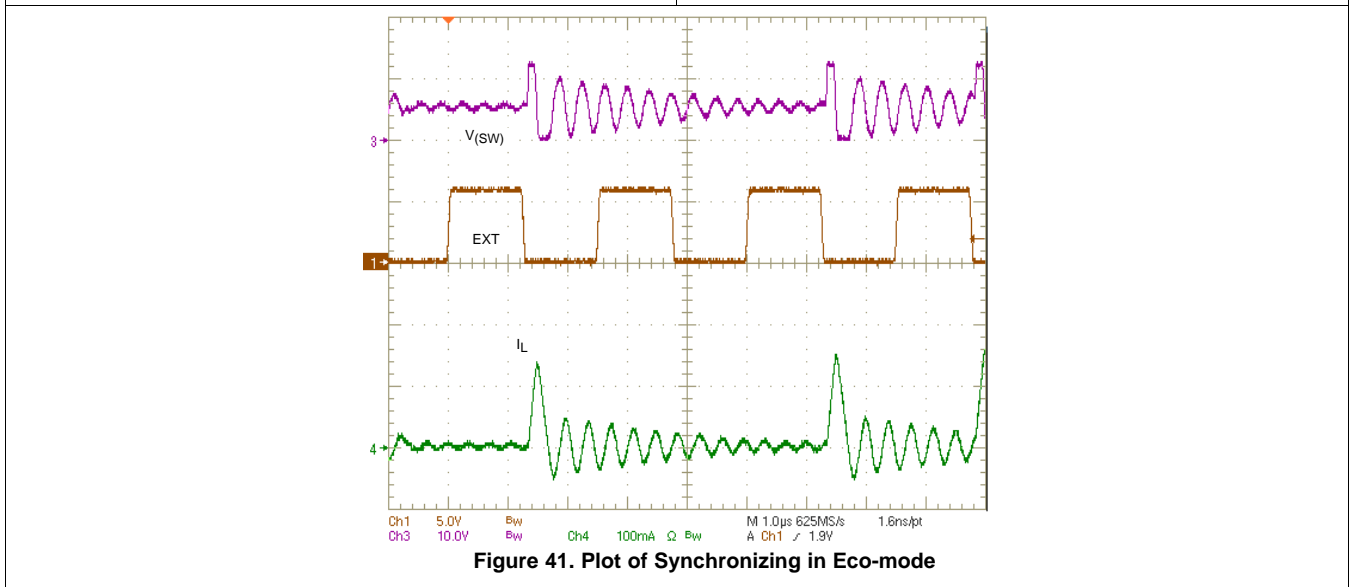

Figure 41. Plot of Synchronizing in Eco-mode

## Feature Description (continued)

### 7.3.13 Power Good (PWRGD Pin)

The PWRGD pin is an open drain output. When the FB pin is between 93% and 106% of the internal voltage reference the PWRGD pin is de-asserted and the pin floats. A pull-up resistor of 1 k $\Omega$  to a voltage source that is 5.5 V or less is recommended. A higher pull-up resistance reduces the amount of current drawn from the pull up voltage source when the PWRGD pin is asserted low. A lower pull-up resistance reduces the switching noise seen on the PWRGD signal. The PWRGD is in a defined state once the VIN input voltage is greater than 2 V but with reduced current sinking capability. The PWRGD achieves full current-sinking capability as VIN input voltage approaches 3 V.

The PWRGD pin is pulled low when the FB is lower than 90% or greater than 108% of the nominal internal reference voltage. Also, the PWRGD is pulled low, if the UVLO or thermal shutdown are asserted or the EN pin pulled low.

### 7.3.14 Overvoltage Protection

The TPS54361-Q1 device incorporates an output overvoltage protection (OVP) circuit to minimize voltage overshoot when recovering from output fault conditions or strong unload transients in designs with low output capacitance. For example, when the power supply output is overloaded the error amplifier compares the actual output voltage to the internal reference voltage. If the FB pin voltage is lower than the internal reference voltage for a considerable time, the output of the error amplifier increases to a maximum voltage corresponding to the peak current limit threshold. When the overload condition is removed, the regulator output rises and the error amplifier output transitions to the normal operating level. In some applications, the power supply output voltage can increase faster than the response of the error amplifier output resulting in an output overshoot.

The OVP feature minimizes output overshoot when using a low value output capacitor by comparing the FB pin voltage to the rising OVP threshold which is nominally 108% of the internal voltage reference. If the FB pin voltage is greater than the rising OVP threshold, the high-side MOSFET is immediately disabled to minimize output overshoot. When the FB voltage drops below the falling OVP threshold which is nominally 106% of the internal voltage reference, the high-side MOSFET resumes normal operation.

### 7.3.15 Thermal Shutdown

The TPS54361-Q1 device provides an internal thermal shutdown to protect the device when the junction temperature exceeds 176°C. The high-side MOSFET stops switching when the junction temperature exceeds the thermal trip threshold. Once the die temperature falls below 164°C, the device reinitiates the power up sequence controlled by discharging the SS/TR pin.

### 7.3.16 Small Signal Model for Loop Response

[Figure 42](#) shows a simplified equivalent model for the TPS54361-Q1 control loop which can be simulated to check the frequency response and dynamic load response. The error amplifier is a transconductance amplifier with a  $g_{m_{ea}}$  of 350  $\mu\text{A/V}$ . The error amplifier can be modeled using an ideal voltage controlled current source. The resistor,  $R_{(OEA)}$ , and capacitor,  $C_{(OEA)}$ , model the open loop gain and frequency response of the amplifier. The 1-mV AC voltage source between the nodes a and b effectively breaks the control loop for the frequency response measurements. Plotting [c-a](#) provides the small signal response of the frequency compensation. Plotting [a-b](#) provides the small signal response of the overall loop. The dynamic loop response can be evaluated by replacing the load resistor,  $R_{(L)}$ , with a current source with the appropriate load step amplitude and step rate in a time domain analysis. This equivalent model is only valid for continuous conduction mode (CCM) operation.

Feature Description (continued)

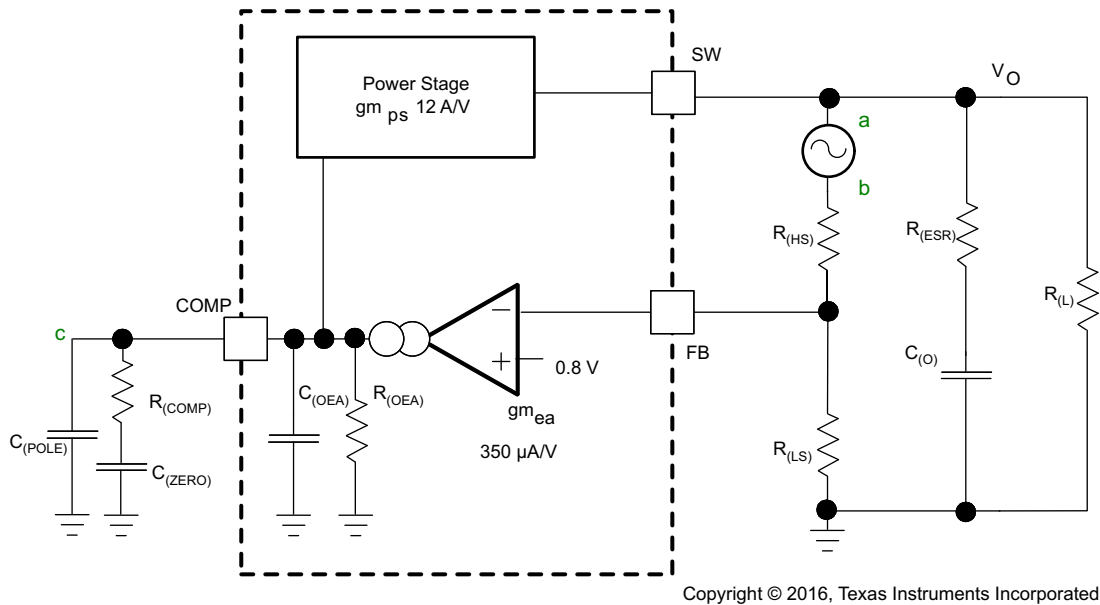

Copyright © 2016, Texas Instruments Incorporated

Figure 42. Small Signal Model for Loop Response

7.3.17 Simple Small Signal Model for Peak Current Mode Control

Figure 43 describes a simple small signal model that can be used to design the frequency compensation. The TPS54361-Q1 device power stage can be approximated by a voltage-controlled current source (duty cycle modulator) supplying current to the output capacitor and load resistor. The control to output transfer function is shown in Equation 14 and consists of a DC gain, one dominant pole, and one ESR zero. The quotient of the change in switch current and the change in COMP pin voltage (node c in Figure 42) is the power stage transconductance,  $g_{m_{ps}}$ . The  $g_{m_{ps}}$  for the TPS54361-Q1 device is 12 A/V. The low-frequency gain of the power stage is the product of the transconductance and the load resistance as shown in Equation 15.

As the load current increases and decreases, the low-frequency gain decreases and increases, respectively. This variation with the load may seem problematic at first glance, but fortunately the dominant pole moves with the load current (see Equation 16). The combined effect is highlighted by the dashed line in the right half of Figure 43. As the load current decreases, the gain increases and the pole frequency lowers, keeping the 0-dB crossover frequency the same with varying load conditions. The type of output capacitor chosen determines whether the ESR zero has a profound effect on the frequency compensation design. Using high ESR aluminum electrolytic capacitors may reduce the number frequency compensation components needed to stabilize the overall loop because the phase margin is increased by the ESR zero of the output capacitor (see Equation 17).

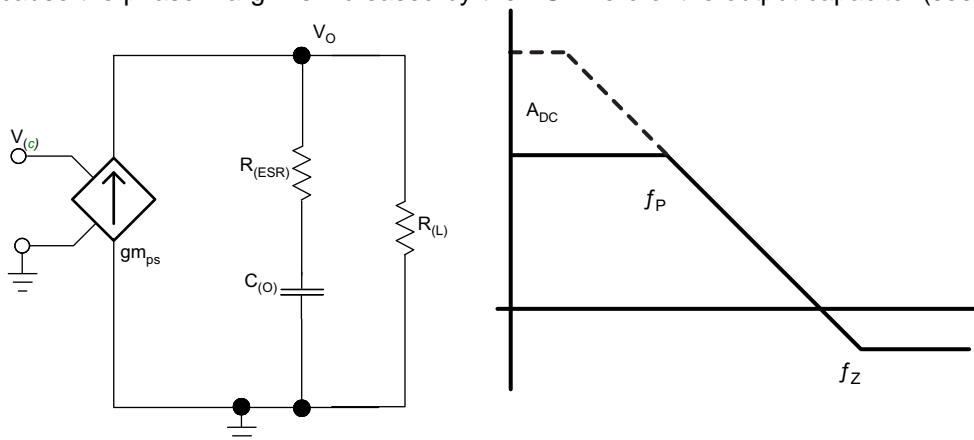

Figure 43. Simple Small Signal Model and Frequency Response for Peak Current Mode Control

**Feature Description (continued)**

$$\frac{V_O}{V_{(c)}} = A_{DC} \times \frac{\left(1 + \frac{s}{2\pi \times f_Z}\right)}{\left(1 + \frac{s}{2\pi \times f_P}\right)} \tag{14}$$

$$A_{DC} = g_{m_{ps}} \times R_{(L)} \tag{15}$$

$$f_P = \frac{1}{C_{(O)} \times R_{(L)} \times 2\pi} \tag{16}$$

$$f_Z = \frac{1}{C_{(O)} \times R_{(ESR)} \times 2\pi} \tag{17}$$

**7.3.18 Small Signal Model for Frequency Compensation**

The TPS54361-Q1 device uses a transconductance amplifier for the error amplifier and supports three of the commonly-used frequency compensation circuits. Compensation circuits Type 2A, Type 2B, and Type 1 are shown in Figure 44. Type 2 circuits are typically implemented in high bandwidth power-supply designs using low ESR output capacitors. The Type 1 circuit is used with power-supply designs with high-ESR aluminum electrolytic or tantalum capacitors. Equation 18 and Equation 19 relate the frequency response of the amplifier to the small signal model in Figure 44. The open-loop gain and bandwidth are modeled using the  $R_{(OEA)}$  and  $C_{(OEA)}$  shown in Figure 44. See the application section for a design example using a Type 2A network with a low ESR output capacitor.

Equation 18 through Equation 27 are provided as a reference. An alternative is to use WEBENCH software tools to create a design based on the power supply requirements.

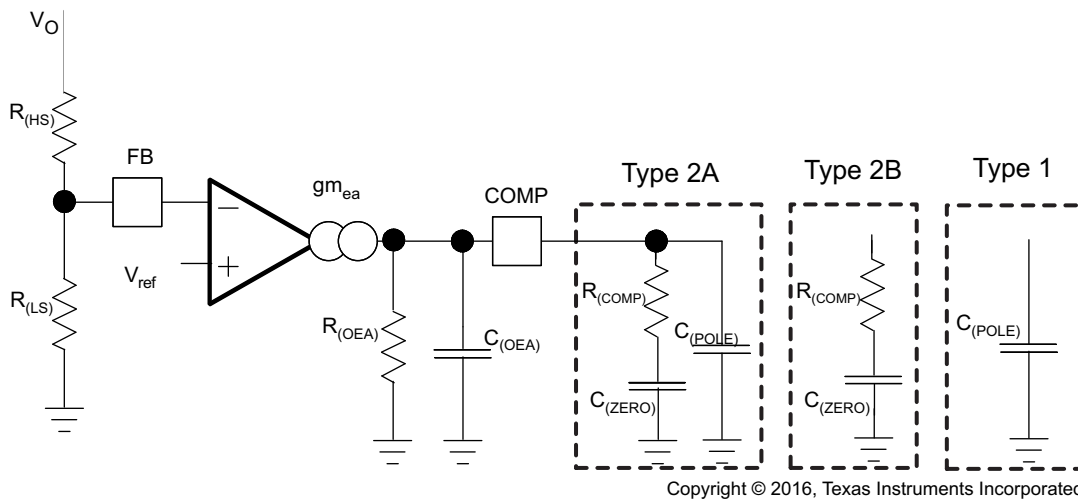

Copyright © 2016, Texas Instruments Incorporated

**Figure 44. Types of Frequency Compensation**

Feature Description (continued)

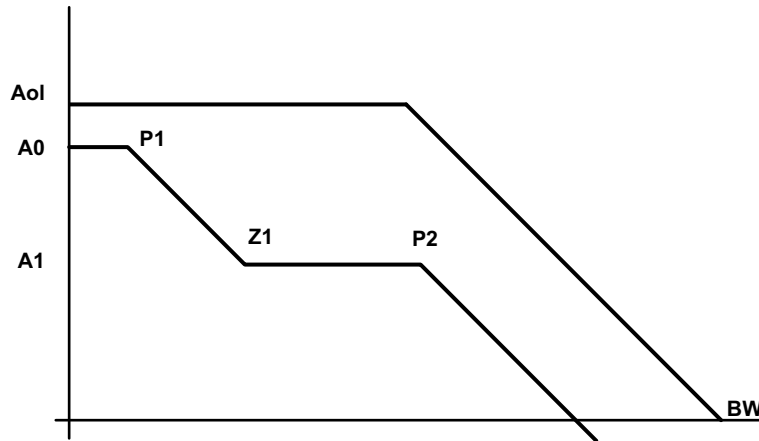

Figure 45. Frequency Response of the Type 2A and Type 2B Frequency Compensation

$$R_{(OEA)} = \frac{Aol(V/V)}{gm_{ea}} \quad (18)$$

$$C_{(OEA)} = \frac{gm_{ea}}{2\pi \times BW \text{ (Hz)}} \quad (19)$$

$$EA = A0 \times \frac{\left(1 + \frac{s}{2\pi \times f_{Z1}}\right)}{\left(1 + \frac{s}{2\pi \times f_{P1}}\right) \times \left(1 + \left(\frac{s}{2\pi \times f_{P2}}\right)\right)} \quad (20)$$

$$A0 = gm_{ea} \times R_{(OEA)} \times \frac{R_{(LS)}}{R_{(HS)} + R_{(LS)}} \quad (21)$$

$$A1 = gm_{ea} \times R_{(OEA)} \parallel R_{(COMP)} \times \frac{R_{(LS)}}{R_{(HS)} + R_{(LS)}} \quad (22)$$

$$P1 = \frac{1}{2\pi \times R_{(OEA)} \times C_{(ZERO)}} \quad (23)$$

$$Z1 = \frac{1}{2\pi \times R_{(COMP)} \times C_{(ZERO)}} \quad (24)$$

$$P2 = \frac{1}{2\pi \times R_{(COMP)} \parallel R_{(OEA)} \times (C_{(POLE)} + C_{(OEA)})} \text{ Type 2A} \quad (25)$$

$$P2 = \frac{1}{2\pi \times R_{(COMP)} \parallel R_{(OEA)} \times C_{(OEA)}} \text{ Type 2B} \quad (26)$$

$$P2 = \frac{1}{2\pi \times R_{(OEA)} \times (C_{(POLE)} + C_{(OEA)})} \text{ type 1} \quad (27)$$

## 7.4 Device Functional Modes

### 7.4.1 Operation with $V_{(VIN)} = < 4.5\text{ V}$ (Minimum $V_{(VIN)}$ )

The device is recommended to operate with input voltages above 4.5 V. The typical VIN UVLO threshold is 4.3 V and the device may operate at input voltages down to the UVLO voltage. At input voltages below the actual UVLO voltage, the device will not switch. If EN is externally pulled up to  $V_{(VIN)}$  using an external resistor divider or left floating, when  $V_{(VIN)}$  passes the UVLO threshold the device will become active. Switching is enabled, and the soft start sequence is initiated. The TPS54361-Q1 device starts at the soft start time determined by the external capacitance at the SS/TR pin.

### 7.4.2 Operation with EN Control

The enable threshold voltage is 1.2 V typical. With EN held below that voltage the device is disabled and switching is inhibited even if VIN is above its UVLO threshold. The IC quiescent current is reduced in this state. If the EN voltage is increased above the threshold while VIN is above its UVLO threshold, the device becomes active. Switching is enabled, and the soft start sequence is initiated. The TPS54361-Q1 device starts at the soft-start time determined by the external capacitance at the SS/TR pin.

### 7.4.3 Alternate Power Supply Topologies

#### 7.4.3.1 Inverting Power Supply

The TPS54361-Q1 can be used to convert a positive input voltage to a negative output voltage. Idea applications are amplifiers requiring a negative power supply. For a more detailed example see [SLVA317](#).

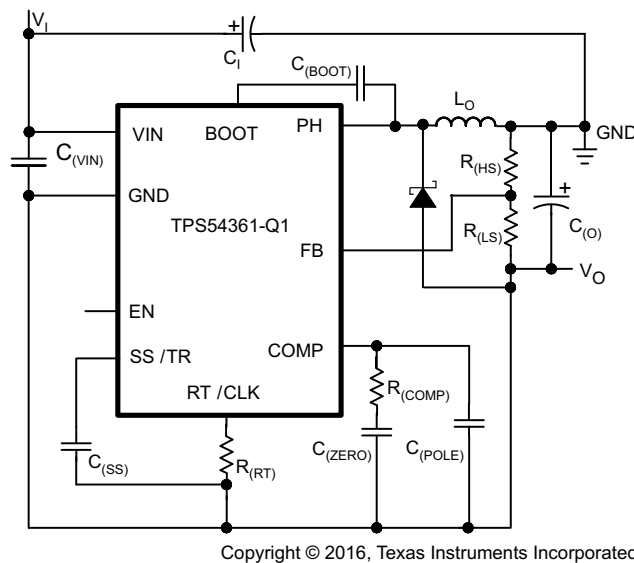
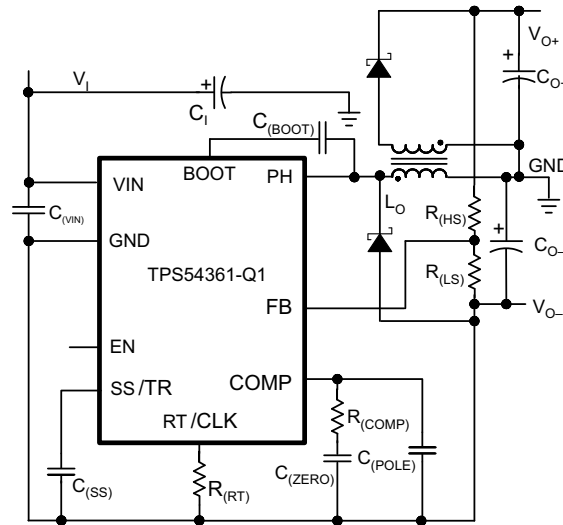

**Figure 46. TPS54361-Q1 Inverting Power Supply based on the Application Note, [SLVA317](#)**

#### 7.4.3.2 Split Rail Power Supply

The TPS54361-Q1 device can be used to convert a positive input voltage to a split rail positive and negative output voltage by using a coupled inductor. Idea applications are amplifiers requiring a split rail positive and negative voltage power supply. For a more detailed example see [SLVA369](#).

Device Functional Modes (continued)



Copyright © 2016, Texas Instruments Incorporated

Figure 47. TPS54361-Q1 Split Rail Power Supply based on the Application Note, [SLVA369](#)



## 8.2.2 Detailed Design Procedure

### 8.2.2.1 Custom Design with WEBENCH® Tools

[Click here](#) to create a custom design using the TPS54361-Q1 device with the WEBENCH® Power Designer.

1. Start by entering your  $V_{IN}$ ,  $V_{OUT}$ , and  $I_{OUT}$  requirements.
2. Optimize your design for key parameters like efficiency, footprint and cost using the optimizer dial and compare this design with other possible solutions from Texas Instruments.
3. The WEBENCH Power Designer provides you with a customized schematic along with a list of materials with real time pricing and component availability.
4. In most cases, you will also be able to:
  - Run electrical simulations to see important waveforms and circuit performance
  - Run thermal simulations to understand the thermal performance of your board
  - Export your customized schematic and layout into popular CAD formats
  - Print PDF reports for the design, and share your design with colleagues
5. Get more information about WEBENCH tools at [www.ti.com/WEBENCH](http://www.ti.com/WEBENCH).

### 8.2.2.2 Selecting the Switching Frequency

The first step is to choose a switching frequency for the regulator. Typically, the designer uses the highest switching frequency possible because the highest switching frequency produces the smallest solution size. High switching frequency allows for lower value inductors and smaller output capacitors compared to a power supply that switches at a lower frequency. The switching frequency that can be selected is limited by the minimum on-time of the internal power switch, the input voltage, the output voltage and the frequency foldback protection.

[Equation 28](#) and [Equation 29](#) must be used to calculate the upper limit of the switching frequency for the regulator. Choose the lower value result from the two equations. Switching frequencies higher than these values results in pulse skipping or the lack of overcurrent protection during a short circuit.

The typical minimum on time,  $t_{on}$ , is 100 ns for the TPS54361-Q1 device. For this example, the output voltage is 5 V and the maximum input voltage is 60 V, which allows for a maximum switch frequency up to 960 kHz to avoid pulse skipping from [Equation 28](#). To ensure overcurrent runaway is not a concern during short circuits use [Equation 28](#) to determine the maximum switching frequency for frequency foldback protection. With a maximum input voltage of 60 V, assuming a diode voltage of 0.7 V, inductor resistance of 25 mΩ, switch resistance of 87 mΩ, a current limit value of 4.7 A and short circuit output voltage of 0.1 V, the maximum switching frequency is 1220 kHz.

For this design, a lower switching frequency of 600 kHz is chosen to operate comfortably below the calculated maximums. To determine the timing resistance for a given switching frequency, use [Equation 30](#) or the curve in [Figure 6](#). The switching frequency is set by resistor R3 shown in [Figure 48](#). For 600 kHz operation, the closest standard value resistor is 162 kΩ.

$$f_{S(\text{skip}) \text{ max}} = \frac{1}{100 \text{ ns}} \times \left( \frac{3.5 \text{ A} \times 25 \text{ m}\Omega + 5 \text{ V} + 0.7 \text{ V}}{60 \text{ V} - 3.5 \text{ A} \times 87 \text{ m}\Omega + 0.7 \text{ V}} \right) = 960 \text{ kHz} \quad (28)$$

$$f_{S(\text{shift})} = \frac{8}{100 \text{ ns}} \times \left( \frac{4.7 \text{ A} \times 25 \text{ m}\Omega + 0.1 \text{ V} + 0.7 \text{ V}}{60 \text{ V} - 4.7 \text{ A} \times 87 \text{ m}\Omega + 0.7 \text{ V}} \right) = 1220 \text{ kHz} \quad (29)$$

$$RT \text{ (k}\Omega\text{)} = \frac{101756}{600 \text{ (kHz)}^{1.008}} = 161 \text{ k}\Omega \quad (30)$$

### 8.2.2.3 Output Inductor Selection ( $L_O$ )

To calculate the minimum value of the output inductor, use [Equation 31](#).

$K_{IND}$  is a ratio that represents the amount of inductor ripple current relative to the maximum output current. The inductor ripple current is filtered by the output capacitor. Therefore, choosing high inductor ripple currents impacts the selection of the output capacitor because the output capacitor must have a ripple current rating equal to or greater than the inductor ripple current. In general, the inductor ripple value is at the discretion of the designer, however, the following guidelines may be used.

For designs using low ESR output capacitors such as ceramics, a value as high as  $K_{IND} = 0.3$  may be desirable. When using higher ESR output capacitors,  $K_{IND} = 0.2$  yields better results. Because the inductor ripple current is part of the current mode PWM control system, the inductor ripple current must always be greater than 150 mA for stable PWM operation. In a wide input voltage regulator, choosing a relatively large inductor ripple current is best to provide sufficient ripple current with the input voltage at the minimum.

For this design example,  $K_{IND} = 0.3$  and the minimum inductor value is calculated to be 7.3  $\mu\text{H}$ . The nearest standard value is 8.2  $\mu\text{H}$ . It is important that the RMS current and saturation current ratings of the inductor not be exceeded. The RMS and peak inductor current can be found from [Equation 33](#) and [Equation 34](#). For this design, the RMS inductor current is 3.5 A and the peak inductor current is 3.97 A. The chosen inductor has a saturation current rating of 5.8 A and an RMS current rating of 5.05 A.

As the equation set demonstrates, lower ripple currents reduce the output voltage ripple of the regulator but require a larger value of inductance. Selecting higher ripple currents increases the output voltage ripple of the regulator but allows for a lower inductance value.

The current flowing through the inductor is the inductor ripple current plus the output current. During power up, faults or transient load conditions, the inductor current can increase above the peak inductor current level calculated above. In transient conditions, the inductor current can increase up to the switch current limit of the device. For this reason, the most conservative design approach is to choose an inductor with a saturation current rating equal to or greater than the switch current limit of the TPS54361-Q1 which is nominally 5.5 A.

$$L_O \text{ min} = \frac{V_I \text{ max} - V_O}{I_O \times K_{IND}} \times \frac{V_O}{V_I \text{ max} \times f_S} = \frac{60 \text{ V} - 5 \text{ V}}{3.5 \text{ A} \times 0.3} \times \frac{5 \text{ V}}{60 \text{ V} \times 600 \text{ kHz}} = 7.3 \mu\text{H} \quad (31)$$

$$I_{\text{rip}} = \frac{V_O \times (V_I \text{ max} - V_O)}{V_I \text{ max} \times L_O \times f_S} = \frac{5 \text{ V} \times (60 \text{ V} - 5 \text{ V})}{60 \text{ V} \times 8.2 \mu\text{H} \times 600 \text{ kHz}} = 0.932 \text{ A} \quad (32)$$

$$I_{L(\text{RMS})} = \sqrt{(I_O)^2 + \frac{1}{12} \times \left( \frac{V_O \times (V_I \text{ max} - V_O)}{V_I \text{ max} \times L_O \times f_S} \right)^2} = \sqrt{(3.5 \text{ A})^2 + \frac{1}{12} \times \left( \frac{5 \text{ V} \times (60 \text{ V} - 5 \text{ V})}{60 \text{ V} \times 8.2 \mu\text{H} \times 600 \text{ kHz}} \right)^2} = 3.5 \text{ A} \quad (33)$$

$$I_{L(\text{peak})} = I_O + \frac{I_{\text{rip}}}{2} = 3.5 \text{ A} + \frac{0.932 \text{ A}}{2} = 3.97 \text{ A} \quad (34)$$

#### 8.2.2.4 Output Capacitor

There are three primary considerations for selecting the value of the output capacitor. The output capacitor determines the modulator pole, the output voltage ripple, and how the regulator responds to a large change in load current. The output capacitance needs to be selected based on the most stringent of these three criteria.

The desired response to a large change in the load current is the first criteria. The output capacitor needs to supply the increased load current until the regulator responds to the load step. The regulator does not respond immediately to a large, fast increase in the load current such as transitioning from no load to a full load. The regulator usually needs two or more clock cycles for the control loop to sense the change in output voltage and adjust the peak switch current in response to the higher load. The output capacitance must be large enough to supply the difference in current for 2 clock cycles to maintain the output voltage within the specified range. [Equation 35](#) shows the minimum output capacitance necessary, where  $\Delta I_O$  is the change in output current,  $f_S$  is the regulators switching frequency and  $\Delta V_O$  is the allowable change in the output voltage. For this example, the transient load response is specified as a 4% change in  $V_O$  for a load step from 0.875 A to 2.625 A. Therefore,  $\Delta I_O$  is 2.625 A - 0.875 A = 1.75 A and  $\Delta V_O = 0.04 \times 5 = 0.2 \text{ V}$ . Using these numbers gives a minimum capacitance of 29.2  $\mu\text{F}$ . This value does not take the ESR of the output capacitor into account in the output voltage change. For ceramic capacitors, the ESR is usually small enough to be ignored. Aluminum electrolytic and tantalum capacitors have higher ESR that must be included in load step calculations.

The output capacitor must also be sized to absorb energy stored in the inductor when transitioning from a high to low load current. The catch diode of the regulator can not sink current so energy stored in the inductor can produce an output voltage overshoot when the load current rapidly decreases. A typical load step response is shown in [Figure 49](#). The excess energy absorbed in the output capacitor increases the voltage on the capacitor. The capacitor must be sized to maintain the desired output voltage during these transient periods. [Equation 36](#) calculates the minimum capacitance required to keep the output voltage overshoot to a desired value, where  $L_O$  is the value of the inductor,  $I_{OH}$  is the output current under heavy load,  $I_{OL}$  is the output under light load,  $V_f$  is the peak output voltage, and  $V_{(int)}$  is the initial voltage. For this example, the worst case load step is from 2.625 A to 0.875 A. The output voltage increases during this load transition and the stated maximum in our specification is 4 % of the output voltage which makes  $V_f = 1.04 \times 5 = 5.2$ .  $V_{(int)}$  is the initial capacitor voltage which is the nominal output voltage of 5 V. Using these numbers in [Equation 36](#) yields a minimum capacitance of 25  $\mu$ F.

[Equation 37](#) calculates the minimum output capacitance needed to meet the output voltage ripple specification, where  $f_{sw}$  is the switching frequency,  $V_{O(rip)}$  is the maximum allowable output voltage ripple, and  $I_{rip}$  is the inductor ripple current. [Equation 37](#) yields 7.8  $\mu$ F.

[Equation 38](#) calculates the maximum ESR an output capacitor can have to meet the output voltage ripple specification. [Equation 38](#) indicates the ESR must be less than 27 m $\Omega$ .

The most stringent criteria for the output capacitor is 29  $\mu$ F required to maintain the output voltage within regulation tolerance during a load transient.

Capacitance de-ratings for aging, temperature and dc bias increases this minimum value. For this example, two 47- $\mu$ F, 10-V ceramic capacitors with 5 m $\Omega$  of ESR is used. The derated capacitance is 58  $\mu$ F, well above the minimum required capacitance of 29  $\mu$ F.

Capacitors are generally rated for a maximum ripple current that can be filtered without degrading capacitor reliability. Some capacitor data sheets specify the root-mean-square (RMS) value of the maximum ripple current. [Equation 39](#) can be used to calculate the RMS ripple current that the output capacitor must support. For this example, [Equation 39](#) yields 269 mA.

$$C_{(O)} > \frac{2 \times \Delta I_O}{f_S \times \Delta V_O} = \frac{2 \times 1.75 \text{ A}}{600 \text{ kHz} \times 0.2 \text{ V}} = 29.2 \mu\text{F} \quad (35)$$

$$C_{(O)} > L_O \times \frac{\left( (I_{OH})^2 - (I_{OL})^2 \right)}{\left( (V_f)^2 - (V_{(int)})^2 \right)} = 8.2 \mu\text{H} \times \frac{\left( 2.625 \text{ A}^2 - 0.875 \text{ A}^2 \right)}{\left( 5.2 \text{ V}^2 - 5 \text{ V}^2 \right)} = 24.6 \mu\text{F} \quad (36)$$

$$C_{(O)} > \frac{1}{8 \times f_S} \times \frac{1}{\left( \frac{V_{O(rip)}}{I_{rip}} \right)} = \frac{1}{8 \times 600 \text{ kHz}} \times \frac{1}{\left( \frac{25 \text{ mV}}{0.932 \text{ A}} \right)} = 7.8 \mu\text{F} \quad (37)$$

$$R_{(ESR)} < \frac{V_{O(rip)}}{I_{rip}} = \frac{25 \text{ mV}}{0.932 \text{ A}} = 27 \text{ m}\Omega \quad (38)$$

$$I_{CO(RMS)} = \frac{V_O \times (V_{I \text{ min}} - V_O)}{\sqrt{12} \times V_{I \text{ min}} \times L_O \times f_S} = \frac{5 \text{ V} \times (60 \text{ V} - 5 \text{ V})}{\sqrt{12} \times 60 \text{ V} \times 8.2 \mu\text{H} \times 600 \text{ kHz}} = 269 \text{ mA} \quad (39)$$

### 8.2.2.5 Catch Diode

The TPS54361-Q1 device requires an external catch diode between the SW pin and GND. The selected diode must have a reverse voltage rating equal to or greater than  $V_{I \text{ max}}$ . The peak current rating of the diode must be greater than the maximum inductor current. Schottky diodes are typically a good choice for the catch diode because of the low forward voltage of these diodes. The lower the forward voltage of the diode, the higher the efficiency of the regulator.

Typically, diodes with higher voltage and current ratings have higher forward voltages. A diode with a minimum of 60 V reverse voltage is preferred to allow input voltage transients up to the rated voltage of the TPS54361-Q1 device.

For the example design, the Schottky diode was selected for its lower forward voltage and good thermal characteristics compared to smaller devices. The typical forward voltage of the diode is 0.55 V at 3.5 A.

The diode must also be selected with an appropriate power rating. The diode conducts the output current during the off-time of the internal power switch. The off-time of the internal switch is a function of the maximum input voltage, the output voltage, and the switching frequency. The output current during the off-time is multiplied by the forward voltage of the diode to calculate the instantaneous conduction losses of the diode. At higher switching frequencies, the AC losses of the diode must be taken into account. The AC losses of the diode are because of the charging and discharging of the junction capacitance and reverse recovery charge. Equation 40 is used to calculate the total power dissipation, including conduction losses and AC losses of the diode.

The selected diode has a junction capacitance of 90 pF. Using Equation 40 with the nominal voltage  $V_I$  of 12 V, the total loss in the diode is 1.13 W.

If the power supply spends a significant amount of time at light load currents or in sleep mode, consider using a diode which has a low leakage current and slightly higher forward voltage drop.

$$P_D = \frac{(V_I - V_O) \times I_O \times V_d}{V_I} + \frac{C_j \times f_S \times (V_I + V_d)^2}{2} = \frac{(12 \text{ V} - 5 \text{ V}) \times 3.5 \text{ A} \times 0.55 \text{ V}}{12 \text{ V}} + \frac{90 \text{ pF} \times 600 \text{ kHz} \times (12 \text{ V} + 0.55 \text{ V})^2}{2} = 1.13 \text{ W} \quad (40)$$

### 8.2.2.6 Input Capacitor

The TPS54361-Q1 device requires a high quality ceramic type X5R or X7R input decoupling capacitor with at least 3  $\mu\text{F}$  of effective capacitance. Some applications benefit from additional bulk capacitance. The effective capacitance includes any loss of capacitance because of DC-bias effects. The voltage rating of the input capacitor must be greater than the maximum input voltage. The capacitor must also have a ripple current rating greater than the maximum input current ripple of the TPS54361-Q1 device. The input ripple current can be calculated using Equation 41.

The value of a ceramic capacitor varies significantly with temperature and the dc bias applied to the capacitor. The capacitance variations because of temperature can be minimized by selecting a dielectric material that is more stable over temperature. X5R and X7R ceramic dielectrics are usually selected for switching regulator capacitors because they have a high capacitance to volume ratio and are fairly stable over temperature. The input capacitor must also be selected with consideration for the dc bias. The effective value of a capacitor decreases as the dc bias across a capacitor increases.

For this example design, a ceramic capacitor with at least a 60 V voltage rating is required to support the maximum input voltage. Common standard ceramic capacitor voltage ratings include 4 V, 6.3 V, 10 V, 16 V, 25 V, 50 V or 100 V. For this example, two 2.2- $\mu\text{F}$ , 100-V capacitors in parallel are used.

The input capacitance value determines the input ripple voltage of the regulator. The input voltage ripple can be calculated using Equation 42. Using the design example values,  $I_O = 3.5 \text{ A}$ ,  $C_I = 4.4 \mu\text{F}$ ,  $f_S = 600 \text{ kHz}$ , yields an input voltage ripple of 331 mV and a RMS input ripple current of 1.72 A.

$$I_{C_I(\text{RMS})} = I_O \times \sqrt{\frac{V_O}{V_{I \text{ min}}} \times \frac{(V_{I \text{ min}} - V_O)}{V_{I \text{ min}}}} = 3.5 \text{ A} \sqrt{\frac{5 \text{ V}}{8.5 \text{ V}} \times \frac{(8.5 \text{ V} - 5 \text{ V})}{8.5 \text{ V}}} = 1.72 \text{ A} \quad (41)$$

$$\Delta V_I = \frac{I_O \times 0.25}{C_I \times f_S} = \frac{3.5 \text{ A} \times 0.25}{4.4 \mu\text{F} \times 600 \text{ kHz}} = 331 \text{ mV} \quad (42)$$

### 8.2.2.7 Slow-Start Capacitor

The slow-start capacitor determines the minimum amount of time required for the output voltage to reach its nominal programmed value during power-up. This feature of the slow-start capacitor is useful if a load requires a controlled voltage slew rate. This feature is also used if the output capacitance is large and would require large amounts of current to quickly charge the capacitor to the output voltage level. The large currents necessary to charge the capacitor can make the TPS54361-Q1 device reach the current limit or excessive current draw from the input power supply may cause the input voltage rail to sag. Limiting the output voltage slew rate solves both of these problems.

The slow start time must be long enough to allow the regulator to charge the output capacitor up to the output voltage without drawing excessive current. Equation 43 can be used to find the minimum slow start time,  $t_{SS}$ , necessary to charge the output capacitor,  $C_{(O)}$ , from 10% to 90% of the output voltage,  $V_O$ , with an average slow start current of  $I_{SS(AV)}$ . In the example, to charge the effective output capacitance of 58  $\mu\text{F}$  up to 5 V with an average current of 1 A requires a 0.2 ms slow start time.

Once the slow start time is known, the slow start capacitor value can be calculated using Equation 5. For the example circuit, the slow start time is not too critical because the output capacitor value is  $2 \times 47 \mu\text{F}$  which does not require much current to charge to 5 V. The example circuit has the slow start time set to an arbitrary value of 3.5 ms which requires a 9.3-nF slow start capacitor calculated by Equation 44. For this design, the next larger standard value of 10 nF is used.

$$t_{SS} > \frac{C_{(O)} \times V_O \times 0.8}{I_{SS(AV)}} \quad (43)$$

$$C_{SS} \text{ (nF)} = \frac{t_{SS} \text{ (ms)} \times I_{SS} \text{ (\mu A)}}{V_{ref} \text{ (V)} \times 0.8} = \frac{3.5 \text{ ms} \times 1.7 \mu\text{A}}{(0.8 \text{ V} \times 0.8)} = 9.3 \text{ nF} \quad (44)$$

### 8.2.2.8 Bootstrap Capacitor Selection

A 0.1- $\mu\text{F}$  ceramic capacitor must be connected between the BOOT and SW pins for proper operation. A ceramic capacitor with X5R or better grade dielectric is recommended. The capacitor must have a 10 V or higher voltage rating.

### 8.2.2.9 Undervoltage Lockout Set Point

The Undervoltage Lockout (UVLO) can be adjusted using an external voltage divider on the EN pin of the TPS54361-Q1 device. The UVLO has two thresholds, one for power up when the input voltage is rising and one for power down or brown outs when the input voltage is falling. For the example design, the supply must turn on and start switching once the input voltage increases above 6.5 V (UVLO start). After the regulator starts switching, it must continue to do so until the input voltage falls below 5 V (UVLO stop).

Programmable UVLO threshold voltages are set using the resistor divider of R1 and R2 between the VIN pin and ground connected to the EN pin. Equation 3 and Equation 4 calculate the resistance values necessary. For the example application, a 442 k $\Omega$  between the VIN and EN pins (R1) and a 90.9 k $\Omega$  between EN and ground (R2) are required to produce the 6.5-V and 5-V start and stop voltages.

$$R1 = \frac{V_{START} - V_{STOP}}{I_{hys}} = \frac{6.5 \text{ V} - 5 \text{ V}}{3.4 \mu\text{A}} = 441 \text{ k}\Omega \quad (45)$$

$$R2 = \frac{V_{(EN)}}{\frac{V_{START} - V_{(EN)}}{R1} + I1} = \frac{1.2 \text{ V}}{\frac{6.5 \text{ V} - 1.2 \text{ V}}{442 \text{ k}\Omega} + 1.2 \mu\text{A}} = 90.9 \text{ k}\Omega \quad (46)$$

### 8.2.2.10 Output Voltage and Feedback Resistors Selection

The voltage divider of R5 and R6 sets the output voltage. For the example design, 10.2 k $\Omega$  was selected for R6. Using Equation 2, R5 is calculated as 53.5 k $\Omega$ . The nearest standard 1% resistor is 53.6 k $\Omega$ . Because of the input current of the FB pin, the current flowing through the feedback network must be greater than 1  $\mu\text{A}$  to maintain the output voltage accuracy. This requirement is satisfied if the value of R6 is less than 800 k $\Omega$ . Choosing higher resistor values decreases quiescent current and improves efficiency at low output currents but may also introduce noise immunity problems.

$$R5 = R6 \times \frac{V_O - 0.8 \text{ V}}{0.8 \text{ V}} = 10.2 \text{ k}\Omega \times \left( \frac{5 \text{ V} - 0.8 \text{ V}}{0.8 \text{ V}} \right) = 53.5 \text{ k}\Omega \quad (47)$$

### 8.2.2.11 Compensation

There are several methods to design compensation for DC-DC regulators. The method presented here is easy to calculate and ignores the effects of the slope compensation that is internal to the device. Because the slope compensation is ignored, the actual crossover frequency is lower than the crossover frequency used in the calculations. This method assumes the crossover frequency is between the modulator pole and the ESR zero and the ESR zero is at least ten-times greater the modulator pole.

To get started, the modulator pole,  $f_{P(\text{mod})}$ , and the ESR zero,  $f_{Z1}$  must be calculated using [Equation 48](#) and [Equation 49](#). For  $C_{(O)}$ , use a derated value of 58.3  $\mu\text{F}$ . Use equations [Equation 50](#) and [Equation 51](#) to estimate a starting point for the crossover frequency,  $f_{CO}$ . For the example design,  $f_{P(\text{mod})}$  is 1912 Hz and  $f_{Z(\text{mod})}$  is 1092 kHz. [Equation 49](#) is the geometric mean of the modulator pole and the ESR zero and [Equation 51](#) is the mean of modulator pole and the switching frequency. [Equation 50](#) yields 45.7 kHz and [Equation 51](#) gives 23.9 kHz. Use the lower value of [Equation 50](#) or [Equation 51](#) for an initial crossover frequency. For this example, the target  $f_{CO}$  is 23.9 kHz.

Next, the compensation components are calculated. A resistor in series with a capacitor is used to create a compensating zero. A capacitor in parallel to these two components forms the compensating pole.

$$f_{P(\text{mod})} = \frac{I_O \max}{2 \times \pi \times V_O \times C_{(O)}} = \frac{3.5 \text{ A}}{2 \times \pi \times 5 \text{ V} \times 58.3 \mu\text{F}} = 1912 \text{ Hz} \quad (48)$$

$$f_{Z(\text{mod})} = \frac{1}{2 \times \pi \times R6 \times C4} = \frac{1}{2 \times \pi \times 2.5 \text{ m}\Omega \times 58.3 \mu\text{F}} = 1092 \text{ kHz}$$

where

- $C_{(O)}$  is the parallel combination of C6 and C7 [Figure 48](#) (49)

$$f_{CO} = \sqrt{f_{P(\text{mod})} \times f_{Z(\text{mod})}} = \sqrt{1912 \text{ Hz} \times 1092 \text{ kHz}} = 45.7 \text{ kHz} \quad (50)$$

$$f_{CO} = \sqrt{f_{P(\text{mod})} \times \frac{f_S}{2}} = \sqrt{1912 \text{ Hz} \times \frac{600 \text{ kHz}}{2}} = 23.9 \text{ kHz} \quad (51)$$

To determine the compensation resistor, R4, use [Equation 52](#). Assume the power stage transconductance,  $g_{m_{ps}}$ , is 12 A/V. The output voltage,  $V_O$ , reference voltage,  $V_{ref}$ , and amplifier transconductance,  $g_{m_{ea}}$ , are 5 V, 0.8 V and 350  $\mu\text{A/V}$ , respectively. R4 is calculated to be 13 k $\Omega$  which is a standard value. Use [Equation 53](#) to set the compensation zero to the modulator pole frequency. [Equation 53](#) yields 6404 pF for compensating capacitor C5. 6800 pF is used for this design.

$$R4 = \left( \frac{2 \times \pi \times f_{CO} \times C_O}{g_{m_{ps}}} \right) \times \left( \frac{V_O}{V_{ref} \times g_{m_{ea}}} \right) = \left( \frac{2 \times \pi \times 23.9 \text{ kHz} \times 58.3 \mu\text{F}}{12 \text{ A/V}} \right) \times \left( \frac{5 \text{ V}}{0.8 \text{ V} \times 350 \mu\text{A/V}} \right) = 13 \text{ k}\Omega \quad (52)$$

$$C5 = \frac{1}{2 \times \pi \times R4 \times f_{P(\text{mod})}} = \frac{1}{2 \times \pi \times 13 \text{ k}\Omega \times 1912 \text{ Hz}} = 6404 \text{ pF} \quad (53)$$

A compensation pole can be implemented if desired by adding capacitor C8 in parallel with the series combination of R4 and C5. Use the larger value calculated from [Equation 54](#) and [Equation 55](#) for C8 to set the compensation pole. The selected value of C8 is 39 pF for this design example.

$$C8 = \frac{C4 \times R6}{R4} = \frac{58.3 \mu\text{F} \times 2.5 \text{ m}\Omega}{13 \text{ k}\Omega} = 11.2 \text{ pF} \quad (54)$$

$$C8 = \frac{1}{R4 \times f_S \times \pi} = \frac{1}{13 \text{ k}\Omega \times 600 \text{ kHz} \times \pi} = 40.8 \text{ pF} \quad (55)$$

### 8.2.2.12 Discontinuous Conduction Mode and Eco-mode Boundary

With an input voltage of 12 V, the power supply enters discontinuous conduction mode when the output current is less than 300 mA. The power supply enters Eco-mode when the output current is lower than 24 mA. The input current draw is 260  $\mu\text{A}$  with no load.

### 8.2.3 Application Curves

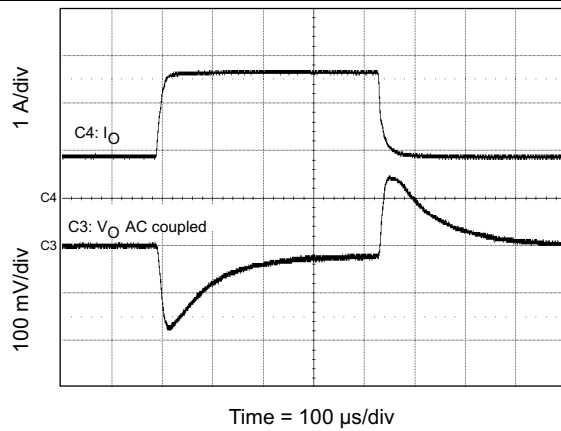

Figure 49. Load Transient

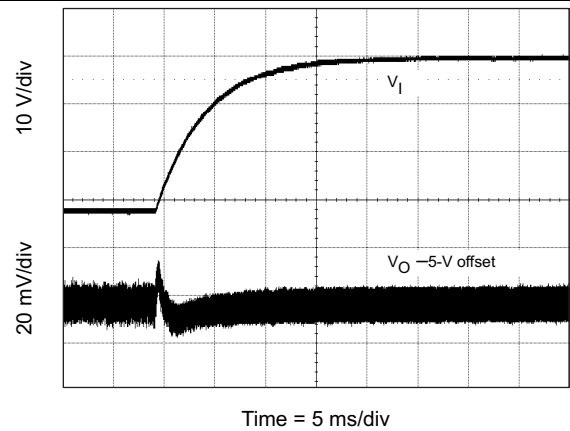

Figure 50. Line Transient (8 V to 40 V)

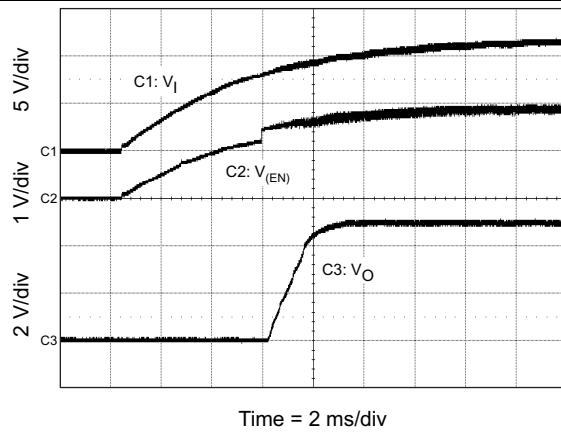

Figure 51. Startup With VIN

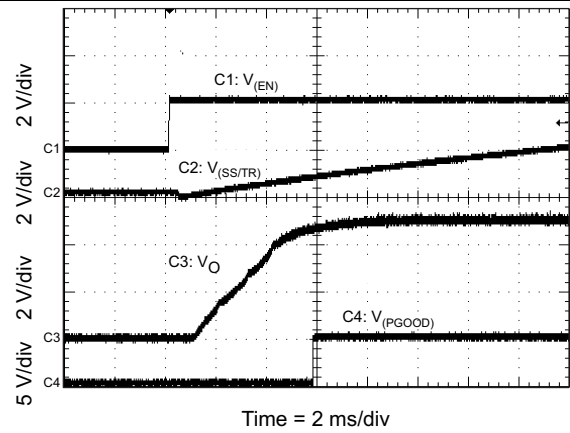

Figure 52. Startup With EN

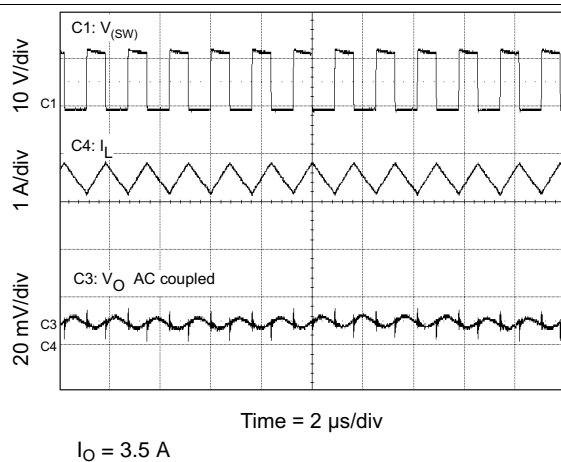

Figure 53. Output Ripple CCM

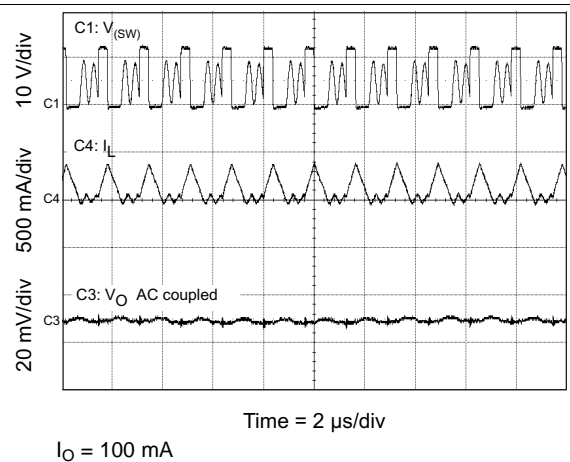
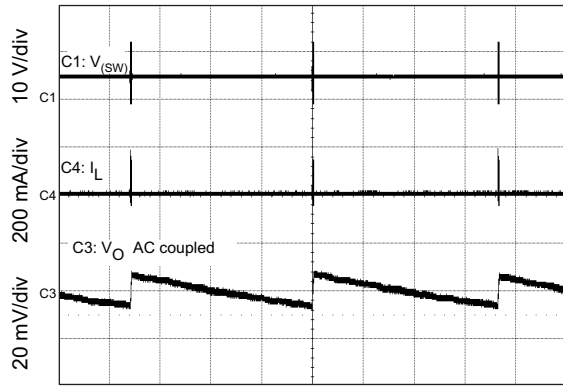
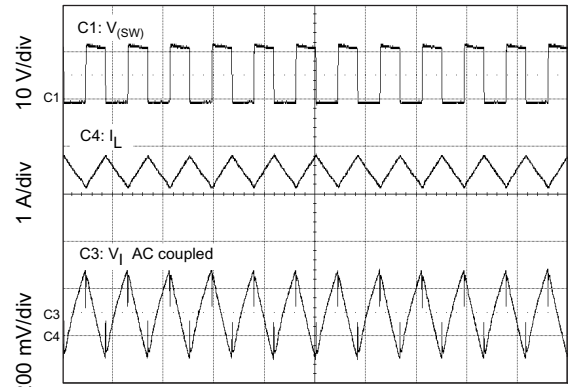

Figure 54. Output Ripple DCM



No Load  
Time = 2 ms/div

Figure 55. Output Ripple PSM



$I_O = 3.5 \text{ A}$   
Time = 2  $\mu\text{s}/\text{div}$

Figure 56. Input Ripple CCM

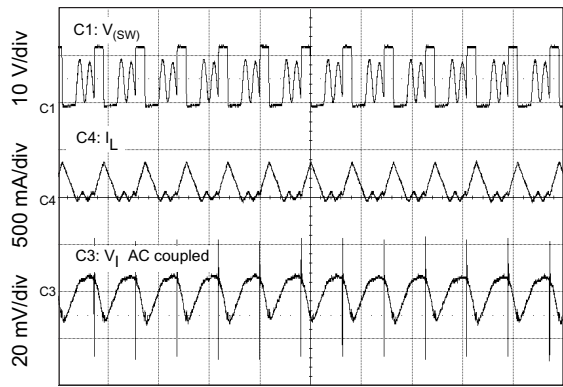

$I_O = 100 \text{ mA}$   
Time = 2  $\mu\text{s}/\text{div}$

Figure 57. Input Ripple DCM

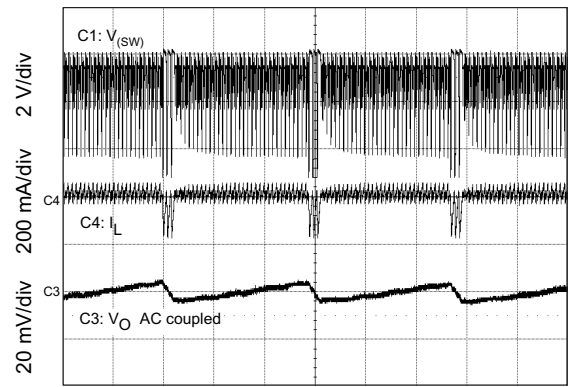

$V_I = 5.5 \text{ V}$   
 $V_O = 5 \text{ V}$   
No load  
EN floating  
Time = 20  $\mu\text{s}/\text{div}$

Figure 58. Low-Dropout Operation

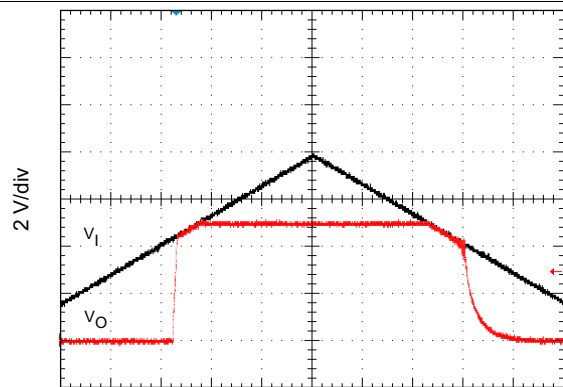

$I_O = 100 \text{ mA}$   
EN floating  
Time = 40  $\mu\text{s}/\text{div}$

Figure 59. Low-Dropout Operation

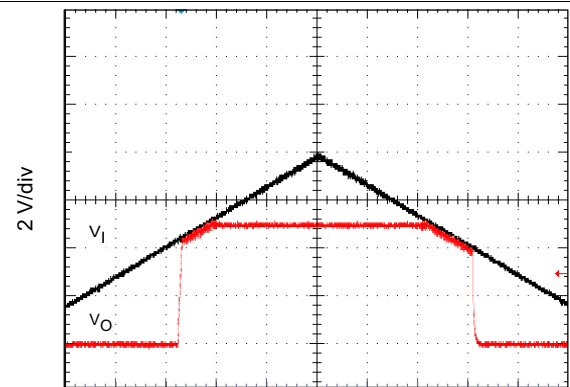

$I_O = 1 \text{ A}$   
EN floating  
Time = 40  $\mu\text{s}/\text{div}$

Figure 60. Low-Dropout Operation

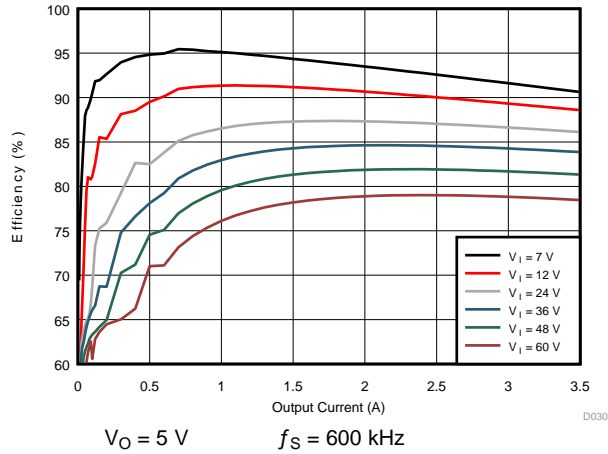

Figure 61. Efficiency Versus Load Current

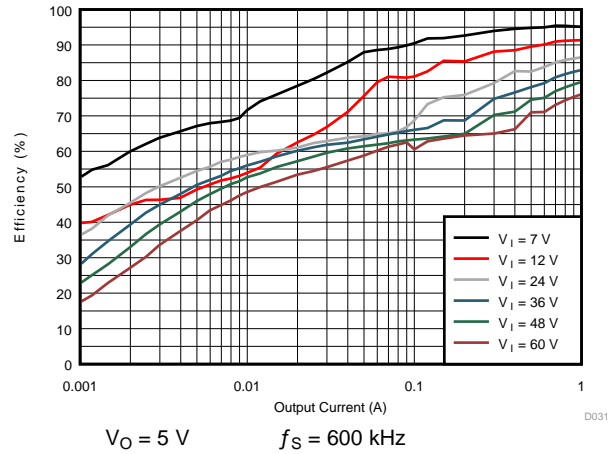

Figure 62. Light-Load Efficiency

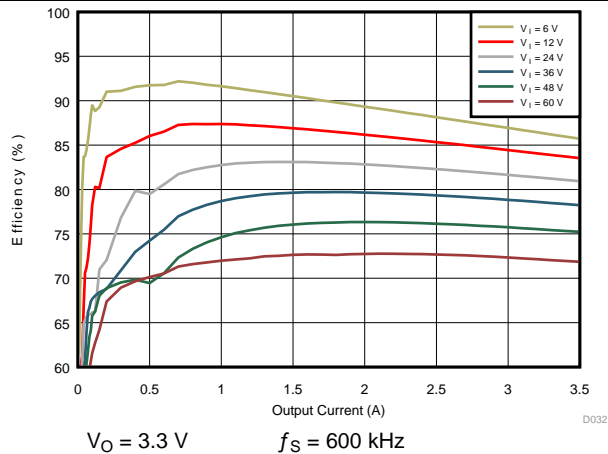

Figure 63. Efficiency Versus Load Current

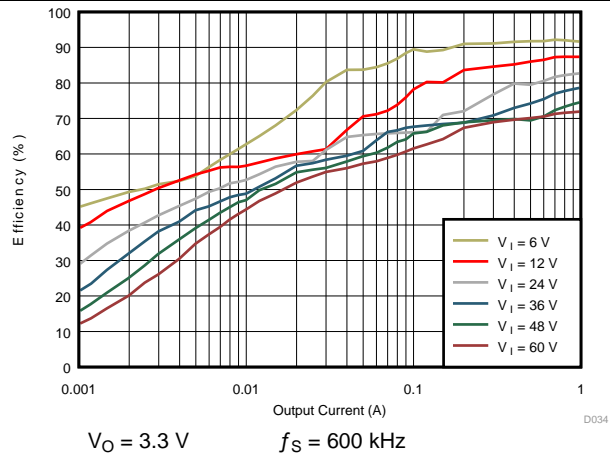

Figure 64. Light-Load Efficiency

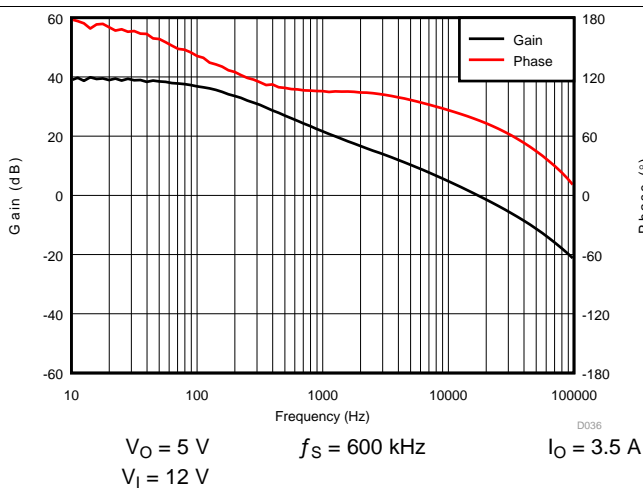

Figure 65. Overall Loop-Frequency Response

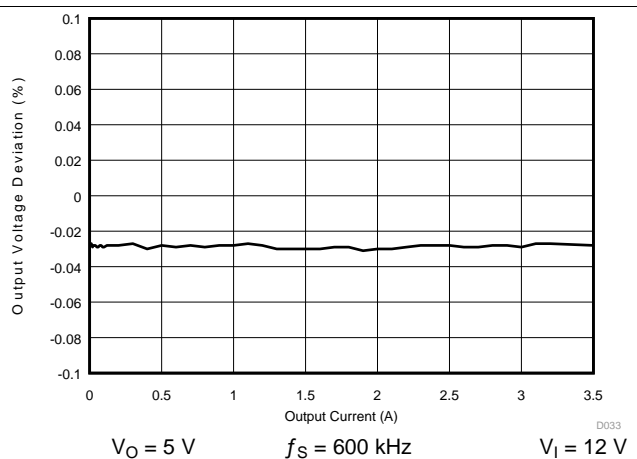
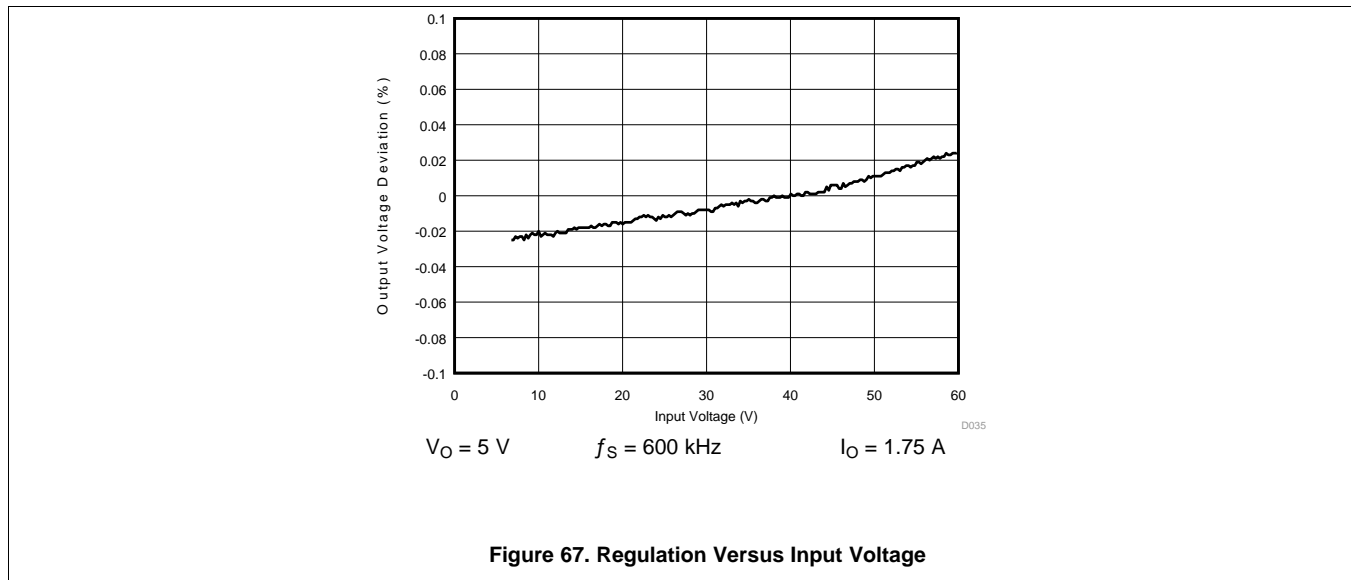

Figure 66. Regulation Versus Load Current



## 9 Power Supply Recommendations

The device is designed to operate from an input voltage supply range between 4.5 V and 60 V. This input supply should be well regulated. If the input supply is located more than a few inches from the TPS54361-Q1 converter additional bulk capacitance may be required in addition to the ceramic bypass capacitors. An electrolytic capacitor with a value of 100  $\mu\text{F}$  is a typical choice.

## 10 Layout

### 10.1 Layout Guidelines

Layout is a critical portion of good power supply design. There are several signal paths that conduct fast changing currents or voltages that can interact with stray inductance or parasitic capacitance to generate noise or degrade performance. See [Figure 68](#) for a PCB layout example.

- To reduce parasitic effects, the VIN pin should be bypassed to ground with a low ESR ceramic bypass capacitor with X5R or X7R dielectric.
- Care should be taken to minimize the loop area formed by the bypass capacitor connections, the VIN pin, and the anode of the catch diode. The SW pin should be routed to the cathode of the catch diode and to the output inductor. Since the SW connection is the switching node, the catch diode and output inductor should be located close to the SW pins, and the area of the PCB conductor minimized to prevent excessive capacitive coupling.
- The GND pin should be tied directly to the thermal pad under the IC. The thermal pad should be connected to internal PCB ground planes using multiple vias directly under the IC.
- For operation at full rated load, the top side ground area must provide adequate heat dissipating area.
- The RT/CLK pin is sensitive to noise so the RT resistor should be located as close as possible to the IC and routed with minimal lengths of trace.
- The additional external components can be placed approximately as shown.
- It may be possible to obtain acceptable performance with alternate PCB layouts, however this layout has been shown to produce good results and is meant as a guideline.

Boxing in the components in the design of [Figure 48](#) the estimated printed circuit board surface area is 1.025 in<sup>2</sup> (661 mm<sup>2</sup>). This area does not include test points or connectors. If the area needs to be reduced, this can be done by using a two sided assembly and replacing the 0603 sized passives with a smaller sized equivalent.

## Layout Guidelines (continued)

### 10.1.1 Power Dissipation Estimate

The following formulas show how to estimate the TPS54361-Q1 power dissipation under continuous conduction mode (CCM) operation. These equations must not be used if the device is operating in discontinuous conduction mode (DCM).

The power dissipation of the IC includes conduction loss ( $P_{CON}$ ), switching loss  $E$ , gate drive loss ( $P_G$ ) and supply current ( $P_Q$ ). Example calculations are shown with the 12-V typical input voltage of the design example.

#### 1. Conduction loss

$$P_{CON} = (I_O)^2 \times r_{DS(on)} \times \left( \frac{V_O}{V_I} \right) = 3.5 \text{ A}^2 \times 87 \text{ m}\Omega \times \frac{5 \text{ V}}{12 \text{ V}} = 0.45 \text{ W}$$

where

- $I_O$  is the output current (A)
  - $r_{DS(on)}$  is the on-resistance of the high-side MOSFET ( $\Omega$ )
  - $V_O$  is the output voltage (V)
  - $V_{(VIN)}$  is the input voltage (V)
- (56)

#### 2. Switching loss:

$$E = V_I \times f_S \times I_O \times t_r = 12 \text{ V} \times 600 \text{ kHz} \times 3.5 \text{ A} \times 4.9 \text{ ns} = 0.123 \text{ W}$$

where

- $E$  is the switching loss
  - $f_S$  is the switching frequency (Hz)
  - $t_r$  is the SW pin voltage rise time and can be estimated by  $t_{rise} = V_{(VIN)} \times 0.16 \text{ ns/V} + 3 \text{ ns}$
- (57)

#### 3. Gate charge loss:

$$P_G = V_{(VIN)} \times Q_g \times f_S = 12 \text{ V} \times 3 \text{ nC} \times 600 \text{ kHz} = 0.022 \text{ W}$$

where

- $Q_g$  is the total gate charge of the internal MOSFET
- (58)

#### 4. Quiescent current loss:

$$P_Q = V_{(VIN)} \times I_Q = 12 \text{ V} \times 152 \text{ }\mu\text{A} = 0.0018 \text{ W}$$

where

- $I_Q$  is the operating nonswitching supply current
- (59)

Therefore,

$$P_{tot} = P_{CON} + E + P_G + P_Q = 0.45 \text{ W} + 0.123 \text{ W} + 0.022 \text{ W} + 0.0018 \text{ W} = 0.597 \text{ W}$$
(60)

For given  $T_A$ :

$$T_J = T_A + R_{th} \times P_{tot}$$

where

- $T_A$  is the ambient temperature ( $^{\circ}\text{C}$ )
  - $T_J$  is the junction temperature ( $^{\circ}\text{C}$ )
  - $P_{tot}$  is the total device power dissipation (W)
  - $R_{th}$  is the thermal resistance of the package ( $^{\circ}\text{C/W}$ )
- (61)

For given  $T_{Jmax} = 150^{\circ}\text{C}$ :

$$T_{Amax} = T_{Jmax} - R_{th} \times P_{tot}$$

where

- $T_{Jmax}$  is maximum junction temperature ( $^{\circ}\text{C}$ )
  - $T_{Amax}$  is maximum ambient temperature ( $^{\circ}\text{C}$ )
- (62)

Additional power losses occur in the regulator circuit because of the inductor AC and DC losses, the catch diode, and PCB trace resistance impacting the overall efficiency of the regulator.

## 10.2 Layout Example

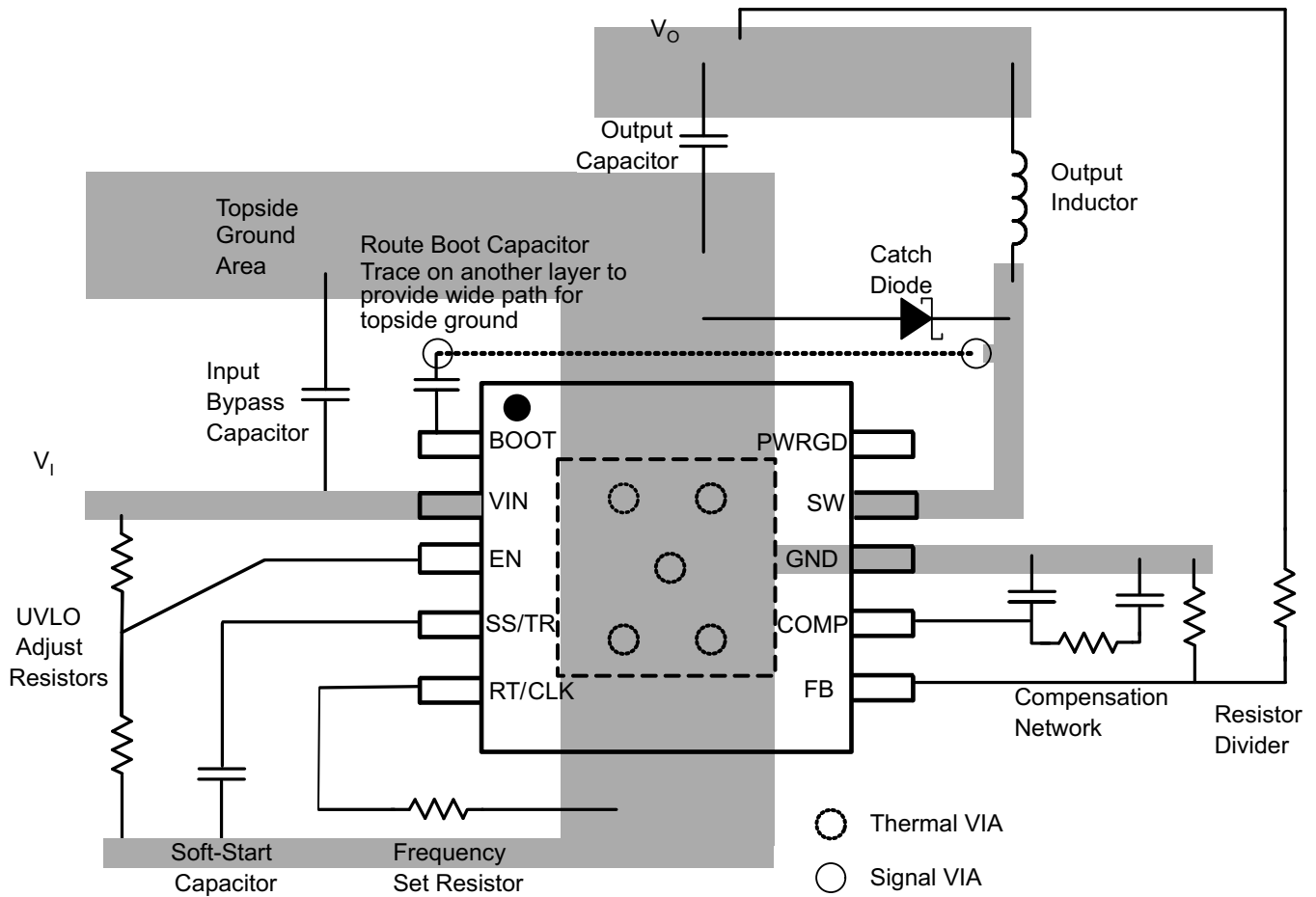

Figure 68. PCB Layout Example

## 11 Device and Documentation Support

### 11.1 Device Support

#### 11.1.1 Development Support

For the TPS54360 and TPS54361 Family Design Excel Tool, see [SLVC452](#)

### 11.2 Documentation Support

#### 11.2.1 Related Documentation

For related documentation see the following:

- *Create an Inverting Power Supply From a Step-Down Regulator*, [SLVA317](#)
- *Creating a Split-Rail Power Supply With a Wide Input Voltage Buck Regulator*, [SLVA369](#)
- *Evaluation Module for the TPS54361 Step-Down Converter*, [SLVU922](#)

#### 11.2.2 Custom Design with WEBENCH® Tools

[Click here](#) to create a custom design using the TPS54361-Q1 device with the WEBENCH® Power Designer.

1. Start by entering your  $V_{IN}$ ,  $V_{OUT}$ , and  $I_{OUT}$  requirements.
2. Optimize your design for key parameters like efficiency, footprint and cost using the optimizer dial and compare this design with other possible solutions from Texas Instruments.
3. The WEBENCH Power Designer provides you with a customized schematic along with a list of materials with real time pricing and component availability.
4. In most cases, you will also be able to:
  - Run electrical simulations to see important waveforms and circuit performance
  - Run thermal simulations to understand the thermal performance of your board
  - Export your customized schematic and layout into popular CAD formats
  - Print PDF reports for the design, and share your design with colleagues
5. Get more information about WEBENCH tools at [www.ti.com/WEBENCH](http://www.ti.com/WEBENCH).

### 11.3 Receiving Notification of Documentation Updates

To receive notification of documentation updates — go to the product folder for your device on ti.com. In the upper right-hand corner, click the Alert me button to register and receive a weekly digest of product information that has changed (if any). For change details, check the revision history of any revised document

### 11.4 Community Resources

The following links connect to TI community resources. Linked contents are provided "AS IS" by the respective contributors. They do not constitute TI specifications and do not necessarily reflect TI's views; see TI's [Terms of Use](#).

**TI E2E™ Online Community** *TI's Engineer-to-Engineer (E2E) Community*. Created to foster collaboration among engineers. At [e2e.ti.com](http://e2e.ti.com), you can ask questions, share knowledge, explore ideas and help solve problems with fellow engineers.

**Design Support** *TI's Design Support* Quickly find helpful E2E forums along with design support tools and contact information for technical support.

### 11.5 Trademarks

Eco-mode, E2E are trademarks of Texas Instruments.  
WEBENCH is a registered trademark of Texas Instruments.  
All other trademarks are the property of their respective owners.

## 11.6 Electrostatic Discharge Caution



This integrated circuit can be damaged by ESD. Texas Instruments recommends that all integrated circuits be handled with appropriate precautions. Failure to observe proper handling and installation procedures can cause damage.

ESD damage can range from subtle performance degradation to complete device failure. Precision integrated circuits may be more susceptible to damage because very small parametric changes could cause the device not to meet its published specifications.

## 11.7 Glossary

[SLYZ022](#) — *TI Glossary*.

This glossary lists and explains terms, acronyms, and definitions.

## 12 Mechanical, Packaging, and Orderable Information

The following pages include mechanical packaging and orderable information. This information is the most current data available for the designated devices. This data is subject to change without notice and revision of this document. For browser-based versions of this data sheet, refer to the left-hand navigation.

**PACKAGING INFORMATION**

Orderable Device	Status (1)	Package Type	Package Drawing	Pins	Package Qty	Eco Plan (2)	Lead/Ball Finish (6)	MSL Peak Temp (3)	Op Temp (°C)	Device Marking (4/5)	Samples
TPS54361QDPRRQ1	ACTIVE	WSON	DPR	10	3000	Green (RoHS & no Sb/Br)	CU NIPDAU	Level-2-260C-1 YEAR	-40 to 125	TPS 54361Q	<a href="#">Samples</a>
TPS54361QDPRTQ1	ACTIVE	WSON	DPR	10	250	Green (RoHS & no Sb/Br)	CU NIPDAU	Level-2-260C-1 YEAR	-40 to 125	TPS 54361Q	<a href="#">Samples</a>

(1) The marketing status values are defined as follows:

**ACTIVE:** Product device recommended for new designs.

**LIFEBUY:** TI has announced that the device will be discontinued, and a lifetime-buy period is in effect.

**NRND:** Not recommended for new designs. Device is in production to support existing customers, but TI does not recommend using this part in a new design.

**PREVIEW:** Device has been announced but is not in production. Samples may or may not be available.

**OBSELETE:** TI has discontinued the production of the device.

(2) Eco Plan - The planned eco-friendly classification: Pb-Free (RoHS), Pb-Free (RoHS Exempt), or Green (RoHS & no Sb/Br) - please check <http://www.ti.com/productcontent> for the latest availability information and additional product content details.

**TBD:** The Pb-Free/Green conversion plan has not been defined.

**Pb-Free (RoHS):** TI's terms "Lead-Free" or "Pb-Free" mean semiconductor products that are compatible with the current RoHS requirements for all 6 substances, including the requirement that lead not exceed 0.1% by weight in homogeneous materials. Where designed to be soldered at high temperatures, TI Pb-Free products are suitable for use in specified lead-free processes.

**Pb-Free (RoHS Exempt):** This component has a RoHS exemption for either 1) lead-based flip-chip solder bumps used between the die and package, or 2) lead-based die adhesive used between the die and leadframe. The component is otherwise considered Pb-Free (RoHS compatible) as defined above.

**Green (RoHS & no Sb/Br):** TI defines "Green" to mean Pb-Free (RoHS compatible), and free of Bromine (Br) and Antimony (Sb) based flame retardants (Br or Sb do not exceed 0.1% by weight in homogeneous material)

(3) MSL, Peak Temp. - The Moisture Sensitivity Level rating according to the JEDEC industry standard classifications, and peak solder temperature.

(4) There may be additional marking, which relates to the logo, the lot trace code information, or the environmental category on the device.

(5) Multiple Device Markings will be inside parentheses. Only one Device Marking contained in parentheses and separated by a "~" will appear on a device. If a line is indented then it is a continuation of the previous line and the two combined represent the entire Device Marking for that device.

(6) Lead/Ball Finish - Orderable Devices may have multiple material finish options. Finish options are separated by a vertical ruled line. Lead/Ball Finish values may wrap to two lines if the finish value exceeds the maximum column width.

**Important Information and Disclaimer:** The information provided on this page represents TI's knowledge and belief as of the date that it is provided. TI bases its knowledge and belief on information provided by third parties, and makes no representation or warranty as to the accuracy of such information. Efforts are underway to better integrate information from third parties. TI has taken and continues to take reasonable steps to provide representative and accurate information but may not have conducted destructive testing or chemical analysis on incoming materials and chemicals. TI and TI suppliers consider certain information to be proprietary, and thus CAS numbers and other limited information may not be available for release.

In no event shall TI's liability arising out of such information exceed the total purchase price of the TI part(s) at issue in this document sold by TI to Customer on an annual basis.

**OTHER QUALIFIED VERSIONS OF TPS54361-Q1 :**

- Catalog: [TPS54361](#)

**NOTE: Qualified Version Definitions:**

- Catalog - TI's standard catalog product

## TAPE AND REEL INFORMATION



### QUADRANT ASSIGNMENTS FOR PIN 1 ORIENTATION IN TAPE



\*All dimensions are nominal

Device	Package Type	Package Drawing	Pins	SPQ	Reel Diameter (mm)	Reel Width W1 (mm)	A0 (mm)	B0 (mm)	K0 (mm)	P1 (mm)	W (mm)	Pin1 Quadrant
TPS54361QDP RRQ1	WSON	DPR	10	3000	330.0	12.4	4.25	4.25	1.15	8.0	12.0	Q2
TPS54361QDP RTQ1	WSON	DPR	10	250	180.0	12.4	4.25	4.25	1.15	8.0	12.0	Q2

**TAPE AND REEL BOX DIMENSIONS**

\*All dimensions are nominal

Device	Package Type	Package Drawing	Pins	SPQ	Length (mm)	Width (mm)	Height (mm)
TPS54361QDPRRQ1	WSON	DPR	10	3000	367.0	367.0	35.0
TPS54361QDPRTQ1	WSON	DPR	10	250	210.0	185.0	35.0

DPR (S-PWSON-N10)

PLASTIC SMALL OUTLINE NO-LEAD

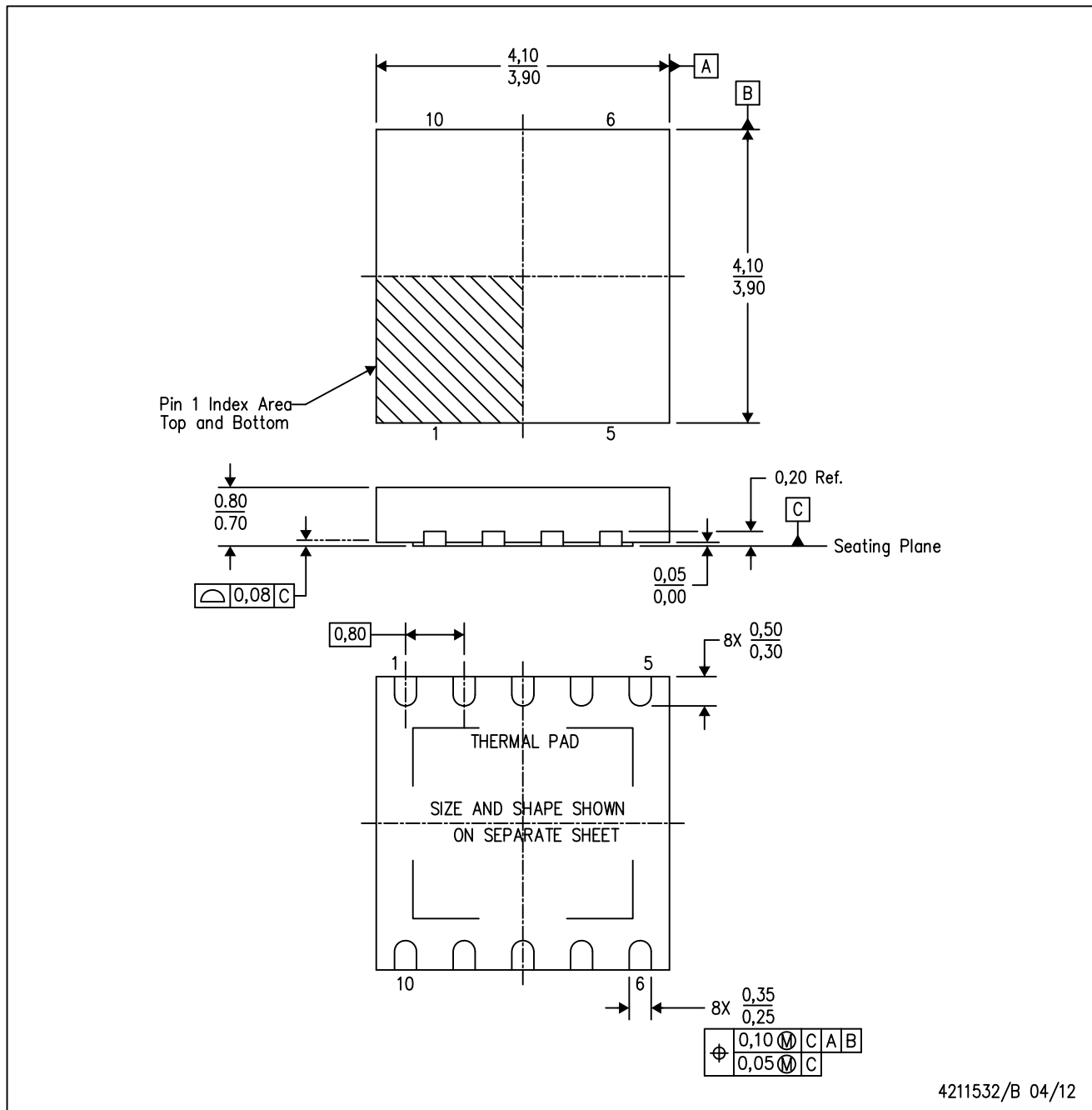

4211532/B 04/12

- NOTES:
- A. All linear dimensions are in millimeters. Dimensioning and tolerancing per ASME Y14.5M-1994.
  - B. This drawing is subject to change without notice.
  - C. SON (Small Outline No-Lead) package configuration.
  - D. The package thermal pad must be soldered to the board for thermal and mechanical performance.
  - E. See the additional figure in the Product Data Sheet for details regarding the exposed thermal pad features and dimensions.

## THERMAL PAD MECHANICAL DATA

DPR (S-PWSON-N10)

PLASTIC SMALL OUTLINE NO-LEAD

### THERMAL INFORMATION

This package incorporates an exposed thermal pad that is designed to be attached directly to an external heatsink. The thermal pad must be soldered directly to the printed circuit board (PCB). After soldering, the PCB can be used as a heatsink. In addition, through the use of thermal vias, the thermal pad can be attached directly to the appropriate copper plane shown in the electrical schematic for the device, or alternatively, can be attached to a special heatsink structure designed into the PCB. This design optimizes the heat transfer from the integrated circuit (IC).

For information on the Quad Flatpack No-Lead (QFN) package and its advantages, refer to Application Report, QFN/SON PCB Attachment, Texas Instruments Literature No. SLUA271. This document is available at [www.ti.com](http://www.ti.com).

The exposed thermal pad dimensions for this package are shown in the following illustration.

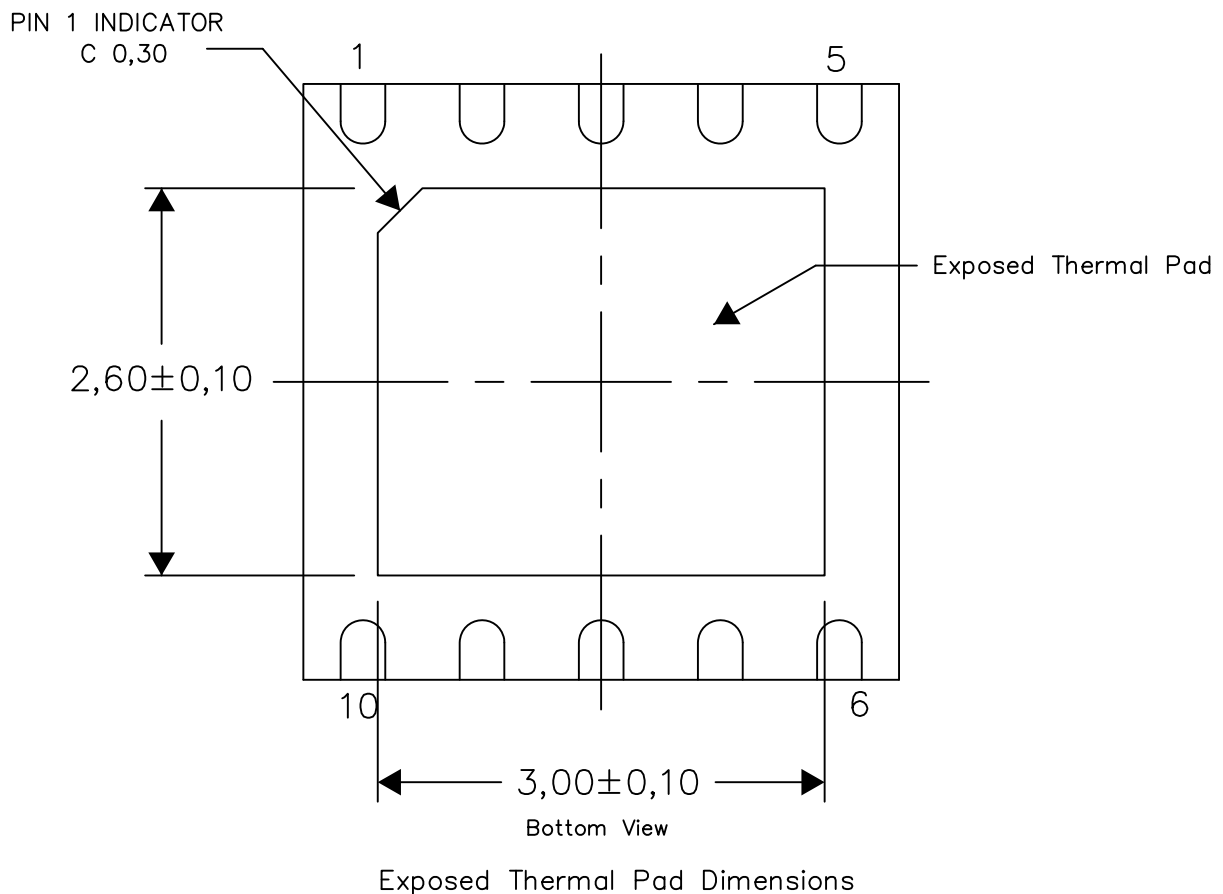

4211551/C 12/13

NOTES: All linear dimensions are in millimeters

DPR (S-PWSON-N10)

PLASTIC SMALL OUTLINE NO-LEAD

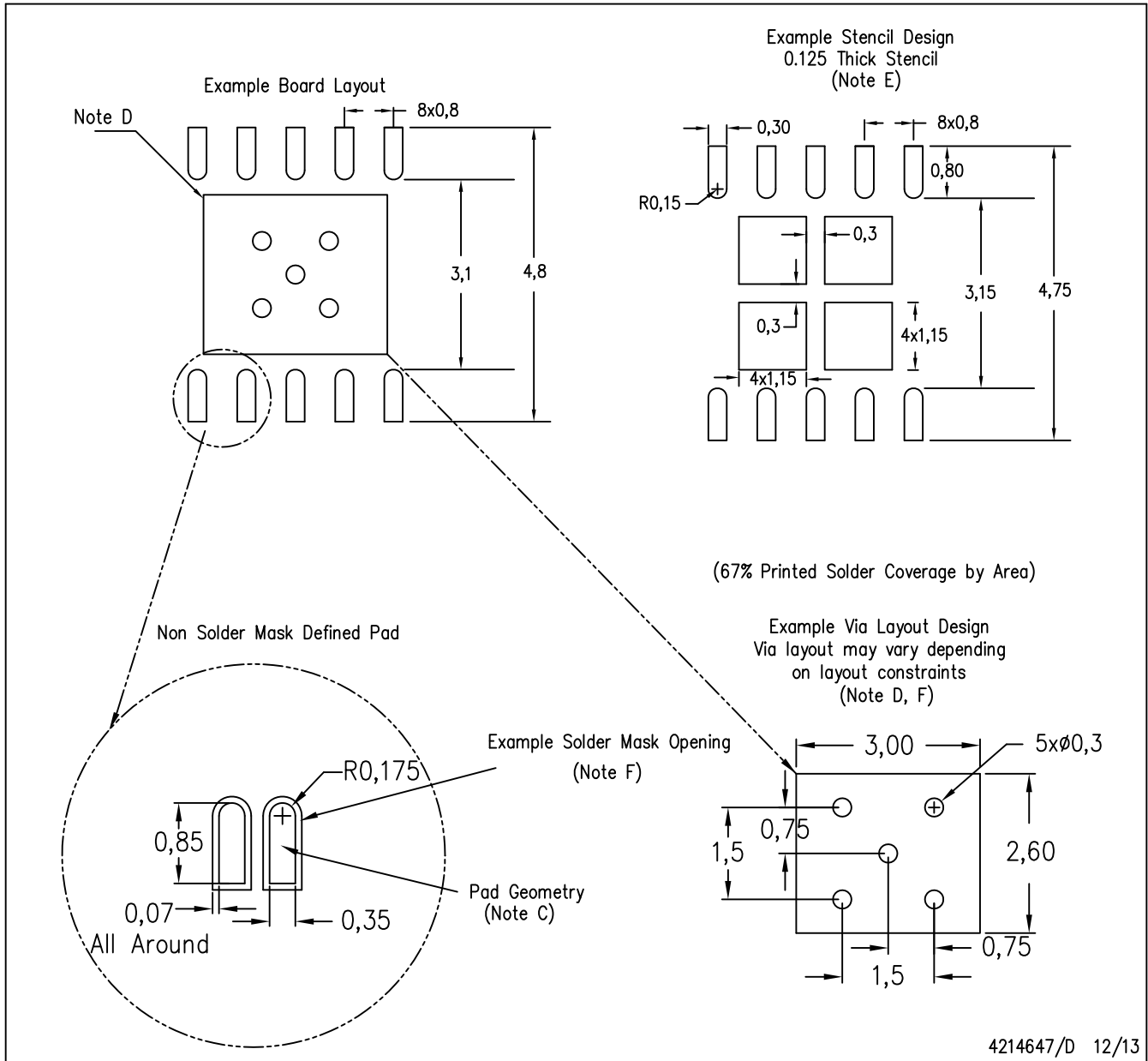

- NOTES:
- All linear dimensions are in millimeters.
  - This drawing is subject to change without notice.
  - Publication IPC-7351 is recommended for alternate designs.
  - This package is designed to be soldered to a thermal pad on the board. Refer to Application Note, Quad Flat-Pack Packages, Texas Instruments Literature No. SLUA271, and also the Product Data Sheets for specific thermal information, via requirements, and recommended board layout. These documents are available at [www.ti.com](http://www.ti.com) <<http://www.ti.com>>.
  - Laser cutting apertures with trapezoidal walls and also rounding corners will offer better paste release. Customers should contact their board assembly site for stencil design recommendations. Refer to IPC 7525 for stencil design considerations.
  - Customers should contact their board fabrication site for recommended solder mask tolerances and via tenting recommendations for vias placed in the thermal pad.

## IMPORTANT NOTICE

Texas Instruments Incorporated (TI) reserves the right to make corrections, enhancements, improvements and other changes to its semiconductor products and services per JESD46, latest issue, and to discontinue any product or service per JESD48, latest issue. Buyers should obtain the latest relevant information before placing orders and should verify that such information is current and complete.

TI's published terms of sale for semiconductor products (<http://www.ti.com/sc/docs/stdterms.htm>) apply to the sale of packaged integrated circuit products that TI has qualified and released to market. Additional terms may apply to the use or sale of other types of TI products and services.

Reproduction of significant portions of TI information in TI data sheets is permissible only if reproduction is without alteration and is accompanied by all associated warranties, conditions, limitations, and notices. TI is not responsible or liable for such reproduced documentation. Information of third parties may be subject to additional restrictions. Resale of TI products or services with statements different from or beyond the parameters stated by TI for that product or service voids all express and any implied warranties for the associated TI product or service and is an unfair and deceptive business practice. TI is not responsible or liable for any such statements.

Buyers and others who are developing systems that incorporate TI products (collectively, "Designers") understand and agree that Designers remain responsible for using their independent analysis, evaluation and judgment in designing their applications and that Designers have full and exclusive responsibility to assure the safety of Designers' applications and compliance of their applications (and of all TI products used in or for Designers' applications) with all applicable regulations, laws and other applicable requirements. Designer represents that, with respect to their applications, Designer has all the necessary expertise to create and implement safeguards that (1) anticipate dangerous consequences of failures, (2) monitor failures and their consequences, and (3) lessen the likelihood of failures that might cause harm and take appropriate actions. Designer agrees that prior to using or distributing any applications that include TI products, Designer will thoroughly test such applications and the functionality of such TI products as used in such applications.

TI's provision of technical, application or other design advice, quality characterization, reliability data or other services or information, including, but not limited to, reference designs and materials relating to evaluation modules, (collectively, "TI Resources") are intended to assist designers who are developing applications that incorporate TI products; by downloading, accessing or using TI Resources in any way, Designer (individually or, if Designer is acting on behalf of a company, Designer's company) agrees to use any particular TI Resource solely for this purpose and subject to the terms of this Notice.

TI's provision of TI Resources does not expand or otherwise alter TI's applicable published warranties or warranty disclaimers for TI products, and no additional obligations or liabilities arise from TI providing such TI Resources. TI reserves the right to make corrections, enhancements, improvements and other changes to its TI Resources. TI has not conducted any testing other than that specifically described in the published documentation for a particular TI Resource.

Designer is authorized to use, copy and modify any individual TI Resource only in connection with the development of applications that include the TI product(s) identified in such TI Resource. NO OTHER LICENSE, EXPRESS OR IMPLIED, BY ESTOPPEL OR OTHERWISE TO ANY OTHER TI INTELLECTUAL PROPERTY RIGHT, AND NO LICENSE TO ANY TECHNOLOGY OR INTELLECTUAL PROPERTY RIGHT OF TI OR ANY THIRD PARTY IS GRANTED HEREIN, including but not limited to any patent right, copyright, mask work right, or other intellectual property right relating to any combination, machine, or process in which TI products or services are used. Information regarding or referencing third-party products or services does not constitute a license to use such products or services, or a warranty or endorsement thereof. Use of TI Resources may require a license from a third party under the patents or other intellectual property of the third party, or a license from TI under the patents or other intellectual property of TI.

TI RESOURCES ARE PROVIDED "AS IS" AND WITH ALL FAULTS. TI DISCLAIMS ALL OTHER WARRANTIES OR REPRESENTATIONS, EXPRESS OR IMPLIED, REGARDING RESOURCES OR USE THEREOF, INCLUDING BUT NOT LIMITED TO ACCURACY OR COMPLETENESS, TITLE, ANY EPIDEMIC FAILURE WARRANTY AND ANY IMPLIED WARRANTIES OF MERCHANTABILITY, FITNESS FOR A PARTICULAR PURPOSE, AND NON-INFRINGEMENT OF ANY THIRD PARTY INTELLECTUAL PROPERTY RIGHTS. TI SHALL NOT BE LIABLE FOR AND SHALL NOT DEFEND OR INDEMNIFY DESIGNER AGAINST ANY CLAIM, INCLUDING BUT NOT LIMITED TO ANY INFRINGEMENT CLAIM THAT RELATES TO OR IS BASED ON ANY COMBINATION OF PRODUCTS EVEN IF DESCRIBED IN TI RESOURCES OR OTHERWISE. IN NO EVENT SHALL TI BE LIABLE FOR ANY ACTUAL, DIRECT, SPECIAL, COLLATERAL, INDIRECT, PUNITIVE, INCIDENTAL, CONSEQUENTIAL OR EXEMPLARY DAMAGES IN CONNECTION WITH OR ARISING OUT OF TI RESOURCES OR USE THEREOF, AND REGARDLESS OF WHETHER TI HAS BEEN ADVISED OF THE POSSIBILITY OF SUCH DAMAGES.

Unless TI has explicitly designated an individual product as meeting the requirements of a particular industry standard (e.g., ISO/TS 16949 and ISO 26262), TI is not responsible for any failure to meet such industry standard requirements.

Where TI specifically promotes products as facilitating functional safety or as compliant with industry functional safety standards, such products are intended to help enable customers to design and create their own applications that meet applicable functional safety standards and requirements. Using products in an application does not by itself establish any safety features in the application. Designers must ensure compliance with safety-related requirements and standards applicable to their applications. Designer may not use any TI products in life-critical medical equipment unless authorized officers of the parties have executed a special contract specifically governing such use. Life-critical medical equipment is medical equipment where failure of such equipment would cause serious bodily injury or death (e.g., life support, pacemakers, defibrillators, heart pumps, neurostimulators, and implantables). Such equipment includes, without limitation, all medical devices identified by the U.S. Food and Drug Administration as Class III devices and equivalent classifications outside the U.S.

TI may expressly designate certain products as completing a particular qualification (e.g., Q100, Military Grade, or Enhanced Product). Designers agree that it has the necessary expertise to select the product with the appropriate qualification designation for their applications and that proper product selection is at Designers' own risk. Designers are solely responsible for compliance with all legal and regulatory requirements in connection with such selection.

Designer will fully indemnify TI and its representatives against any damages, costs, losses, and/or liabilities arising out of Designer's non-compliance with the terms and provisions of this Notice.

## Looking for pricing, stock, or lifecycle information?

Click below to explore more details on WIN SOURCE:

 [View TPS54361QDPRTQ1 on WIN SOURCE](#)

 [Texas Instruments](#) Information

## Optimize Your Supply Chain with WIN SOURCE Solutions

-  Global Sourcing Solution
-  Obsolete Management
-  Cost Control Management
-  Shortage Management
-  Alternative Solution
-  Excess Inventory Management