



THE DATASHEET OF STEVAL-ILL016V2





TSM1052

Constant voltage and constant current controller for battery chargers and adapters

Features

- Secondary-side constant voltage and constant current control
- Very low voltage operation
- Very low quiescent consumption
- High-accuracy internal reference
- Low external component count
- Wired-or open-drain output stage
- Easy frequency compensation
- SOT23-6 micro package

Applications

- Battery chargers
- AC DC adapters

Description

The TSM1052 is a highly integrated solution for SMPS applications requiring a dual control loop to perform CV (constant voltage) and CC (constant current) regulation.

The TSM1052 integrates a voltage reference, two op amps (with OR-ed open-drain outputs), and a low-side current sensing circuit.

The voltage reference, along with one op amp, is the core of the voltage control loop; the current sensing circuit and the other op amp make up the current control loop.

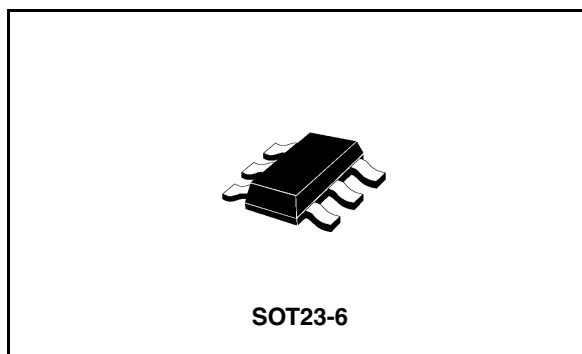

The external components needed to complete the two control loops are:

- A resistor divider that senses the output of the power supply (adapter, battery charger) and fixes the voltage regulation set point at the specified value;
- A sense resistor that feeds the current sensing circuit with a voltage proportional to the dc output current; this resistor determines the current regulation set point and must be adequately rated in terms of power dissipation;
- Frequency compensation components (RC networks) for both loops.

The TSM1052, housed in one of the smallest package available, is ideal for space-shrunk applications such as adapters and chargers.

Table 1. Device summary

Part number	Package	Packaging
TSM1052	SOT23-6	Tape and reel

Contents

1	Description	3
1.1	Pin connection	3
1.2	Pin description	3
1.3	Internal schematic	4
1.4	Absolute maximum ratings	4
1.5	Thermal data	4
2	Electrical characteristics	5
3	Typical characteristics	6
4	Application information	8
4.1	Typical application schematic	8
4.2	Voltage and current control	8
4.2.1	Voltage control	8
4.2.2	Current control	9
4.3	Compensation	10
4.4	Start up and short circuit conditions	10
5	Mechanical data	12
6	Revision history	14

1 Description

1.1 Pin connection

Figure 1. Pin Connection (top view)

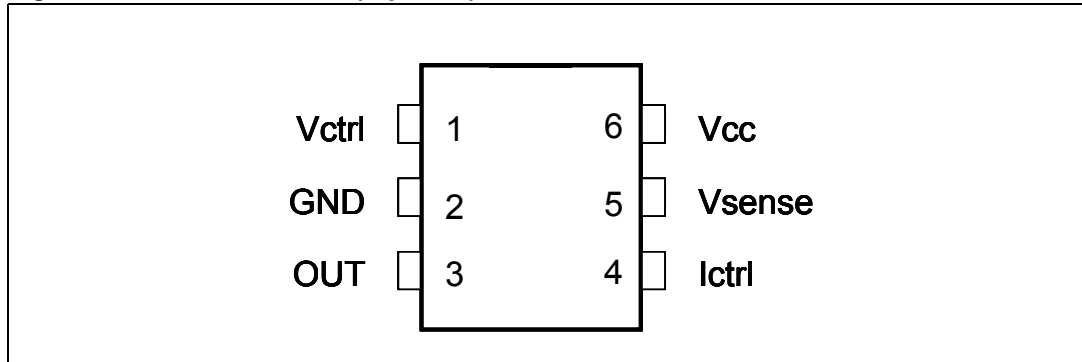

1.2 Pin description

Table 2. Pin description

N.	Name	Function
1	V_{ctrl}	Inverting input of the voltage loop op amp. The pin will be tied to the mid-point of a resistor divider that senses the output voltage.
2	GND	Ground. Return of the bias current of the device. 0 V reference for all voltages. The pin should be tied as close to the ground output terminal of the converter as possible to minimize load current effect on the voltage regulation set point.
3	OUT	Common open-drain output of the two internal op amps. The pin, able to sink current only, will be connected to the branch of the optocoupler's photodiode to transmit the error signal to the primary side.
4	I_{ctrl}	Non-inverting input of the current loop op amp. It will be tied directly to the hot (negative) end of the current sense resistor
5	V_{sense}	Inverting input of the current loop op amp. The pin will be tied to the cold end of the current sense resistor through a decoupling resistor.
6	Vcc	Supply Voltage of the device. A small bypass capacitor (0.1 μ F typ.) to GND, located as close to IC's pins as possible, might be useful to get a clean supply voltage.

1.3 Internal schematic

Figure 2. Internal schematic

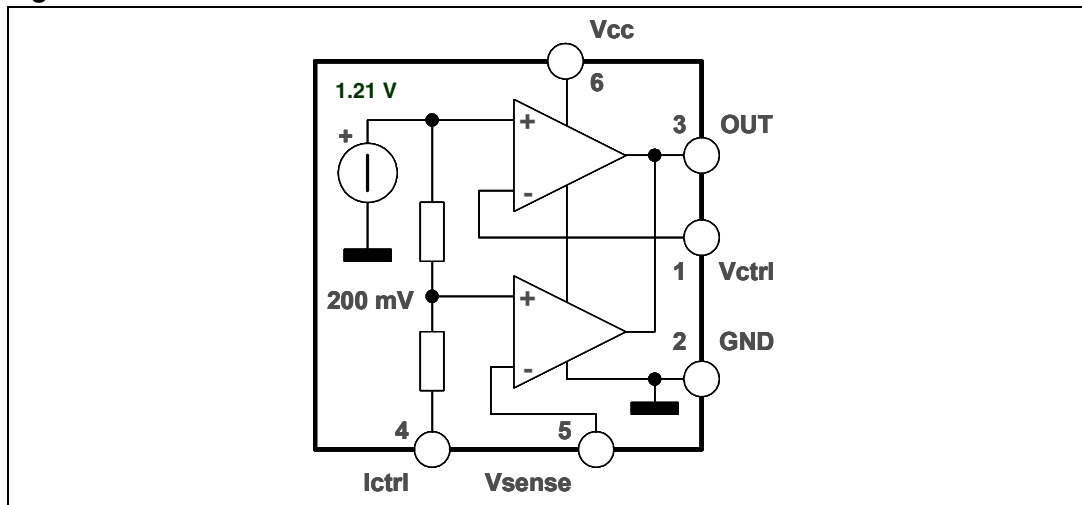

1.4 Absolute maximum ratings

Table 3. Absolute maximum ratings

Symbol	Pin	Parameter	Value	Unit
V_{CC}	6	DC supply voltage	-0.3 to 20	V
V_{OUT}	3	Open-drain voltage	-0.3 to V_{CC}	V
I_{OUT}	3	Max sink current	100	mA
V	1, 4, 5	Analog inputs	-0.3 to 3.3	V

1.5 Thermal data

Table 4. Thermal data

Symbol	Parameter	Value	Unit
R_{thJA}	Thermal resistance, junction-to-ambient	250	°C/W
T_{OP}	Junction temperature operating range	-10 to 85	°C
T_{Jmax}	Maximum junction temperature	150	
T_{STG}	Storage temperature	-55 to 150	

2 Electrical characteristics

$T_J = 25\text{ °C}$ and $V_{CC} = 5\text{ V}$, unless otherwise specified

Table 5. Electrical characteristics

Symbol	Parameter	Test conditions	Min	Typ	Max	Unit
Device supply						
V_{CC}	Voltage operating range		1.7		18	V
I_{CC}	Quiescent current ($I_{ctrl} = V_{sense} = V_{ctr} = 0$, OUT = open)			150		μA
		(1)			300	
Voltage control loop op amp						
G_{m_v}	Transconductance (sink current only) ⁽²⁾		1	3.5		S
		(1)		2.5		
V_{ref}	Voltage reference ⁽³⁾		1.198	1.21	1.222	V
		(1)	1.186		1.234	
I_{bias}	Inverting input bias current			50		nA
		(1)		100		
Current control loop						
G_{m_i}	Transconductance (sink current only) ⁽⁴⁾		1.5	7		S
		(1)				
V_{sense}	Current loop reference ⁽⁵⁾ @ $I_{(out)} = 1\text{ mA}$		196	200	204	mV
		(1)	192		208	
I_{bias}	Non-inverting input source current @ $V(I_{ctrl}) = -200\text{ mV}$			20		μA
		(1)		40		
Output stage						
V_{OUTlow}	Low output level @ 2 mA sink current			100		mV
		(1)			200	

1. Specification referred to $-10\text{ °C} < T_A < 85\text{ °C}$
2. If the voltage on V_{ctrl} (the negative input of the amplifier) is higher than the positive amplifier input ($V_{ref} = 1.21\text{ V}$), and it is increased by 1mV, the sinking current at the output OUT will be increased by 3.5 mA.
3. The internal Voltage Reference is set at 1.21 V (bandgap reference). The voltage control loop precision takes into account the cumulative effects of the internal voltage reference deviation as well as the input offset voltage of the transconductance operational amplifier. The internal Voltage Reference is fixed by bandgap, and trimmed to 0.5% accuracy at room temperature.
4. When the positive input at I_{ctrl} is lower than -200 mV, and the voltage is decreased by 1mV, the sinking current at the output Out will be increased by 7 mA.
5. The internal current sense threshold is set at -200 mV. The current control loop precision takes into account the cumulative effects of the internal voltage reference deviation as well as the input offset voltage of the transconductance operational amplifier.

3 Typical characteristics

Figure 3. V_{ref} vs ambient temperature

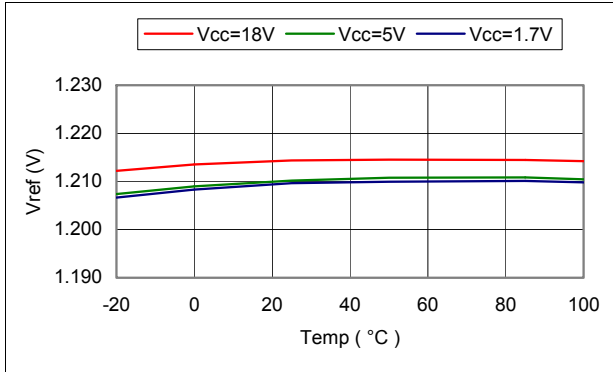

Figure 4. V_{SENSE} vs ambient temperature

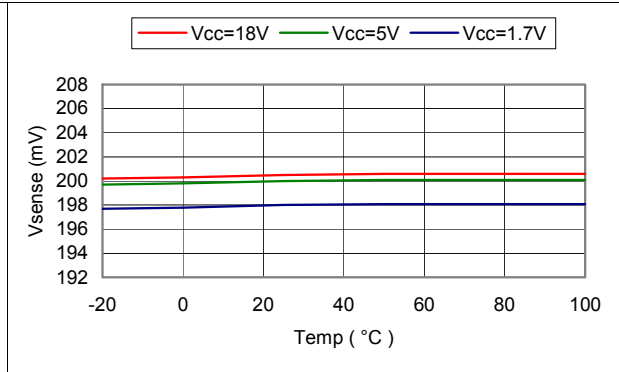

Figure 5. V_{SENSE} pin input bias current vs ambient temperature

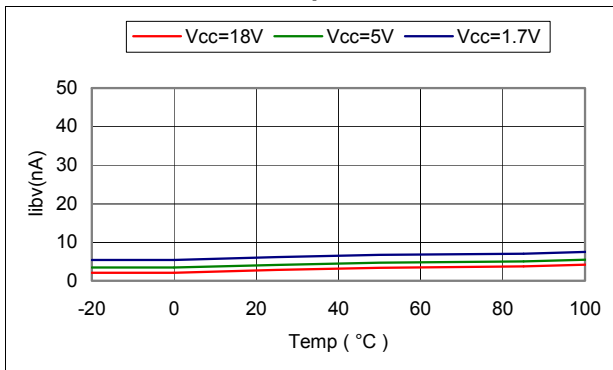

Figure 6. I_{CTRL} pin input bias current vs ambient temperature

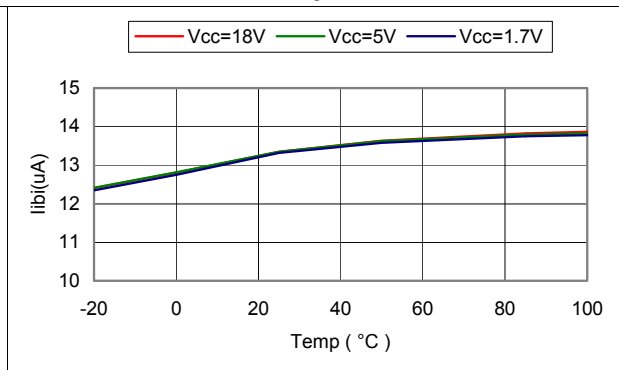

Figure 7. Transconductances (sink current only) of voltage control loop op amp vs ambient temperature

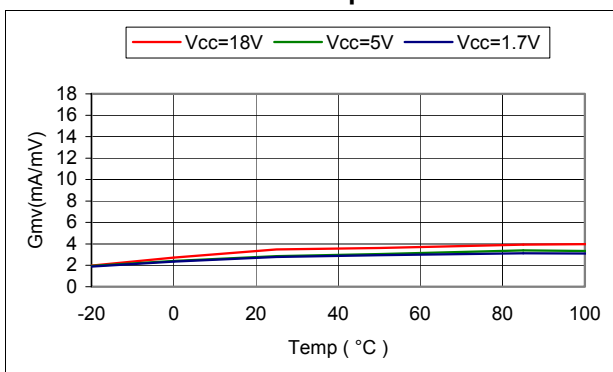

Figure 8. Transconductance (sink current only) of current control loop op amp vs ambient temperature

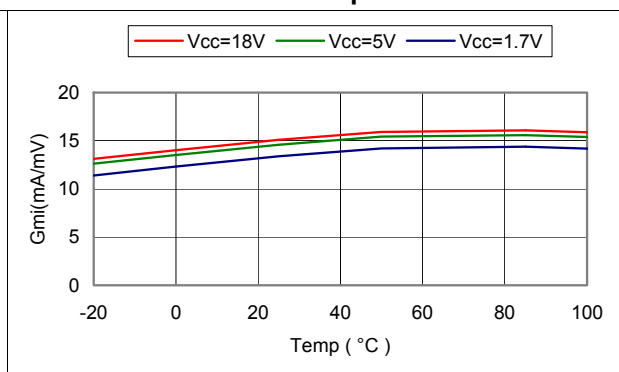

Figure 9. Low output level of voltage control loop op amp vs ambient temperature (2 mA sink current)

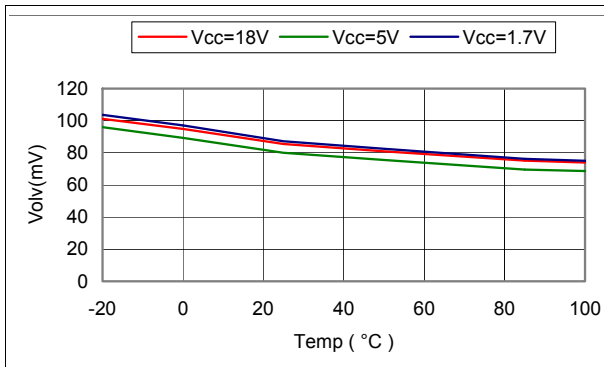

Figure 10. Low output level of current control loop op amp vs ambient temperature (2 mA sink current)

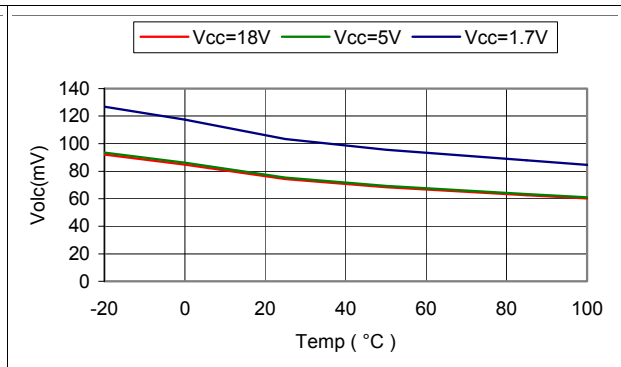

Figure 11. Output short circuit current of voltage control loop op amp vs ambient temperature

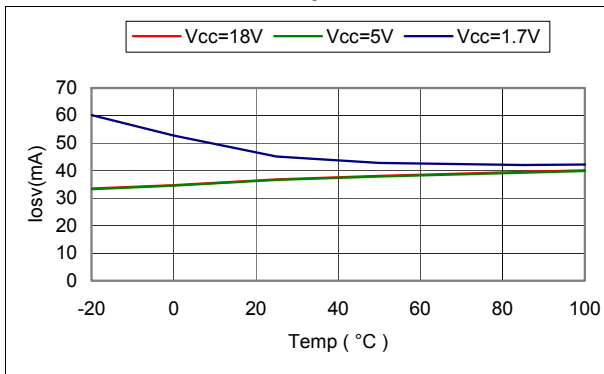

Figure 12. Output short circuit current of current control loop op amp vs ambient temperature

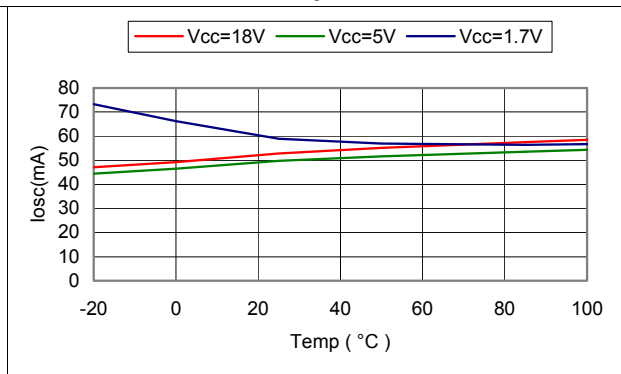

Figure 13. Supply current vs ambient temperature

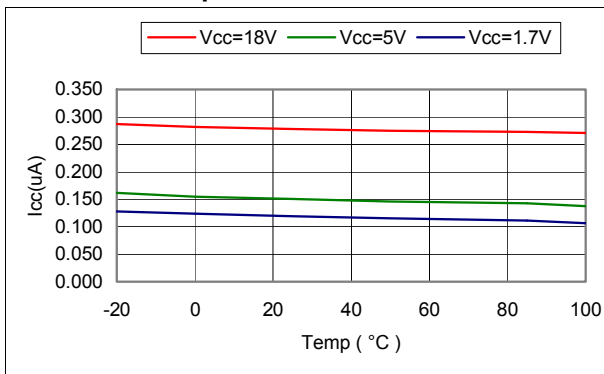
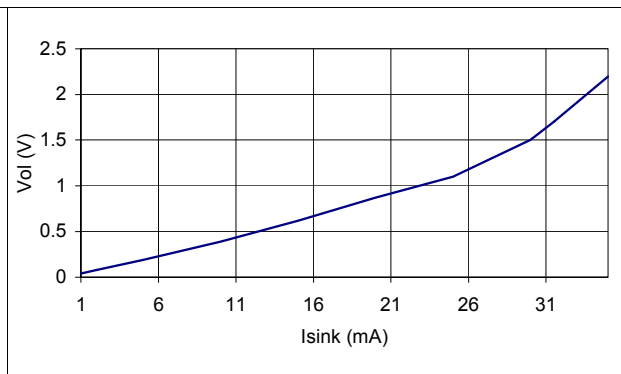

Figure 14. Low output level vs sink current



4 Application information

4.1 Typical application schematic

Figure 15. Typical adapter or battery charger application using the device

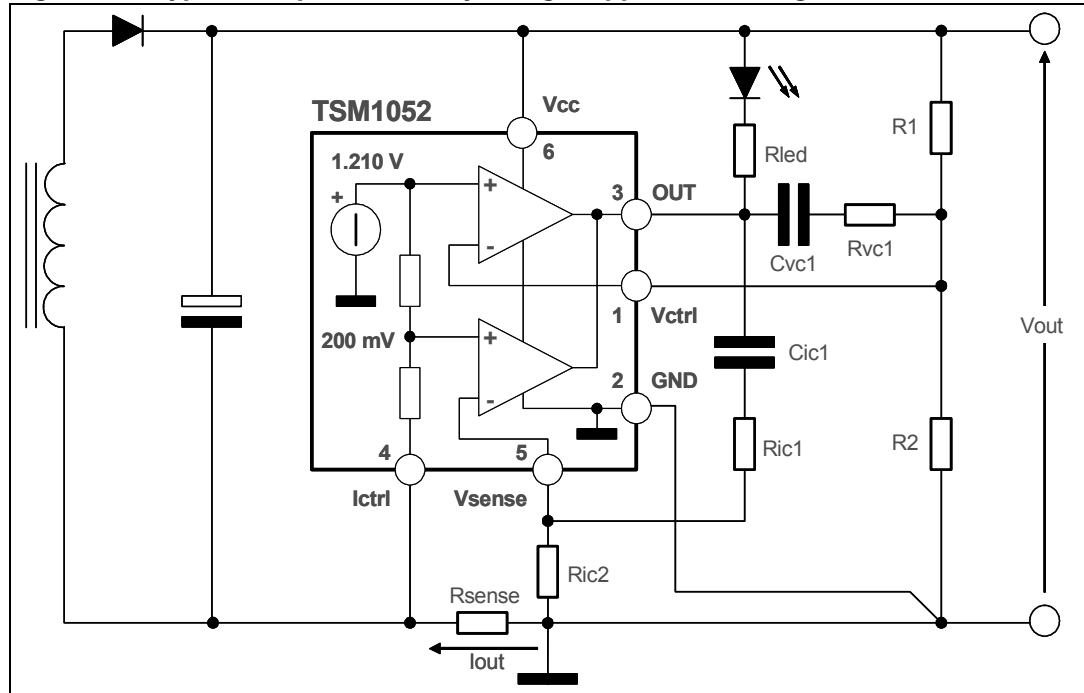

In the above application schematic, the device is used on the secondary side of a flyback adapter (or battery charger) to provide an accurate control of voltage and current. The above feedback loop is made with an optocoupler.

4.2 Voltage and current control

4.2.1 Voltage control

The voltage loop is controlled via a first transconductance operational amplifier, the voltage divider R_1 , R_2 , and the optocoupler which is directly connected to the output. Its possible to choose the values of R_1 and R_2 resistors using Equation 1:

Equation 1

$$a) \quad V_{out} = V_{ref} \cdot \frac{(R_1 + R_2)}{R_2}$$

$$b) \quad R_1 = R_2 \cdot \frac{(V_{out} - V_{ref})}{V_{ref}}$$

where V_{out} is the desired output voltage.

As an example, with $R_1 = 100 \text{ k}\Omega$ and $R_2 = 27 \text{ k}\Omega$, $V_{OUT} = 5.7 \text{ V}$

4.2.2 Current control

The current loop is controlled via the second trans-conductance operational amplifier, the sense resistor R_{sense} , and the optocoupler. The control equation verifies:

Equation 2

$$\begin{aligned} \text{a)} \quad & R_{sense} \cdot I_{lim} = V_{sense} \\ \text{b)} \quad & R_{sense} = \frac{V_{sense}}{I_{lim}} \end{aligned}$$

where I_{lim} is the desired limited current, and V_{SENSE} is the threshold voltage for the current control loop.

As an example, with $I_{lim} = 1 \text{ A}$, $V_{SENSE} = 200 \text{ mV}$, then $R_{SENSE} = 200 \text{ m}\Omega$.

Note: The R_{sense} resistor should be chosen taking into account the maximum dissipation (P_{lim}) through it during full load operation.

Equation 3

$$P_{lim} = V_{sense} \cdot I_{lim}$$

As an example, with $I_{lim} = 1 \text{ A}$, and $V_{sense} = 200 \text{ mV}$, $P_{lim} = 200 \text{ mW}$.

Therefore, for most adapter and battery charger applications, a quarter-watt, or half-watt resistor is sufficient. V_{SENSE} threshold is made internally by a voltage divider tied to the V_{ref} voltage reference. Its middle point is tied to the positive input of the current control operational amplifier, and its foot is to be connected to lower potential point of the sense resistor as shown in [Figure 15 on page 8](#). The resistors of this voltage divider are matched to provide the best possible accuracy. The current sinking outputs of the two transconductance operational amplifiers are common (to the output of the IC). This makes an ORing function which ensures either the voltage control or the current control, driving the optocoupler's photodiode to transmit the feedback to the primary side.

The relation between the controlled current and the controlled output voltage can be described with a square characteristic as shown in the following V/I output-power diagram. (with the power supply of the device independent of the output voltage)

Figure 16. Output voltage versus output current

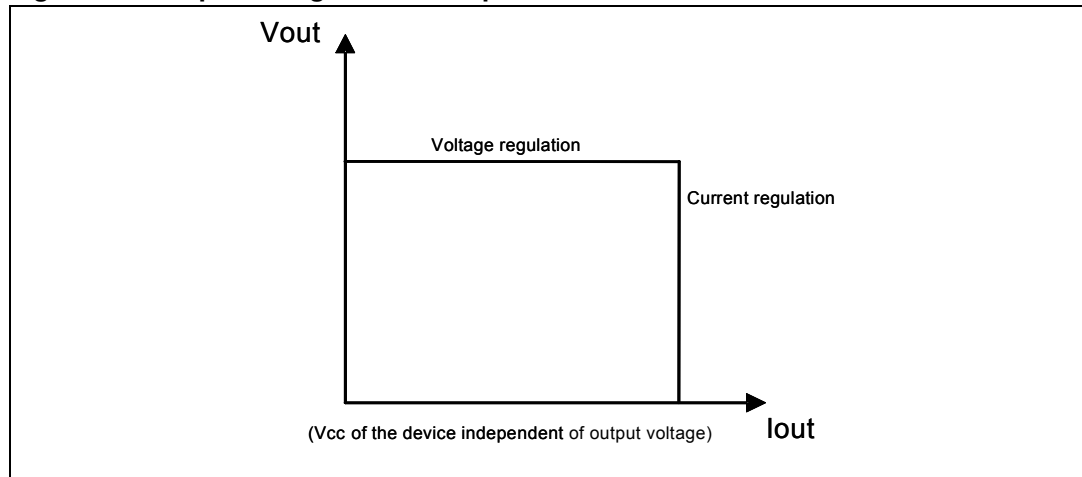

4.3 Compensation

The voltage control transconductance operational amplifier can be fully compensated. Both of its output and negative input are directly accessible for external compensation components.

An example of a suitable compensation network is shown in [Figure 15](#). It consists of a capacitor $C_{VC1} = 2.2 \text{ nF}$ and a resistor $R_{CV1} = 470 \text{ k}\Omega$ in series.

The current-control transconductance operational amplifier can be fully compensated. Both its output and negative input are directly accessible for external compensation components. An example of a suitable compensation network is shown in [Figure 15](#). It consists of a capacitor $C_{IC1} = 2.2 \text{ nF}$ and a resistor $R_{IC1} = 22 \text{ k}\Omega$ in series. In order to increase the stability of the application it is suggested to add a resistor in series with the optocoupler. An example of a suitable R_{LED} value could be $330 \text{ }\Omega$ in series with the optocoupler.

4.4 Start up and short circuit conditions

Under start-up or short-circuit conditions if the device is supplied from SMPS output and the output voltage is lower than V_{cc} minimum the current regulation is not guaranteed.

Therefore, the current limitation can only be ensured by the primary PWM module, which should be chosen accordingly.

If the primary current limitation is considered not to be precise enough for the application, then a sufficient supply for the device has to be ensured under any condition. It would then be necessary to add some circuitry to supply the chip with a separate power line. This can be achieved in numerous ways, including an additional winding on the transformer.

The following schematic shows how to realize a low-cost power supply for the device (with no additional windings).

Figure 17. Application circuit able to supply the device even with $V_{OUT} = 0$

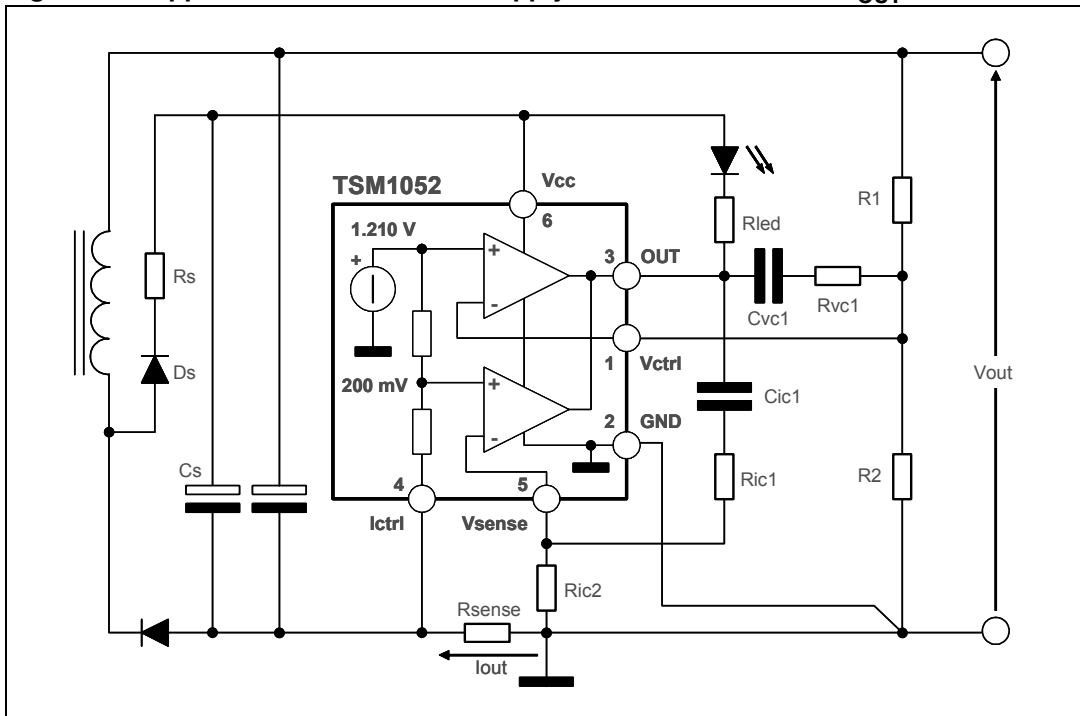

5 Package mechanical data

In order to meet environmental requirements, ST offers these devices in ECOPACK® packages. These packages have a Lead-free second level interconnect. The category of second Level Interconnect is marked on the package and on the inner box label, in compliance with JEDEC Standard JESD97. The maximum ratings related to soldering conditions are also marked on the inner box label. ECOPACK is an ST trademark. ECOPACK specifications are available at: www.st.com.

Table 6. SOT23-6 mechanical data

Dim.	mm.			inch		
	Min	Typ	Max	Min	Typ	Max
A		0.9	1.45		0.035	0.057
A1		0	0.1		0	0.0039
A2		0.9	1.3		0.035	0.0512
b		0.35	0.5		0.014	0.02
c		0.09	0.2		0.004	0.008
D		2.8	3.05		0.11	0.120
E		1.5	1.75		0.059	0.0689
e	0.95			0.037		
H		2.6	3		0.102	0.118
L		0.1	0.6		0.004	0.024
θ		0	10°		0	10°

Note: Dimensions per JEDEC MO178AB

Figure 18. Package dimensions

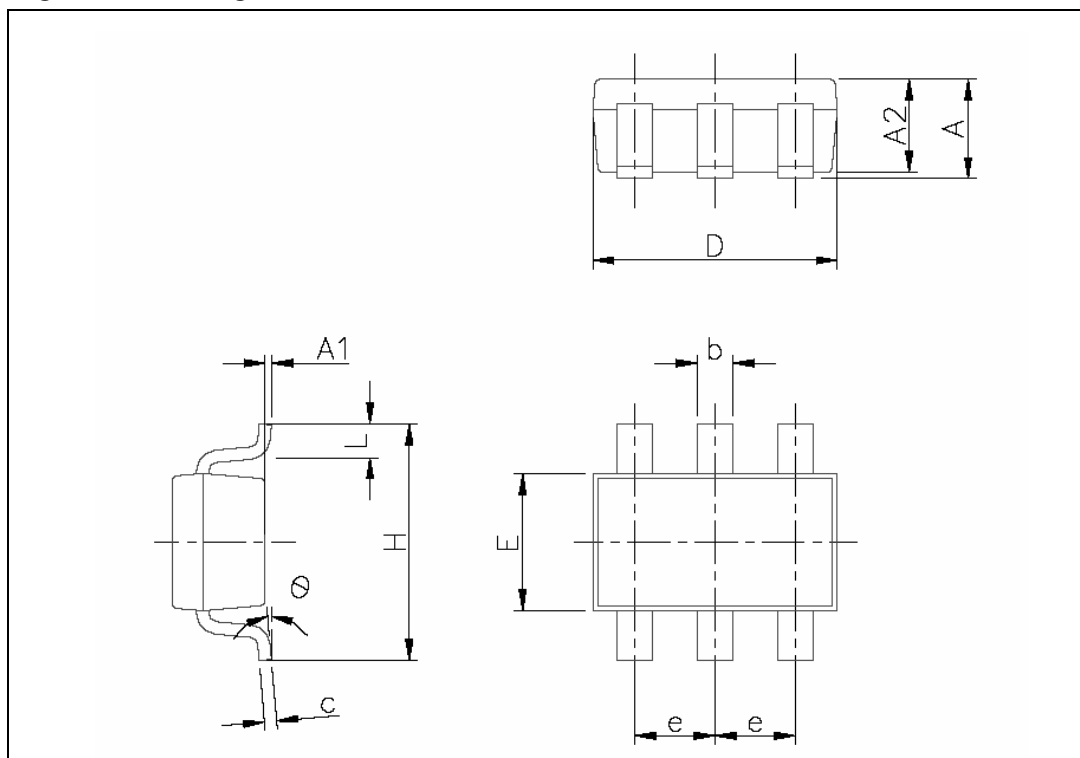

6 Revision history

Table 7. Document revision history

Date	Revision	Changes
20-Feb-2007	1	Initial release.
07-Feb-2008	2	Updated: Section 5 on page 12

Please Read Carefully:

Information in this document is provided solely in connection with ST products. STMicroelectronics NV and its subsidiaries ("ST") reserve the right to make changes, corrections, modifications or improvements, to this document, and the products and services described herein at any time, without notice.

All ST products are sold pursuant to ST's terms and conditions of sale.

Purchasers are solely responsible for the choice, selection and use of the ST products and services described herein, and ST assumes no liability whatsoever relating to the choice, selection or use of the ST products and services described herein.

No license, express or implied, by estoppel or otherwise, to any intellectual property rights is granted under this document. If any part of this document refers to any third party products or services it shall not be deemed a license grant by ST for the use of such third party products or services, or any intellectual property contained therein or considered as a warranty covering the use in any manner whatsoever of such third party products or services or any intellectual property contained therein.

UNLESS OTHERWISE SET FORTH IN ST'S TERMS AND CONDITIONS OF SALE ST DISCLAIMS ANY EXPRESS OR IMPLIED WARRANTY WITH RESPECT TO THE USE AND/OR SALE OF ST PRODUCTS INCLUDING WITHOUT LIMITATION IMPLIED WARRANTIES OF MERCHANTABILITY, FITNESS FOR A PARTICULAR PURPOSE (AND THEIR EQUIVALENTS UNDER THE LAWS OF ANY JURISDICTION), OR INFRINGEMENT OF ANY PATENT, COPYRIGHT OR OTHER INTELLECTUAL PROPERTY RIGHT.

UNLESS EXPRESSLY APPROVED IN WRITING BY AN AUTHORIZED ST REPRESENTATIVE, ST PRODUCTS ARE NOT RECOMMENDED, AUTHORIZED OR WARRANTED FOR USE IN MILITARY, AIR CRAFT, SPACE, LIFE SAVING, OR LIFE SUSTAINING APPLICATIONS, NOR IN PRODUCTS OR SYSTEMS WHERE FAILURE OR MALFUNCTION MAY RESULT IN PERSONAL INJURY, DEATH, OR SEVERE PROPERTY OR ENVIRONMENTAL DAMAGE. ST PRODUCTS WHICH ARE NOT SPECIFIED AS "AUTOMOTIVE GRADE" MAY ONLY BE USED IN AUTOMOTIVE APPLICATIONS AT USER'S OWN RISK.

Resale of ST products with provisions different from the statements and/or technical features set forth in this document shall immediately void any warranty granted by ST for the ST product or service described herein and shall not create or extend in any manner whatsoever, any liability of ST.

ST and the ST logo are trademarks or registered trademarks of ST in various countries.

Information in this document supersedes and replaces all information previously supplied.

The ST logo is a registered trademark of STMicroelectronics. All other names are the property of their respective owners.

© 2008 STMicroelectronics - All rights reserved

STMicroelectronics group of companies

Australia - Belgium - Brazil - Canada - China - Czech Republic - Finland - France - Germany - Hong Kong - India - Israel - Italy - Japan - Malaysia - Malta - Morocco - Singapore - Spain - Sweden - Switzerland - United Kingdom - United States of America

www.st.com

Looking for pricing, stock, or lifecycle information?

Click below to explore more details on WIN SOURCE:

- ⊖ [View STEVAL-ILL016V2 on WIN SOURCE](#)
- ⊖ [STMicroelectronics Information](#)

Optimize Your Supply Chain with WIN SOURCE Solutions

- ✓ Global Sourcing Solution
- ✓ Obsolete Management
- ✓ Cost Control Management
- ✓ Shortage Management
- ✓ Alternative Solution
- ✓ Excess Inventory Management