



**THE DATASHEET OF
ST75C176CDR**



Low power RS-485/RS-422 transceiver

Features

- Low quiescent current: 300 mA
- Designed for RS-485 interface applications
- -7 V to 12 V common mode input voltage range
- Driver maintains high impedance in 3-state or with the power OFF
- 70 mV typical input hysteresis
- 30 ns propagation delays, 5 ns skew
- Operate from a single 5 V supply
- Current limiting and thermal shutdown for driver overload protection
- Allows up to 32 transceivers on the bus
- BiCMOS technology

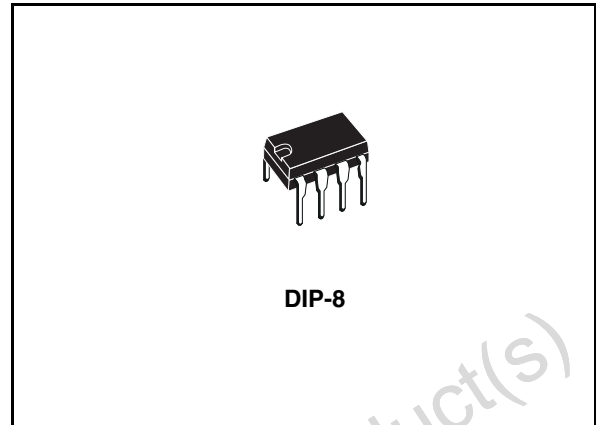

The ST75C176B/C is designed for bidirectional data communications on multipoint bus transmission line (half-duplex applications).

Description

The ST75C176B/C is a low power transceiver for RS-485 and RS-422 communication. Each part contains one driver and one receiver.

This transceiver draws 300 mA (typ.) of supply current when unloaded or fully loaded with disabled drivers.

It operates from a single 5 V supply.

Driver is short-circuit current limited and is protected against excessive power dissipation by thermal shutdown circuitry that places the driver outputs into a high-impedance state. The receiver input has a fail safe feature that guarantees a logic-high output if the input is open circuit.

Table 1. Device summary

Order code	Temperature range	Package	Packaging
ST75C176CN	0 to 70 °C	DIP-8	50parts per tube / 40tube per box
ST75C176BN	-40 to 85 °C	DIP-8	50parts per tube / 40tube per box

Contents

1	Pin configuration	3
2	Truth tables	4
3	Maximum ratings	5
4	Electrical characteristics	6
5	Test circuits and typical characteristics	9
6	Package mechanical data	14
7	Revision history	16

Obsolete Product(s) - Obsolete Product(s)

1 Pin configuration

Figure 1. Pin connections

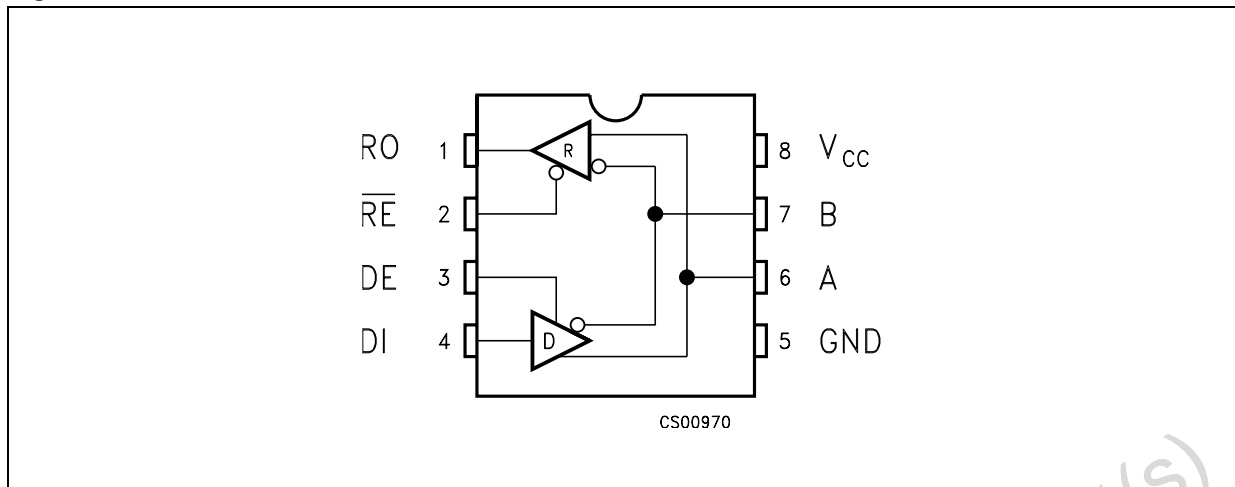

Table 2. Pin description

Pin n°	Symbol	Name and function
1	RO	Receiver output
2	RE	Receiver output enable
3	DE	Driver output enable
4	DI	Driver input
5	GND	Ground
6	A	Non-inverting receiver input and non-inverting driver output
7	B	Inverting receiver input and inverting driver output
8	V _{CC}	Supply voltage

2 Truth tables

Table 3. Truth table (driver)

Inputs			Outputs	
\overline{RE}	DE	DI	B	A
X	H	H	L	H
X	H	L	H	L
X	L	X	Z	Z

Note: X= Don't care; Z=High impedance

Table 4. Truth table (receiver)

Inputs			Output
RE	DE	A-B	RO
L	L	$\geq +0.2V$	H
L	L	$\leq -0.2V$	L
L	L	INPUTS OPEN	H
H	L	X	Z

Note: X= Don't care; Z=High impedance

3 Maximum ratings

Table 5. Absolute maximum ratings

Symbol	Parameter	Value	Unit
V_{CC}	Supply voltage	7	V
V_I	Control input voltage (\overline{RE} , DE)	-0.5 to ($V_{CC} + 0.5$)	V
V_{DI}	Driver input voltage (DI)	-0.5 to ($V_{CC} + 0.5$)	V
V_{DO}	Driver output voltage (A, B)	± 14	V
V_{RI}	Receiver input voltage (A, B)	± 14	V
V_{RO}	Receiver output voltage (RO)	-0.5 to ($V_{CC} + 0.5$)	V

Note: Absolute maximum ratings are those values beyond which damage to the device may occur. Functional operation under these condition is not implied.

4 Electrical characteristics

Table 6. DC electrical characteristics

($V_{CC} = 5\text{ V} \pm 5\%$, $T_A = T_{MIN}$ to T_{MAX} , unless otherwise specified. Typical values are referred to $T_A = 25\text{ }^\circ\text{C}$) (See [Note 1](#))

Symbol	Parameter	Test conditions	Min.	Typ.	Max.	Unit
V_{OD1}	Differential driver output (no load)				5	V
V_{OD2}	Differential driver output (with load)	$R_L = 27\Omega$ (RS-485), (See Figure 2.) $R_L = 50\Omega$ (RS-422), (See Figure 2.)	1.5		5 5	V V
ΔV_{OD}	Change in magnitude of driver differential output voltage for complementary output states	$R_L = 27\Omega$ or 50Ω (See Figure 2.)			0.2	V
V_{OC}	Driver common-mode output voltage	$R_L = 27\Omega$ or 50Ω (See Figure 2.)			3	V
ΔV_{OC}	Change in magnitude of driver common-mode output voltage for complementary output states	$R_L = 27\Omega$ or 50Ω (See Figure 2.)			0.2	V
V_{IH}	Input high voltage	\overline{RE} , DE, DI	2.0			V
V_{IL}	Input low voltage	\overline{RE} , DE, DI			0.8	V
I_{IN1}	Input current	\overline{RE} , DE, DI			± 2	μA
I_{IN2}	Input current (A, B)	$V_{CM} = 0\text{V}$ or 5.25V , $V_{DE} = 0\text{V}$ $V_{IN} = 12\text{V}$ $V_{IN} = -7\text{V}$			1 -0.8	mA mA
V_{TH}	Receiver differential threshold voltage	$V_{CM} = -7$ to 12V	-0.2		0.2	V
ΔV_{TH}	Receiver input hysteresis	$V_{CM} = 0\text{V}$		70		mV
V_{OH}	Receiver output high voltage	$I_O = -4\text{mA}$, $V_{ID} = 200\text{mV}$	3.5			V
V_{OL}	Receiver output low voltage	$I_O = 4\text{mA}$, $V_{ID} = -200\text{mV}$			0.4	V
I_{OZR}	3-State (high impedance) output current at receiver	$V_O = 0.4$ to 2.4V			± 1	μA
R_{IN}	Receiver input resistance	$V_{CM} = -7$ to 12V	12			KW
I_{CC}	No load supply current (Note 2)	$V_{RE} = 0\text{V}$ or V_{CC} $V_{DE} = V_{CC}$ $V_{DE} = 0\text{V}$		400 300	900 500	μA μA
I_{OSD1}	Driver short-circuit current, $V_O = \text{High}$	$V_O = -7$ to 12V (Note 3)	35		250	mA

Table 6. DC electrical characteristics (continued)

($V_{CC} = 5\text{ V} \pm 5\%$, $T_A = T_{MIN}$ to T_{MAX} , unless otherwise specified. Typical values are referred to $T_A = 25\text{ }^\circ\text{C}$) (See [Note 1](#))

Symbol	Parameter	Test conditions	Min.	Typ.	Max.	Unit
I_{OSD2}	Driver short-circuit current, $V_O = \text{Low}$	$V_O = -7$ to 12 V (Note 3)	35		250	mA
I_{OSR}	Receiver short-circuit current	$V_O = 0\text{ V}$ to V_{CC}	7		95	mA

- 1 All currents into device pins are positive; all cuts out of device pins are negative; all voltages are referenced to device ground unless specified.
- 2 Supply current specification is valid for loaded transmitters when $V_{DE} = 0\text{ V}$
- 3 Applies to peak current. See typical operating characteristics.

Table 7. Driver switching characteristics

($V_{CC} = 5\text{ V} \pm 5\%$, $T_A = T_{MIN}$ to T_{MAX} , unless otherwise specified. Typical values are referred to $T_A = 25\text{ }^\circ\text{C}$) (See [Note 1](#))

Symbol	Parameter	Test Conditions	Min.	Typ.	Max.	Unit
t_{PLH} t_{PHL}	Propagation delay input to output	$R_{DIFF} = 54\Omega$, $C_{L1} = C_{L2} = 100\text{ pF}$ (See Figure 4 and Figure 6)	10	30	60	ns
t_{SK}	Output skew to output	$R_{DIFF} = 54\Omega$, $C_{L1} = C_{L2} = 100\text{ pF}$ (See Figure 4 and Figure 6)		5	10	ns
t_{TLH} t_{THL}	Rise or fall time	$R_{DIFF} = 54\Omega$, $C_{L1} = C_{L2} = 100\text{ pF}$ (See Figure 4 and Figure 6)	3	15	40	ns
t_{PZH}	Output enable time	$C_L = 100\text{ pF}$, $S2 = \text{Closed}$ (See Figure 5 and Figure 7)		40	70	ns
t_{PZL}	Output enable time	$C_L = 100\text{ pF}$, $S1 = \text{Closed}$ (See Figure 5 and Figure 7)		40	70	ns
t_{PLZ}	Output disable time	$C_L = 15\text{ pF}$, $S1 = \text{Closed}$ (See Figure 5 and Figure 7)		40	70	ns
t_{PHZ}	Output disable time	$C_L = 15\text{ pF}$, $S2 = \text{Closed}$ (See Figure 5 and Figure 7)		40	70	ns

Note: 1 All currents into device pins are positive; all cuts out of device pins are negative; all voltages are referenced to device ground unless specified.

Table 8. Receiver switching characteristics

($V_{CC} = 5V \pm 5\%$, $T_A = T_{MIN}$ to T_{MAX} , unless otherwise specified. Typical values are referred to $T_A = 25^\circ C$) (See Note 1)

Symbol	Parameter	Test Conditions	Min.	Typ.	Max.	Unit
t_{PLH} t_{PHL}	Propagation delay input to output	$R_{DIFF} = 54\Omega$, $C_{L1} = C_{L2} = 100pF$ (See Figure 4 and Figure 8)	20	130	210	ns
t_{SKD}	Differential receiver skew	$R_{DIFF} = 54\Omega$, $C_{L1} = C_{L2} = 100pF$ (See Figure 4 and Figure 8)		13		ns
t_{PZH}	Output enable time	$C_{RL} = 15pF$, S1 = Closed (See Figure 3 and Figure 9)		20	50	ns
t_{PZL}	Output enable time	$C_{RL} = 15pF$, S2 = Closed (See Figure 3 and Figure 9)		20	50	ns
t_{PLZ}	Output disable time	$C_{RL} = 15pF$, S1 = Closed (See Figure 3 and Figure 9)		20	50	ns
t_{PHZ}	Output disable time	$C_{RL} = 15pF$, S2 = Closed (See Figure 3 and Figure 9)		20	50	ns
f_{MAX}	Maximum data rate		2.5			Mbps

Note: All currents into device pins are positive; all cuts out of device pins are negative; all voltages are referenced to device ground unless specified.

5 Test circuits and typical characteristics

Figure 2. Driver DC test load

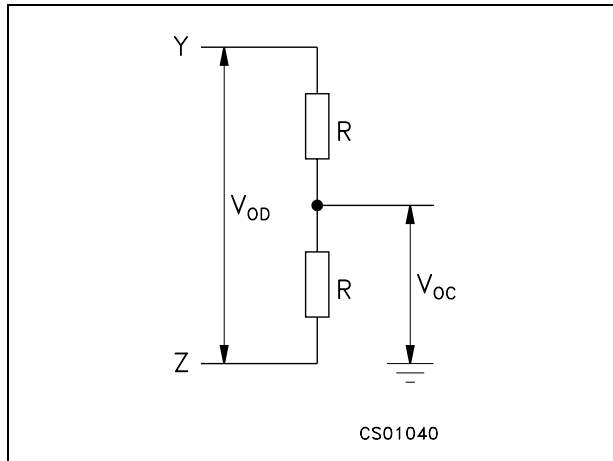

Figure 3. Receiver timing test load

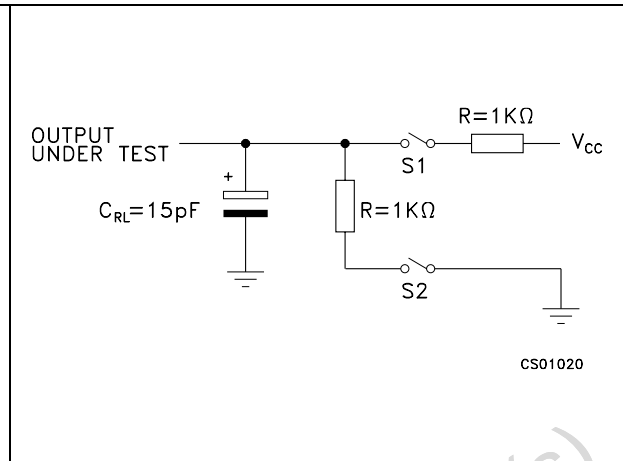

Figure 4. Drive/receiver timing test circuit

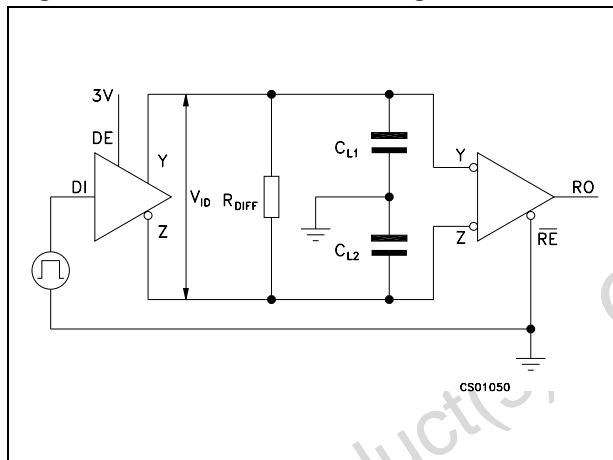

Figure 5. Driver timing test load

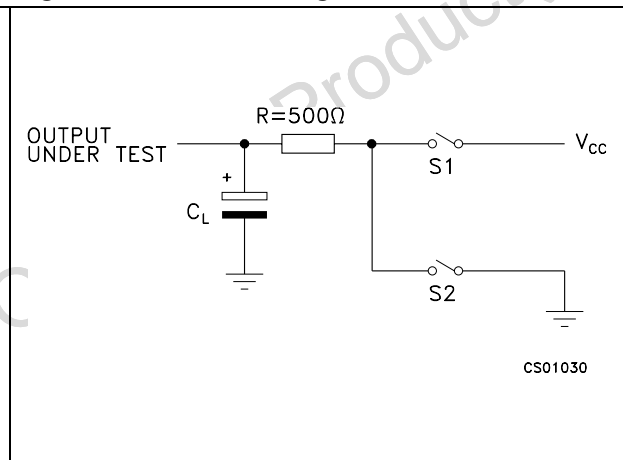

Figure 6. Driver propagation delay

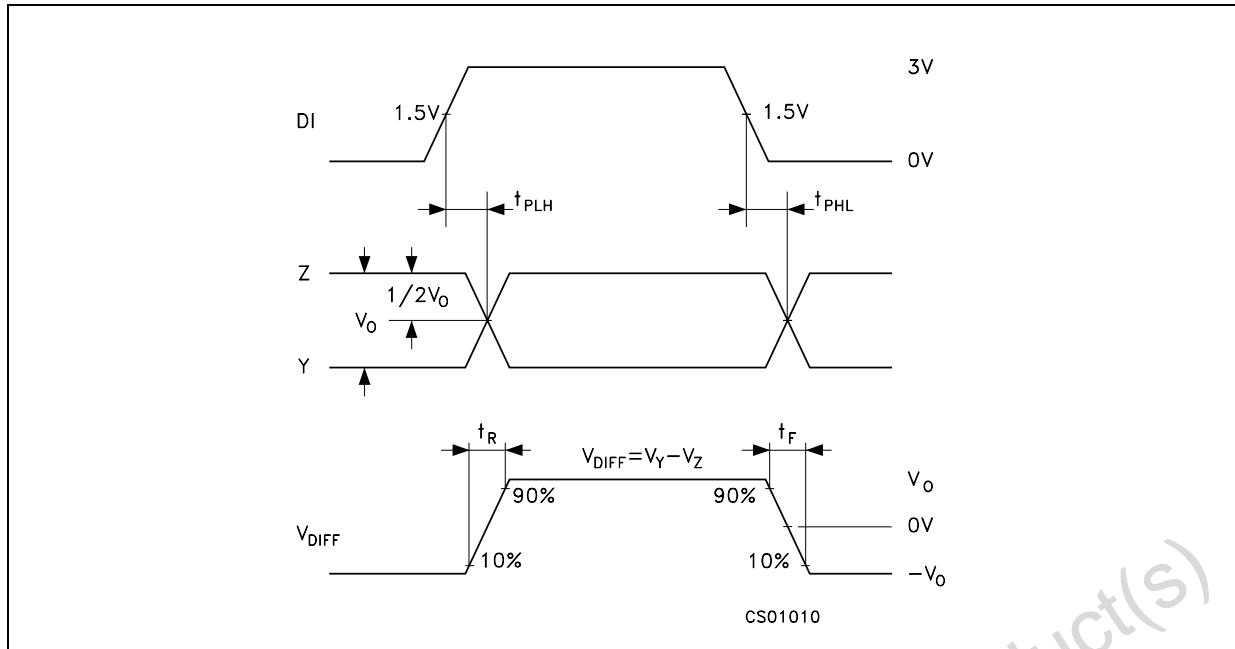

Figure 7. Driver enable and disable time

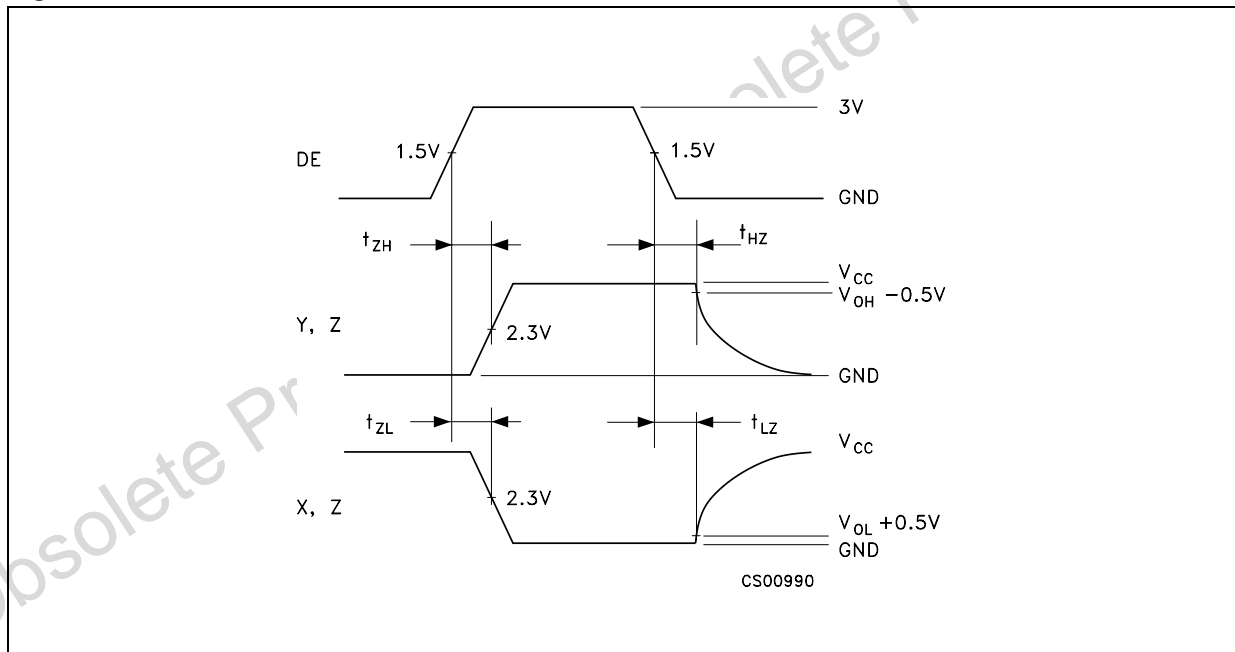

Figure 8. Receiver propagation delay

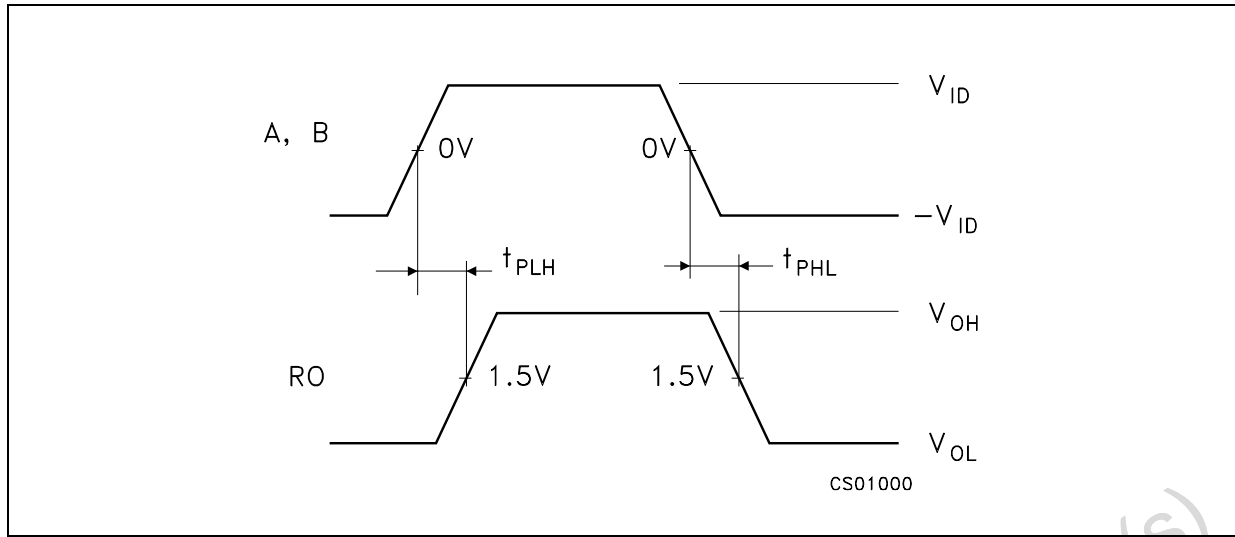

Figure 9. Receiver enable and disable time

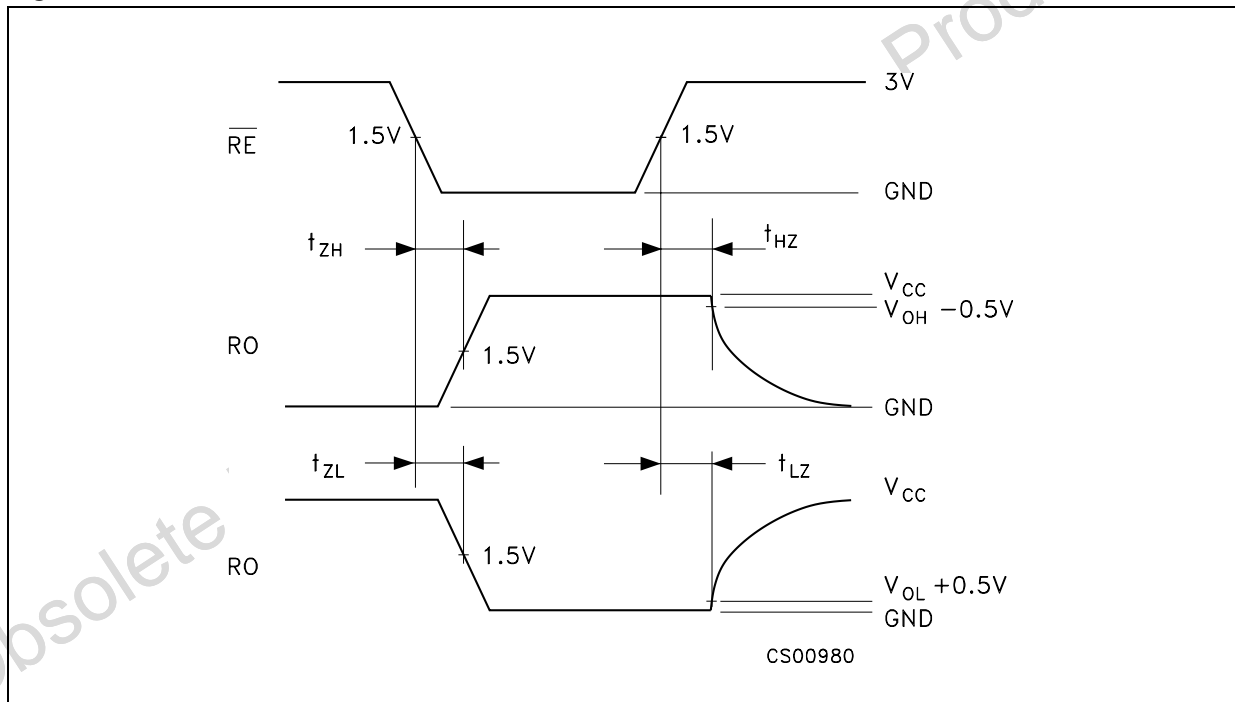

Figure 10. Receiver output current vs output low voltage

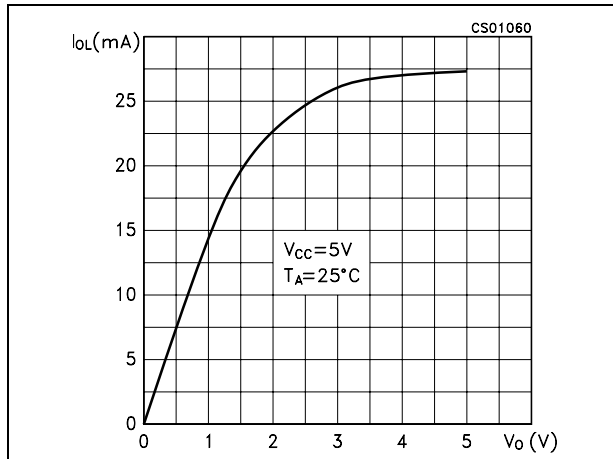

Figure 11. Receiver output current vs output high voltage

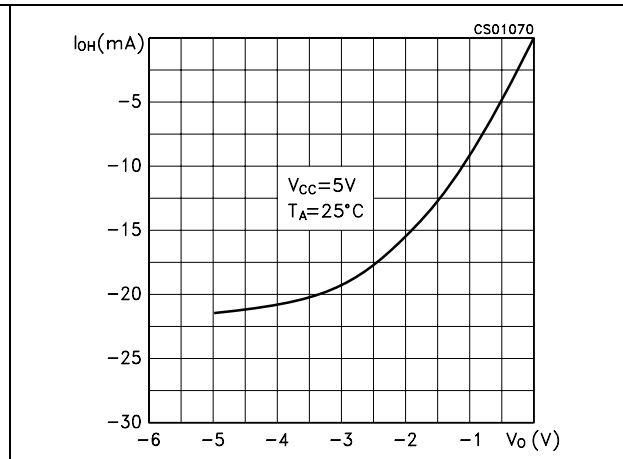

Figure 12. Driver output current vs output low voltage

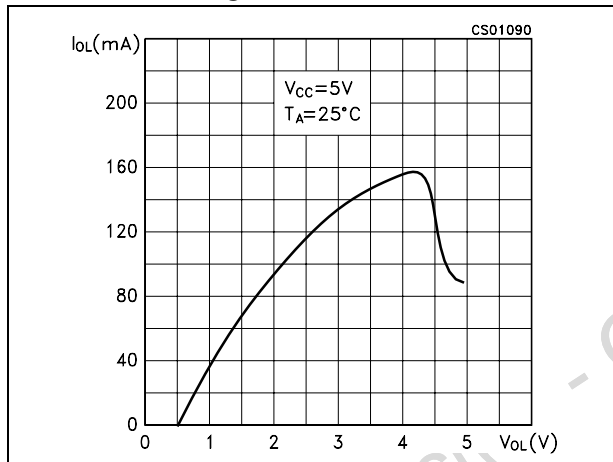

Figure 13. Driver output current vs output high voltage

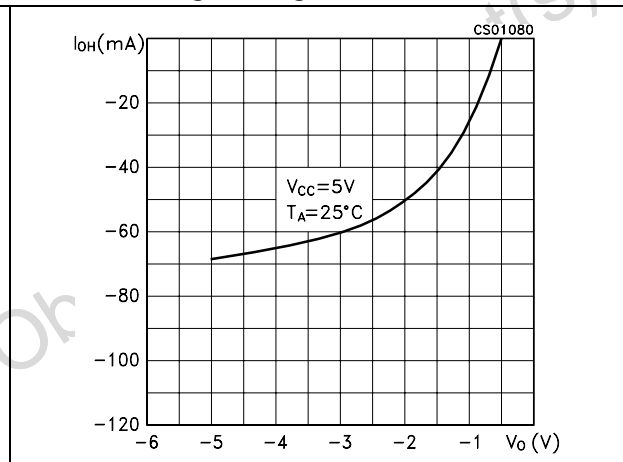

Figure 14. Supply current vs temperature

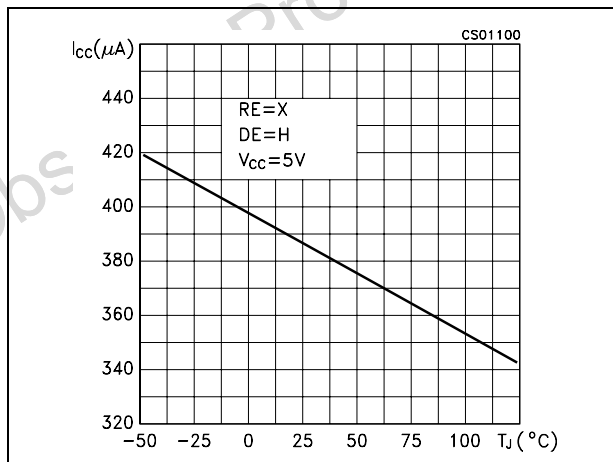

Figure 15. Receiver high level output voltage vs temperature

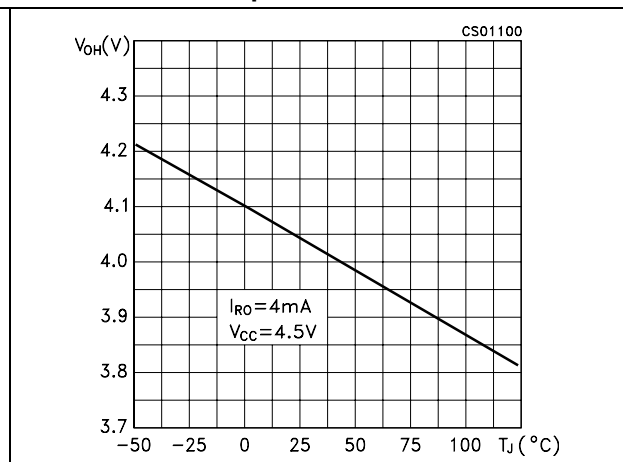

Figure 16. Receiver low level output voltage vs temperature

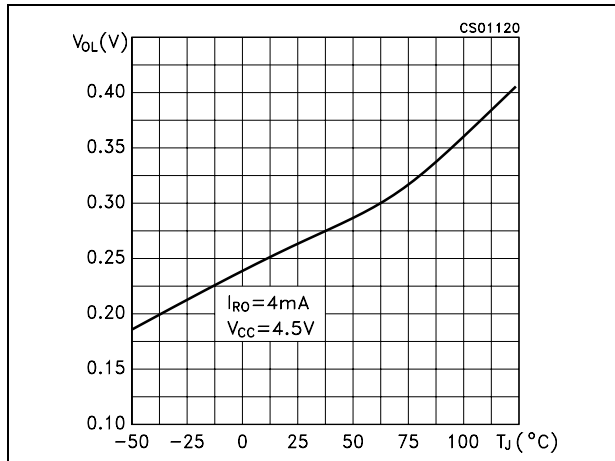
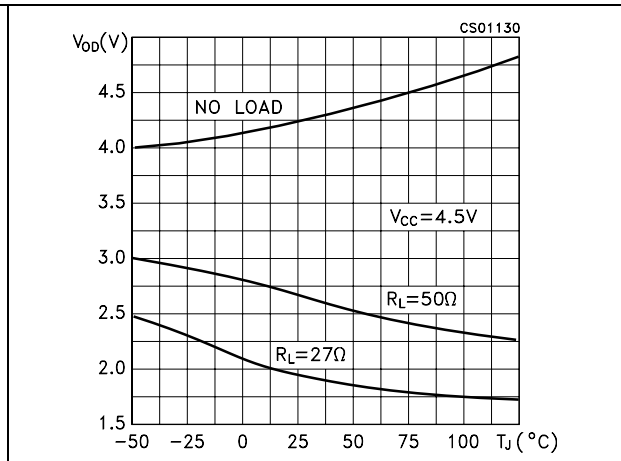

Figure 17. Differential driver output voltage vs temperature



Obsolete Product(s) - Obsolete Product(s)

6 Package mechanical data

In order to meet environmental requirements, ST offers these devices in ECOPACK® packages. These packages have a lead-free second level interconnect. The category of second level interconnect is marked on the package and on the inner box label, in compliance with JEDEC Standard JESD97. The maximum ratings related to soldering conditions are also marked on the inner box label. ECOPACK is an ST trademark. ECOPACK specifications are available at: www.st.com

Obsolete Product(s) - Obsolete Product(s)

Plastic DIP-8 MECHANICAL DATA

DIM.	mm.			inch		
	MIN.	TYP	MAX.	MIN.	TYP.	MAX.
A		3.3			0.130	
a1	0.7			0.028		
B	1.39		1.65	0.055		0.065
B1	0.91		1.04	0.036		0.041
b		0.5			0.020	
b1	0.38		0.5	0.015		0.020
D			9.8			0.386
E		8.8			0.346	
e		2.54			0.100	
e3		7.62			0.300	
e4		7.62			0.300	
F			7.1			0.280
I			4.8			0.189
L		3.3			0.130	
Z	0.44		1.6	0.017		0.063

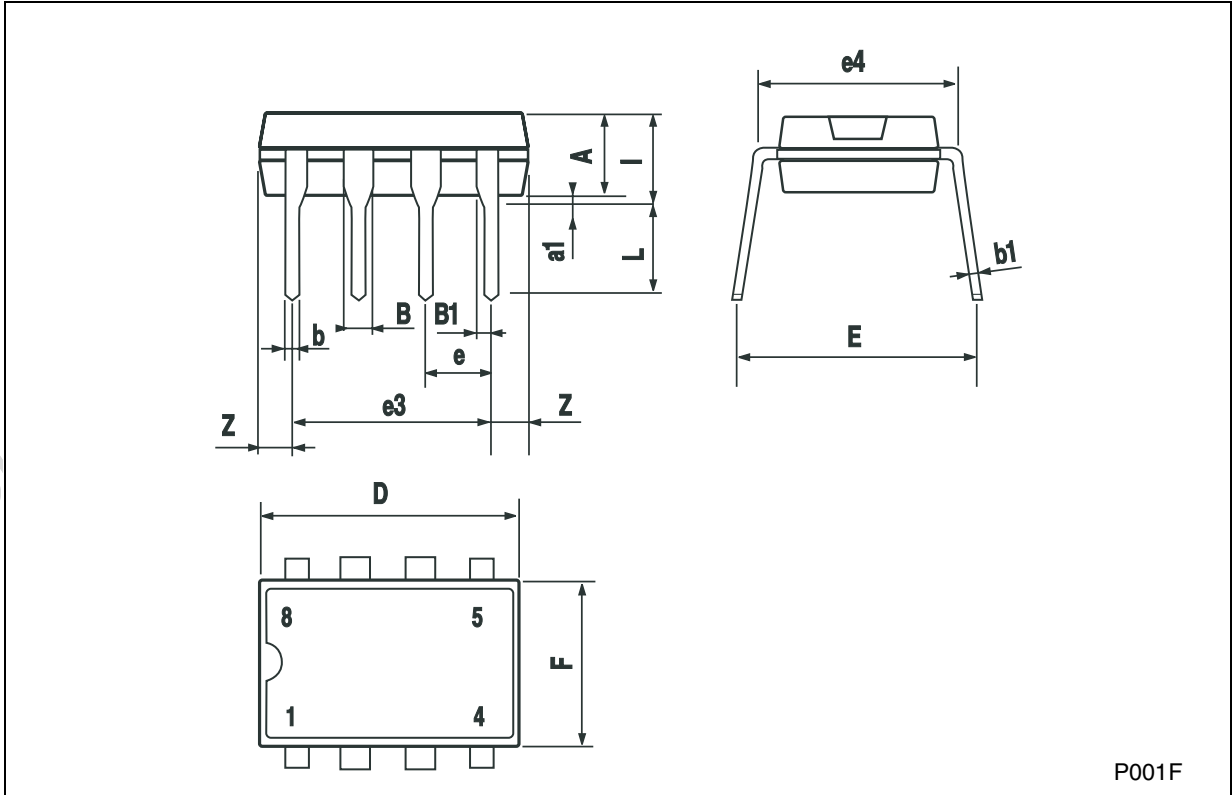

7 Revision history

Table 9. Document revision history

Date	Revision	Changes
04-May-2006	3	Order codes updated.
07-Nov-2007	4	Added Table 1 .

Obsolete Product(s) - Obsolete Product(s)

Please Read Carefully:

Information in this document is provided solely in connection with ST products. STMicroelectronics NV and its subsidiaries ("ST") reserve the right to make changes, corrections, modifications or improvements, to this document, and the products and services described herein at any time, without notice.

All ST products are sold pursuant to ST's terms and conditions of sale.

Purchasers are solely responsible for the choice, selection and use of the ST products and services described herein, and ST assumes no liability whatsoever relating to the choice, selection or use of the ST products and services described herein.

No license, express or implied, by estoppel or otherwise, to any intellectual property rights is granted under this document. If any part of this document refers to any third party products or services it shall not be deemed a license grant by ST for the use of such third party products or services, or any intellectual property contained therein or considered as a warranty covering the use in any manner whatsoever of such third party products or services or any intellectual property contained therein.

UNLESS OTHERWISE SET FORTH IN ST'S TERMS AND CONDITIONS OF SALE ST DISCLAIMS ANY EXPRESS OR IMPLIED WARRANTY WITH RESPECT TO THE USE AND/OR SALE OF ST PRODUCTS INCLUDING WITHOUT LIMITATION IMPLIED WARRANTIES OF MERCHANTABILITY, FITNESS FOR A PARTICULAR PURPOSE (AND THEIR EQUIVALENTS UNDER THE LAWS OF ANY JURISDICTION), OR INFRINGEMENT OF ANY PATENT, COPYRIGHT OR OTHER INTELLECTUAL PROPERTY RIGHT.

UNLESS EXPRESSLY APPROVED IN WRITING BY AN AUTHORIZED ST REPRESENTATIVE, ST PRODUCTS ARE NOT RECOMMENDED, AUTHORIZED OR WARRANTED FOR USE IN MILITARY, AIR CRAFT, SPACE, LIFE SAVING, OR LIFE SUSTAINING APPLICATIONS, NOR IN PRODUCTS OR SYSTEMS WHERE FAILURE OR MALFUNCTION MAY RESULT IN PERSONAL INJURY, DEATH, OR SEVERE PROPERTY OR ENVIRONMENTAL DAMAGE. ST PRODUCTS WHICH ARE NOT SPECIFIED AS "AUTOMOTIVE GRADE" MAY ONLY BE USED IN AUTOMOTIVE APPLICATIONS AT USER'S OWN RISK.

Resale of ST products with provisions different from the statements and/or technical features set forth in this document shall immediately void any warranty granted by ST for the ST product or service described herein and shall not create or extend in any manner whatsoever, any liability of ST.

ST and the ST logo are trademarks or registered trademarks of ST in various countries.

Information in this document supersedes and replaces all information previously supplied.

The ST logo is a registered trademark of STMicroelectronics. All other names are the property of their respective owners.

© 2007 STMicroelectronics - All rights reserved

STMicroelectronics group of companies

Australia - Belgium - Brazil - Canada - China - Czech Republic - Finland - France - Germany - Hong Kong - India - Israel - Italy - Japan - Malaysia - Malta - Morocco - Singapore - Spain - Sweden - Switzerland - United Kingdom - United States of America

www.st.com

Looking for pricing, stock, or lifecycle information?

Click below to explore more details on WIN SOURCE:

 [View ST75C176CDR](#) on WIN SOURCE

 [STMicroelectronics](#) Information

Optimize Your Supply Chain with WIN SOURCE Solutions

-  Global Sourcing Solution
-  Obsolete Management
-  Cost Control Management
-  Shortage Management
-  Alternative Solution
-  Excess Inventory Management