



**THE DATASHEET OF
LM2758TLEV**



LM2758 Switched Capacitor Flash LED Driver in DSBGA Package

1 Features

- Up to 700-mA Output Current
- 90% Peak Efficiency
- Indicator, Torch, and Flash Modes
- Time-Out Circuitry Limits Flash Duration to 814 Milliseconds (Typical)
- Adaptive 1× and 1.5× Gains for Maximum Efficiency
- True Shutdown
- Internal Soft-Start Eliminates Inrush Current
- Ultra-Small Solution Size
 - No Inductor, Only 4 Capacitors and a Resistor Required
 - 2.022 mm × 1.527 mm × 0.6 mm Thin DSBGA package

2 Applications

- Camera Flash in Mobile Phones
- Flash for Digital Cameras

3 Description

The LM2758 device is an integrated low-noise, high-current switched capacitor DC-DC converter with a regulated current sink. The device is capable of driving loads up to 700 mA from a single-cell Li-Ion battery. Maximum efficiency is achieved over the input voltage range by actively selecting the proper gain based on the LED forward voltage and current requirements.

One external low-power resistor sets the desired current for indicator, torch, and flash modes. To protect the devices and the flash LED, internal time-out circuitry turns off the LM2758 in case of a faulty prolonged flash mode. Internal soft-start circuitry limits the amount of inrush current during start-up.

Device Information⁽¹⁾

PART NUMBER	PACKAGE	BODY SIZE (MAX)
LM2758	DSBGA (12)	2.022 mm × 1.527 mm

(1) For all available packages, see the orderable addendum at the end of the data sheet.

Typical Application Circuit

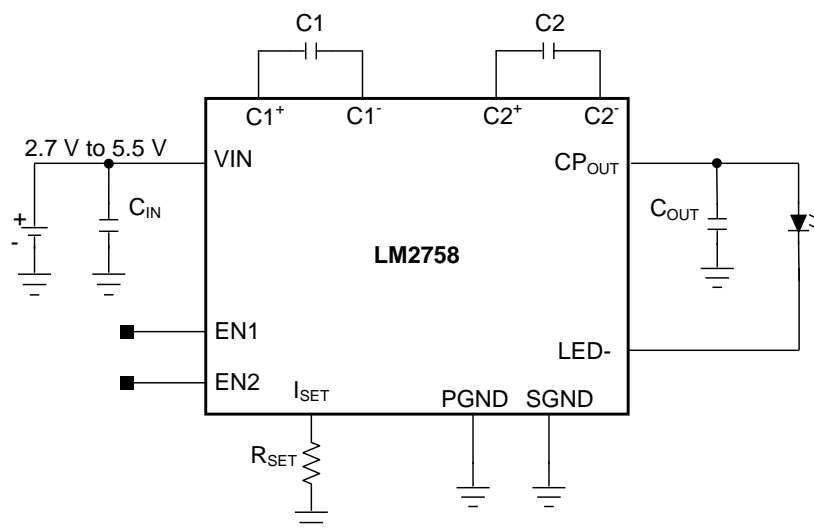

Copyright © 2016, Texas Instruments Incorporated



Table of Contents

1 Features	1	8 Application and Implementation	11
2 Applications	1	8.1 Application Information.....	11
3 Description	1	8.2 Typical Application	11
4 Revision History	2	9 Power Supply Recommendations	14
5 Pin Configuration and Functions	3	9.1 Power Dissipation	14
6 Specifications	4	10 Layout	15
6.1 Absolute Maximum Ratings	4	10.1 Layout Guidelines	15
6.2 ESD Ratings.....	4	10.2 Layout Example	15
6.3 Recommended Operating Conditions.....	4	10.3 DSBGA Package Assembly and Use	16
6.4 Thermal Information	4	11 Device and Documentation Support	17
6.5 Electrical Characteristics.....	5	11.1 Device Support.....	17
6.6 Typical Characteristics.....	6	11.2 Documentation Support	17
7 Detailed Description	7	11.3 Community Resources.....	17
7.1 Overview	7	11.4 Trademarks	17
7.2 Functional Block Diagram	7	11.5 Electrostatic Discharge Caution.....	17
7.3 Feature Description.....	7	11.6 Glossary	17
7.4 Device Functional Modes.....	10	12 Mechanical, Packaging, and Orderable Information	17

4 Revision History

NOTE: Page numbers for previous revisions may differ from page numbers in the current version.

Changes from Revision D (May 2013) to Revision E	Page
• Added <i>Device Information</i> and <i>Pin Configuration and Functions</i> sections, <i>ESD Ratings</i> table, <i>Feature Description</i> , <i>Device Functional Modes</i> , <i>Application and Implementation</i> , <i>Power Supply Recommendations</i> , <i>Layout</i> , <i>Device and Documentation Support</i> , and <i>Mechanical, Packaging, and Orderable Information</i> sections	1
• Added <i>Thermal Information</i> table with revised $R_{\theta JA}$ value (from 56°C/W to 93.6°C/W) and additional thermal values.	4

Changes from Revision C (May 2013) to Revision D	Page
• Changed layout of National Semiconductor Data Sheet to TI format	16

5 Pin Configuration and Functions

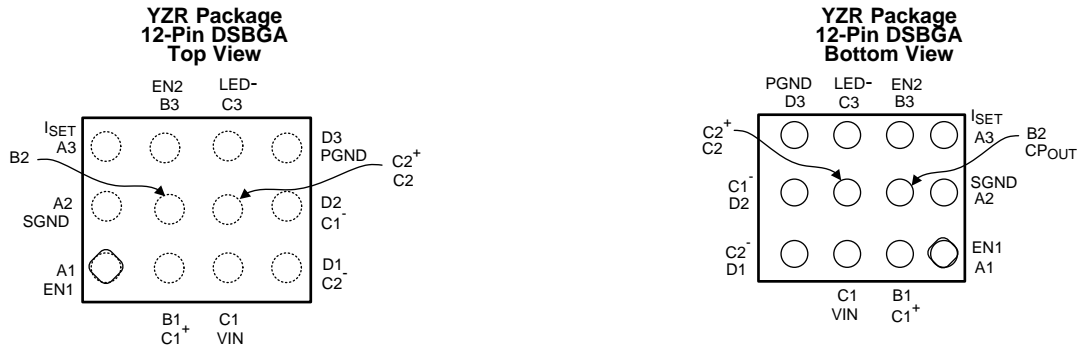

Pin Functions

PIN		TYPE	DESCRIPTION
NO.	NAME		
A1	EN1	Input	The EN2 pins is used to select the modes (torch, indicator, flash), as well as to put the part into shutdown mode.
A2	SGND	Ground	Analog and control ground for charge pump. Connect this pin directly to a low impedance ground plane.
A3	I _{SET}	Power	LED current programming resistor pin. A resistor connected between this pin, and GND is used to set torch, flash and indicator currents.
B1	C1+	Power	Flying capacitor pin — connect a 1- μ F ceramic capacitor from C1+ to C1-
B2	CP _{OUT}	Output	Charge pump regulated output. A 2.2- μ F ceramic capacitor is required from CP _{OUT} to GND. Connect flash LED anode to this pin.
B3	EN2	Input	The EN1 pin is used to select the modes (torch, indicator, flash), as well as to put the part into Shutdown mode.
C1	VIN	Input	Supply voltage connection
C2	C2+	Power	Flying capacitor pins — connect a 1- μ F ceramic capacitor from C2+ to C2-.
C3	LED-	Output	Regulated current source output. Connect flash LED cathode to this pin.
D1	C2-	Power	Flying capacitor pin — connect a 1- μ F ceramic capacitor from C2+ to C2-.
D2	C1-	Power	Flying capacitor pin — connect a 1- μ F ceramic capacitor from C1+ to C1-
D3	PGND	Ground	Power ground for the charge pump and the current source. Connected the pin directly to a low-impedance ground plane.

6 Specifications

6.1 Absolute Maximum Ratings

 over operating free-air temperature range (unless otherwise noted)⁽¹⁾⁽²⁾⁽³⁾

	MIN	MAX	UNIT
V _{IN} , CP _{OUT} pins: voltage to GND	-0.3	6	V
EN1, EN2 pins: Voltage to GND	-0.3	(V _{IN} + 0.3) w/ 6 V maximum	V
Continuous power dissipation			
Junction temperature, T _{J-MAX}		150	°C
Maximum lead temperature (soldering)		See ⁽⁴⁾	
Storage temperature, T _{stg}	-65°C	150	°C

- (1) Stresses beyond those listed under *Absolute Maximum Ratings* may cause permanent damage to the device. These are stress ratings only, which do not imply functional operation of the device at these or any other conditions beyond those indicated under *Recommended Operating Conditions*. Exposure to absolute-maximum-rated conditions for extended periods may affect device reliability.
- (2) If Military/Aerospace specified devices are required, contact the Texas Instruments Sales Office/ Distributors for availability and specifications.
- (3) All voltages are with respect to the potential to the GND pin.
- (4) For detailed soldering specifications and information, see *AN-1112 DSBGA Wafer Level Chip Scale Package (SNVA009)*.

6.2 ESD Ratings

		VALUE	UNIT
V _(ESD) Electrostatic discharge	Human-body model (HBM), per ANSI/ESDA/JEDEC JS-001 ⁽¹⁾	±2000	V
	Charged-device model (CDM), per JEDEC specification JESD22-C101 ⁽²⁾	±200	

- (1) JEDEC document JEP155 states that 500-V HBM allows safe manufacturing with a standard ESD control process.
- (2) JEDEC document JEP157 states that 250-V CDM allows safe manufacturing with a standard ESD control process.

6.3 Recommended Operating Conditions

 over operating free-air temperature range (unless otherwise noted)⁽¹⁾

	MIN	MAX	UNIT
Input voltage	2.7	5.5	V
Junction temperature, T _J	-40	125	°C
Ambient temperature, T _A ⁽²⁾	-40	85	°C

- (1) All voltages are with respect to the potential at the GND pin.
- (2) In applications where high power dissipation and/or poor package thermal resistance is present, the maximum ambient temperature may have to be derated. Maximum ambient temperature (T_{A-MAX}) is dependent on the maximum operation junction temperature (T_{J-MAX-OP} = 125°C), the maximum power dissipation of the device in the application (P_{D-MAX}), and the junction-to ambient thermal resistance of the part/package in the application (R_{θJA}), as given by the following equation: T_{A-MAX} = T_{J-MAX-OP} - (R_{θJA} × P_{D-MAX}).

6.4 Thermal Information

THERMAL METRIC ⁽¹⁾		LM2758	UNIT
		YZR (DSBGA)	
		12 PINS	
R _{θJA}	Junction-to-ambient thermal resistance	93.6	°C/W
R _{θJC(top)}	Junction-to-case (top) thermal resistance	0.7	°C/W
R _{θJB}	Junction-to-board thermal resistance	16.1	°C/W
ψ _{JT}	Junction-to-top characterization parameter	2.9	°C/W
ψ _{JB}	Junction-to-board characterization parameter	16.0	°C/W

- (1) For more information about traditional and new thermal metrics, see the *Semiconductor and IC Package Thermal Metrics* application report, SPRA953.

6.5 Electrical Characteristics

Unless otherwise specified, aspecifications apply to the [Figure 8](#) with $V_{IN} = 3.6\text{ V}$, $V_{EN1} = V_{IN}$, $V_{EN2} = 0\text{ V}$, $C1 = C2 = 1\text{ }\mu\text{F}$, $C_{IN} = C_{OUT} = 2.2\text{ }\mu\text{F}$, $R_{SET} = 20\text{ k}\Omega$, $T_J = 25^\circ\text{C}$.⁽¹⁾⁽²⁾⁽³⁾

PARAMETER		TEST CONDITIONS	MIN	TYP	MAX	UNIT
I_{LED}	LED current accuracy	$I_{LED} = 500\text{ mA}$, flash mode		500		
		$I_{LED} = 500\text{ mA}$, flash mode $-40^\circ\text{C} \leq T_J \leq 125^\circ\text{C}$	450		550	mA
V_{SET}	I_{SET} pin voltage			1.3		V
I_D/I_{SET}	LED current to set current ratio	Flash mode		7650		
		Torch mode		1639		
$I_{LED-IND}$	Indicator current level	Indicator mode 32-kHZ PWM mode		$1/32 \times I_{LED-TORCH}$		mA
V_{GDX}	1x to 1.5x gain transition voltage threshold on V_{LED-}	$I_{OUT} = 500\text{ mA}$		300		mV
V_{OUT}	Output voltage	1x mode, $I_{OUT} = 0\text{ mA}$		V_{IN}		
		1.5x mode, $I_{OUT} = 0\text{ mA}$ ⁽⁴⁾		4.8		V
		1.5x mode, $I_{OUT} = 0\text{ mA}$ $-40^\circ\text{C} \leq T_J \leq 125^\circ\text{C}$ ⁽⁴⁾			5.3	
R_{OUT}	1x mode output impedance	$I_{OUT} = 200\text{ mA}$, $V_{IN} = 3.3\text{ V}$ $-40^\circ\text{C} \leq T_J \leq 125^\circ\text{C}$		0.33		
		$I_{OUT} = 200\text{ mA}$, $V_{IN} = 3.3\text{ V}$ ⁽⁵⁾			0.53	Ω
	1.5x mode output impedance	$I_{OUT} = 500\text{ mA}$, $V_{IN} = 3.3\text{ V}$ ⁽⁵⁾		1.5	2.0	
F_{SW}	Switching frequency			1.25		
		$-40^\circ\text{C} \leq T_J \leq 125^\circ\text{C}$	0.8		1.5	MHz
I_Q	Quiescent current	$I_{OUT} = 0\text{ mA}$ 1x mode, $-40^\circ\text{C} \leq T_J \leq 125^\circ\text{C}$		0.7		
		$I_{OUT} = 0\text{ mA}$ 1x mode			0.8	mA
		$I_{OUT} = 0\text{ mA}$ 1.5x mode		4		
		$I_{OUT} = 0\text{ mA}$ 1.5x mode, $-40^\circ\text{C} \leq T_J \leq 125^\circ\text{C}$			5	
I_{SD}	Shutdown current	Device disabled ⁽⁶⁾		0.01		μA
		Device disabled, $-40^\circ\text{C} \leq T_J \leq 125^\circ\text{C}$ ⁽⁶⁾			1	
T_{OUT}	Timeout duration	$-40^\circ\text{C} \leq T_J \leq 125^\circ\text{C}$, see ⁽⁷⁾		814		msec
		See ⁽⁷⁾	640		1000	
V_{IH}	Input logic high	Pins: EN1, EN2, $-40^\circ\text{C} \leq T_J \leq 125^\circ\text{C}$	1.2			V
V_{IL}	Input logic low	Pins: EN1, EN2, $-40^\circ\text{C} \leq T_J \leq 125^\circ\text{C}$			0.4	V

(1) All voltages are with respect to the potential at the GND pin.

(2) Minimum (MIN) and maximum (MAX) limits are specified by design, test, or statistical analysis. Typical (TYP) numbers are not ensured, but do represent the most likely norm. Unless otherwise specified, conditions for TTYP specifications are: $V_{IN} = 3.6\text{ V}$ and $T_A = 25^\circ\text{C}$.

(3) C_{IN} , C_{OUT} , C1, C2: Low-ESR surface-mount ceramic capacitors (MLCCs) used in setting electrical characteristics.

(4) Output voltage is internally limited not to exceed maximum specified value.

(5) These table entries are specified by design. These parameters are not ensured by production testing. The temperature limits for test are $(-40^\circ\text{C} \leq T_A \leq +85^\circ\text{C})$.

(6) The temperature limits for I_{SD} (shutdown current) test are $-40^\circ\text{C} \leq T_A \leq +85^\circ\text{C}$, as in shutdown mode ambient temperature is equal to junction temperature.

(7) The timeout specifications are calculated values based on the switching frequency spread.

6.6 Typical Characteristics

Unless otherwise specified: $T_A = 25^\circ\text{C}$, $V_{IN} = 3.6\text{ V}$, $C_{IN} = C_{OUT} = 2.2\ \mu\text{F}$, $C_1 = C_2 = 1\ \mu\text{F}$. Capacitors are low-ESR multi-layer ceramic capacitors (MLCCs). Luxeon PWF1 Flash LED.

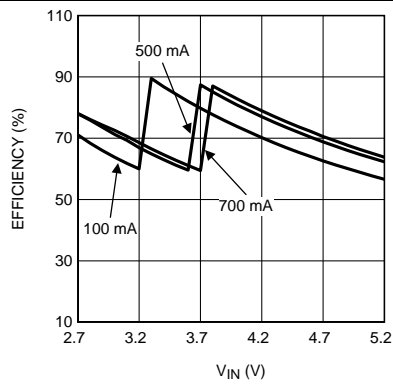

Figure 1. Efficiency vs V_{IN}

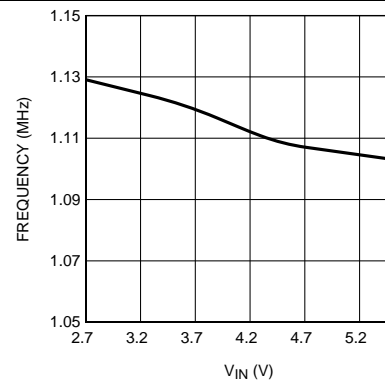

Figure 2. Oscillator Frequency vs V_{IN}

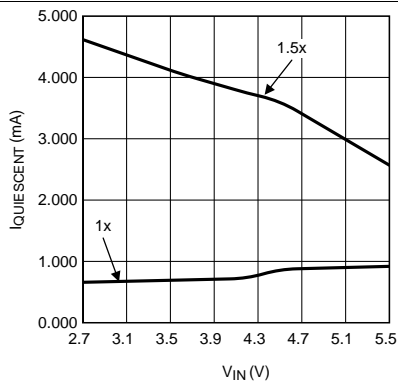

Figure 3. Quiescent Current vs V_{IN}

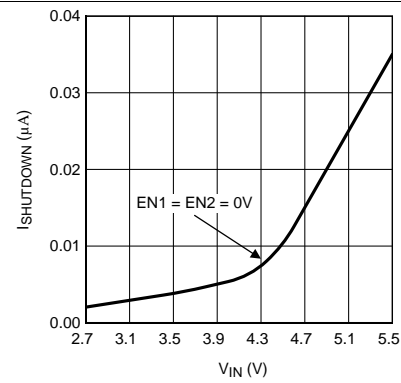

Figure 4. Shutdown Current vs V_{IN}

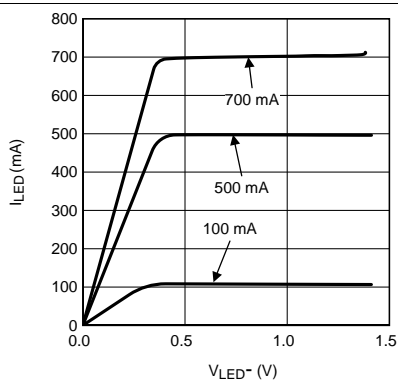

Figure 5. I_{LED} vs V_{LED-}

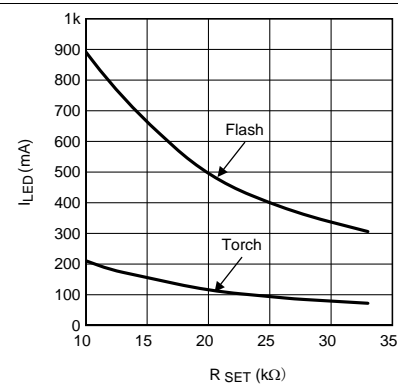

Figure 6. LED Current vs R_{SET}

7 Detailed Description

7.1 Overview

The LM2758 is an adaptive 1x and 1.5x CMOS charge pump, optimized for driving flash LEDs in camera phones and other portable applications. It provides a constant current of 500 mA (typical) for flash mode and 107 mA (typical) for torch mode with $R_{SET} = 20\text{ k}\Omega$. These current can change (see [Setting LED Currents](#)).

There are four modes of operation for LM2758: the flash mode, torch mode, indicator mode, and shutdown mode (see [Table 1](#)). Torch and flash modes sink a constant DC current while indicator mode operates in pulsating DC at 1/32 positive duty cycle with same current magnitude as torch mode. The LED is driven from CP_{OUT} and connected to the current sink. LED drive current mode is programmed by connecting a resistor, R_{SET} , to the current set pin, I_{SET} . The LM2758 device also controls CP_{OUT} with variable gain (1x or 1.5x) and adjustable impedance (R_{OUT}) to provide an output voltage that would account for LED forward voltage drop and headroom for the current sink to drive desired current through LED.

7.2 Functional Block Diagram

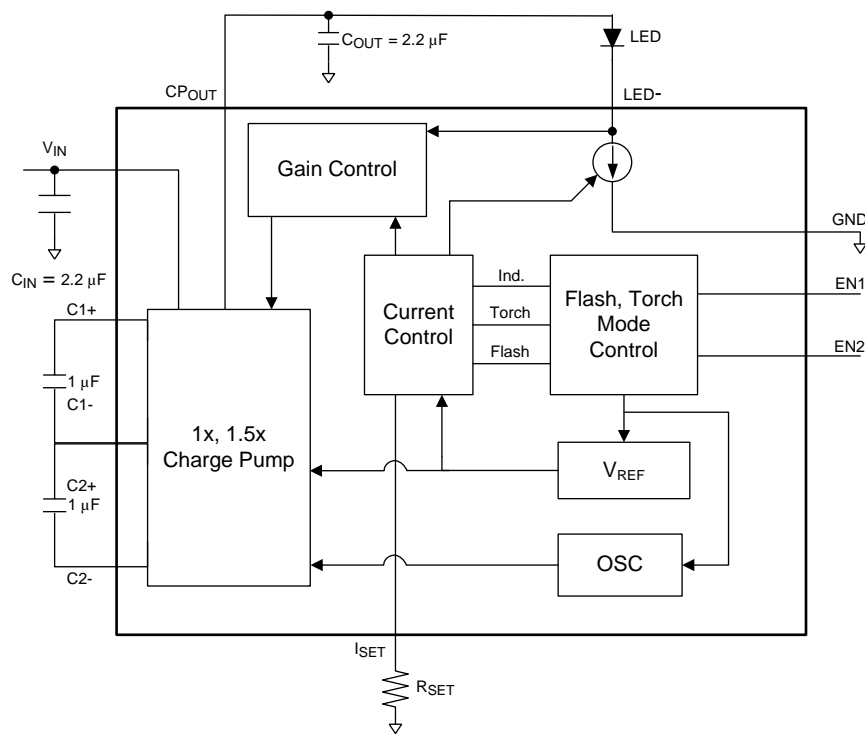

7.3 Feature Description

7.3.1 Charge Pump and Gain Transitions

The input to the 1x/1.5x charge pump is connected to the V_{IN} pin, and the loosely regulated output of the charge pump is connected to the CP_{OUT} pin. In 1x mode, as long as the input voltage is less than 4.7 V, the output voltage is approximately equal to the input voltage. When input voltage is over 4.7 V the output voltage is regulated to 4.7 V. In 1.5x mode, the output voltage is always less than or equal to 4.7 V over entire input voltage range.

The gain of the charge pump is selected depending on the headroom voltage across the current sink of LM2758. When headroom voltage V_{LED-} (at the LED pin) drops below 300 mV (typical) the charge-pump gain transition happens from 1x to 1.5x to maintain current regulation across the LED. Once the charge pump transition to a higher gain, it remains at that gain for as long as the device remains enabled. Shutting down and then re-enabling the device resets the gain mode to the minimum gain required to maintain the load.

Feature Description (continued)

7.3.2 Soft Start

The LM2758 contains internal soft-start circuitry to limit inrush currents when the part is enabled. Soft start is implemented internally with a controlled turnon of the internal voltage reference.

7.3.3 Current Limit Protection

The LM2758 charge pump contains current limit protection circuitry that protects the device during V_{OUT} fault conditions where excessive current is drawn. Output current is limited to 1.2 A typically.

7.3.4 Flash Time-out Feature

Flash time-out protection circuitry disables the current sinks when the signal on EN1 and EN2 is held high for more than 814 msec (typical). This prevents the device from self-heating due to the high power dissipation during flash conditions. During the time-out condition, voltage is still present on CP_{OUT} but the current sinks are shut off, resulting in no current through the flash LED. When the device goes into a time-out condition, placing a logic low signal on EN1 and EN2 resets the timeout; a subsequent logic high signal on EN1 or EN2 returns the device to normal operation.

7.3.5 Setting LED Currents

The current through the LED can be set by connecting an appropriately sized resistor R_{SET} between the I_{SET} pin of the LM2758 and GND.

The LED current in torch mode is approximately 1639 times greater than the current of I_{SET} , while the LED current in flash mode is approximately 7650 times of the same I_{SET} current. The feedback loop of an internal amplifier sets the voltage of the I_{SET} pin to 1.3 V (typical). The statements above are simplified in [Equation 1](#):

$$I_{LED} = GAIN_{FLASH/TORCH} \times (1.3 / R_{SET}) \quad (1)$$

The maximum recommended current through LED is 500 mA in torch mode / 700 mA in flash mode.

NOTE

If the I_{SET} for torch mode setting at 500 mA, the flash mode would be over 700 mA (maximum). See [Figure 6](#). Using the device in conditions where the junction temperature might rise above the rated maximum requires that the operating ranges and/or conditions be de-rated. The printed circuit board also must be carefully laid out to account for high thermal dissipation in the part.

Feature Description (continued)

7.3.6 Analog Brightness Control

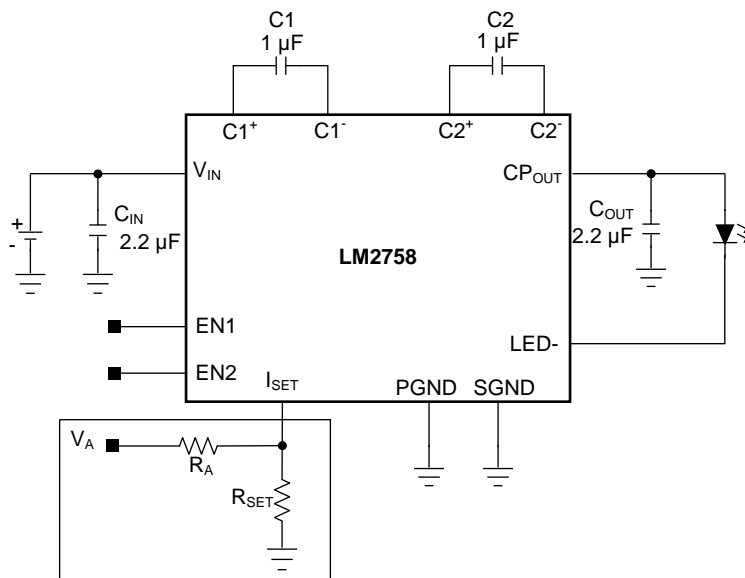

Copyright © 2016, Texas Instruments Incorporated

Figure 7. Analog Brightness Control

The current through the LED can be varied dynamically by changing the I_{SET} current. Figure 7 shows the circuit. The current through the LED can be calculated with Equation 2:

$$I_{LED} = Gain_{TORCH/FLASH} \left[\frac{1.3V}{R_{SET}} - \frac{V_A - 1.3V}{R_A} \right] \quad (2)$$

7.3.7 Thermal Protection

Internal thermal protection circuitry disables the LM2758 when the junction temperature exceeds 150°C (typical). This feature protects the device from being damaged by high die temperatures that might otherwise result from excessive power dissipation. The device recovers and operates normally when the junction temperature falls below 140°C (typical). It is important that the board layout provide good thermal conduction to keep the junction temperature within the specified operating ratings.

7.4 Device Functional Modes

7.4.1 Modes

There are four modes of operation for LM2758: the flash mode, torch mode, indicator mode and shutdown mode (see [Table 1](#)). Torch and flash modes sink a constant DC current while indicator mode operates in pulsating DC at 1/32 positive duty cycle with same current magnitude as torch mode.

7.4.2 Logic Control Pins

The LM2758 has two logic pins, EN1 and EN2. There is a 500-k Ω (typical) pulldown resistor connected from EN1 to GND and from EN2 to GND. The operating modes of the part function according to [Table 1](#):

Table 1. EN1 and EN2 Truth Table

EN1	EN2	MODE
0	0	Shutdown
1	0	Indicator
0	1	Torch
1	1	Flash

8 Application and Implementation

NOTE

Information in the following applications sections is not part of the TI component specification, and TI does not warrant its accuracy or completeness. TI's customers are responsible for determining suitability of components for their purposes. Customers should validate and test their design implementation to confirm system functionality.

8.1 Application Information

The LM2758 can drive one flash LED at currents up to 700 mA. The multi-gain charge-pump boost regulator allows for the use of small value discrete external components.

8.2 Typical Application

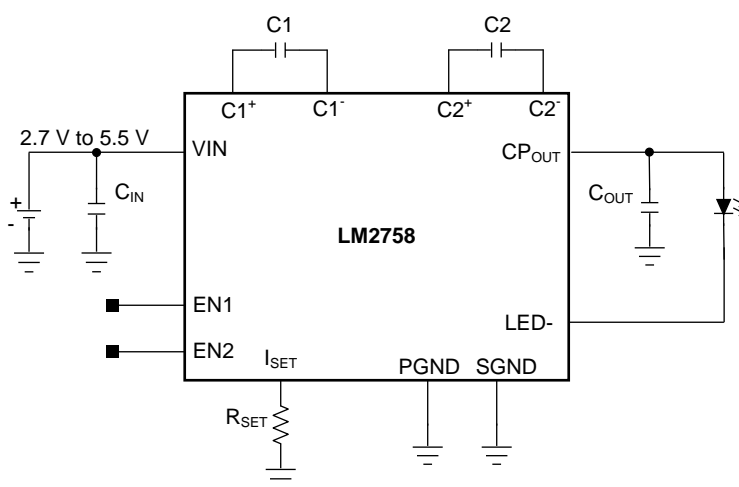

Copyright © 2016, Texas Instruments Incorporated

Figure 8. LM2758 Typical Application

8.2.1 Design Requirements

For typical switched-capacitor LED-driver applications, use the parameters listed in [Table 2](#).

Table 2. Design Parameters

DESIGN PARAMETER	EXAMPLE VALUE
Minimum input voltage	2.7 V
Maximum output current	700 mA

8.2.2 Detailed Design Procedure

8.2.2.1 Capacitor Selection

The LM2758 device requires 4 external capacitors for proper operation. Surface-mount multi-layer ceramic capacitors are recommended. These capacitors are small, inexpensive and have very low equivalent series resistance (ESR < 20 mΩ typical). Tantalum capacitors, OS-CON capacitors, and aluminum electrolytic capacitors are not recommended for use with the LM2758 due to their high ESR compared to ceramic capacitors. For most applications, ceramic capacitors with X7R or X5R temperature characteristic are preferred for use with the LM2758. Ceramic capacitors have tight capacitance tolerance (as good as ±10%) and hold their value over temperature (X7R: ±15% over –55°C to +125°C; X5R: ±15% over –55°C to +85°C). Capacitors with Y5V or Z5U temperature characteristic are generally not recommended for use with the LM2758. Capacitors with these temperature characteristics typically have wide capacitance tolerance (+80%, –20%) and vary significantly

over temperature (Y5V: 22%, –82% over –30°C to +85°C range; Z5U: 22%, –56% over 10°C to 85°C range). Under some conditions, a nominal 1 μF Y5V or Z5U capacitor could have a capacitance of only 0.1 μF . Such detrimental deviation is likely to cause Y5V and Z5U capacitors to fail to meet the minimum capacitance requirements of the LM2758. The voltage rating of the output capacitor must be 6.3 V or more. For example, a 6.3-V, 0603, 2.2- μF output capacitor (TDK C1608X5R0J225) is acceptable for use with the LM2758, as long as the capacitance on the output does not fall below a minimum of 1 μF in the intended application. All other capacitors must have a voltage rating at or above the maximum input voltage of the application and a minimum capacitance of 1 μF .

Table 3. Suggested Capacitors And Suppliers

MANUFACTURER PART NUMBER	TYPE	MANUFACTURER	VOLTAGE RATING	CASE SIZE INCH (mm)
2.2 μF for C_{IN} and C_{OUT}				
C1608X5R0J225	Ceramic X5R	TDK	6.3 V	0603 (1608)
JMK107BJ225	Ceramic X5R	Taiyo-Yuden	6.3 V	0603 (1608)
1 μF for C1 and C2				
C1608X5R0J105	Ceramic X5R	TDK	6.3 V	0603 (1608)
JMK107BJ105M	Ceramic X5R	Taiyo-Yuden	6.3 V	0603 (1608)

8.2.2.2 Power Efficiency

Efficiency of LED drivers is commonly taken to be the ratio of power consumed by the LEDs (P_{LED}) to the power drawn at the input of the part (P_{IN}). With a 1 \times /1.5 \times charge pump, the input current is equal to the charge pump gain times the output current (total LED current). The efficiency of the LM2758 can be predicted as follows:

$$P_{\text{LED}} = V_{\text{LED}} \times I_{\text{LED}} \quad (3)$$

$$P_{\text{IN}} = V_{\text{IN}} \times I_{\text{IN}} \quad (4)$$

$$P_{\text{IN}} = V_{\text{IN}} \times (\text{Gain} \times I_{\text{LED}} + I_{\text{Q}}) \quad (5)$$

$$E = (P_{\text{LED}} \div P_{\text{IN}}) \quad (6)$$

For a simple approximation, the current consumed by internal circuitry (I_{Q}) can be neglected, and the resulting efficiency will become:

$$E = V_{\text{LED}} \div (V_{\text{IN}} \times \text{Gain}) \quad (7)$$

Neglecting I_{Q} results in a slightly higher efficiency prediction, but this impact will be negligible due to the value of I_{Q} being very low compared to the typical torch and flash current levels (100 mA to 500 mA). It is also worth noting that efficiency as defined here is in part dependent on LED voltage. Variation in LED voltage does not affect power consumed by the circuit and typically does not relate to the brightness of the LED. For an advanced analysis, it is recommended that power consumed by the circuit ($V_{\text{IN}} \times I_{\text{IN}}$) be evaluated rather than power efficiency.

8.2.3 Application Curves

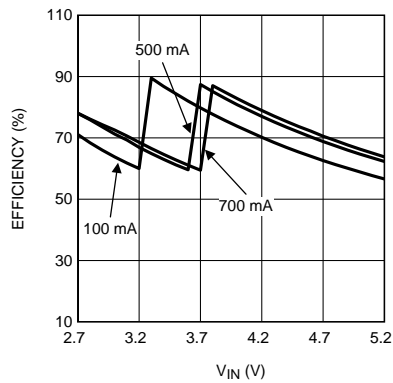
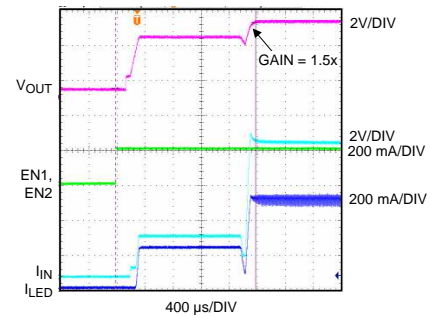
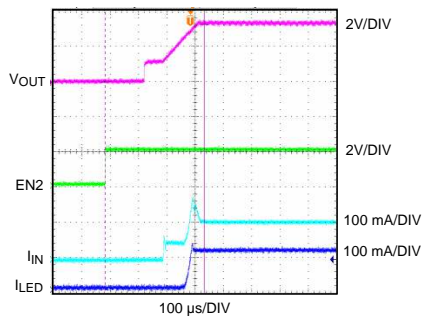

Figure 9. Efficiency vs V_{IN}



$V_{IN} = 3.6\text{ V}$ $I_{LED} = 500\text{ mA}$

Figure 10. Shutdown to Flash Mode



$V_{IN} = 3.6\text{ V}$ $I_{LED} = 108\text{ mA}$ Gain = 1x
 $EN1 = 0\text{ V}$

Figure 11. Shutdown to Torch Mode

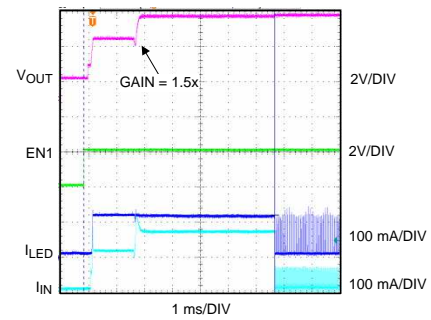

$V_{IN} = 3.6\text{ V}$ $I_{LED} (\text{torch}) = 108\text{ mA}$
 $EN2 = 0\text{ V}$

Figure 12. Shutdown to Indicator Mode

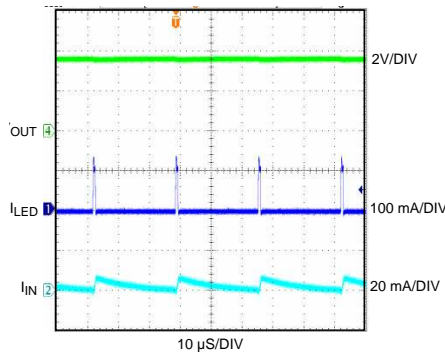

$EN1 = V_{IN} = 3.6\text{ V}$ $I_{LED} (\text{torch}) = 108\text{ mA}$ Gain = 1x
 $EN2 = 0\text{ V}$

Figure 13. Indicator Mode

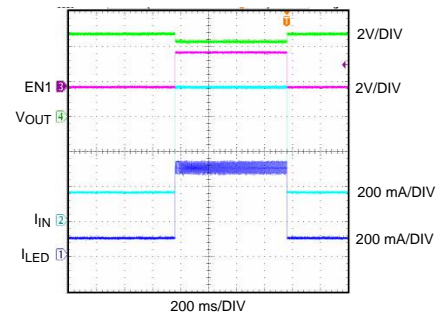

$EN2 = V_{IN} = 3.6\text{ V}$ $I_{LED} (\text{flash}) = 500\text{ mA}$ Gain = 1.5x

Figure 14. Torch to Flash Mode Transition

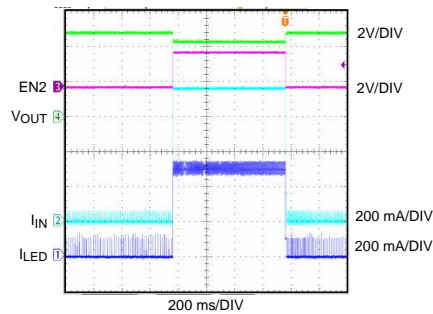

$$EN1 = V_{IN} = 3.6 \text{ V}$$

$$I_{LED} (\text{flash}) = 500 \text{ mA}$$

$$\text{Gain} = 1.5\times$$

Figure 15. Indicator to Flash Mode Transition

9 Power Supply Recommendations

The LM2758 is designed to operate from an input voltage supply range from 2.7 V to 5.5 V. This input supply must be well regulated and capable to supply the required input current. If the input supply is located far from the device, additional bulk capacitance may be required in addition to the ceramic bypass capacitors.

9.1 Power Dissipation

The power dissipation ($P_{\text{DISSIPATION}}$) and junction temperature (T_J) can be approximated with the equations below. P_{IN} is the power generated by the 1x/1.5x charge pump, P_{LED} is the power consumed by the LEDs, T_A is the ambient temperature, and $R_{\theta\text{JA}}$ is the junction-to-ambient thermal resistance for the 12-pin DSBGA package. V_{IN} is the input voltage to the LM2758, V_{LED} is the nominal LED forward voltage, and I_{LED} is the programmed LED current.

$$P_{\text{DISSIPATION}} = P_{\text{IN}} - P_{\text{LED}} \quad (8)$$

$$= (\text{Gain} \times V_{\text{IN}} \times I_{\text{LED}}) - (V_{\text{LED}} \times I_{\text{LED}}) \quad (9)$$

$$T_J = T_A + (P_{\text{DISSIPATION}} \times R_{\theta\text{JA}}) \quad (10)$$

The junction temperature rating takes precedence over the ambient temperature rating. The LM2758 may be operated outside the ambient temperature rating, so long as the junction temperature of the device does not exceed the maximum operating rating of 125°C. The maximum ambient temperature rating must be derated in applications where high power dissipation and/or poor thermal resistance causes the junction temperature to exceed 125°C.

10 Layout

10.1 Layout Guidelines

PC board layout is an important part of DC-DC converter design. Poor board layout can disrupt the performance of a DC-DC converter and surrounding circuitry by contributing to EMI, ground bounce, and resistive voltage loss in the traces. These can send erroneous signals to the DC-DC converter device, resulting in poor regulation or instability. Poor layout can also result in re-flow problems leading to poor solder joints between the DSBGA package and board pads. Poor solder joints can result in erratic or degraded performance.

10.2 Layout Example

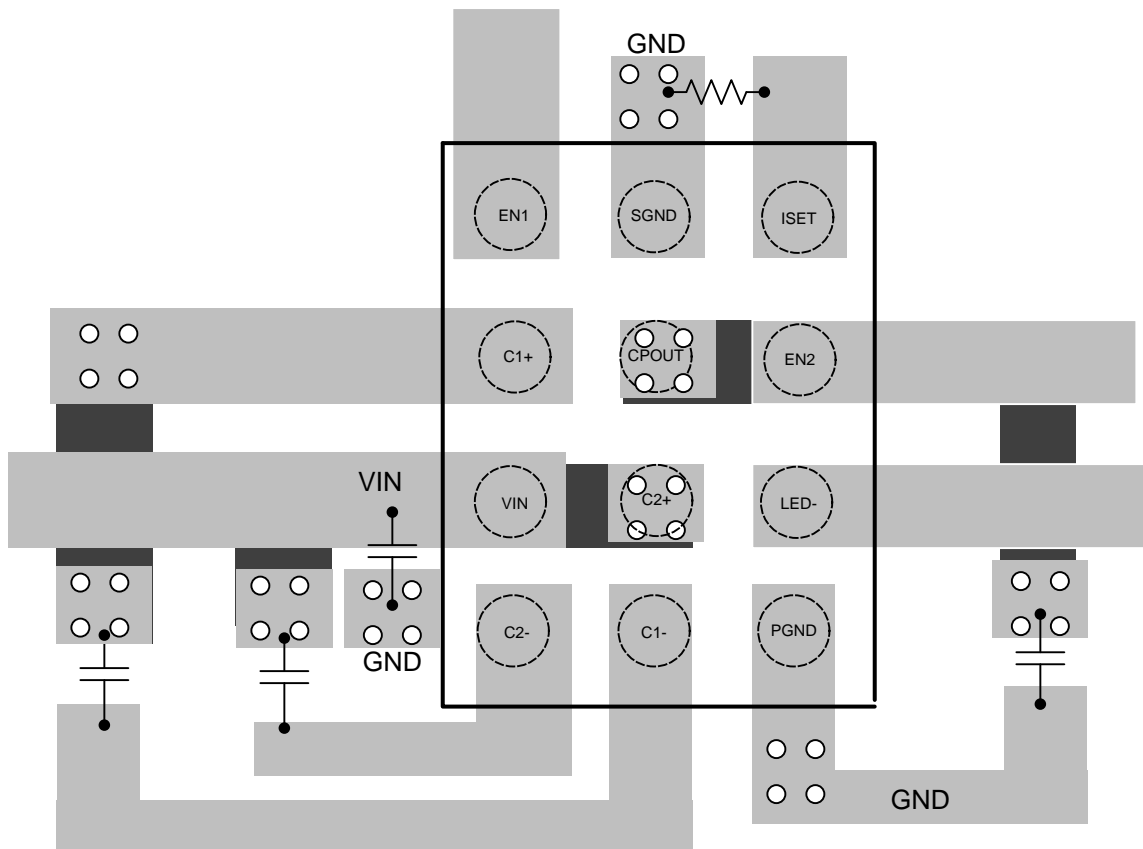

Figure 16. LM2758 Layout Example

10.3 DSBGA Package Assembly and Use

Use of the DSBGA package requires specialized board layout, precision mounting and careful re-flow techniques as detailed in *AN-1112 DSBGA Wafer Level Chip Scale Package (SNVA009)*. Refer to the section *Surface Mount Assembly Considerations* for best results in assembly, use alignment ordinals on the PC board to facilitate placement of the device. The pad style used with the DSBGA package must be the NSMD (non-solder mask defined) typical. This means that the solder-mask opening is larger than the pad size. This prevents a lip that otherwise forms if the solder mask and pad overlap, from holding the device off the surface of the board and interfering with mounting. See [SNVA009](#) for specific instructions how to do this. The 12-pin package used for LM2758 has 300 micron solder balls and requires 10.82 mils pads for mounting on the circuit board. The trace to each pad should enter the pad with a 90° entry angle to prevent debris from being caught in deep corners. Initially, the trace to each pad should be 7 mil. wide, for a section approximately 7 mil. long or longer, as a thermal relief. Then each trace should neck up or down to its optimal width. The important criteria is symmetry. This ensures the solder bumps on the LM2758 re-flow evenly and that the device solders level to the board. In particular, special attention must be paid to the pads for bumps C1 and D3, because VIN and GND are typically connected to large copper planes, thus inadequate thermal relief can result in late or inadequate re-flow of these bumps.

The DSBGA package is optimized for the smallest possible size in applications with red or infrared opaque cases. Because the DSBGA package lacks the plastic encapsulation characteristic of larger devices, it is vulnerable to light. Backside metallization and/or epoxy coating, along with front side shading by the printed circuit board, reduce this sensitivity. However, the package has exposed die edges. In particular, DSBGA devices are sensitive to light, in the red and infrared range, shining on the exposed die edges of the package.

11 Device and Documentation Support

11.1 Device Support

11.1.1 Third-Party Products Disclaimer

TI'S PUBLICATION OF INFORMATION REGARDING THIRD-PARTY PRODUCTS OR SERVICES DOES NOT CONSTITUTE AN ENDORSEMENT REGARDING THE SUITABILITY OF SUCH PRODUCTS OR SERVICES OR A WARRANTY, REPRESENTATION OR ENDORSEMENT OF SUCH PRODUCTS OR SERVICES, EITHER ALONE OR IN COMBINATION WITH ANY TI PRODUCT OR SERVICE.

11.2 Documentation Support

11.2.1 Related Documentation

For additional information, see the following:

AN-1112 DSBGA Wafer Level Chip Scale Package ([SNVA009](#))

11.3 Community Resources

The following links connect to TI community resources. Linked contents are provided "AS IS" by the respective contributors. They do not constitute TI specifications and do not necessarily reflect TI's views; see TI's [Terms of Use](#).

TI E2E™ Online Community *TI's Engineer-to-Engineer (E2E) Community*. Created to foster collaboration among engineers. At [e2e.ti.com](#), you can ask questions, share knowledge, explore ideas and help solve problems with fellow engineers.

Design Support *TI's Design Support* Quickly find helpful E2E forums along with design support tools and contact information for technical support.

11.4 Trademarks

E2E is a trademark of Texas Instruments.
All other trademarks are the property of their respective owners.

11.5 Electrostatic Discharge Caution



This integrated circuit can be damaged by ESD. Texas Instruments recommends that all integrated circuits be handled with appropriate precautions. Failure to observe proper handling and installation procedures can cause damage.

ESD damage can range from subtle performance degradation to complete device failure. Precision integrated circuits may be more susceptible to damage because very small parametric changes could cause the device not to meet its published specifications.

11.6 Glossary

[SLYZ022](#) — *TI Glossary*.

This glossary lists and explains terms, acronyms, and definitions.

12 Mechanical, Packaging, and Orderable Information

The following pages include mechanical, packaging, and orderable information. This information is the most current data available for the designated devices. This data is subject to change without notice and revision of this document. For browser-based versions of this data sheet, refer to the left-hand navigation.

PACKAGING INFORMATION

Orderable Device	Status (1)	Package Type	Package Drawing	Pins	Package Qty	Eco Plan (2)	Lead/Ball Finish (6)	MSL Peak Temp (3)	Op Temp (°C)	Device Marking (4/5)	Samples
LM2758TL/NOPB	ACTIVE	DSBGA	YZR	12	250	Green (RoHS & no Sb/Br)	SNAGCU	Level-1-260C-UNLIM	-40 to 85	2758	Samples
LM2758TLX/NOPB	ACTIVE	DSBGA	YZR	12	3000	Green (RoHS & no Sb/Br)	SNAGCU	Level-1-260C-UNLIM	-40 to 85	2758	Samples

(1) The marketing status values are defined as follows:

ACTIVE: Product device recommended for new designs.

LIFEBUY: TI has announced that the device will be discontinued, and a lifetime-buy period is in effect.

NRND: Not recommended for new designs. Device is in production to support existing customers, but TI does not recommend using this part in a new design.

PREVIEW: Device has been announced but is not in production. Samples may or may not be available.

OBsolete: TI has discontinued the production of the device.

(2) Eco Plan - The planned eco-friendly classification: Pb-Free (RoHS), Pb-Free (RoHS Exempt), or Green (RoHS & no Sb/Br) - please check <http://www.ti.com/productcontent> for the latest availability information and additional product content details.

TBD: The Pb-Free/Green conversion plan has not been defined.

Pb-Free (RoHS): TI's terms "Lead-Free" or "Pb-Free" mean semiconductor products that are compatible with the current RoHS requirements for all 6 substances, including the requirement that lead not exceed 0.1% by weight in homogeneous materials. Where designed to be soldered at high temperatures, TI Pb-Free products are suitable for use in specified lead-free processes.

Pb-Free (RoHS Exempt): This component has a RoHS exemption for either 1) lead-based flip-chip solder bumps used between the die and package, or 2) lead-based die adhesive used between the die and leadframe. The component is otherwise considered Pb-Free (RoHS compatible) as defined above.

Green (RoHS & no Sb/Br): TI defines "Green" to mean Pb-Free (RoHS compatible), and free of Bromine (Br) and Antimony (Sb) based flame retardants (Br or Sb do not exceed 0.1% by weight in homogeneous material)

(3) MSL, Peak Temp. - The Moisture Sensitivity Level rating according to the JEDEC industry standard classifications, and peak solder temperature.

(4) There may be additional marking, which relates to the logo, the lot trace code information, or the environmental category on the device.

(5) Multiple Device Markings will be inside parentheses. Only one Device Marking contained in parentheses and separated by a "~" will appear on a device. If a line is indented then it is a continuation of the previous line and the two combined represent the entire Device Marking for that device.

(6) Lead/Ball Finish - Orderable Devices may have multiple material finish options. Finish options are separated by a vertical ruled line. Lead/Ball Finish values may wrap to two lines if the finish value exceeds the maximum column width.

Important Information and Disclaimer: The information provided on this page represents TI's knowledge and belief as of the date that it is provided. TI bases its knowledge and belief on information provided by third parties, and makes no representation or warranty as to the accuracy of such information. Efforts are underway to better integrate information from third parties. TI has taken and continues to take reasonable steps to provide representative and accurate information but may not have conducted destructive testing or chemical analysis on incoming materials and chemicals. TI and TI suppliers consider certain information to be proprietary, and thus CAS numbers and other limited information may not be available for release.

In no event shall TI's liability arising out of such information exceed the total purchase price of the TI part(s) at issue in this document sold by TI to Customer on an annual basis.

TAPE AND REEL INFORMATION

QUADRANT ASSIGNMENTS FOR PIN 1 ORIENTATION IN TAPE

*All dimensions are nominal

Device	Package Type	Package Drawing	Pins	SPQ	Reel Diameter (mm)	Reel Width W1 (mm)	A0 (mm)	B0 (mm)	K0 (mm)	P1 (mm)	W (mm)	Pin1 Quadrant
LM2758TL/NOPB	DSBGA	YZR	12	250	178.0	8.4	1.68	2.13	0.76	4.0	8.0	Q1
LM2758TLX/NOPB	DSBGA	YZR	12	3000	178.0	8.4	1.68	2.13	0.76	4.0	8.0	Q1

TAPE AND REEL BOX DIMENSIONS

*All dimensions are nominal

Device	Package Type	Package Drawing	Pins	SPQ	Length (mm)	Width (mm)	Height (mm)
LM2758TL/NOPB	DSBGA	YZR	12	250	210.0	185.0	35.0
LM2758TLX/NOPB	DSBGA	YZR	12	3000	210.0	185.0	35.0

YZR0012

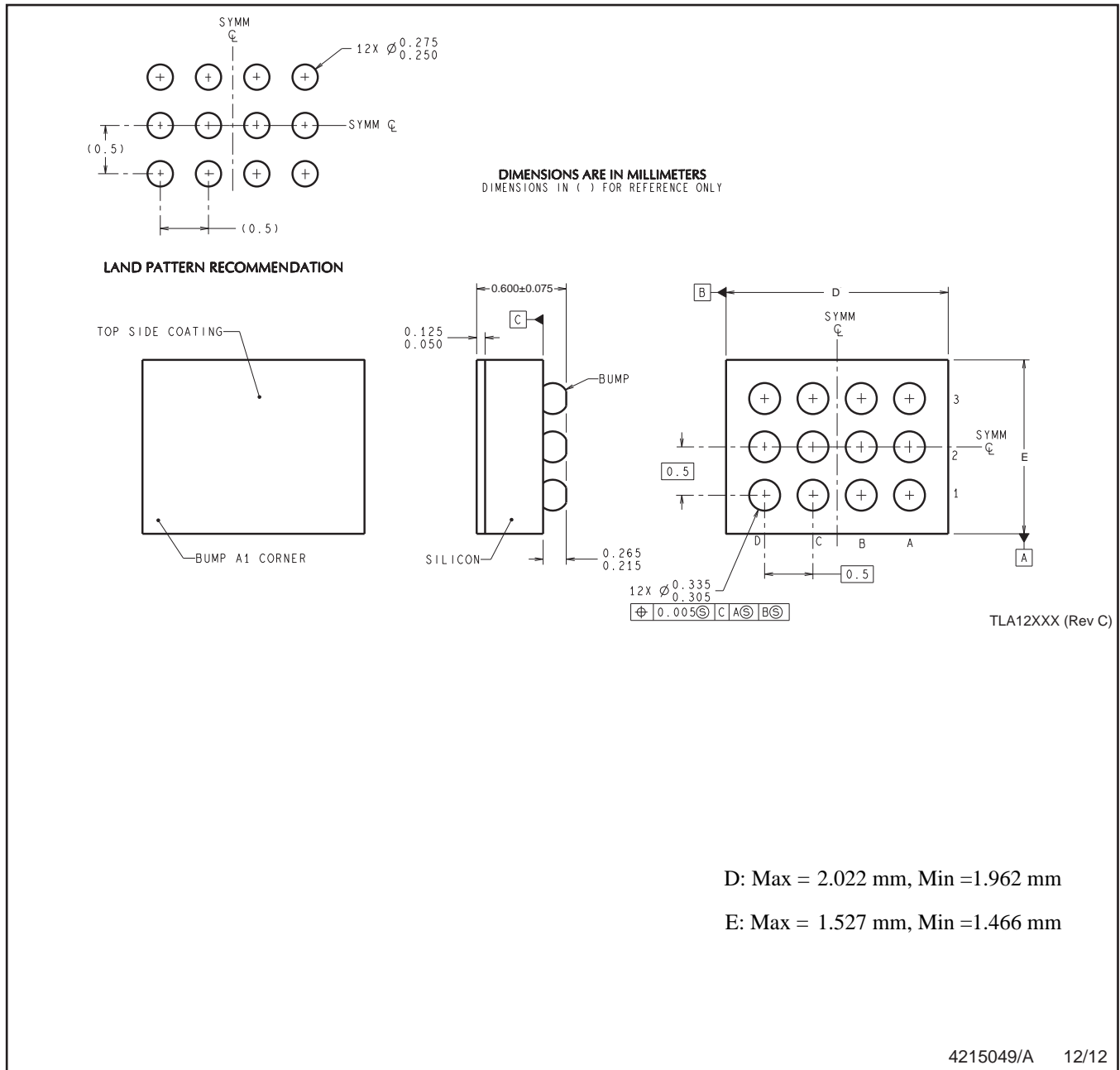

NOTES: A. All linear dimensions are in millimeters. Dimensioning and tolerancing per ASME Y14.5M-1994.
B. This drawing is subject to change without notice.

IMPORTANT NOTICE AND DISCLAIMER

TI PROVIDES TECHNICAL AND RELIABILITY DATA (INCLUDING DATASHEETS), DESIGN RESOURCES (INCLUDING REFERENCE DESIGNS), APPLICATION OR OTHER DESIGN ADVICE, WEB TOOLS, SAFETY INFORMATION, AND OTHER RESOURCES "AS IS" AND WITH ALL FAULTS, AND DISCLAIMS ALL WARRANTIES, EXPRESS AND IMPLIED, INCLUDING WITHOUT LIMITATION ANY IMPLIED WARRANTIES OF MERCHANTABILITY, FITNESS FOR A PARTICULAR PURPOSE OR NON-INFRINGEMENT OF THIRD PARTY INTELLECTUAL PROPERTY RIGHTS.

These resources are intended for skilled developers designing with TI products. You are solely responsible for (1) selecting the appropriate TI products for your application, (2) designing, validating and testing your application, and (3) ensuring your application meets applicable standards, and any other safety, security, or other requirements. These resources are subject to change without notice. TI grants you permission to use these resources only for development of an application that uses the TI products described in the resource. Other reproduction and display of these resources is prohibited. No license is granted to any other TI intellectual property right or to any third party intellectual property right. TI disclaims responsibility for, and you will fully indemnify TI and its representatives against, any claims, damages, costs, losses, and liabilities arising out of your use of these resources.

TI's products are provided subject to TI's Terms of Sale (www.ti.com/legal/termsofsale.html) or other applicable terms available either on ti.com or provided in conjunction with such TI products. TI's provision of these resources does not expand or otherwise alter TI's applicable warranties or warranty disclaimers for TI products.

Mailing Address: Texas Instruments, Post Office Box 655303, Dallas, Texas 75265
Copyright © 2019, Texas Instruments Incorporated

Looking for pricing, stock, or lifecycle information?

Click below to explore more details on WIN SOURCE:

 [View LM2758TLEV](#) on WIN SOURCE

 [Texas Instruments](#) Information

Optimize Your Supply Chain with WIN SOURCE Solutions

-  Global Sourcing Solution
-  Obsolete Management
-  Cost Control Management
-  Shortage Management
-  Alternative Solution
-  Excess Inventory Management