



**THE DATASHEET OF
EVAL-AD5933EBZ**



Evaluating the **AD5933** 1 MSPS, 12-Bit Impedance Converter Network Analyzer

FEATURES

- Full-featured evaluation board for the **AD5933**
- Graphic user interface software with frequency sweep capability for board control and data analysis
- Various power supply linking options
- Standalone capability with serial I²C loading from on-board microcontroller
- Selectable system clock options including internal RC oscillator or on-board 16 MHz crystal

APPLICATIONS

- Electrochemical analysis
- Impedance spectroscopy
- Complex impedance measurement
- Corrosion monitoring and protection equipment
- Biomedical and automotive sensors
- Proximity sensing

GENERAL DESCRIPTION

This user guide describes the [EVAL-AD5933EBZ](#) evaluation board, and the application software developed to interface with the device. The **AD5933** is a high precision impedance converter system that combines an on-board frequency generator with a 12-bit, 1 MSPS analog-to-digital converter (ADC). The frequency generator allows an external complex impedance to be excited with a

known frequency. The on-board ADC samples the response signal from the impedance, and an on-board DSP engine at each excitation frequency processes the DFT. The **AD5933** also contains an internal temperature sensor with 13-bit resolution. The part operates from a 2.7 V to 5.5 V supply. Other on-board components include a **ADR423** 3.0 V reference to act as a stable supply voltage for the separate analog and digital sections of the device and a **ADP3303** ultrahigh precision regulator to act as a supply to the on-board universal serial bus controller that interfaces to the **AD5933**. The user has the option to power the entire circuitry from the USB port of a computer.

The evaluation board also has a high performance trimmed 16 MHz surface-mount crystal to act as a system clock to the **AD5933**, if required. The various link options located around the evaluation board are listed in Table 1. Interfacing to the **AD5933** is through a USB microcontroller that generates the I²C signals necessary to communicate with the **AD5933**. Interfacing to the USB microcontroller is done through a Visual Basic[®] graphic user interface located on and run from the PC. Complete specifications for the **AD5933** are available in the **AD5933** data sheet available from Analog Devices, Inc., and should be consulted in conjunction with this user guide when using the evaluation board.

EVALUATION BOARD BLOCK DIAGRAM

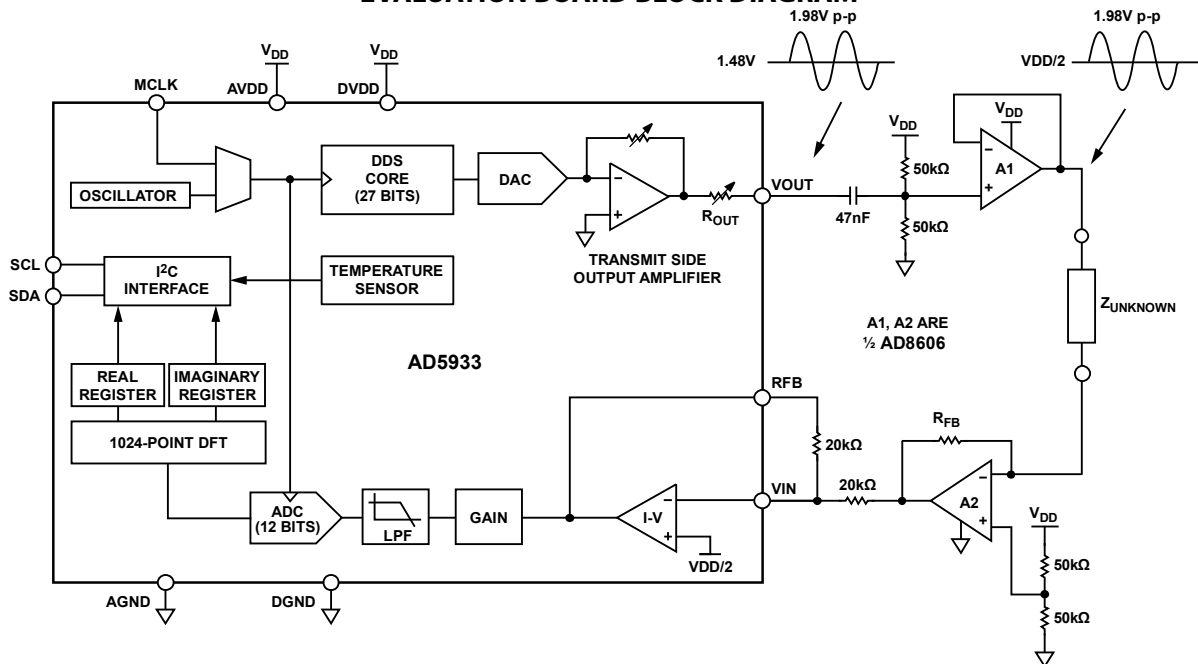

Figure 1.

10441-001

TABLE OF CONTENTS

Features	1	Performing a Frequency Sweep	6
Applications	1	Two Installation Frequently Asked Questions	10
General Description	1	Source Code for Impedance Sweep	12
Evaluation Board Block Diagram	1	Evaluation Board Source Code Extract	13
Revision History	2	Gain Factor Calculation	17
Evaluation Board Hardware	3	Temperature Measurement	17
Terminal Block Functions	3	Impedance Measurement Tips	18
Getting Started	4	Evaluation Board Schematics and Artwork	23
Setup Sequence Summary	4	Ordering Information	26
Installing the Software	4	Bill of Materials	26
Connecting the USB Cable	5	Related Links	27
Verifying the Links and Power Up the Evaluation Board	6		

REVISION HISTORY

2/12—Revision 0: Initial Version

EVALUATION BOARD HARDWARE

TERMINAL BLOCK FUNCTIONS

Table 1. Link Functions

Link No.	Default Location	Function
LK1	Out	Option to remove external conditioning
LK2	Out	Option to remove external conditioning
LK3	In	On-board, 16 MHz crystal connection, connects to Y2
LK4	Out	SMB connected external clock
LK5	In	Connects 5 V from USB to ADP3303
LK6	A	AVDD and DVDD power supply connector

GETTING STARTED

SETUP SEQUENCE SUMMARY

The evaluation board installation instructions are for the Windows XP® operating system with English (United States) set for its language. The regional and language settings of a PC can be changed in the **Regional and Language** directory within the **Control Panel (Start/Control Panel/Regional and Language/Formats)**. The installation consists of the following steps that are described in detail in the sections that follow.

1. Install the **AD5933** graphical user interface software on the CD that accompanies the evaluation board. Do not connect the USB cable from the **AD5933** evaluation board to the computer USB hub until the evaluation software is properly installed. See the Installing the Software section for additional information.
2. Connect the computer USB port to the evaluation board using the USB cable provided in the evaluation kit and run the USB hardware installation wizard after the evaluation software is correctly installed (the hardware installation may happen automatically depending on the settings of the current operating system). See the Connecting the USB Cable section for additional information.
3. Ensure that the appropriate links are made throughout the evaluation board. Prior to opening and running the evaluation software program, power up the evaluation board appropriately. See the Verifying the Links and Power Up section for additional information.
4. Configure the front panel of the evaluation board software to run the required sweep function. See the Performing a Frequency Sweep section for additional information.

INSTALLING THE SOFTWARE

To install the evaluation board software, use the following steps:

1. Put the evaluation board CD into the CD drive of the PC and click **Start/My Computer**.
2. The CD software installation may happen automatically after the CD is inserted into the CD drive; however, this may depend on the settings of the current operating system. If the software installation does not automatically start, go to **AD5933 Installation/Setup.exe** and double-click **Setup.exe** to install the software on the PC through the installation wizard (see Figure 2 and Figure 3).



Figure 2. Evaluation Software CD Contents

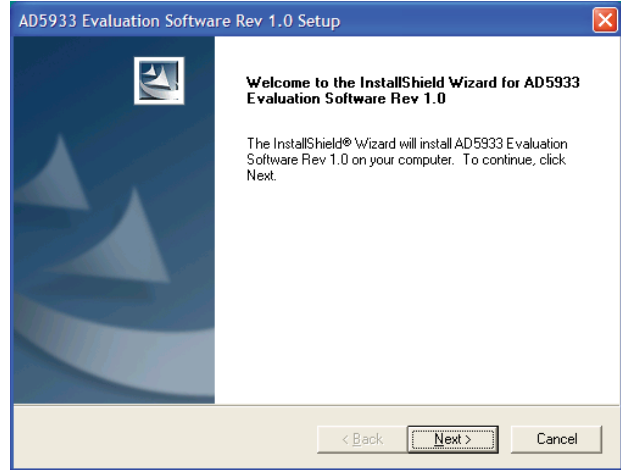

Figure 3. Installation Wizard

3. Install the evaluation board software in the default destination folder path, **C:\Program Files\Analog Devices\AD5933\AD5933 Evaluation Software Rev 1.0 Setup** (see Figure 4).

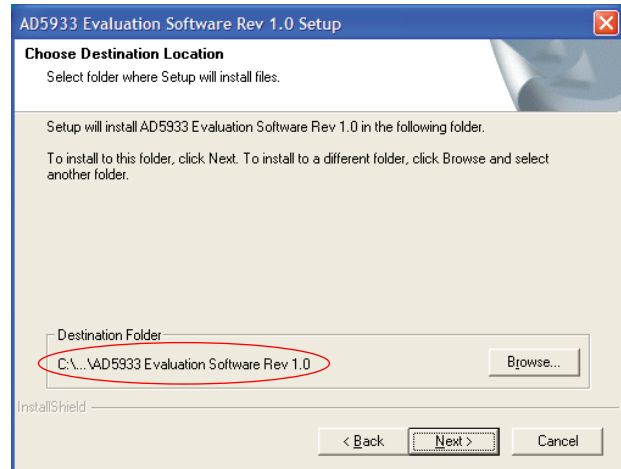

Figure 4. Default Destination Folder

- Choose the **Analog Devices** directory (see Figure 5). If the **Analog Devices** folder does not yet exist, create an **Analog Devices** folder and add the program icon to this new folder.

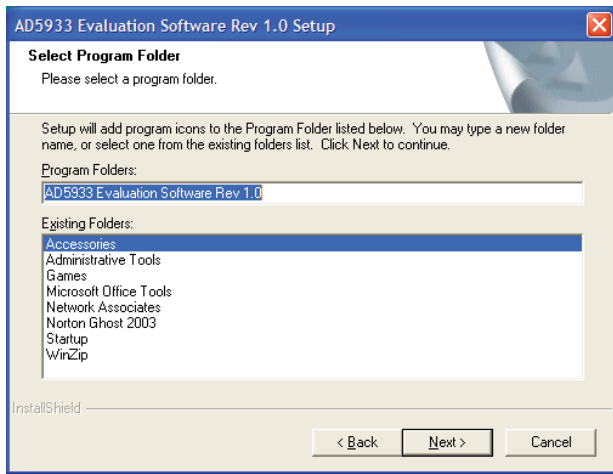

Figure 5. Select Analog Devices Directory

- After installing the software, remove the CD from the CD drive. You may be asked to reboot the computer at this stage.
- Go to **Start/All Programs/Analog Devices/AD5933/AD5933** (see Figure 6).

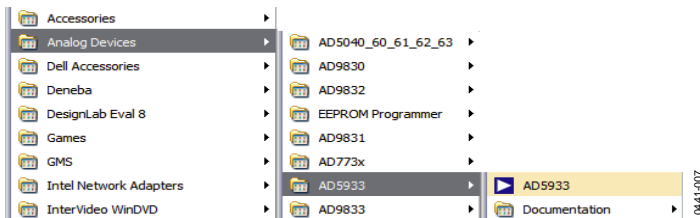

Figure 6. Opening the Evaluation Software

The following message appears (see Figure 7) because the firmware code that the evaluation software operates from, and that needs to be downloaded to the evaluation board USB microcontroller memory each time the interface software program is opened, cannot be successfully downloaded to the evaluation board. The error message is presented because there is currently no USB connection between the computer and the AD5933 evaluation board at this stage; therefore, this error message is to be expected. Click **Cancel**.

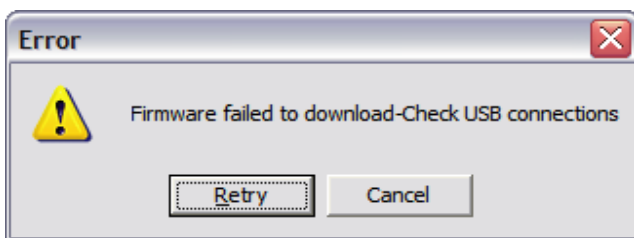

Figure 7. Expected Error Message

CONNECTING THE USB CABLE

To connect the USB cable, use the following steps:

- Plug the USB cable into the USB hub of the PC and connect the other end of the USB cable into the AD5933 evaluation board USB socket (see J1 in Figure 32). A message may appear that a USB device has been detected on the host computer and that new hardware has been found (see Figure 8).



Figure 8. USB Device Detected by Host Computer

- The **Found New Hardware Wizard** then appears (see Figure 9). This wizard locates and installs the appropriate driver files for the AD5933 evaluation kit in the operating system registry. Select **Install the software automatically (Recommended)** and click **Next >** to continue (see Figure 9).



Figure 9. Hardware Installation Wizard

- A standard windows operating system warning message then appears, as shown in Figure 10. It indicates that the new hardware currently being installing on the Windows® operating system (AD5933 evaluation kit) has not passed the Windows logo testing to verify compatibility with Windows XP. This warning appears because the installation is an evaluation setup installation and is not intended to be used in a production environment. Click **Continue Anyway** and then click **Finish**.



Figure 10. Expected Warning Message

The message shown in Figure 11 appears once the hardware has been successfully installed.

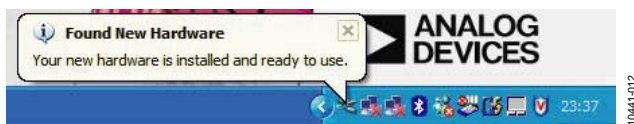

Figure 11. Successful Hardware Installation

VERIFYING THE LINKS AND POWER UP THE EVALUATION BOARD

Ensure that the relevant links are in place on the evaluation board (see Table 1) and that the proper power connections and supply values have been made to the terminal blocks before applying power to the evaluation board. The power supply terminal blocks are outlined in evaluation board schematic (see Figure 32). Note that the USB connector only supplies power to the Cypress USB controller chip that interfaces to the AD5933. If required, a dedicated external voltage supply to each terminal block can be provided. Ensure that all relevant power supply connections and links are made before running the evaluation software. For optimum performance, supply the three supply signals (A_{VDD1} , A_{VDD2} , and D_{VDD}) from a stable external reference supply via the power supply terminal blocks on the board.

PERFORMING A FREQUENCY SWEEP

The sequence for performing a linear frequency sweep across a 200 k Ω resistive impedance connected across the VOUT and VIN pins within the frequency range of 30 kHz to 30.2 kHz is outlined in this section. The default software settings for the evaluation board are shown in Figure 12. (Note that a 200 k Ω resistor must be connected across the VIN and VOUT pins of the AD5933). The default link positions are outlined in Table 1, see this before continuing.

To open the software, go to **Start > Programs > Analog Devices > AD5933** and click **AD5933 Evaluation Software**.

Figure 12 shows the graphic user interface program open and running successfully. It also shows the interface panel along with a frequency sweep impedance profile for a 200 k Ω resistive impedance (note $R_{FB} = 200\text{ k}\Omega$).

To setup a typical sweep across a 200 k Ω impedance ($R_{FB} = 200\text{ k}\Omega$), use the following steps:

- Set **Start Frequency (Hz)** to 30000 (Hz) within the **Sweep Parameters** section (see 1 in Figure 12). The start frequency is 24-bit accurate.
- Set **Delta Frequency (Hz)** to 2 (Hz) within the **Sweep Parameters** section (see 1 in Figure 12). The frequency step size is also 24-bit accurate.
- Set **Number Increments (9 Bit)** within the **Sweep Parameters** section to 200 (see 1 in Figure 12) to set the number of increments along the sweep to 200. The maximum number of increments that the device can sweep across is 511, and the value is stored in a register as a 9-bit value.
- Set **Number of Settling Time Cycles** to 15 (see 1 in Figure 12).

Note that when sweeping across a high-Q structure, such as resonant impedance, users must ensure that the contents of the settling time cycles register is sufficient to ensure that the impedance under test settles before incrementing between each successive frequency in the programmed sweep. This is achieved by increasing the **Number of Settling Time Cycles** value.

The delay between the time a frequency increment takes place on the output of the internal direct digital synthesizer (DDS) core and the time the ADC samples the response signal at this new frequency is determined by the contents of the number of settling time cycles registers (Register 0x8A and Register 0x8B), see the AD5933 data sheet for further details. For example, if a value of 15 is programmed into the **Number of Settling Time Cycles** box, and if the next output frequency is 32 kHz, the delay between the time the DDS core starts to output the 32 kHz signal and the time the ADC samples the response signal is $15 \times (1/32\text{ kHz}) \approx 468.7\text{ }\mu\text{s}$. The maximum number of settling time cycle delays that can be programmed to the board is 511 cycles. The value is stored in a register as a 9-bit value, and this value can be further multiplied by a factor of 2 or by a factor of 4.

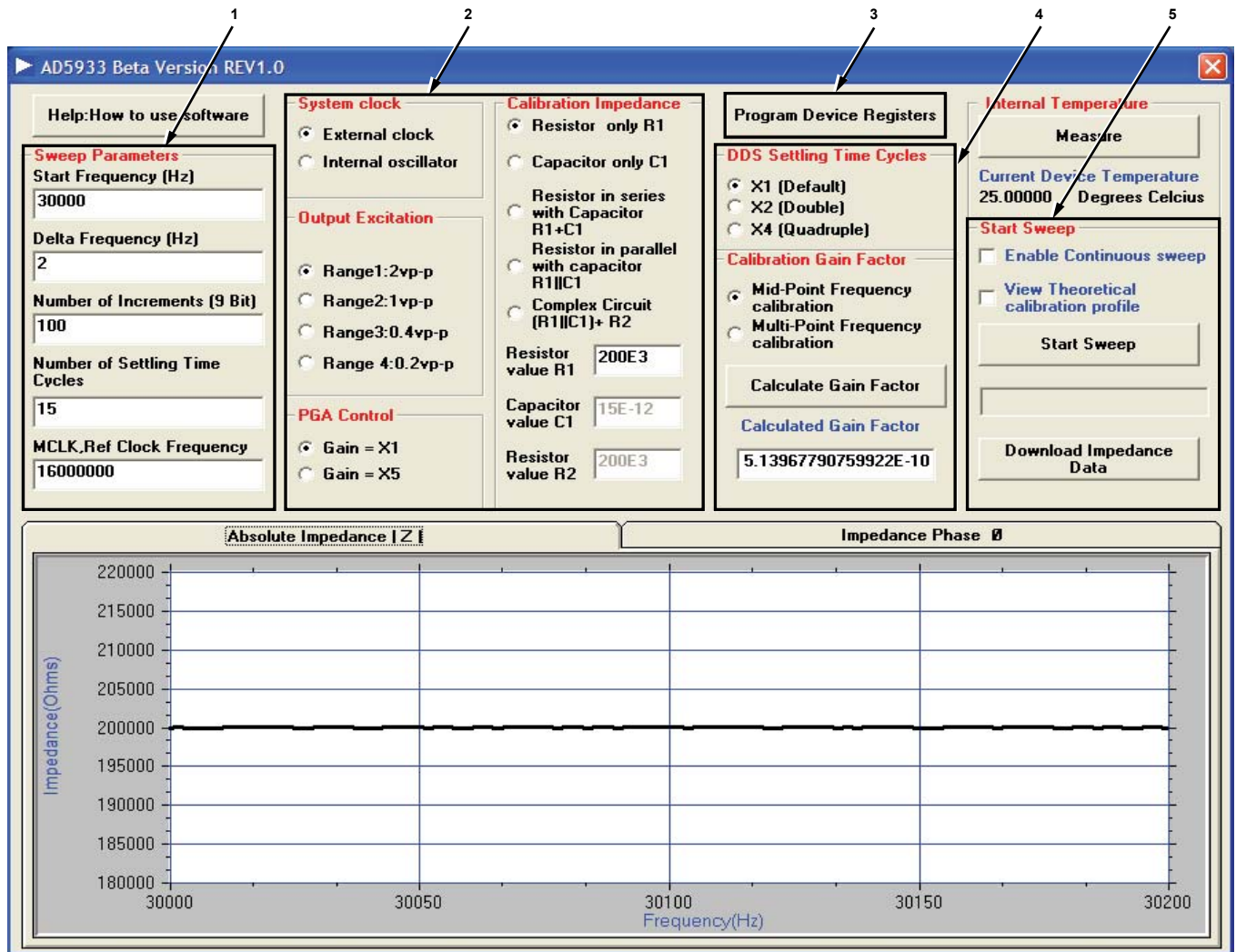

Figure 12. AD5933 Evaluation Software Front Panel (Impedance Profile of 200 kΩ Resistor Displayed)

- Choose the external clock as the system clock. Select **External clock** in the **System Clock** section (see 2 in Figure 12).
 - Set **Output Excitation** voltage range of the **AD5933** at Pin 6 (VOUT) to **Range1:2v p-p** (see 2 in Figure 12). The four possible output ranges available are 2 V p-p, 1 V p-p, 0.4 V p-p, or 0.2 V p-p, typically.
 - Set the PGA gain of the ADC on the receive stage (either $\times 1$ or $\times 5$) in the **PGA Control** section to $\times 1$ (see 2 in Figure 12).
 - Refer to the **Calibration Impedance** panel (see 2 in Figure 12). Prior to making any measurements, calibrate the **AD5933** with a known (that is, accurately measured) calibration impedance connected between the VIN and VOUT pins of the **AD5933**. The choice of calibration impedance topology (for example, R1 in series with C1, R1 in parallel with C1) depends on the application in question. However, ensure that each component of the measured calibration impedance is entered correctly into each chosen topology component text box (see 2 in Figure 12). For this example, **Resistor only R1** was chosen in the **Calibration Impedance** section, that is, to measure the impedance of a 200 kΩ resistive impedance across frequency. Also for this example, set **Resistor value R1** to 200E3 (Ω).
 - Click **Program Device Registers** (see 3 in Figure 12) to program the sweep parameters as previously chosen into the appropriate on-board registers of the **AD5933** through the I²C interface.
 - The value programmed into the settling time cycles can be further multiplied by a factor of 2 or a factor of 4 for a sweep. Select **$\times 1$ (Default)** in the **DDS Settling Time Cycles** section.
 - Now that the frequency sweep parameters and gain settings are programmed, the next step is to calibrate the **AD5933** system by calculating the gain factor.
- The explanation of the system calibration gain factor, a term calculated once at system calibration, is provided in detail in the **AD5933** data sheet. The **AD5933** gain factor must be calibrated correctly for a particular impedance range before any subsequent valid impedance measurement (refer to the **AD5933** data sheet for further details).

- To automatically calculate the gain factor(s) for the subsequent sweep, click **Calculate Gain Factor**. The evaluation software evaluates either a single midpoint frequency gain factor or multipoint frequency gain factors, that is, a gain factor for each point in the programmed sweep (see 4 in Figure 12). The midpoint gain factor is determined at the midpoint of the programmed sweep, and the multipoint gain factors are determined at each point in the programmed frequency sweep.

When either the midpoint gain factor or the multipoint gain factors are calculated, a message appears on the evaluation board software front panel, as shown in Figure 13. The gain factor(s) returned to the evaluation software are subsequently used for the sweep across the impedance under test.

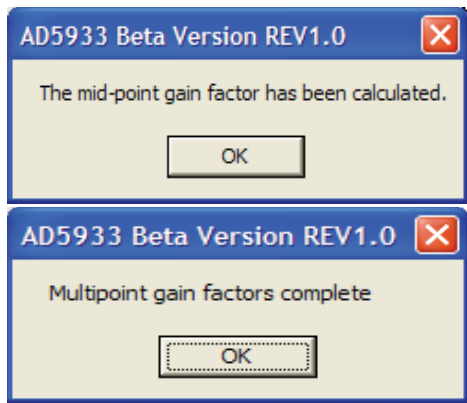

Figure 13. Confirmation of a Midpoint Calculation or a Multipoint Gain Factors Calculation

After the system interface software calculates the gain factor(s) for the programmed sweep parameters, the results are shown in the **Calculated Gain Factor** box.

Note that should any of the system gain settings (for example, change in output excitation range or PGA gain) change after the system is calibrated (that is, gain factor(s) are calculated), it is necessary to recalculate the gain factor(s) to subsequently measure accurate impedance results. The gain factor(s) calculated in the software are not programmed into the AD5933 RAM and are only valid when the evaluation software program is open and running. The gain factor(s) are not retained in the evaluation software when the software program is closed.

- Click **Start Sweep** (see 5 in Figure 12) to begin the sweep. Once the evaluation software completes the sweep, it automatically returns both a plot of the impedance vs. frequency and phase vs. frequency for the impedance under test (see Figure 12). The progress of the sweep is outlined with a progress bar, as shown in Figure 14.



Figure 14. Sweep Progress Bar (Blue)

- Click **Measure** in the **Internal Temperature** section of the evaluation board software front panel to take a reading from the on-board temperature sensor. This returns the 13-bit temperature of the device. See AD5933 data sheet for more information on the temperature sensor.
- Click **Download Impedance Data** to download the frequency sweep data (that is, frequency, impedance phase, real, imaginary, and magnitude data) from the DFT of the sweep (see 5 in Figure 12). The common dialog front panel is presented as shown in Figure 15. Choose a file name in a directory of choice and click **Save** (see Figure 15). This saves the sweep data to a comma separated variable file (.CSV) located in the chosen directory.

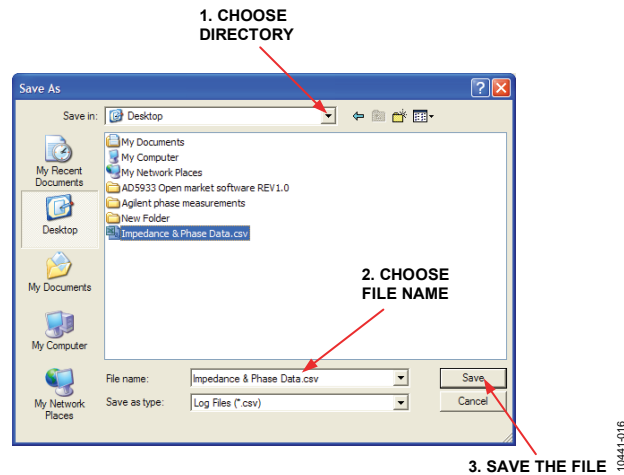

Figure 15. Saving the Sweep Data

The contents of this file can be accessed by using Notepad or Microsoft Excel to plot the data. Each file contains a single column of data. The format of the downloaded data is shown in Figure 16.

	A	B	C	D	E	F	G
1	Frequency	Impedance	Phase	Real	Imaginary	Magnitude	
2	30000	199980.7	-7.88E-02	-3726	8990	9731.556	
3	30002	200064.5	-7.52E-02	-3725	8986	9727.478	
4	30004	200029.8	-6.66E-02	-3727	8987	9729.167	
5	30006	200056.7	-6.98E-02	-3726	8986	9727.861	
6	30008	200067.8	-6.21E-02	-3727	8985	9727.32	
7	30010	199995.1	-5.80E-02	-3729	8988	9730.857	
8	30012	200037.7	-7.20E-02	-3726	8987	9728.784	

Figure 16. Opening the Sweep Data in Excel

Each data entry corresponds to a single measurement (frequency) point; therefore, if the value for the number of increments is programmed as 511 point, the array contains a single column of data with 512 data points, starting at the start frequency and ending at stop frequency value, which is determined by

$$\text{Start Frequency} + (\text{Number of Increments} \times \text{Delta Frequency})$$

The impedance profile and phase profile vs. frequency appears in the evaluation software front panel after the sweep has completed. Click the individual tabs to switch between **Absolute Impedance $|Z|$** and **Impedance Phase \angle** . Click **Absolute Impedance $|Z|$** to show how the impedance under analysis (Z_{UNKNOWN}) varies across the programmed frequency range. To view how the phase across the network under analysis varies, click **Impedance Phase \angle** , as shown in Figure 17.

Note that the phase measured by the [AD5933](#) takes into account the phase introduced through the entire signal path, that is, the phase introduced through the output amplifiers, receive current-to-voltage (I-V) amplifier, and the low-pass filter, along with the phase through the impedance (Z_{θ}) under analysis connected between VOUT and VIN (Pin 6 and Pin 5 of the [AD5933](#)). Calibrate out the phase of the system using a resistor before any subsequent impedance (Z_{θ}) phase measurement is calculated. Calibrate with a resistor in the evaluation software to calibrate the system phase correctly (refer to the Impedance Measurement Tips section for further details).

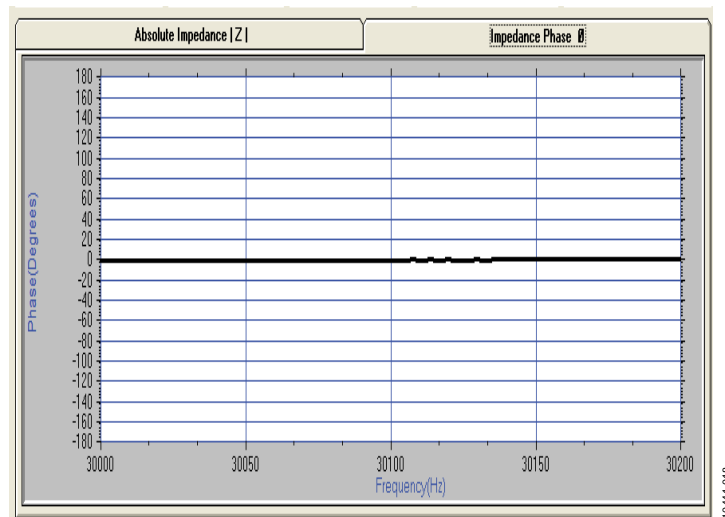

Figure 17. The Phase Tab on the [AD5933](#) Evaluation Software Front Panel, Phase of 200 k Ω Resistor (0°) Displayed

TWO INSTALLATION FREQUENTLY ASKED QUESTIONS

Q: How can I confirm that the hardware was correctly installed on the PC?

A: To confirm the hardware was correctly installed on the PC, use the following steps:

1. Right-click **My Computer** and left-click **Properties**.
2. Go to the **Hardware** tab, and click **Device Manager** (see Figure 18).

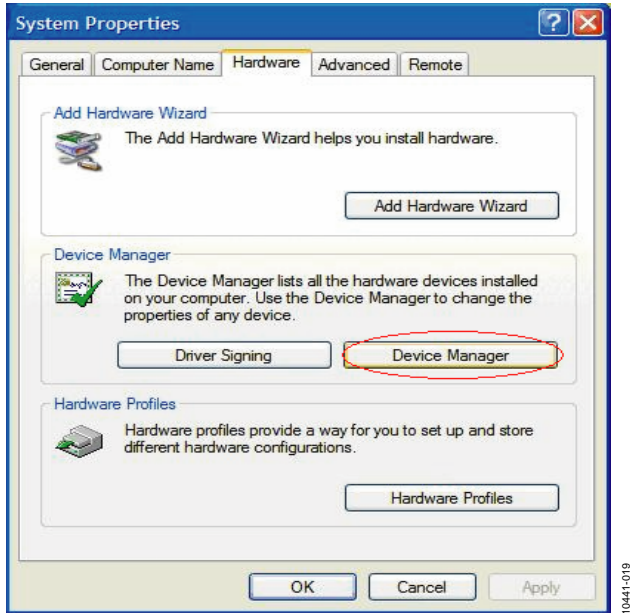

Figure 18. System Properties

3. Scroll to **Universal Serial Bus controllers** and expand the root directory (see Figure 19). When the **AD5933** hardware is correctly installed, each time the USB cable connecting the evaluation board to the computer is plugged in, the items within the **Universal Serial Bus controllers** are refreshed.

Figure 19 shows what to expect when the **AD5933** evaluation board is correctly installed and when the evaluation board and USB cable are connected correctly to the computer. The root directory is subsequently refreshed when the USB cable is unplugged from evaluation board, and the **AD5933** evaluation kit icon is removed from the main root.

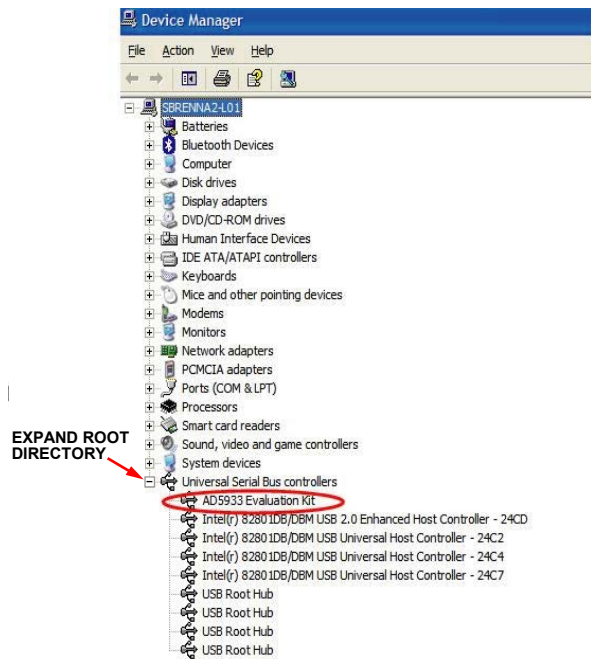

Figure 19. Correctly Installed Hardware

Q: During installation, when the board is plugged in for the first time, the message shown in Figure 20 appears. When I click **Finish**, the message shown in Figure 21 appears. What do I do next?



Figure 20. Error During the Hardware Installation

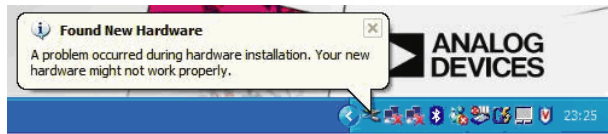

Figure 21. Found New Hardware Issue

A: If the evaluation software is installed correctly (install the software correctly prior to plugging in the board for the first time), this message simply indicates that the **AD5933** device drivers have not been installed to the correct registry and, therefore, could not be correctly located by the install wizard.

To reinstall the device drivers, use the following steps:

1. Right-click **My Computer**, and left-click **Properties**.
2. Go to the **Hardware** tab, select **Device Manager**, and expand **Other devices** (see Figure 22). The computer has not recognized the USB device, that is, the **AD5933** evaluation board.
3. Right-click **USB Device** and select **Uninstall Driver**.
4. Unplug the evaluation board and wait approximately 30 seconds before plugging it in again.
5. Proceed through the installation wizard a second time. The expanded root directory shown in Figure 19 is a correct installation. If the same error message is encountered the second time, uninstall the device driver, uninstall the software, and contact Analog Devices applications support at www.analog.com for further instructions regarding valid driver files.

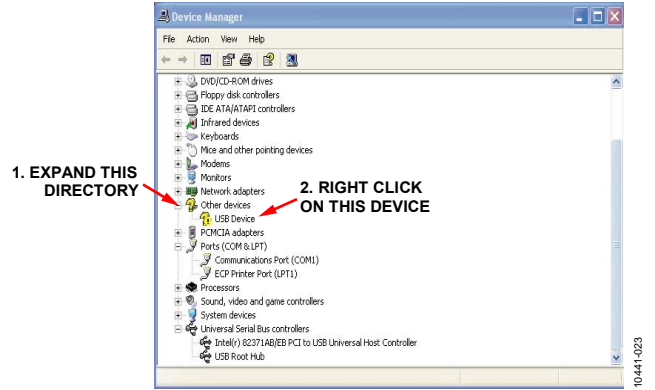

Figure 22. USB Device Not Recognized

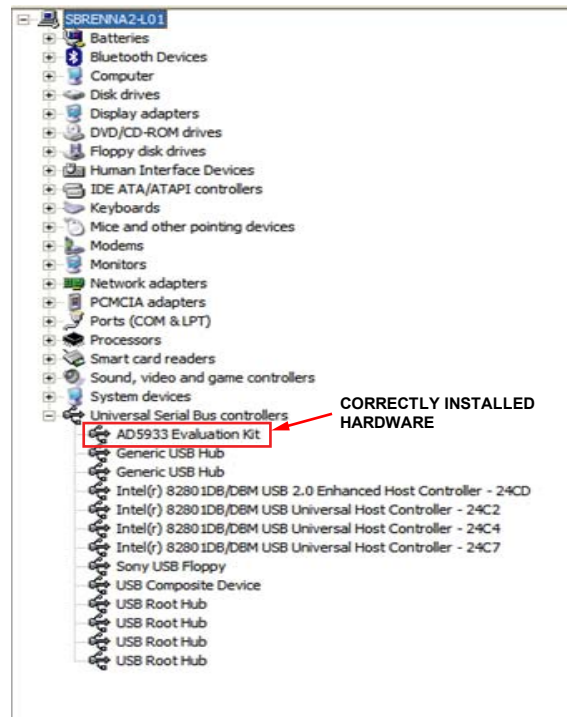

Figure 23. Correctly Installed Hardware

SOURCE CODE FOR IMPEDANCE SWEEP

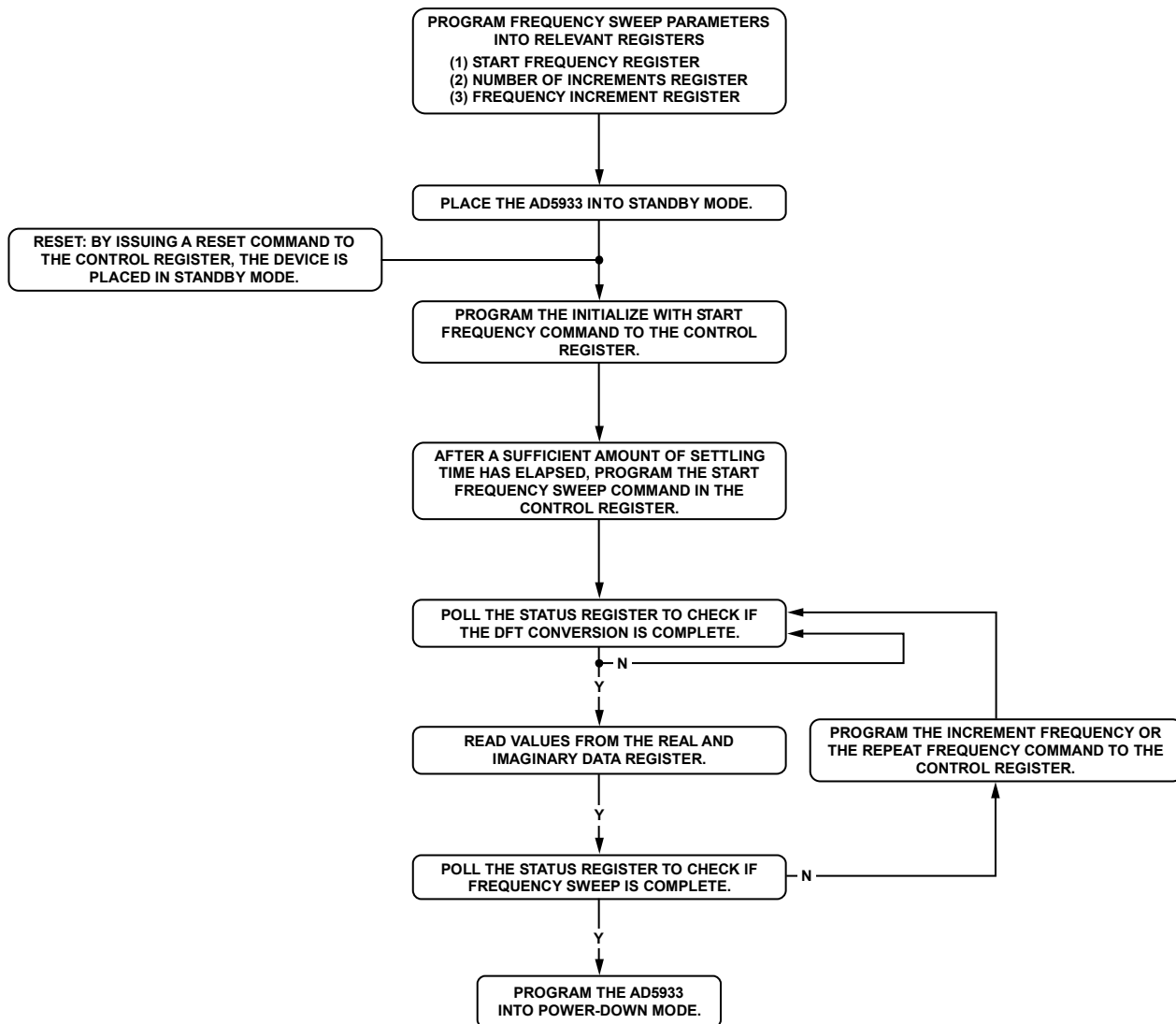

Figure 24. Sweep Flow Outline

1044-025

This section outlines the evaluation board code structure required to set up the [AD5933](#) frequency sweep. The sweep flow outline is shown in Figure 24. Each section of the flow diagram is explained with the help of the visual basic code extracts. The firmware code (c code), which is downloaded to the USB microcontroller connected to the [AD5933](#), implements the low level I²C signal control (that is, read and write vendor request).

The code extract, which is shown in the Evaluation Board Source Code Extract section, shows how to program a single frequency sweep starting at 30 kHz, with a frequency step of 10 Hz and with 150 points in the sweep. The code assumes that a 16 MHz clock signal is connected to Pin 8 (MCLK) of

the [AD5933](#). The impedance range under test is from 90 k Ω to 110 k Ω . The gain factor is calculated at the midpoint of the frequency sweep, that is, 30.750 kHz. The calibration is carried out with a 100 k Ω resistor connected between VOUT and VIN. The feedback resistor = 100 k Ω .

The first step in Figure 24 is to program the three sweep parameters necessary to define the frequency sweep (that is, the start frequency, number of increments, and frequency increments). Refer to the [AD5933](#) data sheet for more details.

EVALUATION BOARD SOURCE CODE EXTRACT

```

-----
'Code developed using visual basic® 6.
'Datatype   range
'Byte       0-255
'Double     -1.797e308 to - 4.94e-324 and 4.94e-324 to 1.7976e308
'Integer    -32,768 to 32767
'Long       -2,147,483,648 to 2,147,483,647
'Variant'...when storing numbers same range as double. When storing strings same range as string.
-----
Variable Declarations -----
Dim ReadbackStatusRegister As Long  'stores the contents of the status register.
Dim RealData As Double              'used to store the 16 bit 2s complement real data.
Dim RealDataUpper As Long           'used to store the upper byte of the real data.
Dim RealDataLower As Long           'used to store the lower byte of the real data.
Dim ImaginaryData As Double          'used to store the 16 bit 2s complement real data.
Dim ImaginaryDataLower As Long       'used to store the upper byte of the imaginary data.
Dim ImaginaryDataUpper As Long       'used to store the lower byte of the imaginary data.
Dim Magnitude As Double              'used to store the sqrt (real^2+imaginary^2).
Dim Impedance As Double              'used to store the calculated impedance.
Dim MaxMagnitude As Double           'used to store the max impedance for the y axis plot.
Dim MinMagnitude As Double           'used to store the min impedance for the y axis plot.
Dim sweep_phase As Double            'used to temporarily store the phase of each sweep point.
Dim Frequency As Double              'used to temporarily store the current sweep frequency.
Dim Increment As Long                'used as a temporary counter
Dim i As Integer                     'used as a temporary counter in (max/min) mag,phase loop
Dim xy As Variant                    'used in the stripx profile
Dim varray As Variant
Dim Gainfactor as double              'either a single mid point calibration or an array of calibration points
Dim TempStartFrequency As Double
Dim StartFrequencybyte0 As Long
Dim StartFrequencybyte2 As Long
Dim StartFrequencybyte1A As Long
Dim StartFrequencybyte1B As Long
Dim DDSRefClockFrequency As Double
Dim NumberIncrementsbyte0 As Long
Dim NumberIncrementsbyte1 As Long
Dim FrequencyIncrementbyt0 As Long
Dim FrequencyIncrementbyt1 As Long
Dim FrequencyIncrementbyt2 As Long
Dim SettlingTimebyte0 As Long
Dim SettlingTimebyte1 As Long
-----
I^2C read/write definitions-----
'used in the main sweep routine to read and write to AD5933.This is the vendor request routines in the
firmware

Private Sub WritetToPart(RegisterAddress As Long, RegisterData As Long)
PortWrite &HD, RegisterAddress, RegisterData
'parameters = device address register address register data
End Sub

Public Function PortWrite(DeviceAddress As Long, AddrPtr As Long, DataOut As Long) As Integer
PortWrite = VendorRequest(VRSMBus, DeviceAddress, CLng(256 * DataOut + AddrPtr), VRWRITE, 0, 0)
End Function

Public Function PortRead(DeviceAddress As Long, AddrPtr As Long) As Integer
PortRead = VendorRequest(VRSMBus, DeviceAddress, AddrPtr, VRREAD, 1, DataBuffer(0))
PortRead = DataBuffer(0)
End Function

-----
PHASE CONVERSION FUNCTION DEFINITION -----
'This function accepts the real and imaginary data(R, I) at each measurement sweep point and converts it to
a degree
-----
Public Function phase_sweep (ByVal img As Double, ByVal real As Double) As Double

Dim theta As Double
Dim pi As Double
pi = 3.141592654

If ((real > 0) And (img > 0)) Then
theta = Atn(img / real)          ' theta = arctan (imaginary part/real part)
phase2 = (theta * 180) / pi      'convert from radians to degrees

```

```

ElseIf ((real > 0) And (img < 0)) Then
    theta = Atn(img / real)                '4th quadrant theta = minus angle
    phase2 = ((theta * 180) / pi ) +360

ElseIf ((real < 0) And (img < 0)) Then
    theta = -pi + Atn(img / real)          '3rd quadrant theta img/real is positive
    phase2 = (theta * 180) / pi

ElseIf ((real < 0) And (img > 0)) Then
    theta = pi + Atn(img / real)           '2nd quadrant img/real is neg
    phase2 = (theta * 180) / pi

End If

End Function
'-----

Private Sub Sweep ()
' the main sweep routine

'This routine coordinates a frequency sweep using a mid point gain factor (see datasheet).
'The gain factor at the mid-point is determined from the real and imaginary contents returned at this mid
'point frequency and the calibration impedance.
'The bits of the status register are polled to determine when valid data is available and when the sweep is
'complete.
'-----
IndexArray = 0                'initialize counter variable.
Increment = NumberIncrements + 1 'number of increments in the sweep.
Frequency = StartFrequency     'the sweep starts from here.

'----- PROGRAM 30K Hz to the START FREQUENCY register -----
DDSRefClockFrequency = 16E6    'Assuming a 16M Hz clock connected to MCLK
StartFrequency = 30E3          'frequency sweep starts at 30K Hz

TempStartFrequency = (StartFrequency / (DDSRefClockFrequency / 4)) * 2^27 'dial up code for the DDS
TempStartFrequency = Int(TempStartFrequency) '30K Hz = 0F5C28 hex

StartFrequencybyte0 = 40      '40 DECIMAL = 28 HEX
StartFrequencybyte1 = 92      '92 DECIMAL = 5C HEX
StartFrequencybyte2 = 15      '15 DECIMAL = 0F HEX

'Write in data to Start frequency register
WritetToPart &H84, StartFrequencybyte0 '84 hex lsb
WritetToPart &H83, StartFrequencybyte1 '83 hex
WritetToPart &H82, StartFrequencybyte2 '82 hex
'----- PROGRAM the NUMBER OF INCREMENTS register -----
'The sweep is going to have 150 points 150 DECIMAL = 96 hex
'Write in data to Number Increments register
WritetToPart &H89, 96          'lsb
WritetToPart &H88, 00         'msb
'----- PROGRAM the FREQUENCY INCREMENT register -----
'The sweep is going to have a frequency increment of 10Hz between successive points in the sweep

DDSRefClockFrequency = 16E6    'Assuming a 16M Hz clock connected to MCLK
FrequencyIncrements = 10       'frequency increment of 10Hz

TempStartFrequency = (FrequencyIncrements / (DDSRefClockFrequency / 4)) * 2^27 'dial up code for the DDS
TempStartFrequency = Int(TempStartFrequency) '10 Hz = 335 decimal = 00014F hex

FrequencyIncrementbyt0 = 4F     '335 decimal = 14f hex
FrequencyIncrementbyt1 = 01
FrequencyIncrementbyt2 = 00

'Write in data to frequency increment register
WritetToPart &H87, FrequencyIncrementbyt0 '87 hex lsb
WritetToPart &H86, FrequencyIncrementbyt1 '86 hex
WritetToPart &H85, FrequencyIncrementbyt2 '85 hex msb

'----- PROGRAM the SETTling TIME CYCLES register -----
'The DDS is going to output 15 cycles of the output excitation voltage before the ADC will start sampling
'the response signal. The settling time cycle multiplier is set to x1

```

```
SettlingTimebyte0 = 0F '15 cycles (decimal) = 0F hex
SettlingTimebyte1 = 00 '00 = X1
```

```
WritetToPart &H8B, SettlingTimebyte0
WritetToPart &H8A, SettlingTimebyte1
```

```
'----- PLACE AD5933 IN STANDBYMODE -----
'Standby mode command = B0 hex
WritetToPart &H80, &HB0

'----- Program the system clock and output excitation range and PGA setting-----
'Enable external Oscillator
WritetToControlRegister2 &H81, &H8
'Set the output excitation range to be 2vp-p and the PGA setting to = x1
WritetToControlRegister2 &H80, &H1

'----- Initialize impedance under test with start frequency -----
'Initialize Sensor with Start Frequency
WritetToControlRegister &H80, &H10

msDelay 2 'this is a user determined delay dependent upon the network under analysis (2ms delay)

'----- Start the frequency sweep -----
'Start Frequency Sweep
WritetToControlRegister &H80, &H20

'Enter Frequency Sweep Loop

ReadbackStatusRegister = PortRead(&HD, &H8F)
ReadbackStatusRegister = ReadbackStatusRegister And &H4 ' mask off bit D2 (i.e. is the sweep complete)

Do While ((ReadbackStatusRegister <> 4) And (Increment <> 0))
'check to see if current sweep point complete

ReadbackStatusRegister = PortRead(&HD, &H8F)
ReadbackStatusRegister = ReadbackStatusRegister And &H2
'mask off bit D1 (valid real and imaginary data available)
'-----
If (ReadbackStatusRegister = 2) Then
' this sweep point has returned valid data so we can proceed with sweep
Else
Do
'if valid data has not been returned then we need to pole stat reg until such time as valid data
'has been returned
'i.e. if point is not complete then Repeat sweep point and pole status reg until valid data
returned
WritetToControlRegister &H80, &H40 'repeat sweep point
Do
ReadbackStatusRegister = PortRead(&HD, &H8F)
ReadbackStatusRegister = ReadbackStatusRegister And &H2
' mask off bit D1- Wait until dft complete
Loop While (ReadbackStatusRegister <> 2)

Loop Until (ReadbackStatusRegister = 2)
End If
'-----

RealDataUpper = PortRead(&HD, &H94)
RealDataLower = PortRead(&HD, &H95)
RealData = RealDataLower + (RealDataUpper * 256)
'The Real data is stored in a 16 bit 2's complement format.
'In order to use this data it must be converted from 2's complement to decimal format
If RealData <= &H7FFF Then ' h7fff 32767
' Positive
Else
' Negative
RealData = RealData And &H7FFF
RealData = RealData - 65536
End If
ImagineryDataUpper = PortRead(&HD, &H96)
```

```

ImaginaryDataLower = PortRead(&HD, &H97)
ImaginaryData = ImaginaryDataLower + (ImaginaryDataUpper * 256)
'The imaginary data is stored in a 16 bit 2's complement format.
'In order to use this data it must be converted from 2's complement to decimal format
If ImaginaryData <= &H7FFF Then
' Positive Data.
Else
' Negative
' ImaginaryData = ImaginaryData And &H7FFF
ImaginaryData = ImaginaryData - 65536
End If

'-----Calculate the Impedance and Phase of the data at this frequency sweep point -----
Magnitude = ((RealData ^ 2) + (ImaginaryData ^ 2)) ^ 0.5
'the next section calculates the phase of the dft real and imaginary components
'phase_sweep calculates the phase of the sweep data.
sweep_phase = (phase_sweep(ImaginaryData, RealData) - calibration_phase_mid_point)
GainFactor = xx 'this is determined at calibration. See gain factor section and Datasheet.
Impedance = 1 / (Magnitude * GainFactor)

' Write Data to each global array.
MagnitudeArray(IndexArray) = Impedance
PhaseArray(IndexArray) = sweep_phase
ImaginaryDataArray(IndexArray) = ImaginaryData
code(IndexArray) = Magnitude
RealDataArray(IndexArray) = RealData
Increment = Increment - 1 ' increment was set to number of increments of sweep at the start
FrequencyPoints(IndexArray) = Frequency
Frequency = Frequency + FrequencyIncrements ' holds the current value of the sweep freq
IndexArray = IndexArray + 1

----- Check to see if sweep complete -----
ReadbackStatusRegister = PortRead (&HD, &H8F)
ReadbackStatusRegister = ReadbackStatusRegister And &H4 ' mask off bit D2

'Increment to next frequency point Frequency
WritetToControlRegister &H80, &H30
Loop

'----- END OF SWEEP: Place device into POWERDOWN mode-----
'Enter Powerdown Mode,Set Bits D15,D13 in Control Register.
WritetToPart &H80, &HA0

END SUB
'-----

'The programmed sweep is now complete and the impedance and phase data is available to read in the two
'arrays MagnitudeArray() = Impedance and PhaseArray() = phase.

sweepErrorMsg:
MsgBox "Error completing sweep check values"
End Sub

'The programmed sweep is now complete and the impedance and phase data is available to read in the two
'arrays MagnitudeArray() = Impedance and PhaseArray() = phase.

```

GAIN FACTOR CALCULATION

The code shown in the Evaluation Board Source Code Extract section for the impedance sweep is based on a single point gain factor calculation. This calculation is carried out once system calibration is at the midpoint sweep frequency and with a known impedance connected between VOUT and VIN. The gain factor is calculated by exciting the calibration impedance with a 2 V p-p sinusoid with a frequency of 30.750 kHz. The PGA setting is $\times 1$. The calibration is carried out with a 100 k Ω resistor connected between VOUT and VIN. The feedback resistor is 100 k Ω . The magnitude of the real and imaginary component at the calibration frequency is given by the formula

$$\text{Magnitude} = \sqrt{R^2 + I^2}$$

where:

R is the real component.

I is the imaginary component of the calibration code.

Example Code for Temperature Measurement

```
Private Sub MeasureTemperature()
' The Digital temperature Result is stored over two registers as a 14 bit twos complement number.
' 92H <D15-D8> and 93H<D7 to D0>.
Dim TemperatureUpper As Long.
Dim TemperatureLower As Long
'Write xH90 to the control register to take temperature reading.
WritetToPart &H80, &H90
msDelay 5 'nominal delay
ReadbackStatusRegister = PortRead(&HD, &H8F)
ReadbackStatusRegister = ReadbackStatusRegister And &H1
'if a valid temperature conversion is complete, ignore this.
If ReadbackStatusRegister <> 1 Then
    'loop to wait for temperature measurement to complete.
    Do
        ReadbackStatusRegister = PortRead(&HD, &H8F)
        ReadbackStatusRegister = ReadbackStatusRegister And &H1
    Loop Until (ReadbackStatusRegister = 1)
    Form1.Label10.Caption = "Current Device Temperature"
    MsgBox "Device Temperature Measurement Complete"
End If

' The Digital temperature Result is stored over two registers as a 14 bit twos complement number.
' 92H <D15-D8> and 93H<D7 to D0>.
TemperatureUpper = PortRead(&HD, &H92)
TemperatureLower = PortRead(&HD, &H93)
Temperature = TemperatureLower + (TemperatureUpper * 256)

If Temperature <= &H1FFF Then ' msb =0.
' Positive Temperature.
Label8.Caption = (Temperature / 32#)
Else
' Negative Temperature.
```

The gain factor is then given by

$$\text{GainFactor} = \left(\frac{\text{Admittance}}{\text{Code}} \right) = \frac{\left(\frac{1}{\text{Impedance}} \right)}{\text{Magnitude}} = \frac{\left(\frac{1}{100 \text{ k}\Omega} \right)}{\text{Magnitude}}$$

Refer to the [AD5933](#) data sheet for more details.

TEMPERATURE MEASUREMENT

Refer to the [AD5933](#) data sheet for details on the temperature sensor. The temperature sensor data is stored in a 14-bit twos complement format. The conversion formula is given in the [AD5933](#) data sheet.

```
Label8.Caption = (Temperature - 16384) / 32#
End If
're-assign variables used.
TemperatureUpper = 0
TemperatureLower = 0
Temperature = 0
End Sub
```

IMPEDANCE MEASUREMENT TIPS

This section outlines some of the workarounds for using the [AD5933](#) to measure the impedance profiles under certain conditions.

Calibrating the AD5933

When calculating the calibration term (that is, gain factor, see the [AD5933](#) data sheet for further details), it is important that the receive stage operates in its linear region. This requires careful selection of the system gain settings. The system gain settings include the following:

- Output excitation voltage range
- Current-to-voltage gain setting resistor
- PGA gain

The gain through the system shown in Figure 25 is given by

$$\text{Output Excitation Voltage Range} \times \frac{\text{Gain Setting Resistor}}{Z_{\text{UNKNOWN}}} \times \text{PGA Gain}$$

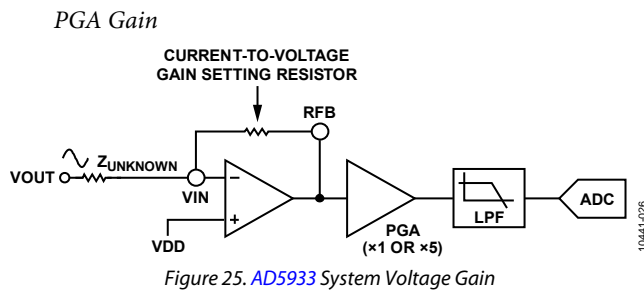

Figure 25. [AD5933](#) System Voltage Gain

For example, assume the following system calibration settings:

- VDD = 3.3 V
- Gain setting resistor = 200 kΩ
- Z_UNKNOWN = 200 kΩ
- PGA setting = ×1
- Range 1 = 2 V p-p

The peak-to-peak voltage presented to the ADC input is 2 V p-p. However, if a programmable gain amplifier setting gain of ×5 is chosen, the voltage saturates the ADC, and the calculated calibration term (that is, the gain factor) is inaccurate due to the saturation of the ADC.

Calculate the gain factor when the largest response signal is presented to the ADC while ensuring that the signal is always maintained within the linear range of the ADC over the impedance range of interest (the reference range of the ADC is the AVDD supply).

Configure the system gain settings (see Figure 25), that is, the output excitation voltage range (Range 1, Range 2, Range 3, or Range 4), the I-V amplifier gain setting resistor based on the unknown impedance range of interest, and the programmable gain amplifier setting (either ×1 or ×5) that proceeds the ADC.

Choose a calibration impedance that is midvalue between the limits of the unknown impedance; therefore, the user must know the impedance limits to correctly calibrate the system. Then choose an equal value I-V gain setting resistor to the calibration impedance. This results in a unity gain condition about the receive side of the I-V amplifier.

For example, assume the following:

- Unknown test impedance limits are 180 kΩ ≤ Z_UNKNOWN ≤ 220 kΩ
- Frequency range of interest is 30 kHz to 32 kHz

The following are the system calibration gain settings:

- VDD = 3.3 V
- Gain setting resistor (R_FB) = 200 kΩ
- Z_CALIBRATION = 200 kΩ
- PGA setting = ×1
- Calibration frequency = 31 kHz (midpoint frequency)

The gain factor calculated at the midpoint frequency of 31 kHz can be used to calculate any impedance in the 180 kΩ to 220 Ω region. Impedance results degrade if the unknown impedance span is large or if the frequency sweep is large. If any of the calibration system gain settings change, recalibrate the [AD5933](#) and recalculate the gain factor (see [AD5933](#) data sheet for further details).

Measuring Lower Excitation Frequencies

The AD5933 has a flexible internal DDS core and a digital-to-analog converter (DAC) that together generate the excitation signal used to measure the impedance ($Z_{UNKNOWN}$). The DDS core has a 27-bit phase accumulator that allows subhertz (0.1 Hz) frequency resolution. The output of the phase accumulator is connected to the input of a read-only memory (ROM). The digital output of the phase accumulator is used to address individual memory locations in the ROM. The digital contents of the ROM represent amplitude samples of a single cycle of a sinusoidal excitation waveform. The contents of each address within the ROM look-up table are in turn passed to the input of a DAC that produces the analog excitation waveform made available at the VOUT pin. The DDS core (that is, the phase accumulator and the ROM look-up) and the DAC are all referenced from a single system clock. The function of the phase accumulator is simply to act as a system clock divider.

The system clock for the AD5933 DDS engine can be provided in one of two ways.

- The user can provide a highly accurate and stable clock (crystal oscillator) at the external clock pin, MCLK (Pin 8).
- Alternatively, the AD5933 provides an internal clock oscillator with a typical frequency of 16.776 MHz.

The user can select the preferred system clock by programming Bit D3 in the control register (Address 0x81, see the AD5933 data sheet).

The internal ADC also uses the system clock to digitize the response signal. The ADC requires 16 clock periods to perform a single conversion. Therefore, with a maximum system clock frequency of 16.776 MHz, the ADC can sample the response signal with a frequency of 1.0485 MHz, that is, a throughput rate of ≈ 1.04 MSPS. The ADC converts 1024 samples and passes the digital results to the MAC core for processing. The AD5933 MAC core performs a 1024 point DFT to determine the peak of the response signal at the ADC input. The DFT offers many advantages over conventional peak detection mechanisms, including excellent dc rejection, an averaging of errors, and phase information.

The throughput rate of the AD5933 ADC scales with the system clock, that is, lower ADC throughput rates, and therefore sampling frequencies can be achieved by lowering the system clock.

The conventional DFT assumes a sequence of periodic input data samples to determine the spectral content of the original continuous signal. In the AD5933, these samples obviously come from the 12-bit ADC for a user-defined range of signal frequencies.

The conventional DFT correlates the input signal against a series of test phasor frequencies to determine the fundamental signal frequency and its harmonics. The frequency of the test phasor is at integer multiples of a fundamental frequency given by the following formula:

$$Test\ Phasor\ Frequency = (f_s/N)$$

where:

f_s is the sampling frequency of the ADC.

N is the number of samples taken equals 1024.

The correlation is performed for each frequency integer fundamental. If the resulting correlation of the test phasor with the input sample set is nonzero, there is signal energy at this frequency. If no energy is found in a bin, there can be no energy at that test frequency.

The DFT implemented by the AD5933 is called a single point DFT; this means that the analysis or correlation frequency in the MAC core is always at the same frequency as the current output excitation frequency. Therefore, when the system clock for the AD5933 is 16.776 MHz, the sample rate of the ADC is 1.04 MHz. The DSP core requires 1024 samples to perform the single point DFT. Therefore, the resolution of the DFT is 1.04 MHz/1024 points ≈ 1 kHz. This calculation is based on a system clock frequency of 16 MHz being applied at MCLK. If the AD5933 tries to examine excitation frequencies below ≈ 1 kHz, the errors introduced by the spectral leakage become significant and result in erroneous impedance readings.

If the input signal does not have an exact integer number of cycles over the 1024-point sample interval, as shown in Figure 26, there will not be a smooth transition from the end of one period to the next, as shown in Figure 27. The leakage is a result of the discontinuities introduced by the DFT assuming a periodic input signal like that shown in Figure 27.

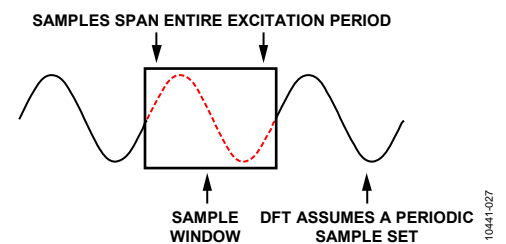

Figure 26. Sample Set Spanning the Entire Excitation Period

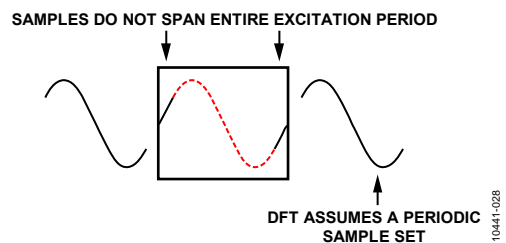

Figure 27. Sample Set Not Spanning the Entire Excitation Period

For the [AD5933](#) to analyze the impedance ($Z_{UNKNOWN}$) at frequencies lower than ≈ 1 kHz, it is necessary to scale the system clock such that the sample rate of the ADC is lowered and cause the 1024 samples required for the single point DFT to cover an integer number of periods of the current excitation frequency.

To analyze frequencies between the 1 kHz to 10 kHz range using the [AD5933](#) and a 16 MHz crystal, scale the system clock by using an external clock divider. This reduces the sampling frequency of the ADC to a value less than 1 MHz ($f_{SAMPLING} = MCLK/16$); however, the 1024 sample set now covers the response signal under analysis. When scaling the system clock, the maximum bandwidth of the sweep must be reduced.

To help analyze lower clock frequencies, scale the system clock connected to the [AD5933](#). This scaling establishes a lower impedance limit (see Table 2); however, the upper excitation frequency is now limited.

Table 2. Experimental Lower Frequency Limits vs. MCLK

AD5933 Lower Frequency ¹	Clock Frequency Applied to MCLK Pin ²
100 kHz to 5 kHz	16 MHz
5 kHz to 1 kHz	4 MHz
5 kHz to 300 Hz	2 MHz
300 Hz to 200 Hz	1 MHz
200 Hz to 100 Hz	250 kHz
100 Hz to 30 Hz	100 kHz
30 Hz to 20 Hz	50 kHz
20 Hz to 10 Hz	25 kHz

¹ Lower frequency sweep limit established by applying the divided clock signal to the MCLK pin of the [AD5933](#) and by calibrating and remeasuring a nominal impedance $Z_{CALIBRATION}$, for example, a 200 k Ω resistor over a 500 Hz linear sweep from the programmed start frequency (I-V gain resistor setting = $Z_{CALIBRATION}$, for example, 200 k Ω , PGA = X1, Δ Frequency = 5 Hz, and number of points = 100). The lower frequency limit is established as the frequency at which the DFT and, therefore, the impedance vs. the frequency results begin to degrade and deviate from the expected value of the measured impedance $Z_{CALIBRATION}$, for example, 200 k Ω .

² TTL clock levels applied to MCLK pin, $V_{IH} = 2$ V, and $V_{IL} = 0.8$ V.

As an example, if a scaled clock frequency of 4 MHz must be applied to the external clock pin of the [AD5933](#) to correctly analyze a 3 kHz signal that has already been established. The applied system clock (external or internal oscillator) is divided by a factor of 4 before being routed as the reference clock to the DDS. The system clock is directly connected to the ADC without any divide so that the ADC sampling clock is running at 4 times the speed of the DDS core. Therefore, with a system clock of 4 MHz, the DDS reference clock is now $1/4 \times 4$ MHz = 1 MHz, and the ADC clock is 4 MHz. The [AD5933](#) DDS has a 27-bit phase accumulator; however, the top three most significant bits (MSBs) are internally connected to logic zero. Therefore, with the top three MSBs set to zero, the maximum DDS output frequency is now reduced by a further factor of $1/8$ th. Therefore, the maximum output frequency is now $1/32 \times 1$ MHz = 31.25 kHz.

It is possible to accurately measure the 3 kHz signal using a lower system clock of 4 MHz; however, the two main trade-offs are that it takes the [AD5933](#) longer to return the impedance results due to the slower ADC conversion clock speed and that the upper excitation limit is now restricted to 31.25 kHz.

Measuring Higher Excitation Frequencies

The [AD5933](#) is specified to a typical system accuracy of 0.5% (assuming the [AD5933](#) system is calibrated correctly for the impedance range under test) within the frequency range of 1 kHz to 100 kHz. The lower frequency limit is determined by the value of the system clock frequency connected to the external clock pin (MCLK) of the [AD5933](#). The lower limit can be reduced by scaling the system clock (see the Measuring Lower Excitation Frequencies section). The upper frequency limit of the system is due to the finite bandwidth of the internal amplifiers coupled with the effects of the low-pass filter pole locations (for example, 200 kHz and 300 kHz), which are used to roll-off any noise signals from corrupting the DFT output on the receive side of the [AD5933](#). Therefore, the [AD5933](#) has a finite frequency response similar to that shown in Figure 28.

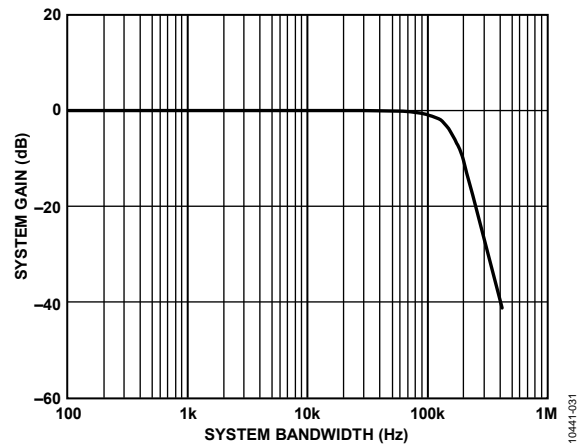

Figure 28. Typical [AD5933](#) System Bandwidth

Using the [AD5933](#) to analyze frequencies past 100 kHz introduces errors in impedance profile if the sweep span is large, due to the effect of the increased roll-off in the finite frequency response of the system past 100 kHz. However, if the user is sweeping in frequency above 100 kHz, it is important to ensure that the sweep range is as small as possible, for example, 120 kHz to 122 kHz. The impedance error from the calibration frequency is approximately linear over a small frequency range. The user can remove the linear error introduced by carrying out an endpoint/multipoint calibration (see the Two Point Calibration section of the [AD5933](#) data sheet for additional details on endpoint calibration).

Measuring the Phase Across an Impedance

The [AD5933](#) returns a complex output code made up of a separate real and imaginary component. The real component is stored at Register 0x94 and Register 0x95, and an imaginary component is stored at Register 0x96 and Register 0x97 after each sweep measurement. These correspond to the real and imaginary components of the DFT and not the resistive and reactive components of the impedance under test.

For example, it is a common misconception that when analyzing a series RC circuit that the real value stored in Register 0x94 and Register 0x95 and the imaginary value stored at Register 0x96 and Register 0x97 corresponds to the resistance and capacitive reactance, respectfully. However, this is incorrect; the magnitude of the impedance ($|Z|$) can be calculated by calculating the magnitude of the real and imaginary components of the DFT given by

$$\text{Magnitude} = \sqrt{R^2 + I^2}$$

After each measurement, multiply it by the calibration term (see gain factor calculation in [AD5933](#) data sheet) and invert the product. The magnitude of the impedance is therefore given by

$$\text{Impedance} = \frac{1}{\text{Gain Factor} \times \text{Magnitude}}$$

where the *Gain Factor* is given by

$$\text{Gain Factor} = \left(\frac{\text{Admittance}}{\text{Code}} \right) = \left(\frac{1}{\text{Impedance}} \right)$$

Before any valid measurement can take place, the [AD5933](#) system must be calibrated for a known impedance range to determine the gain factor. Therefore, the impedance limits of the complex impedance (Z_{UNKNOWN}) for the sweep frequency range of interest must be known. Place known impedance between the input/output of the [AD5933](#) and measure the resulting magnitude of the code to determine what the gain factor is. The [AD5933](#) system gain settings must be chosen to place the excitation signal in the linear region of the on-board ADC (refer to the [AD5933](#) data sheet for further details).

Because the [AD5933](#) returns a complex output code made up of a real and an imaginary component, the phase of the response signal through the [AD5933](#) signal path can be calculated. The phase is given by $\text{Phase (rads)} = \tan^{-1}(I/R)$.

The phase measured by the previous formula accounts for the phase shift introduced to the DDS output signal as it passes through the internal amplifiers on the transmit and receive side of the [AD5933](#) along with the low-pass filter and the impedance connected between the VOUT and VIN pins of the [AD5933](#).

The [AD5933](#) parameters of interest are the magnitude of the impedance ($|Z_{\text{UNKNOWN}}|$) and the impedance phase ($Z\emptyset$). The measurement of $Z\emptyset$ is a two-step process. The first step involves calculating the [AD5933](#) system phase. The [AD5933](#) system phase can be calculated by placing a resistor across the VOUT and VIN pins of the [AD5933](#) and calculating the phase (using the previous formula) after each measurement point in the sweep. By placing a resistor across the VOUT and VIN pins, there is no additional phase lead or lag introduced to the [AD5933](#) signal path, and the resulting phase is due entirely to the internal poles of the [AD5933](#), that is, the system phase.

Once the system phase has been calibrated using a resistor, the phase of any unknown impedance can be calculated by inserting the unknown impedance between the VIN and VOUT terminals of the [AD5933](#) and by recalculating the new phase (including the phase due to the impedance) using the previous formula. The phase of the unknown impedance ($Z\emptyset$) is given by

$$Z\emptyset = (\Phi_{\text{unknown}} - \nabla_{\text{system}})$$

where:

∇_{system} is the phase of the system with a calibration resistor connected between VIN and VOUT.

Φ_{unknown} is the phase of the system with the unknown impedance connected between VIN and VOUT.

$Z\emptyset$ is the phase due to the impedance, that is, the impedance phase.

Note that it is possible both to calculate the gain factor and to calibrate the system phase using the same real and imaginary component values when a resistor is connected between the VOUT and VIN pins of the [AD5933](#).

For example, measuring the impedance phase ($Z\emptyset$) of a capacitor.

The excitation signal current leads the excitation signal voltage across a capacitor by -90° ; therefore, before any measurement is taken, expect to see an approximate -90° phase difference between the system phase responses measured with a resistor and the system phase responses measured with capacitive impedance.

As previously outlined, to determine the phase angle of capacitive impedance ($Z\emptyset$), the system phase response (∇_{system}) must be determined and subtracted from the phase calculated with the capacitor connected between VOUT and VIN (Φ_{unknown}).

Figure 29 shows the AD5933 system phase response calculated using a 220 kΩ calibration resistor ($R_{FB} = 220 \text{ k}\Omega$, $PGA = \times 1$) and the repeated phase measurement with a 10 pF capacitive impedance.

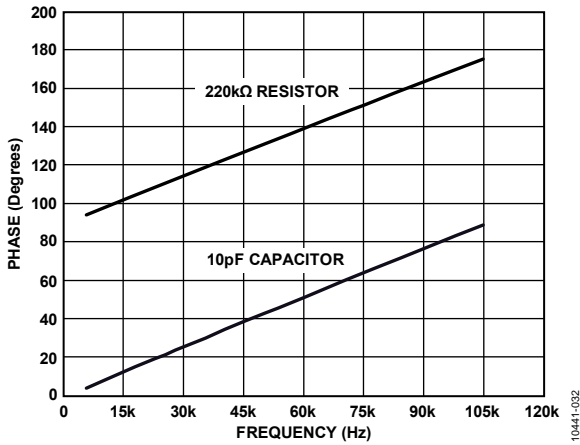

Figure 29. System Phase Response vs. Capacitive Phase

The phase difference (that is, $Z\theta$) between the phase response of a capacitor and the system phase response using a resistor is the impedance phase of the capacitor ($Z\theta$) and is shown in Figure 30.

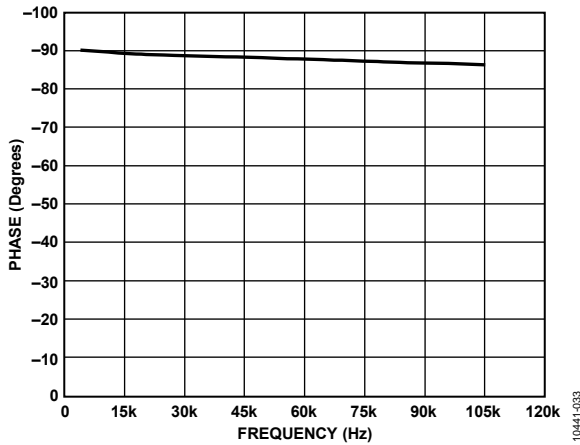

Figure 30. Phase Response of a Capacitor

Note that the phase formula used to plot Figure 29 uses the arctangent function that returns a phase angle in radians and, therefore, it is necessary to convert from radians to degrees.

In addition, take care when using the arctangent formula when using the real and imaginary values to interpret the phase at each measurement point. The arctangent function returns the correct standard phase angle only when the sign of the real and imaginary values are positive, that is, when the coordinates lie in the first quadrant. The standard angle is taken counter clockwise from the positive real x-axis. If the sign of the real component is positive and the sign of the imaginary component is negative, that is, the data lies in the second quadrant, the arctangent formula returns a negative angle, and it is necessary to add a further 180° to calculate the correct standard angle. Likewise, when the real and imaginary components are both negative, that is, when the coordinates lie in the third quadrant, the arctangent formula returns a positive angle, and it is necessary to add 180° to the angle to return the correct standard phase. Finally, when the real component is positive and the imaginary component is negative, that is, the data lies in the fourth quadrant, the arctangent formula returns a negative angle, and it is necessary to add 360° to the angle to calculate the correct phase angle.

Therefore, the correct standard phase angle is dependent on the sign of the real and imaginary component and is summarized in Table 3.

Table 3. Phase Angle

Real	Imaginary	Quadrant	Phase Angle (Degrees)
Positive	Positive	First	$\text{Tan}^{-1}(I/R) \times \frac{180}{\pi}$
Positive	Negative	Second	$180 + \left(\text{Tan}^{-1}(I/R) \times \frac{180}{\pi} \right)$
Negative	Negative	Third	$180 + \left(\text{Tan}^{-1}(I/R) \times \frac{180}{\pi} \right)$
Positive	Negative	Fourth	$360 + \left(\text{Tan}^{-1}(I/R) \times \frac{180}{\pi} \right)$

Once the magnitude of the impedance ($|Z|$) and the impedance phase angle ($Z\theta$, in radians) are correctly calculated, it is possible to determine the magnitude of the real (resistive) and imaginary (reactive) components of the impedance ($Z_{UNKNOWN}$) by the vector projection of the impedance magnitude onto the real and imaginary impedance axis using the following formulas:

The real component is given by

$$|Z_{REAL}| = |Z| \times \cos(Z\theta)$$

The imaginary component is given by

$$|Z_{IMAG}| = |Z| \times \sin(Z\theta)$$

EVALUATION BOARD SCHEMATICS AND ARTWORK

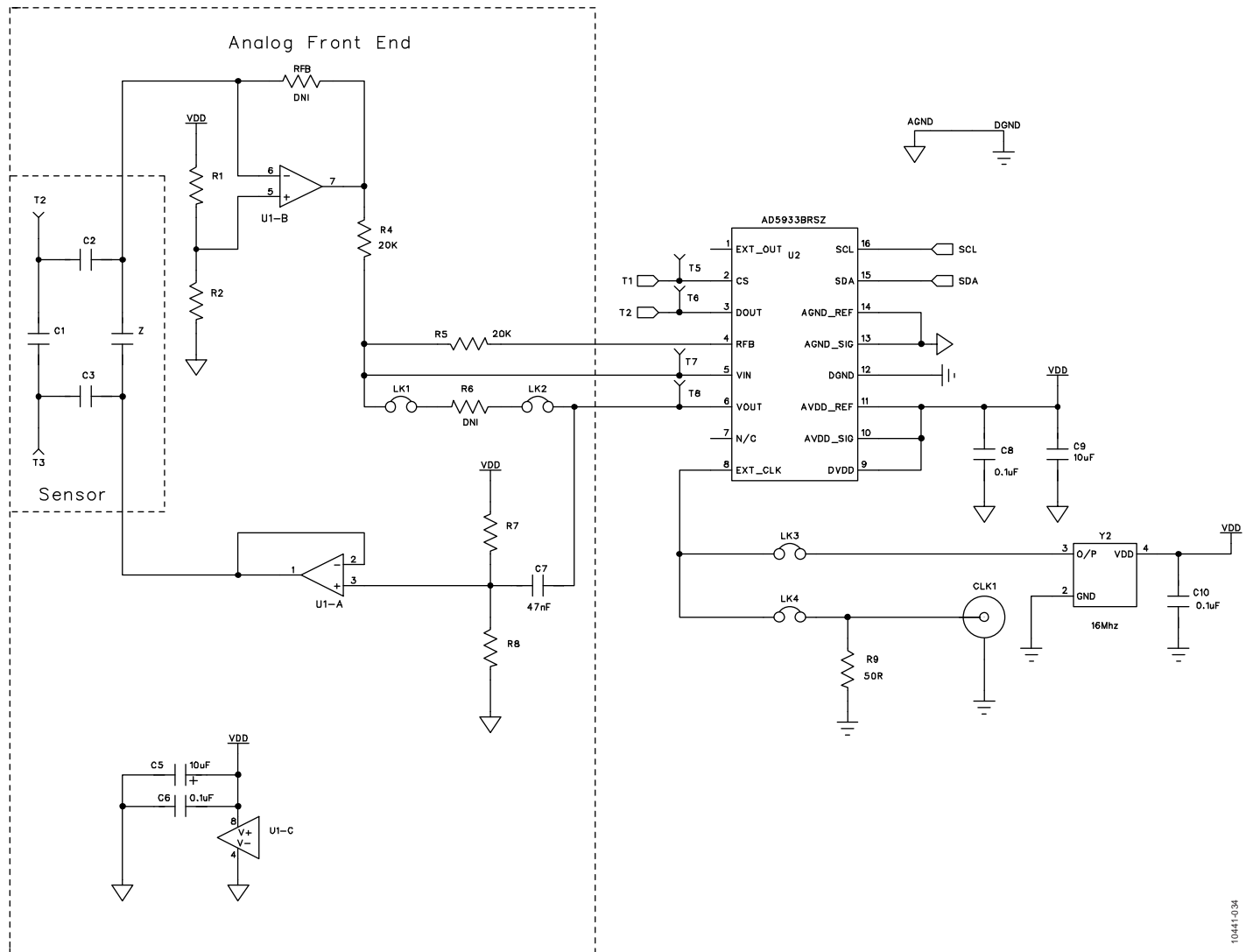

Figure 31. EVAL-AD5933EBZ USB Schematic

10441-034

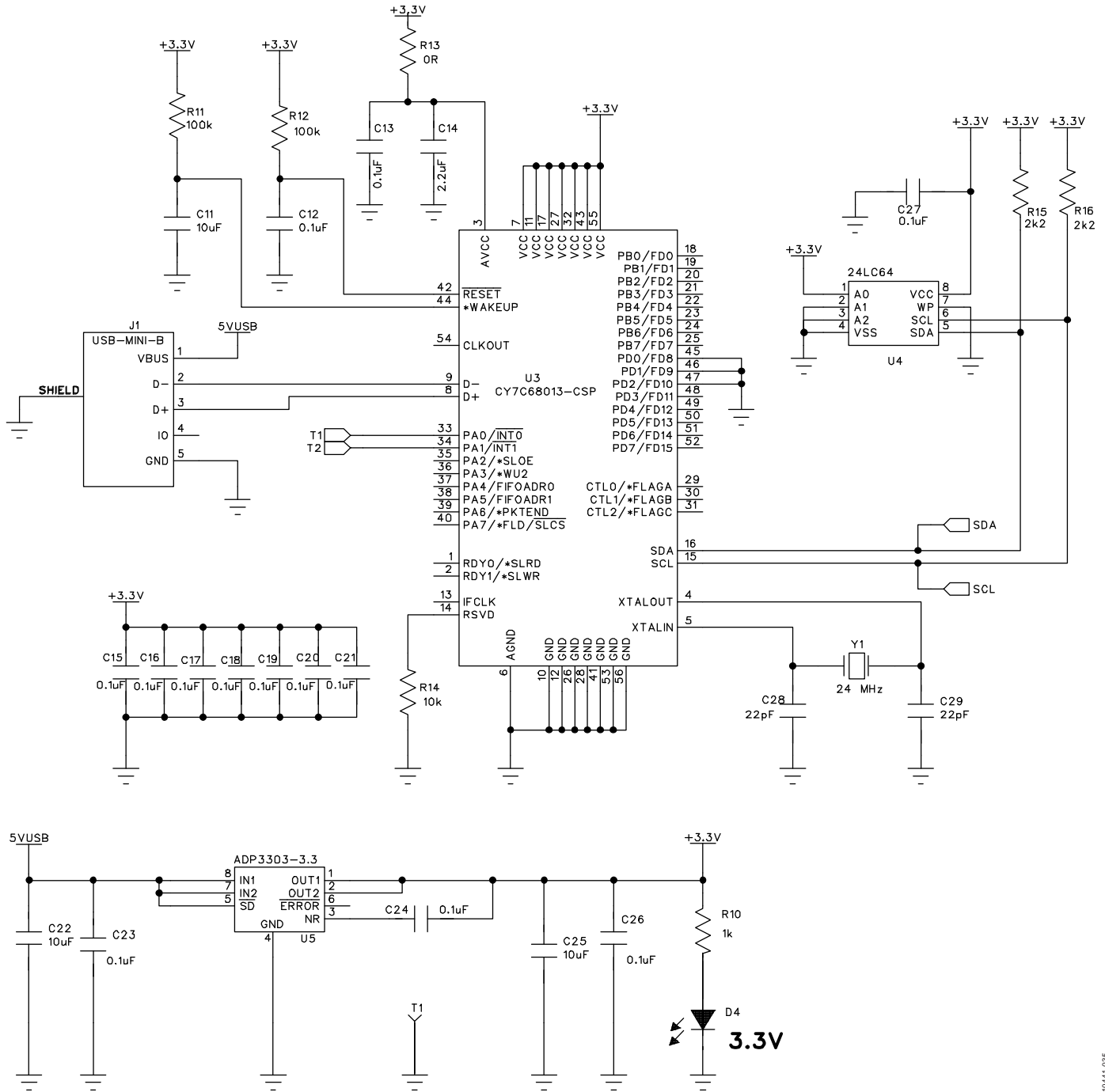

Figure 32. EVAL-AD5933EBZ Schematic

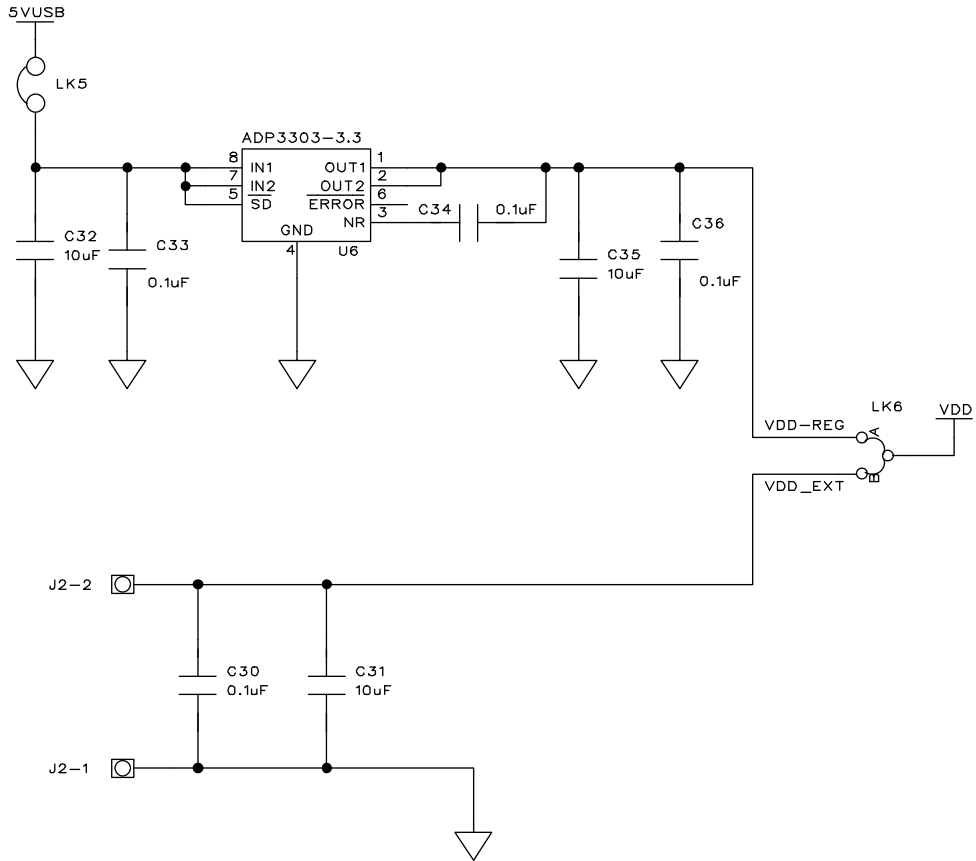

Figure 33. Linear Regulator on the EVAL-AD5933EB Evaluation Board

10441-036

ORDERING INFORMATION

BILL OF MATERIALS

Table 4.

Name	Part Description	Manufacturer	Part Number
C1 to C3 ¹	Capacitor, MR04, place holder	Not applicable	Not applicable
Z ¹	Capacitor, MR04, place holder, insert 2-wire wrap pins	Analog Devices issue	73017015
C5	10 µF tantalum capacitor, 10 V	AVX Corporation	TAJB106K016R
C7	47 nF capacitor, 50 V, through hole, 10%, R1/8 W	Multicomp	MCRR50473X7RK0050
C9, C11, C22, C25, C31, C32, C25	10 µF ceramic capacitor, X5R, 0805	Yageo Corporation	CC0805KKX5R6BB106
C14	2.2 µF ceramic capacitor, 6.3 V, X5R, 0603, SMD	Yageo Corporation	CC0603KRX5R5BB225
C6, C8, C10, C12, C13, C15 to C21, C23, C24, C26, C27, C30, C33, C34, C36	0.1 µF ceramic capacitor, 50 V, X7R, 10%, 0603, SMD	AVX Corporation	06035C104KAT2A
C28, C29	22 pF ceramic capacitor, 50 V, 5%, 0603, NPO, SMD	Yageo Corporation	CC0603JRNPO9BN220
CLK1	SMB socket	Tyco Electronics Corporation	1-1337482-0
D4	Green LED, 0805	Avago Technologies	HSMG-C170
GL1	Copper short ground link	Not applicable	Not applicable
J1	USB Mini-B connector	Molex	56579-0576
J2	2-pin terminal block (5 mm pitch), CON\POWER	Camden Electronics	CTB5000/2
LK1 to LK6	Jumper block, 2 pins, 0.1" spacing, SIP-2P	Harwin	M20-9990246
R1, R2, R7 to R8	49.9 kΩ, SMD resistor, 1%, 0603	Multicomp	MC 0.063W 0603 1% 49K9
CAL ¹	Place holder, insert 2-wire wrap pins, R1/8 W	Analog Devices issue	73017015
R4	20 kΩ, SMD resistor (0.1%), 0603	Panasonic	ERA3AEB203V
R5	20 kΩ, SMD resistor (0.1%), 0603	Multicomp	MC 0.063W 0603 1% 20K
R6 ¹	Through hole resistor, 1/8 W	Not applicable	Not applicable
R10	1 kΩ, 0805, SMD resistor	Multicomp	MC 0.1W 0805 1% 1K
R11, R12	100 kΩ, 1%, 0603, SMD resistor	Multicomp	MC 0.063W 0603 1% 100K
R13	0 Ω, 1%, 0603, SMD resistor	Multicomp	MC 0.063W 0603 0R
R14	10 kΩ, 1%, 0603, SMD resistor	Multicomp	MC 0.063W 0603 1% 10K
R15, R16	2.2 kΩ, 1%, 0603 SMD resistor	Multicomp	MC 0.063W 0603 1% 2K2
T1 to T8	Black test point	Vero Technologies	20-2137
U1	Precision, low noise, CMOS, rail-to-rail, input/output operational amplifiers	Analog Devices	AD8606ARZ
U2	1 MSPS, 12-bit impedance converter network analyzer	Analog Devices	AD5933BRSZ
U3	USB microcontroller, LFCSP-56	Cypress Semiconductor	CY7C68013-56LFC
U4	I ² C serial EEPROM, 64k, 2.5 V, 8-SOIC	Microchip Technologies	24LC64-I/SN
U5, U6	High accuracy anyCAP [®] 200 mA low dropout linear regulator	Analog Devices	ADP3303ARZ-3.3
Y1	24 MHz SMD crystal, XTAL-CM309S	AEL Crystals	X24M000000S244
Y2	3.3 V, 16 MHz clock oscillator	AEL Crystals	AEL4303

¹ Do not install.

RELATED LINKS

Resource	Description
AD5933	1 MSPS, 12-bit impedance converter network analyzer
AD9834	20 mW power, 2.3 V to 5.5 V, 75 MHz complete DDS
ADF4001	200 MHz clock generator PLL
ADuC7020	Precision analog microcontroller, 12-bit analog I/O, ARM7TDMI® MCU
ADCMP601	Rail-to-rail, very fast, 2.5 V to 5.5 V, single-supply TTL/CMOS comparator in a 6-lead SC70 package
ADP3303	High accuracy anyCAP® 200 mA low dropout linear regulator
AD8606	Precision, low noise, CMOS, rail-to-rail, input/output operational amplifiers

NOTES

**ESD Caution**

ESD (electrostatic discharge) sensitive device. Charged devices and circuit boards can discharge without detection. Although this product features patented or proprietary protection circuitry, damage may occur on devices subjected to high energy ESD. Therefore, proper ESD precautions should be taken to avoid performance degradation or loss of functionality.

Legal Terms and Conditions

By using the evaluation board discussed herein (together with any tools, components documentation or support materials, the "Evaluation Board"), you are agreeing to be bound by the terms and conditions set forth below ("Agreement") unless you have purchased the Evaluation Board, in which case the Analog Devices Standard Terms and Conditions of Sale shall govern. Do not use the Evaluation Board until you have read and agreed to the Agreement. Your use of the Evaluation Board shall signify your acceptance of the Agreement. This Agreement is made by and between you ("Customer") and Analog Devices, Inc. ("ADI"), with its principal place of business at One Technology Way, Norwood, MA 02062, USA. Subject to the terms and conditions of the Agreement, ADI hereby grants to Customer a free, limited, personal, temporary, non-exclusive, non-sublicensable, non-transferable license to use the Evaluation Board FOR EVALUATION PURPOSES ONLY. Customer understands and agrees that the Evaluation Board is provided for the sole and exclusive purpose referenced above, and agrees not to use the Evaluation Board for any other purpose. Furthermore, the license granted is expressly made subject to the following additional limitations: Customer shall not (i) rent, lease, display, sell, transfer, assign, sublicense, or distribute the Evaluation Board; and (ii) permit any Third Party to access the Evaluation Board. As used herein, the term "Third Party" includes any entity other than ADI, Customer, their employees, affiliates and in-house consultants. The Evaluation Board is NOT sold to Customer; all rights not expressly granted herein, including ownership of the Evaluation Board, are reserved by ADI. CONFIDENTIALITY. This Agreement and the Evaluation Board shall all be considered the confidential and proprietary information of ADI. Customer may not disclose or transfer any portion of the Evaluation Board to any other party for any reason. Upon discontinuation of use of the Evaluation Board or termination of this Agreement, Customer agrees to promptly return the Evaluation Board to ADI. ADDITIONAL RESTRICTIONS. Customer may not disassemble, decompile or reverse engineer chips on the Evaluation Board. Customer shall inform ADI of any occurred damages or any modifications or alterations it makes to the Evaluation Board, including but not limited to soldering or any other activity that affects the material content of the Evaluation Board. Modifications to the Evaluation Board must comply with applicable law, including but not limited to the RoHS Directive. TERMINATION. ADI may terminate this Agreement at any time upon giving written notice to Customer. Customer agrees to return to ADI the Evaluation Board at that time. LIMITATION OF LIABILITY. THE EVALUATION BOARD PROVIDED HEREUNDER IS PROVIDED "AS IS" AND ADI MAKES NO WARRANTIES OR REPRESENTATIONS OF ANY KIND WITH RESPECT TO IT. ADI SPECIFICALLY DISCLAIMS ANY REPRESENTATIONS, ENDORSEMENTS, GUARANTEES, OR WARRANTIES, EXPRESS OR IMPLIED, RELATED TO THE EVALUATION BOARD INCLUDING, BUT NOT LIMITED TO, THE IMPLIED WARRANTY OF MERCHANTABILITY, TITLE, FITNESS FOR A PARTICULAR PURPOSE OR NON-INFRINGEMENT OF INTELLECTUAL PROPERTY RIGHTS. IN NO EVENT WILL ADI AND ITS LICENSORS BE LIABLE FOR ANY INCIDENTAL, SPECIAL, INDIRECT, OR CONSEQUENTIAL DAMAGES RESULTING FROM CUSTOMER'S POSSESSION OR USE OF THE EVALUATION BOARD, INCLUDING BUT NOT LIMITED TO LOST PROFITS, DELAY COSTS, LABOR COSTS OR LOSS OF GOODWILL. ADI'S TOTAL LIABILITY FROM ANY AND ALL CAUSES SHALL BE LIMITED TO THE AMOUNT OF ONE HUNDRED US DOLLARS (\$100.00). EXPORT. Customer agrees that it will not directly or indirectly export the Evaluation Board to another country, and that it will comply with all applicable United States federal laws and regulations relating to exports. GOVERNING LAW. This Agreement shall be governed by and construed in accordance with the substantive laws of the Commonwealth of Massachusetts (excluding conflict of law rules). Any legal action regarding this Agreement will be heard in the state or federal courts having jurisdiction in Suffolk County, Massachusetts, and Customer hereby submits to the personal jurisdiction and venue of such courts. The United Nations Convention on Contracts for the International Sale of Goods shall not apply to this Agreement and is expressly disclaimed.

Looking for pricing, stock, or lifecycle information?

Click below to explore more details on WIN SOURCE:

 [View EVAL-AD5933EBZ on WIN SOURCE](#)

 [Analog Devices Inc. Information](#)

Optimize Your Supply Chain with WIN SOURCE Solutions

-  Global Sourcing Solution
-  Obsolete Management
-  Cost Control Management
-  Shortage Management
-  Alternative Solution
-  Excess Inventory Management