



**THE DATASHEET OF  
CY62128BLL-70ZRXE**



# 128K x 8 Static RAM

## Features

- **Temperature Ranges**
  - Commercial: 0°C to 70°C
  - Industrial: -40°C to 85°C
  - Automotive: -40°C to 125°C
- **4.5V – 5.5V operation**
- **CMOS for optimum speed/power**
- **Low active power**  
(70 ns, LL version, Commercial, Industrial)
  - 82.5 mW (max.) (15 mA)
- **Low standby power**  
(70 ns, LL version, Commercial, Industrial)
  - 110 μW (max.) (15 μA)
- **Automatic power-down when deselected**
- **TTL-compatible inputs and outputs**
- **Easy memory expansion with  $\overline{CE}_1$ ,  $CE_2$ , and  $\overline{OE}$  options**

## Functional Description<sup>[1]</sup>

The CY62128B is a high-performance CMOS static RAM organized as 131,072 words by 8 bits. Easy memory expansion is provided by an active LOW Chip Enable ( $\overline{CE}_1$ ), an active HIGH Chip Enable ( $CE_2$ ), an active LOW Output Enable ( $\overline{OE}$ ), and three-state drivers. This device has an automatic power-down feature that reduces power consumption by more than 75% when deselected.

Writing to the device is accomplished by taking Chip Enable One ( $\overline{CE}_1$ ) and Write Enable ( $\overline{WE}$ ) inputs LOW and Chip Enable Two ( $CE_2$ ) input HIGH. Data on the eight I/O pins ( $I/O_0$  through  $I/O_7$ ) is then written into the location specified on the address pins ( $A_0$  through  $A_{16}$ ).

Reading from the device is accomplished by taking Chip Enable One ( $\overline{CE}_1$ ) and Output Enable ( $\overline{OE}$ ) LOW while forcing Write Enable ( $\overline{WE}$ ) and Chip Enable Two ( $CE_2$ ) HIGH. Under these conditions, the contents of the memory location specified by the address pins will appear on the I/O pins.

The eight input/output pins ( $I/O_0$  through  $I/O_7$ ) are placed in a high-impedance state when the device is deselected ( $\overline{CE}_1$  HIGH or  $CE_2$  LOW), the outputs are disabled ( $\overline{OE}$  HIGH), or during a write operation ( $\overline{CE}_1$  LOW,  $CE_2$  HIGH, and  $\overline{WE}$  LOW).

The CY62128B is available in a standard 450-mil-wide SOIC, 32-pin TSOP type I and STSOP packages.

## Logic Block Diagram

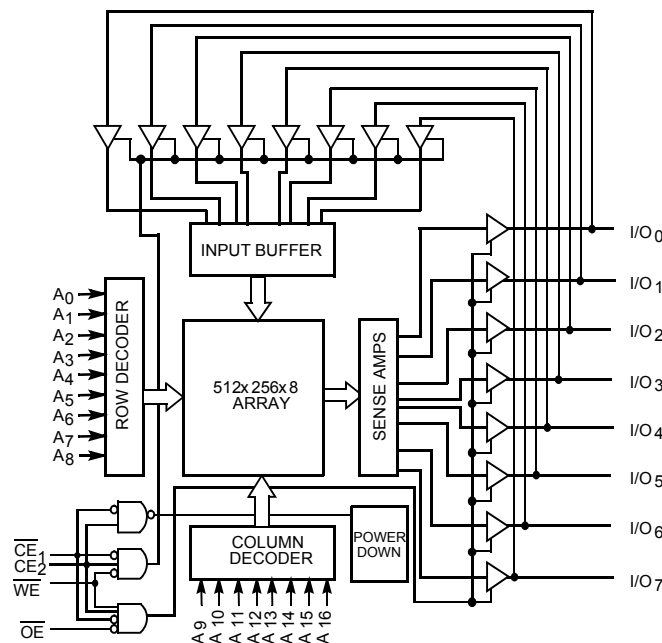

### Note:

1. For best practice recommendations, please refer to the Cypress application note "System Design Guidelines" on <http://www.cypress.com>.

**Product Portfolio**

Product		V <sub>CC</sub> Range (V)			Speed (ns)	Power Dissipation			
						Operating, I <sub>CC</sub> (mA)		Standby, I <sub>SB2</sub> (μA)	
		Min.	Typ. <sup>[2]</sup>	Max.		Typ. <sup>[2]</sup>	Max.	Typ. <sup>[2]</sup>	Max.
CY62128BLL	Industrial	4.5	5.0	5.5	55	7.5	20	2.5	15
	Industrial				70	6	15	2.5	15
	Automotive				70	6	25	2.5	25

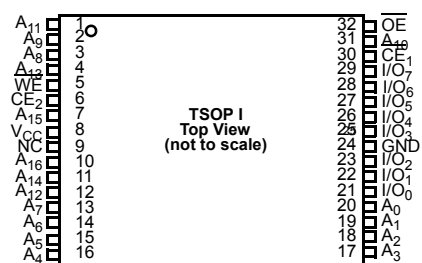
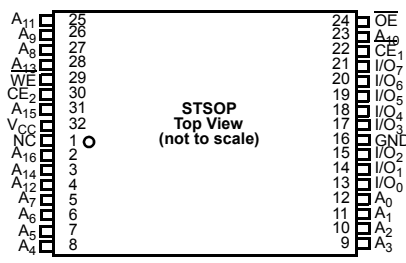
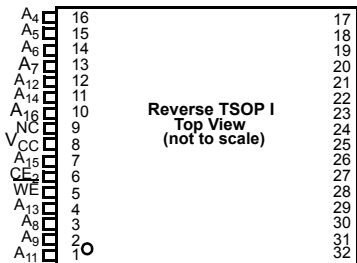
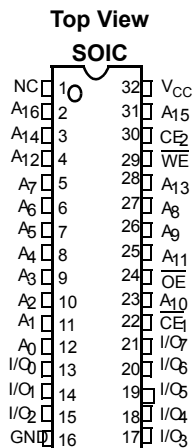
**Pin Configurations**

**Pin Definitions**

Input	<b>A<sub>0</sub>-A<sub>16</sub></b> . Address Inputs
Input/Output	<b>I/O<sub>0</sub>-I/O<sub>7</sub></b> . Data lines. Used as input or output lines depending on operation
Input/Control	<b>WE</b> . Write Enable, Active LOW. When selected LOW, a WRITE is conducted. When selected HIGH, a READ is conducted.
Input/Control	<b>CE<sub>1</sub></b> . Chip Enable 1, Active LOW.
Input/Control	<b>CE<sub>2</sub></b> . Chip Enable 2, Active HIGH.
Input/Control	<b>OE</b> . Output Enable, Active LOW. Controls the direction of the I/O pins. When LOW, the I/O pins behave as outputs. When deasserted HIGH, I/O pins are three-stated, and act as input data pins
Ground	<b>GND</b> . Ground for the device
Power Supply	<b>V<sub>CC</sub></b> . Power supply for the device

**Notes:**

2. Typical values are included for reference only and are not tested or guaranteed. Typical values are an average of the distribution across normal production variations as measured at V<sub>CC</sub> = 5.0V, T<sub>A</sub> = 25 °C, and t<sub>AA</sub> = 70 ns.

**Maximum Ratings**

(Above which the useful life may be impaired. For user guidelines, not tested.)

Storage Temperature ..... -65°C to +150°C  
 Ambient Temperature with Power Applied..... -55°C to +125°C  
 Supply Voltage on V<sub>CC</sub> to Relative GND<sup>[3]</sup> .... -0.5V to +7.0V  
 DC Voltage Applied to Outputs in High-Z State<sup>[3]</sup> ..... -0.5V to V<sub>CC</sub> + 0.5V  
 DC Input Voltage<sup>[3]</sup>..... -0.5V to V<sub>CC</sub> + 0.5V

Current into Outputs (LOW)..... 20 mA  
 Static Discharge Voltage..... > 2001V (per MIL-STD-883, Method 3015)  
 Latch-up Current..... > 200 mA

**Operating Range**

Range	Ambient Temperature (T <sub>A</sub> ) <sup>[4]</sup>	V <sub>CC</sub>
Commercial	0°C to +70°C	5V ± 10%
Industrial	-40°C to +85°C	5V ± 10%
Automotive	-40°C to +125°C	5V ± 10%

**Electrical Characteristics Over the Operating Range**

Parameter	Description	Test Conditions	CY62128B-55			CY62128B-70			Unit
			Min.	Typ. <sup>[2]</sup>	Max.	Min.	Typ. <sup>[2]</sup>	Max.	
V <sub>OH</sub>	Output HIGH Voltage	V <sub>CC</sub> = Min., I <sub>OH</sub> = -1.0 mA	2.4			2.4			V
V <sub>OL</sub>	Output LOW Voltage	V <sub>CC</sub> = Min., I <sub>OL</sub> = 2.1 mA			0.4			0.4	V
V <sub>IH</sub>	Input HIGH Voltage		2.2		V <sub>CC</sub> + 0.3	2.2		V <sub>CC</sub> + 0.3	V
V <sub>IL</sub>	Input LOW Voltage <sup>[3]</sup>		-0.3		0.8	-0.3		0.8	V
I <sub>IX</sub>	Input Load Current	GND ≤ V <sub>I</sub> ≤ V <sub>CC</sub>	-1		+1	-1		+1	μA
		Automotive				-10		+10	μA
I <sub>OZ</sub>	Output Leakage Current	GND ≤ V <sub>I</sub> ≤ V <sub>CC</sub> , Output Disabled	-1		+1	-1		+1	μA
		Automotive				-10		+10	μA
I <sub>OS</sub>	Output Short Circuit Current <sup>[5]</sup>	V <sub>CC</sub> = Max., V <sub>OUT</sub> = GND			-300			-300	mA
I <sub>CC</sub>	V <sub>CC</sub> Operating Supply Current	V <sub>CC</sub> = Max., I <sub>OUT</sub> = 0 mA, f = f <sub>MAX</sub> = 1/t <sub>RC</sub>		7.5	20		6	15	mA
		Automotive					6	25	mA
I <sub>SB1</sub>	Automatic CE Power-down Current —TTL Inputs	Max. V <sub>CC</sub> , CE <sub>1</sub> ≥ V <sub>IH</sub> or CE <sub>2</sub> ≤ V <sub>IL</sub> , V <sub>IN</sub> ≥ V <sub>IH</sub> or V <sub>IN</sub> ≤ V <sub>IL</sub> , f = f <sub>MAX</sub>		0.1	2		0.1	1	mA
		Automotive					0.1	2	mA
I <sub>SB2</sub>	Automatic CE Power-down Current —CMOS Inputs	Max. V <sub>CC</sub> , CE <sub>1</sub> ≥ V <sub>CC</sub> - 0.3V, or CE <sub>2</sub> ≤ 0.3V, V <sub>IN</sub> ≥ V <sub>CC</sub> - 0.3V, or V <sub>IN</sub> ≤ 0.3V, f = 0		2.5	15		2.5	15	μA
		Automotive					2.5	25	μA

**Thermal Resistance<sup>[6]</sup>**

Parameter	Description	Test Conditions	32 SOIC	32 TSOP	32 STSOP	32 RTSOP	Unit
θ <sub>JA</sub>	Thermal Resistance (Junction to Ambient)	Test conditions follow standard test methods and procedures for measuring thermal impedance, per EIA / JESD51.	66.17	97.44	105.14	97.44	°C/W
θ <sub>JC</sub>	Thermal Resistance (Junction to Case)		30.87	26.05	14.09	26.05	°C/W

**Note:**

- V<sub>IL</sub> (min.) = -2.0V for pulse durations of less than 20 ns.
- T<sub>A</sub> is the "Instant On" case temperature.
- Not more than one output should be shorted at one time. Duration of the short circuit should not exceed 30 seconds.
- Tested initially and after any design or process changes that may affect these parameters.

**Capacitance<sup>[6]</sup>**

Parameter	Description	Test Conditions	Max.	Unit
$C_{IN}$	Input Capacitance	$T_A = 25^\circ\text{C}, f = 1\text{ MHz},$ $V_{CC} = 5.0\text{V}$	9	pF
$C_{OUT}$	Output Capacitance		9	pF

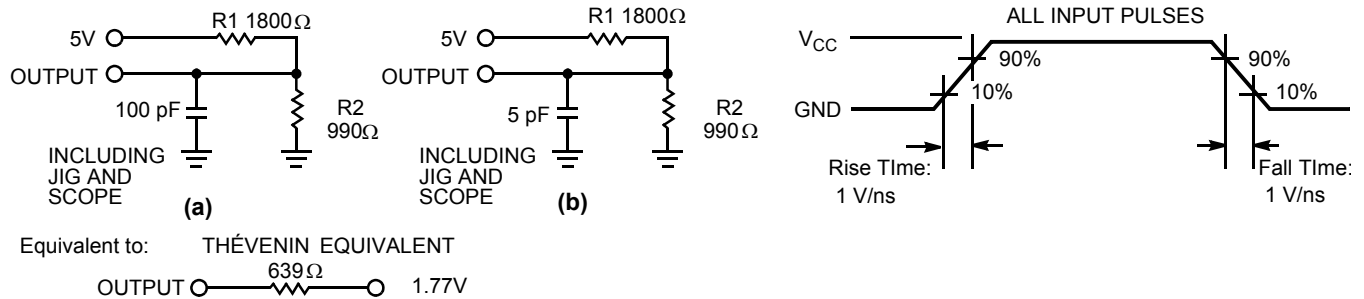
**AC Test Loads and Waveforms**

**Data Retention Characteristics** (Over the Operating Range for “LL” version only)

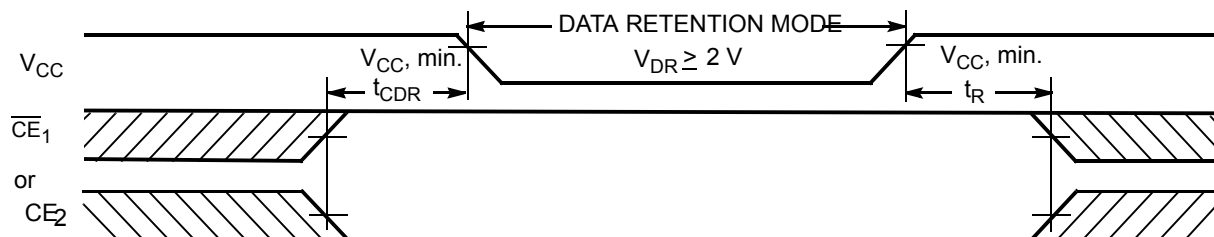
Parameter	Description	Conditions	Min.	Typ.	Max.	Unit
$V_{DR}$	$V_{CC}$ for Data Retention		2.0			V
$I_{CCDR}$	Data Retention Current	$V_{CC} = V_{DR} = 2.0\text{V}, \overline{CE}_1 \geq V_{CC} - 0.3\text{V},$ or $\overline{CE}_2 \leq 0.3\text{V}, V_{IN} \geq V_{CC} - 0.3\text{V}$ or, $V_{IN} \leq 0.3\text{V}$		1.5	15	$\mu\text{A}$
$t_{CDR}$	Chip Deselect to Data Retention Time		0			ns
$t_R$	Operation Recovery Time		70			ns

**Data Retention Waveform**

**Switching Characteristics<sup>[7]</sup> Over the Operating Range**

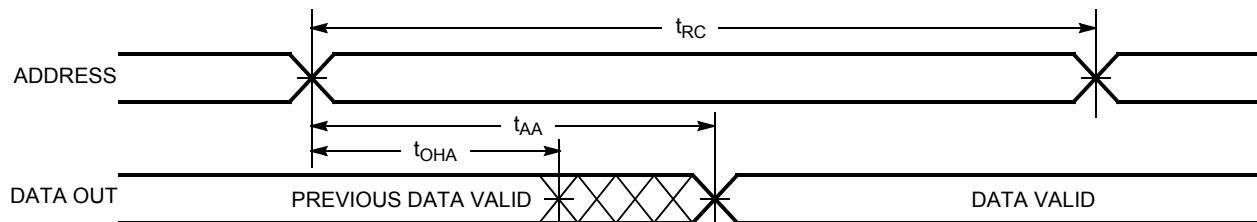
Parameter	Description	62128B-55		62128B-70		Unit
		Min.	Max.	Min.	Max.	
<b>READ CYCLE</b>						
$t_{RC}$	Read Cycle Time	55		70		ns
$t_{AA}$	Address to Data Valid		55		70	ns
$t_{OHA}$	Data Hold from Address Change	5		5		ns
$t_{ACE}$	$\overline{CE}_1$ LOW to Data Valid, $CE_2$ HIGH to Data Valid		55		70	ns
$t_{DOE}$	$\overline{OE}$ LOW to Data Valid		20		35	ns
$t_{LZOE}$	$\overline{OE}$ LOW to Low Z	0		0		ns
$t_{HZOE}$	$\overline{OE}$ HIGH to High Z <sup>[8, 9]</sup>		20		25	ns
$t_{LZCE}$	$\overline{CE}_1$ LOW to Low Z, $CE_2$ HIGH to Low Z <sup>[9]</sup>	5		5		ns
$t_{HZCE}$	$\overline{CE}_1$ HIGH to High Z, $CE_2$ LOW to High Z <sup>[8, 9]</sup>		20		25	ns
$t_{PU}$	$\overline{CE}_1$ LOW to Power-up, $CE_2$ HIGH to Power-up	0		0		ns
$t_{PD}$	$\overline{CE}_1$ HIGH to Power-down, $CE_2$ LOW to Power-down		55		70	ns
<b>WRITE CYCLE<sup>[10]</sup></b>						
$t_{WC}$	Write Cycle Time	55		70		ns
$t_{SCE}$	$\overline{CE}_1$ LOW to Write End, $CE_2$ HIGH to Write End	45		60		ns
$t_{AW}$	Address Set-up to Write End	45		60		ns
$t_{HA}$	Address Hold from Write End	0		0		ns
$t_{SA}$	Address Set-up to Write Start	0		0		ns
$t_{PWE}$	$\overline{WE}$ Pulse Width	45		50		ns
$t_{SD}$	Data Set-up to Write End	25		30		ns
$t_{HD}$	Data Hold from Write End	0		0		ns
$t_{LZWE}$	$\overline{WE}$ HIGH to Low Z <sup>[9]</sup>	5		5		ns
$t_{HZWE}$	$\overline{WE}$ LOW to High Z <sup>[8, 9]</sup>		20		25	ns

**Switching Waveforms**
**Read Cycle No.1<sup>[12, 13]</sup>**

**Notes:**

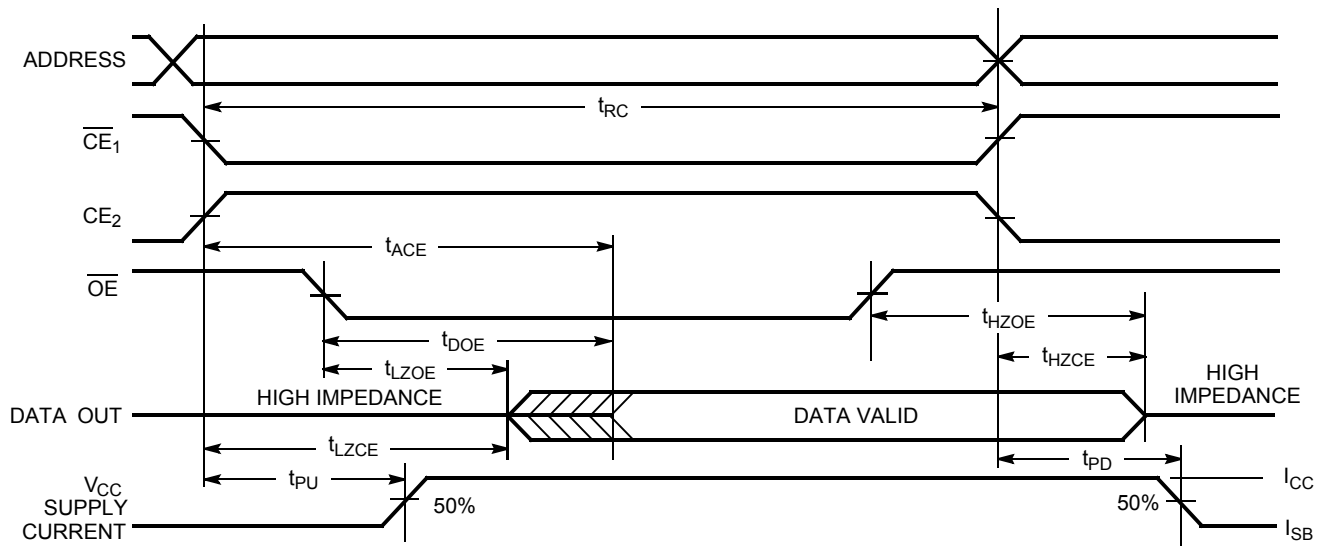
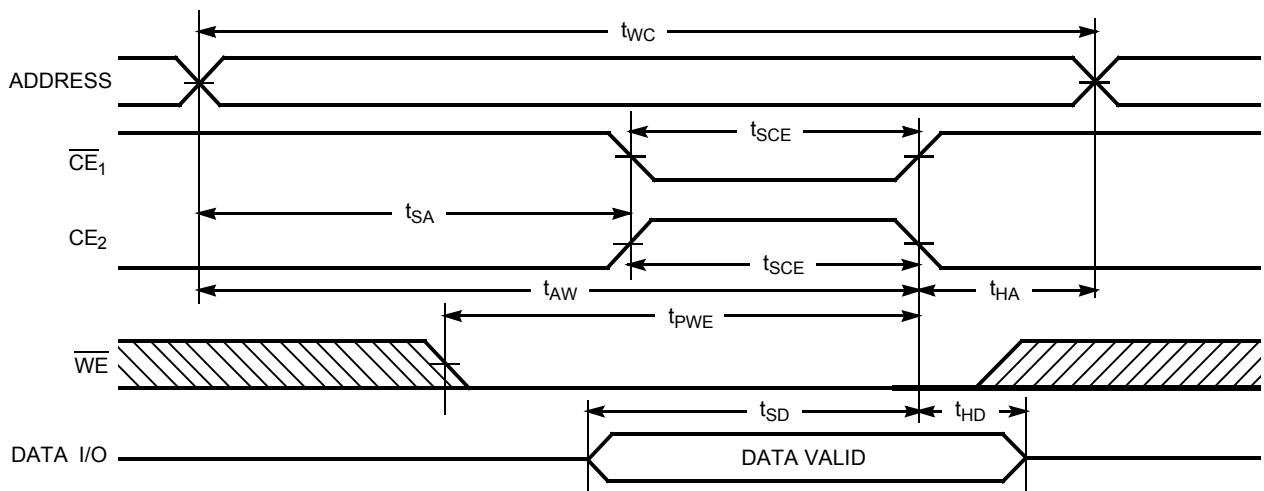
7. Test conditions assume signal transition time of 5 ns or less, timing reference levels of 1.5V, input pulse levels of 0 to 3.0V, and output loading of the specified  $I_{OL}/I_{OH}$  and 100-pF load capacitance.
8.  $t_{HZOE}$ ,  $t_{HZCE}$ , and  $t_{HZWE}$  are specified with a load capacitance of 5 pF as in (b) of AC Test Loads. Transition is measured  $\pm 500$  mV from steady-state voltage.
9. At any given temperature and voltage condition,  $t_{HZCE}$  is less than  $t_{LZCE}$ ,  $t_{HZOE}$  is less than  $t_{LZOE}$ , and  $t_{HZWE}$  is less than  $t_{LZWE}$  for any given device.
10. The internal write time of the memory is defined by the overlap of  $\overline{CE}_1$  LOW,  $CE_2$  HIGH, and  $\overline{WE}$  LOW.  $\overline{CE}_1$  and  $\overline{WE}$  must be LOW and  $CE_2$  HIGH to initiate a write, and the transition of any of these signals can terminate the write. The input data set-up and hold timing should be referenced to the leading edge of the signal that terminates the write.
11. No input may exceed  $V_{CC} + 0.5V$ .
12. Device is continuously selected.  $\overline{OE}$ ,  $\overline{CE}_1 = V_{IL}$ ,  $CE_2 = V_{IH}$ .
13.  $\overline{WE}$  is HIGH for read cycle.

**Switching Waveforms (continued)**
**Read Cycle No. 2 ( $\overline{OE}$  Controlled)<sup>[13, 14]</sup>**

**Write Cycle No. 1 ( $\overline{CE}_1$  or  $CE_2$  Controlled)<sup>[15, 16]</sup>**

**Notes:**

14. Address valid prior to or coincident with  $\overline{CE}_1$  transition LOW and  $CE_2$  transition HIGH.

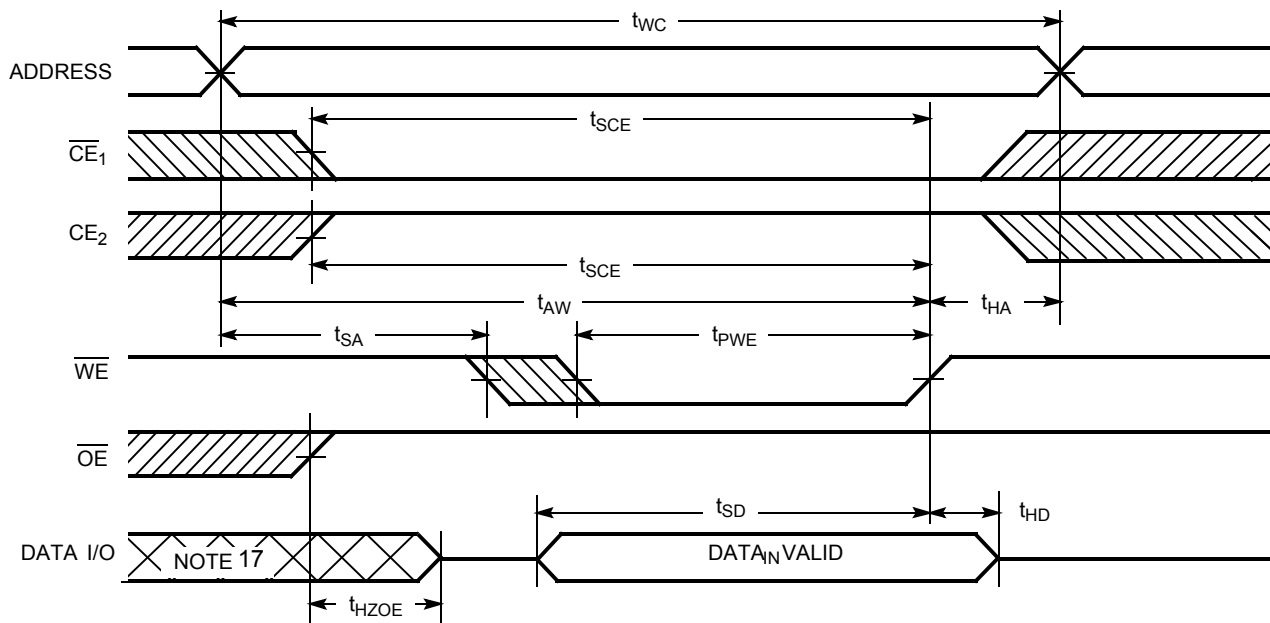
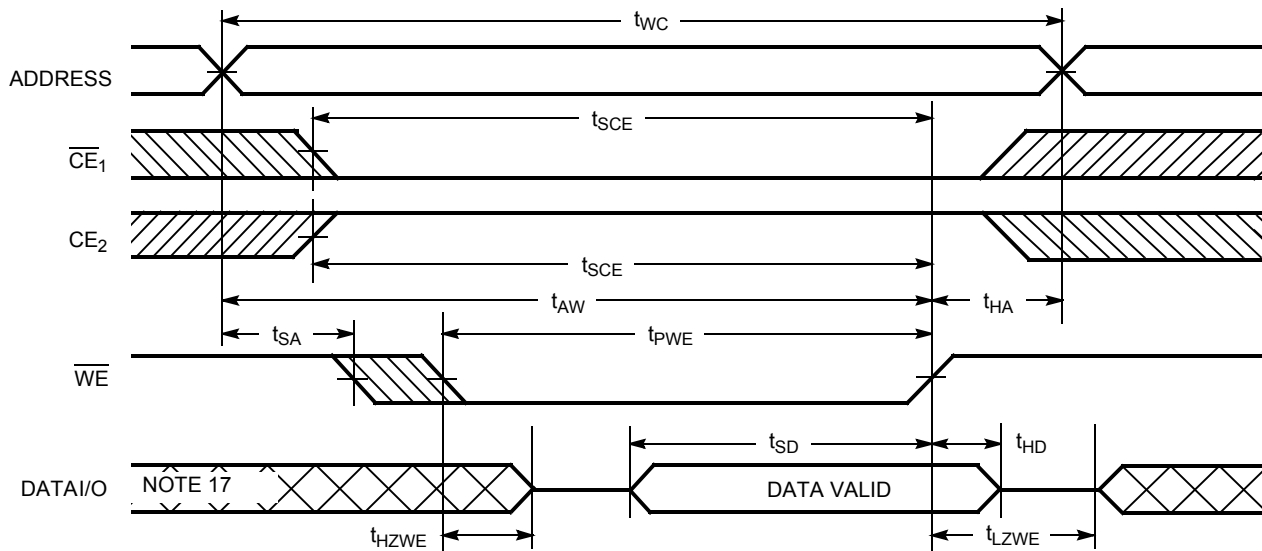
15. Data I/O is high impedance if  $\overline{OE} = V_{IH}$ .

16. If  $\overline{CE}_1$  goes HIGH or  $CE_2$  goes LOW simultaneously with  $\overline{WE}$  going HIGH, the output remains in a high-impedance state.

**Switching Waveforms (continued)**
**Write Cycle No. 2 ( $\overline{WE}$  Controlled,  $\overline{OE}$  HIGH During Write)<sup>[15, 16]</sup>**

**Write Cycle No.3 ( $\overline{WE}$  Controlled,  $\overline{OE}$  LOW)<sup>[15, 16]</sup>**

**Note:**

17. During this period the I/Os are in the output state and input signals should not be applied.

**Truth Table**

$\overline{CE}_1$	$\overline{CE}_2$	$\overline{OE}$	$\overline{WE}$	I/O <sub>0</sub> -I/O <sub>7</sub>	Mode	Power
H	X	X	X	High Z	Power-down	Standby (I <sub>SB</sub> )
X	L	X	X	High Z	Power-down	Standby (I <sub>SB</sub> )
L	H	L	H	Data Out	Read	Active (I <sub>CC</sub> )
L	H	X	L	Data In	Write	Active (I <sub>CC</sub> )
L	H	H	H	High Z	Selected, Outputs Disabled	Active (I <sub>CC</sub> )

**Ordering Information**

Speed (ns)	Ordering Code	Package Name	Package Type	Operating Range
55	CY62128BLL-55SI	S34	32-Lead 450-Mil SOIC	Industrial
	CY62128BLL-55SXI	S34	32-Lead 450-Mil SOIC (Pb-free)	Industrial
	CY62128BLL-55SC	S34	32-Lead 450-Mil SOIC	Commercial
	CY62128BLL-55SXC	S34	32-Lead 450-Mil SOIC (Pb-free)	Commercial
	CY62128BLL-55ZI	Z32	32-Lead TSOP Type I	Industrial
	CY62128BLL-55ZXI	Z32	32-Lead TSOP Type I (Pb-free)	Industrial
	CY62128BLL-55ZAI	ZA32	32-Lead STSOP Type I	Industrial
	CY62128BLL-55ZAXI	ZA32	32-Lead STSOP Type I (Pb-free)	Industrial
70	CY62128BLL-70SI	S34	32-Lead 450-Mil SOIC I	Industrial
	CY62128BLL-70SXI	S34	32-Lead 450-Mil SOIC I (Pb-free)	Industrial
	CY62128BLL-70SC	S34	32-Lead 450-Mil SOIC I	Commercial
	CY62128BLL-70SXC	S34	32-Lead 450-Mil SOIC I (Pb-free)	Commercial
	CY62128BLL-70SE	S34	32-Lead 450-Mil SOIC I	Automotive
	CY62128BLL-70SXE	S34	32-Lead 450-Mil SOIC I (Pb-free)	Automotive
	CY62128BLL-70ZI	Z32	32-Lead TSOP Type I	Industrial
	CY62128BLL-70ZXI	Z32	32-Lead TSOP Type I (Pb-free)	Industrial
	CY62128BLL-70ZC	Z32	32-Lead TSOP Type I	Commercial
	CY62128BLL-70ZXC	Z32	32-Lead TSOP Type I (Pb-free)	Commercial
	CY62128BLL-70ZE	Z32	32-Lead TSOP Type I	Automotive
	CY62128BLL-70ZXE	Z32	32-Lead TSOP Type I (Pb-free)	Automotive
	CY62128BLL-70ZAI	ZA32	32-Lead STSOP Type I	Industrial
	CY62128BLL-70ZAXI	ZA32	32-Lead STSOP Type I (Pb-free)	Industrial
	CY62128BLL-70ZAE	ZA32	32-Lead STSOP Type I	Automotive
	CY62128BLL-70ZAXE	ZA32	32-Lead STSOP Type I (Pb-free)	Automotive
CY62128BLL-70ZRXE	ZR32	32-Lead Reverse TSOP Type I (Pb-free)	Automotive	

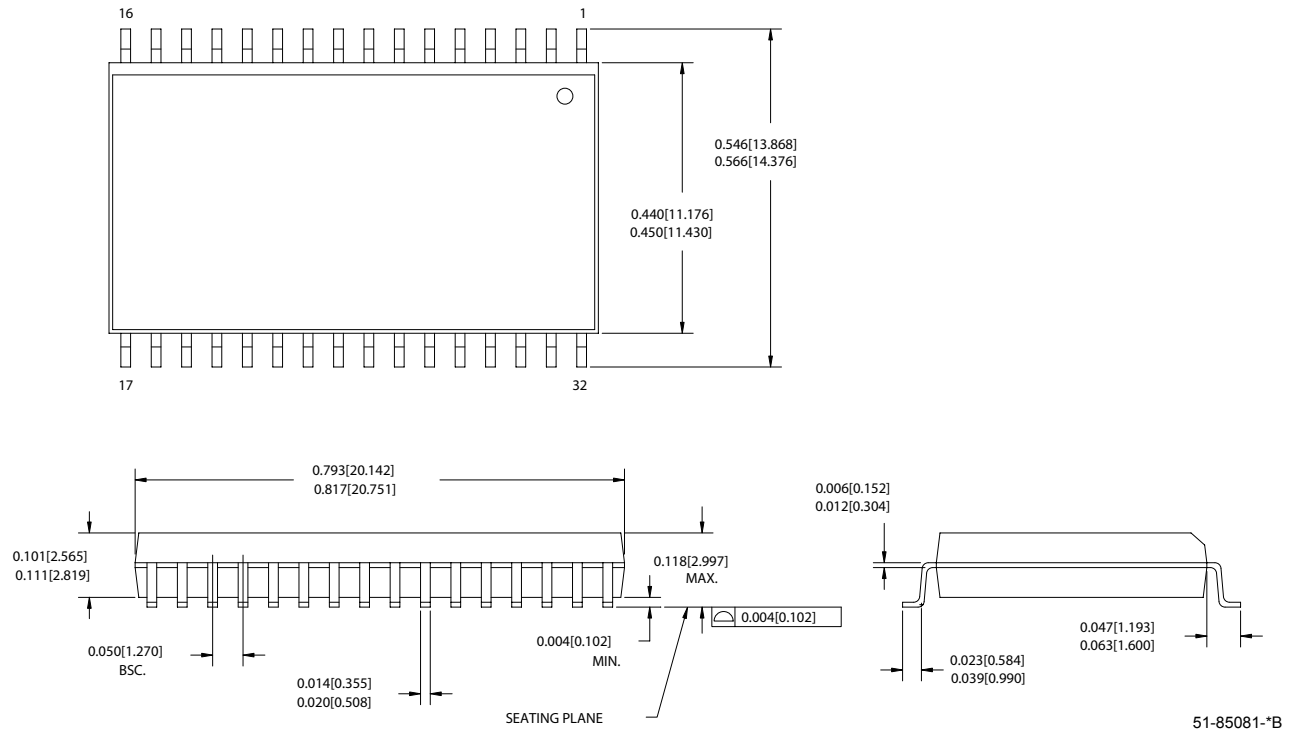
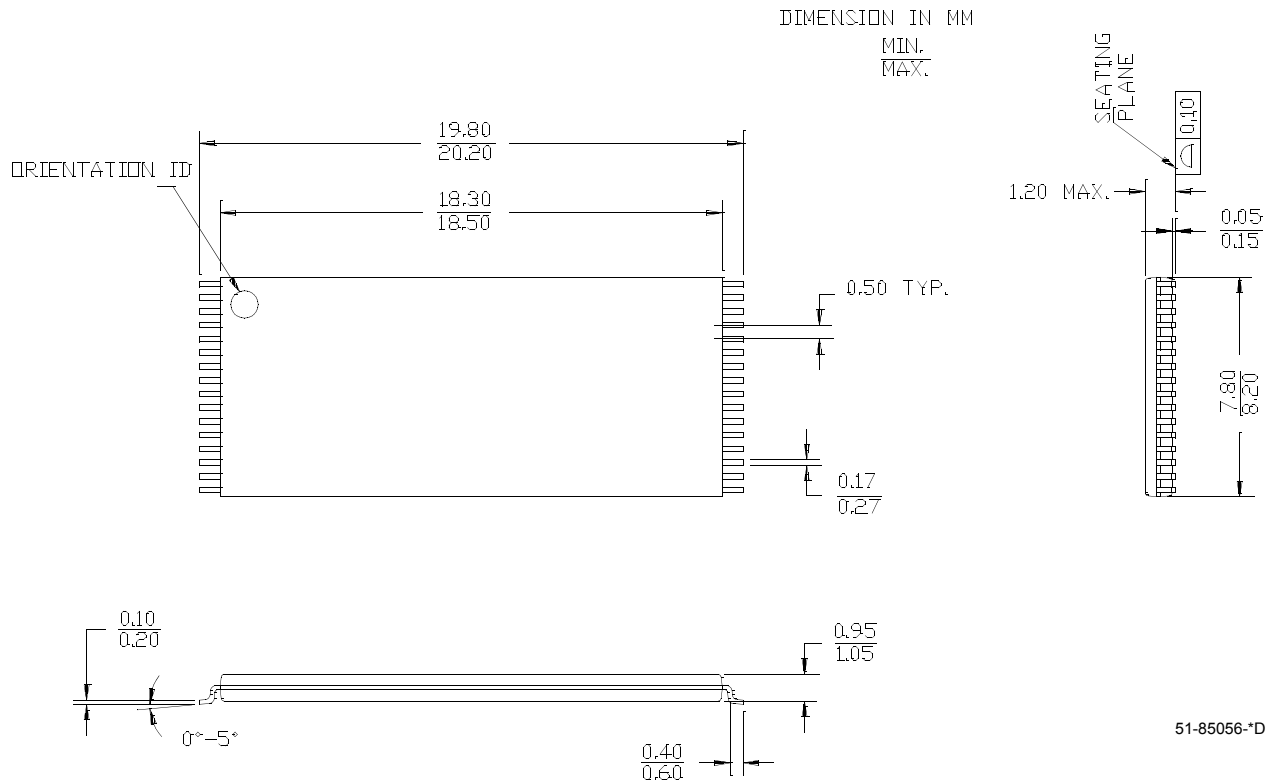
**Package Diagrams**
**32-Lead (450 MIL) Molded SOIC S34**

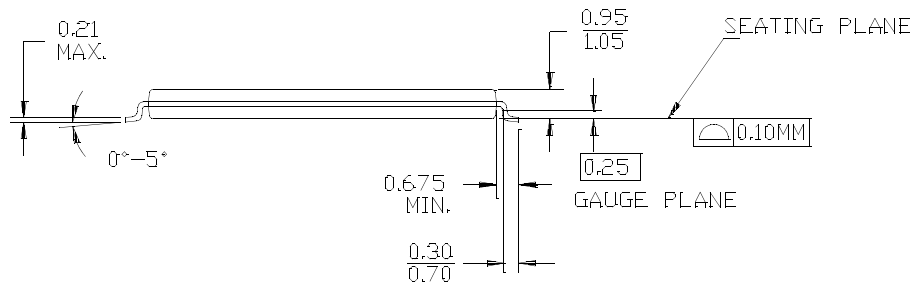
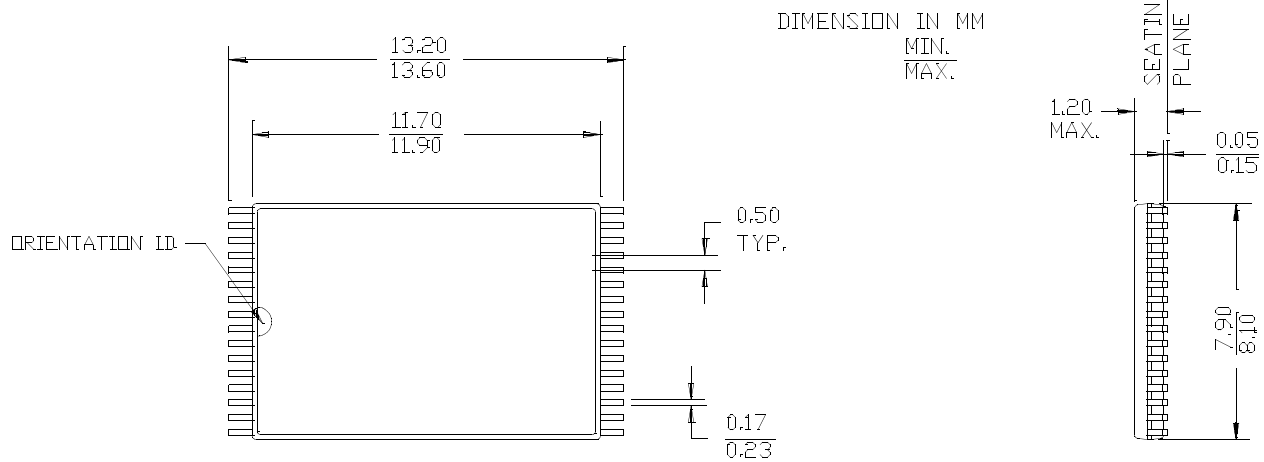
**32-Lead Thin Small Outline Package Type I (8x20 mm) Z32**

**Package Diagrams (continued)**
**32-Lead Shrunken Thin Small Outline Package (8x13.4 mm) ZA32**

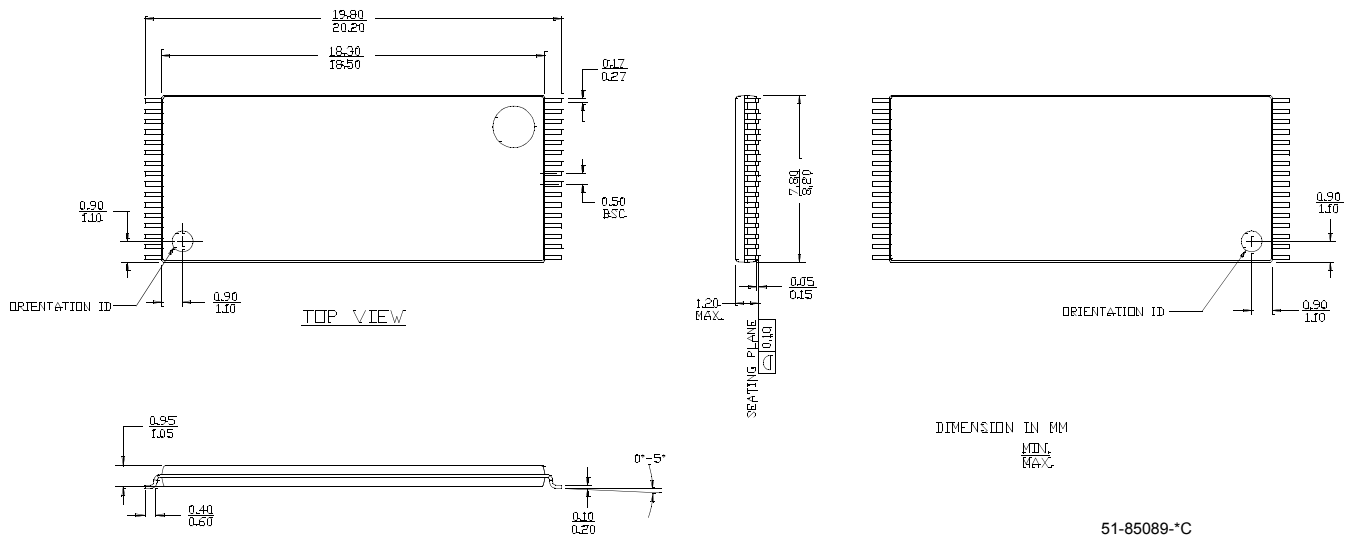
51-85094-\*D

**32-Lead Reverse Thin Small Outline Package ZR32**

51-85089-\*C



MoBL is a registered trademark of Cypress Semiconductor Corporation. All product and company names mentioned in this document are the trademarks of their respective holders.

**Document History Page**

Document Title: CY62128B MoBL <sup>®</sup> 128K x 8 Static RAM				
Document Number: 38-05300				
REV.	ECN NO.	Issue Date	Orig. of Change	Description of Change
**	116566	06/20/02	DSG	Changed from Spec number: 38-00524 to 38-05300
*A	126601	06/09/03	JUI	Changed CE to CE <sub>1</sub> and added CE <sub>2</sub> ≤ 0.3V in Data Retention Characteristics table Removed these part numbers from Ordering Information table: CY62128BLL-55ZC, CY62128BLL-55ZAC, CY62128BLL-55ZRC, CY62128BLL-70ZAC, CY62128BLL-70ZRI, CY62128BLL-70ZRC
*B	239134	See ECN	AJU	Added Thermal Resistance table Added Automotive product information
*C	321335	See ECN	AJU	Added Pb-free package information

## Looking for pricing, stock, or lifecycle information?

Click below to explore more details on WIN SOURCE:

-  [View CY62128BLL-70ZRXE on WIN SOURCE](#)
-  [Cypress Semiconductor Corp Information](#)

## Optimize Your Supply Chain with WIN SOURCE Solutions

-  Global Sourcing Solution
-  Obsolete Management
-  Cost Control Management
-  Shortage Management
-  Alternative Solution
-  Excess Inventory Management