



**THE DATASHEET OF
CDCLVD1213RGTT**



CDCLVD1213 1:4 Low Additive Jitter LVDS Buffer With Divider

1 Features

- 1:4 Differential Buffer
- Low Additive Jitter: < 300-fs RMS in 10-kHz to 20-MHz
- Low Output Skew of 20 ps (Maximum)
- Selectable Divider Ratio 1, /2, /4
- Universal Input Accepts LVDS, LVPECL, and CML
- 4 LVDS Outputs, ANSI EIA/TIA-644A Standard Compatible
- Clock Frequency: Up to 800 MHz
- Device Power Supply: 2.375 V to 2.625 V
- Industrial Temperature Range: –40°C to 85°C
- Packaged in 3 mm × 3 mm, 16-Pin VQFN (RGT)
- ESD Protection Exceeds 3-kV HBM, 1-kV CDM

2 Applications

- Telecommunications and Networking
- Medical Imaging
- Test and Measurement Equipment
- Wireless Communications
- General-Purpose Clocking

3 Description

The CDCLVD1213 clock buffer distributes an input clock to 4 pairs of differential LVDS clock outputs with low additive jitter for clock distribution. The input can either be LVDS, LVPECL, or CML.

The CDCLVD1213 contains a high performance divider for one output (QD) which can divide the input clock signal by a factor of 1, 2, or 4.

The CDCLVD1213 is specifically designed for driving 50-Ω transmission lines. The part supports a fail-safe function. The device incorporates an input hysteresis which prevents random oscillation of the outputs in the absence of an input signal.

The device operates in 2.5-V supply environment and is characterized from –40°C to 85°C (ambient temperature). The CDCLVD1213 is packaged in small, 16-pin, 3-mm × 3-mm VQFN package.

Device Information⁽¹⁾

PART NUMBER	PACKAGE	BODY SIZE (NOM)
CDCLVD1213	VQFN (16)	3.00 mm × 3.00 mm

(1) For all available packages, see the orderable addendum at the end of the data sheet.

Application Example

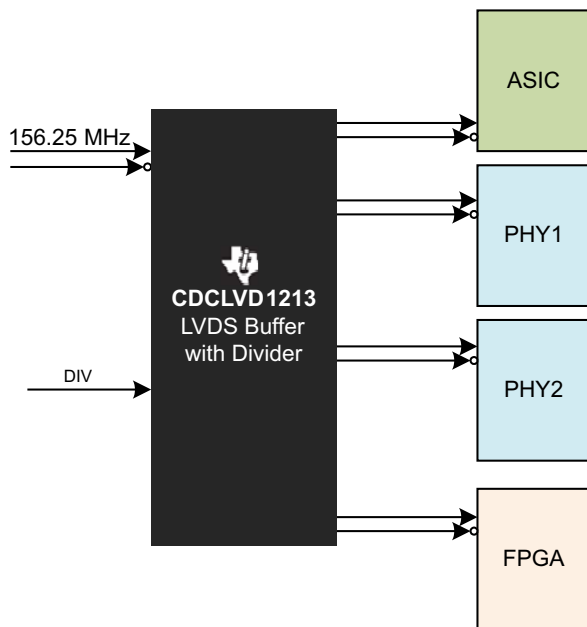

Copyright © 2016, Texas Instruments Incorporated

CDCLVD1213 Block Diagram

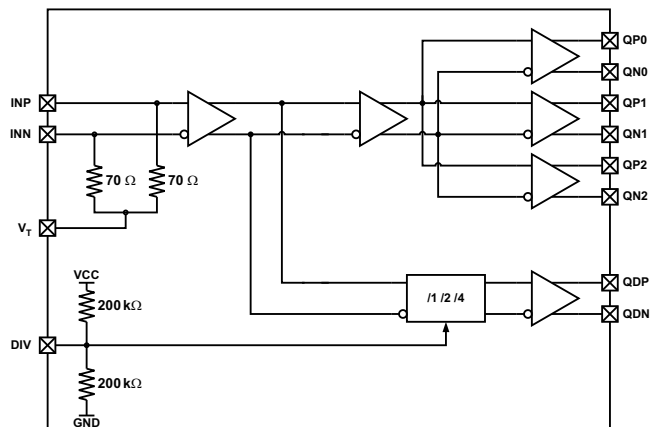

Copyright © 2016, Texas Instruments Incorporated



Table of Contents

1 Features 1 2 Applications 1 3 Description 1 4 Revision History 2 5 Pin Configuration and Functions 3 6 Specifications 3 6.1 Absolute Maximum Ratings 3 6.2 ESD Ratings..... 4 6.3 Recommended Operating Conditions 4 6.4 Thermal Information 4 6.5 Electrical Characteristics..... 4 6.6 Timing Requirements 5 6.7 Typical Characteristics 6 7 Parameter Measurement Information 7 8 Detailed Description 9 8.1 Overview 9 8.2 Functional Block Diagram 9 8.3 Feature Description..... 9	8.4 Device Functional Modes..... 9 9 Application and Implementation 12 9.1 Application Information..... 12 9.2 Typical Application 12 10 Power Supply Recommendations 14 11 Layout 15 11.1 Layout Guidelines 15 11.2 Layout Example 15 11.3 Thermal Considerations 15 12 Device and Documentation Support 16 12.1 Documentation Support 16 12.2 Receiving Notification of Documentation Updates 16 12.3 Community Resources..... 16 12.4 Trademarks 16 12.5 Electrostatic Discharge Caution..... 16 12.6 Glossary 16 13 Mechanical, Packaging, and Orderable Information 16
---	--

4 Revision History

NOTE: Page numbers for previous revisions may differ from page numbers in the current version.

Changes from Original (July 2010) to Revision A	Page
<ul style="list-style-type: none"> • Added <i>ESD Ratings</i> table, <i>Feature Description</i> section, <i>Device Functional Modes</i>, <i>Application and Implementation</i> section, <i>Power Supply Recommendations</i> section, <i>Layout</i> section, <i>Device and Documentation Support</i> section, and <i>Mechanical, Packaging, and Orderable Information</i> section. 	1

5 Pin Configuration and Functions

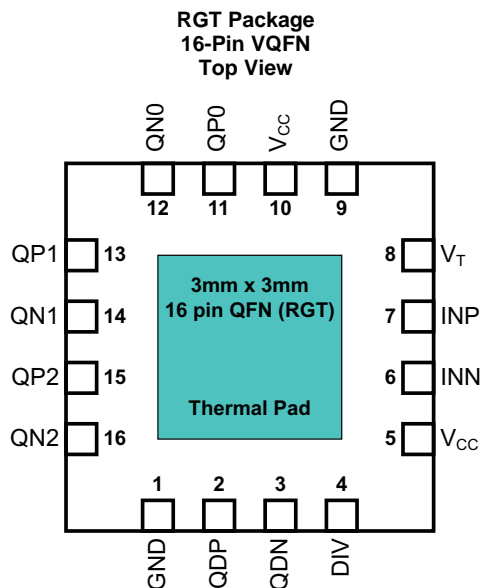

Pin Functions

PIN		TYPE	DESCRIPTION
NO.	NAME		
1, 9	GND	Ground	Device ground
2, 3	QDP, QDN	Output	Differential divided LVDS output pair
4	DIV	Input with an internal 200-k Ω pullup and pulldown	Divider selection – selects divider ratio for QD output (see Table 1).
5, 10	V _{CC}	Power	2.5-V supply for the device
6, 7	INN, INP	Input	Differential input pair
8	V _T	Input	Input for threshold voltage
11, 12	QP0, QN0	Output	Differential LVDS output pair number 0
13, 14	QP1, QN1	Output	Differential LVDS output pair number 1
15, 16	QP2, QN2	Output	Differential LVDS output pair number 2
—	Thermal Pad	—	See thermal management recommendations

6 Specifications

6.1 Absolute Maximum Ratings

over operating free-air temperature range (unless otherwise noted)⁽¹⁾

	MIN	MAX	UNIT
Supply voltage, V _{CC}	–0.3	2.8	V
Input voltage, V _I	–0.2	V _{CC} + 0.2	V
Output voltage, V _O	–0.2	V _{CC} + 0.2	V
Driver short-circuit current, I _{OSD}	See Note ⁽²⁾		
Storage temperature, T _{stg}	–65	150	°C

(1) Stresses beyond those listed under *Absolute Maximum Ratings* may cause permanent damage to the device. These are stress ratings only, which do not imply functional operation of the device at these or any other conditions beyond those indicated under *Recommended Operating Conditions*. Exposure to absolute-maximum-rated conditions for extended periods may affect device reliability.

(2) The output can handle the permanent short.

6.2 ESD Ratings

		VALUE	UNIT
$V_{(ESD)}$ Electrostatic discharge	Human-body model (HBM), per ANSI/ESDA/JEDEC JS-001 ⁽¹⁾	>3000	V
	Charged-device model (CDM), per JEDEC specification JESD22-C101 ⁽²⁾	>1000	

(1) Human-body model, 1.5-k Ω , 100-pF

(2) JEDEC document JEP157 states that 250-V CDM allows safe manufacturing with a standard ESD control process.

6.3 Recommended Operating Conditions

over operating free-air temperature range (unless otherwise noted)

		MIN	NOM	MAX	UNIT
V_{CC} Device supply voltage		2.375	2.5	2.625	V
T_A Ambient temperature		-40		85	°C

6.4 Thermal Information

THERMAL METRIC ⁽¹⁾		CDCLVD1213	UNIT
		RGT (VQFN)	
		16 PINS	
$R_{\theta JA}$ Junction-to-ambient thermal resistance		51.3	°C/W
$R_{\theta JC(top)}$ Junction-to-case (top) thermal resistance		85.4	°C/W
$R_{\theta JB}$ Junction-to-board thermal resistance		20.1	°C/W
ψ_{JT} Junction-to-top characterization parameter		1.3	°C/W
ψ_{JB} Junction-to-board characterization parameter		19.4	°C/W
$R_{\theta JC(bot)}$ Junction-to-case (bottom) thermal resistance		6	°C/W

(1) For more information about traditional and new thermal metrics, see the [Semiconductor and IC Package Thermal Metrics](#) application report.

6.5 Electrical Characteristics

$V_{CC} = 2.375\text{ V to }2.625\text{ V}$ and $T_A = -40^\circ\text{C to }85^\circ\text{C}$ (unless otherwise noted)

PARAMETER	TEST CONDITIONS	MIN	TYP	MAX	UNIT
DIVIDER CONTROL INPUT (DIV) CHARACTERISTICS					
V_{d3} 3-state input	Open		$0.5 \times V_{CC}$		V
V_{dIH} Input high voltage		$0.7 \times V_{CC}$			V
V_{dIL} Input low voltage				$0.2 \times V_{CC}$	V
I_{dIH} Input high current	$V_{CC} = 2.625\text{ V}, V_{IH} = 2.625\text{ V}$			30	μA
I_{dIL} Input low current	$V_{CC} = 2.625\text{ V}, V_{IL} = 0\text{ V}$			-30	μA
$R_{pull(DIV)}$ Input pullup or pulldown resistor			200		k Ω
DIFFERENTIAL INPUTS (INP, INN) CHARACTERISTICS					
f_{IN} Input frequency	Clock input			800	MHz
$V_{IN, DIFF}$ Differential input voltage peak-to-peak	$V_{ICM} = 1.25\text{ V}$	0.3		1.6	V_{PP}
V_{ICM} Input common-mode voltage range		1		$V_{CC} - 0.3$	V
R_{IN} Input termination	INP, INN to V_T , DC		70		Ω
I_{IH} Input high current	$V_{CC} = 2.625\text{ V}, V_{IH} = 2.625\text{ V}$			10	μA
I_{IL} Input low current	$V_{CC} = 2.625\text{ V}, V_{IL} = 0\text{ V}$			-10	μA
$\Delta V/\Delta T$ Input edge rate	20% to 80%	0.75			V/ns
C_{IN} Input capacitance			2.5		pF

Electrical Characteristics (continued)

 $V_{CC} = 2.375\text{ V to }2.625\text{ V}$ and $T_A = -40^\circ\text{C to }85^\circ\text{C}$ (unless otherwise noted)

PARAMETER		TEST CONDITIONS	MIN	TYP	MAX	UNIT
LVDS OUTPUT CHARACTERISTICS						
$ V_{OD} $	Differential output voltage magnitude	$V_{IN, DIFF, PP} = 0.3\text{ V},$ $R_L = 100\ \Omega$	250		450	mV
ΔV_{OD}	Change in differential output voltage magnitude		-15		15	mV
$V_{OC(SS)}$	Steady-state common-mode output voltage		1.1		1.375	V
$\Delta V_{OC(SS)}$	Steady-state common-mode output voltage	$V_{IN, DIFF, PP} = 0.6\text{ V},$ $R_L = 100\ \Omega$	-15		15	mV
I_{OS}	Short-circuit output current	$V_{OD} = 0\text{ V}$			± 24	mA
V_{OS}	Output AC common mode	$V_{IN, DIFF, PP} = 0.6\text{ V}, R_L = 100\ \Omega$		25	70	mV _{PP}
V_{ring}	Output overshoot and undershoot	Percentage of output amplitude V_{OD}			10%	
t_{PD}	Propagation delay	$V_{IN, DIFF, PP} = 0.3\text{ V}$		1.5	2.5	ns
$t_{SK, PP}$	Part-to-part skew				600	ps
$t_{SK, O}$	Output skew ⁽¹⁾				20	ps
$t_{SK, P}$	Pulse skew (with 50% duty cycle input)	Crossing-point-to-crossing-point distortion	-50		50	ps
t_{RJIT}	Random additive jitter (with 50% duty cycle input)	Edge speed 0.75 V/ns 10 kHz – 20 MHz			0.3	ps, RMS
t_R/t_F	Output rise/fall time	20% to 80%, 100 Ω , 5 pF	50		300	ps
I_{CCSTAT}	Static supply current	Outputs unterminated, $f = 0\text{ Hz}$		17	28	mA
I_{CC100}	Supply current	All outputs, $R_L = 100\ \Omega,$ $f = 100\text{ MHz}$		40	58	mA
I_{CC800}	Supply current	All outputs, $R_L = 100\ \Omega,$ $f = 800\text{ MHz}$		60	85	mA

(1) Undivided outputs only.

6.6 Timing Requirements

		MIN	NOM	MAX	UNIT
ADDITIVE PHASE NOISE FOR 100-MHZ CLOCK					
phn_{100}	Phase noise at 100-Hz offset		-132.9		dBc/Hz
phn_{1k}	Phase noise at 1-kHz offset		-138.8		dBc/Hz
phn_{10k}	Phase noise at 10-kHz offset		-147.4		dBc/Hz
phn_{100k}	Phase noise at 100-kHz offset		-153.6		dBc/Hz
phn_{1M}	Phase noise at 1-MHz offset		-155.2		dBc/Hz
phn_{10M}	Phase noise at 10-MHz offset		-156.2		dBc/Hz
phn_{20M}	Phase noise at 20-MHz offset		-156.6		dBc/Hz
t_{RJIT}	Random additive jitter from 10 kHz to 20 MHz		171		fs, RMS
ADDITIVE PHASE NOISE FOR 737.27-MHZ CLOCK					
phn_{100}	Phase noise at 100-Hz offset		-80.2		dBc/Hz
phn_{1k}	Phase noise at 1-kHz offset		-114.3		dBc/Hz
phn_{10k}	Phase noise at 10-kHz offset		-138		dBc/Hz
phn_{100k}	Phase noise at 100-kHz offset		-143.9		dBc/Hz
phn_{1M}	Phase noise at 1-MHz offset		-145.2		dBc/Hz
phn_{10M}	Phase noise at 10-MHz offset		-146.5		dBc/Hz
phn_{20M}	Phase noise at 20-MHz offset		-146.6		dBc/Hz
t_{RJIT}	Random additive jitter from 10 kHz to 20 MHz		65		fs, RMS

6.7 Typical Characteristics

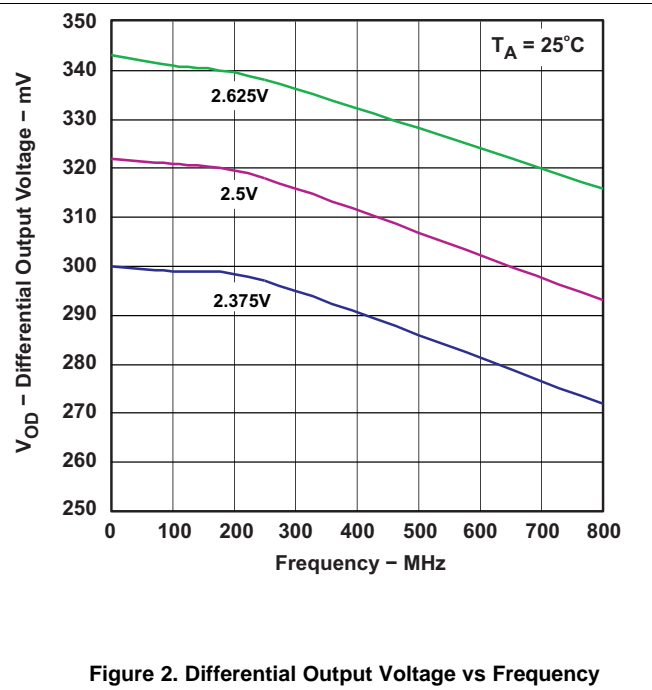
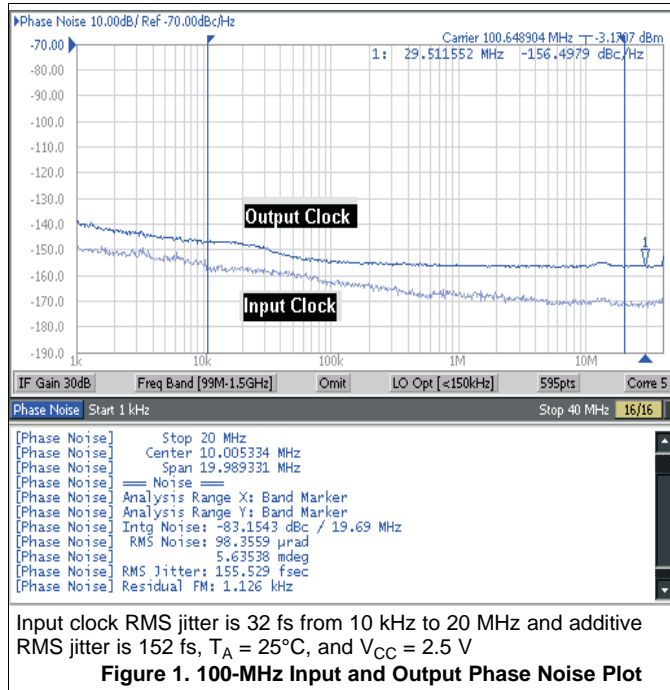

7 Parameter Measurement Information

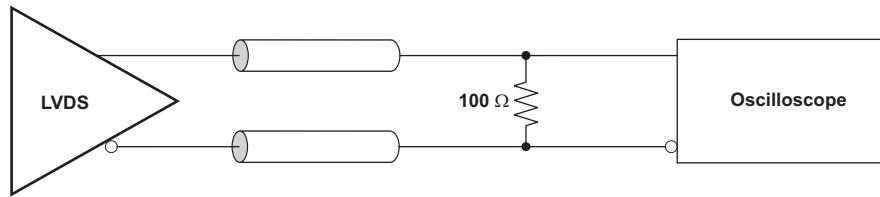

Figure 3. LVDS Output DC Configuration During Device Test

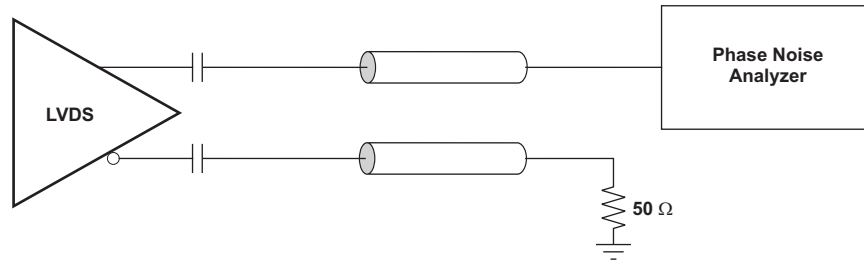

Figure 4. LVDS Output AC Configuration During Device Test

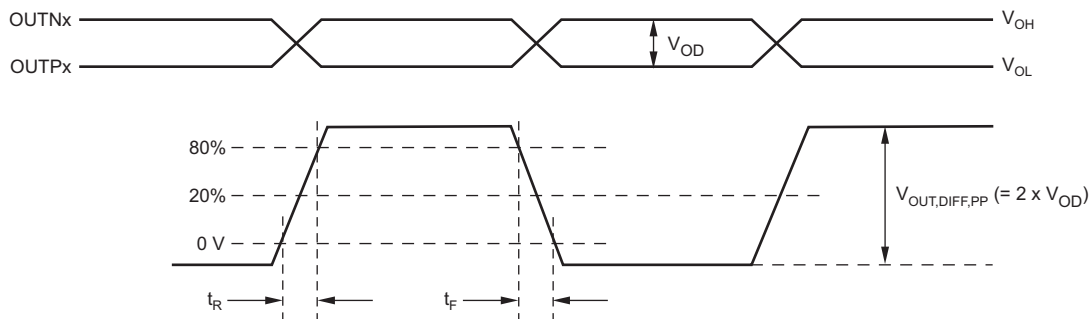
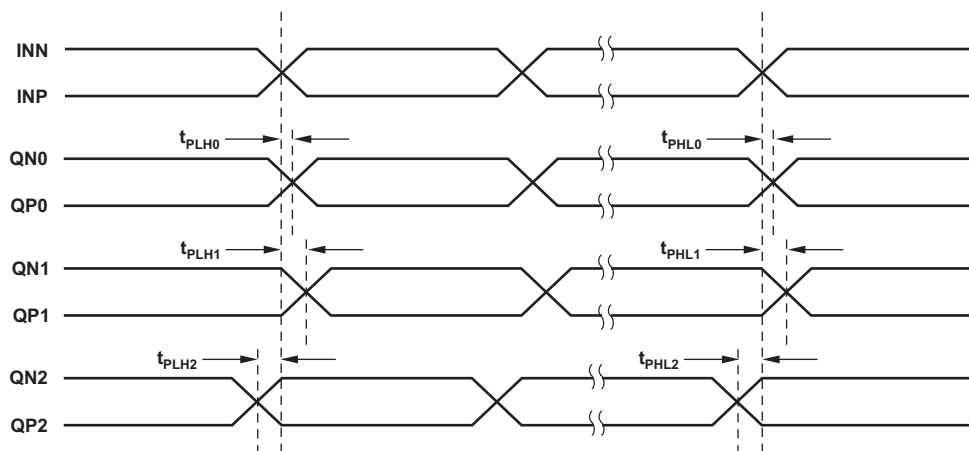

Figure 5. Output Voltage and Rise/Fall Time



- (1) Output skew is calculated as the greater of the following: As the difference between the fastest and the slowest t_{PLHn} or the difference between the fastest and the slowest t_{PHLn} ($n = 0, 1, 2$).
- (2) Part-to-part skew is calculated as the greater of the following: As the difference between the fastest and the slowest t_{PLHn} or the difference between the fastest and the slowest t_{PHLn} across multiple devices ($n = 0, 1, 2$).

Figure 6. Output and Part-to-Part Skew

Parameter Measurement Information (continued)

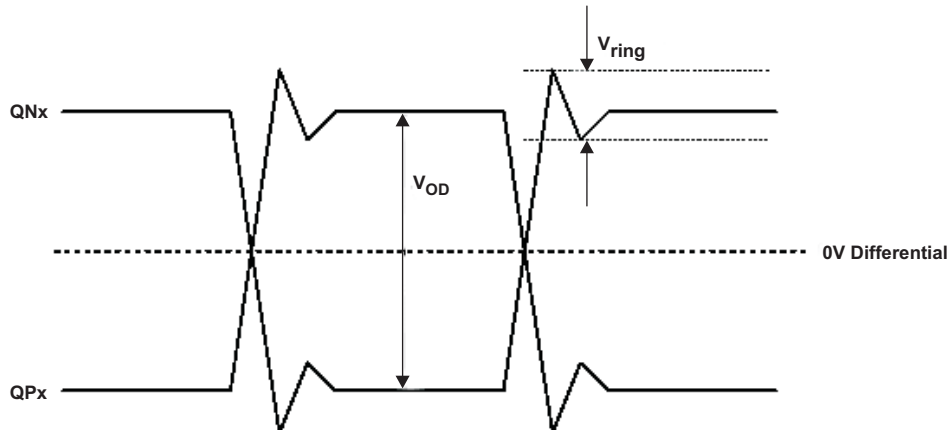

Figure 7. Output Overshoot and Undershoot

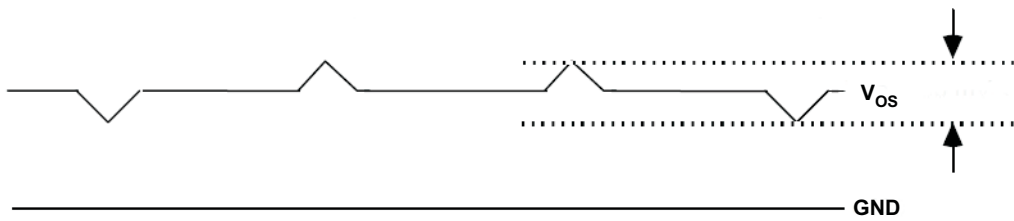

Figure 8. Output AC Common Mode

8 Detailed Description

8.1 Overview

The CDCLVD1213 LVDS drivers use CMOS transistors to control the output current. Therefore, proper biasing and termination are required to ensure correct operation of the device and to maximize signal integrity.

The proper LVDS termination for signal integrity over two 50-Ω lines is 100 Ω between the outputs on the receiver end. Either DC-coupled termination or AC-coupled termination can be used for LVDS outputs. TI recommends placing a termination resistor close to the receiver. If the receiver is internally biased to a voltage different than the output common-mode voltage of the CDCLVD1213, AC-coupling must be used. If the LVDS receiver has internal 100-Ω termination, external termination must be omitted.

8.2 Functional Block Diagram

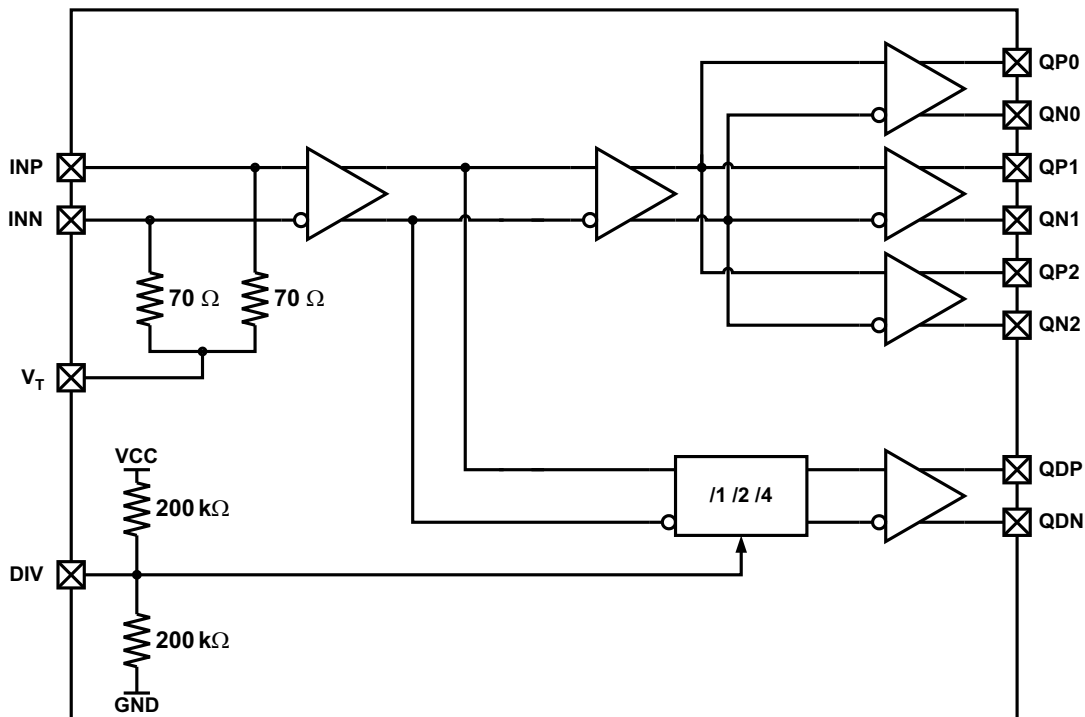

Copyright © 2016, Texas Instruments Incorporated

8.3 Feature Description

The CDCLVD1213 is a low additive jitter LVDS fan-out buffer that can generate four copies of an LVPECL, LVDS, or CML input, one of which can be frequency divided by a factor of 1, 2, or 4. The CDCLVD1213 can accept reference clock frequencies up to 800 MHz while providing low output skew.

8.4 Device Functional Modes

The divider on output QD can be configured to divide the input frequency by a factor 1, 2, or 4 through the control pin (see Table 1). Unused outputs can be left floating to reduce overall component cost. Both AC- and DC-coupling schemes can be used with the CDCLVD1213 to provide greater system flexibility.

Table 1. Divider Selection Table

DIV	DIVIDER RATIO
0	/1
open	/2
1	/4

8.4.1 LVDS Output Termination

Unused outputs can be left open without connecting any traces to the output pins.

The CDCLVD1213 can be connected to LVDS receiver inputs with DC- and AC-coupling as shown in [Figure 9](#) and [Figure 10](#) (respectively).

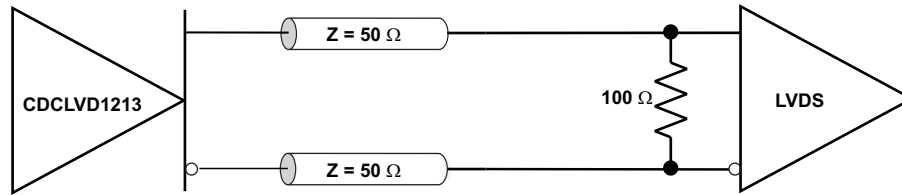

Figure 9. Output DC Termination

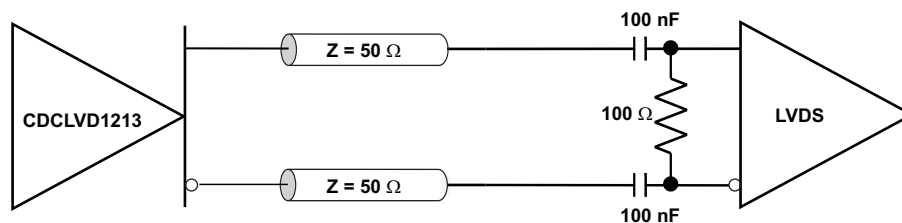

Figure 10. Output AC Termination (With the Receiver Internally Biased)

8.4.2 Input Termination

The CDCLVD1213 input has an internal 140-Ω termination and can be interfaced with LVDS, LVPECL, or CML drivers. An external 350-Ω resistor (in parallel with the internal 140-Ω termination) is required to interface with a 50-Ω transmission line.

LVDS drivers can be connected to CDCLVD1213 inputs with DC- and AC-coupling as shown in [Figure 11](#) and [Figure 12](#) (respectively). With AC coupling, an external bias voltage ($V_{CC}/2$) must be provided to the V_T pin.

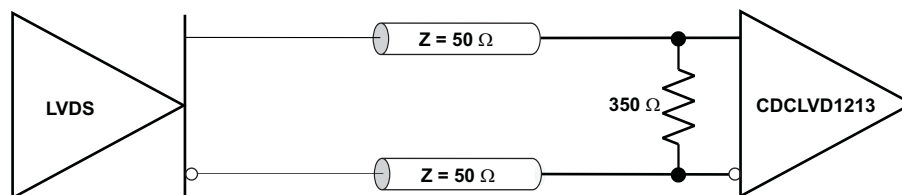

Figure 11. LVDS Clock Driver Connected to CDCLVD1213 Input (DC-Coupled)

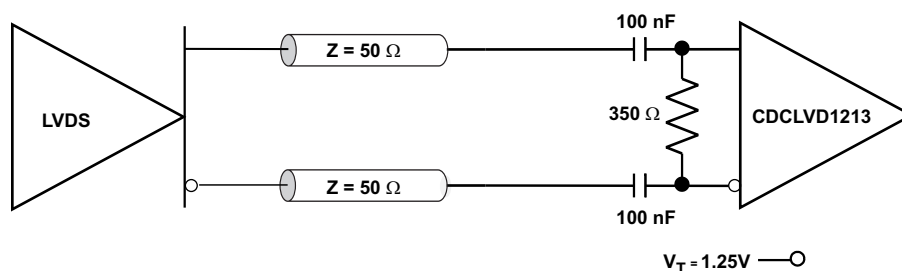

Figure 12. LVDS Clock Driver Connected to CDCLVD1213 Input (AC-Coupled)

[Figure 13](#) illustrates how to connect a CML input to the CDCLVD1213 input buffer. The input does not have internal biasing, so external biasing ($V_{CC}/2$ to V_T) is required for AC coupling. If the CML output swing is $>1.6 V_{PP}$, then signal swing must be reduced to meet $V_{IN, DIF, PP} \leq 1.6 V_{PP}$.

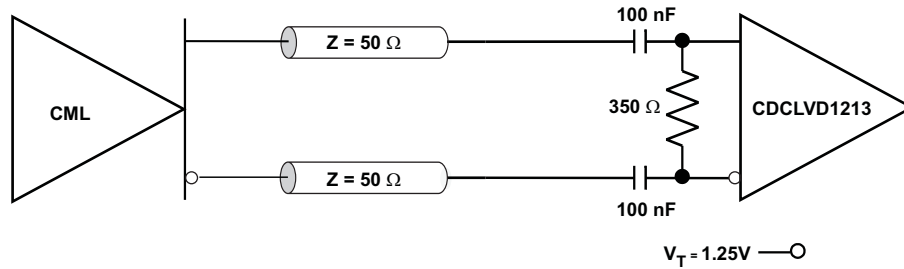

Figure 13. CML Clock Driver Connected to CDCLVD1213 Input

Figure 14 illustrates how to connect an LVPECL input to the CDCLVD1213 input buffer. The input does not have internal biasing, so external biasing ($V_{CC}/2$ to V_T) is required for AC coupling. The series resistors are required to reduce the LVPECL signal swing if the signal swing is >1.6 Vpp.

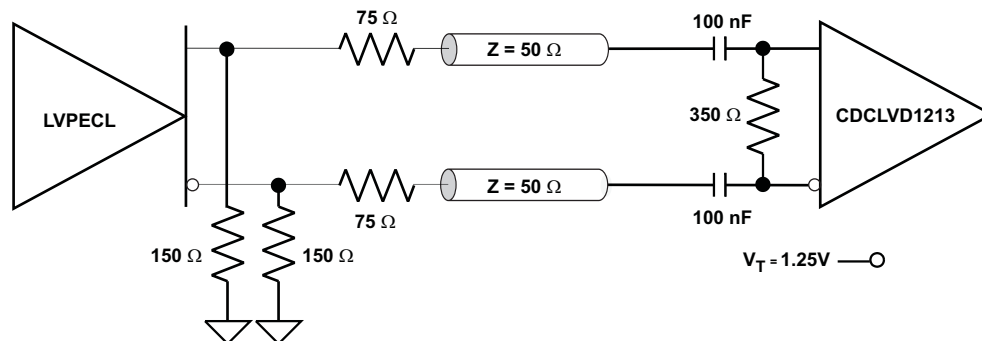

Figure 14. LVPECL Clock Driver Connected to CDCLVD1213 Input

9 Application and Implementation

NOTE

Information in the following applications sections is not part of the TI component specification, and TI does not warrant its accuracy or completeness. TI's customers are responsible for determining suitability of components for their purposes. Customers should validate and test their design implementation to confirm system functionality.

9.1 Application Information

The CDCLVD1213 is a low additive jitter universal to LVDS fan-out buffer with an integrated frequency divider on one output. The small package, low output skew, and low additive jitter make for a flexible device in demanding applications.

9.2 Typical Application

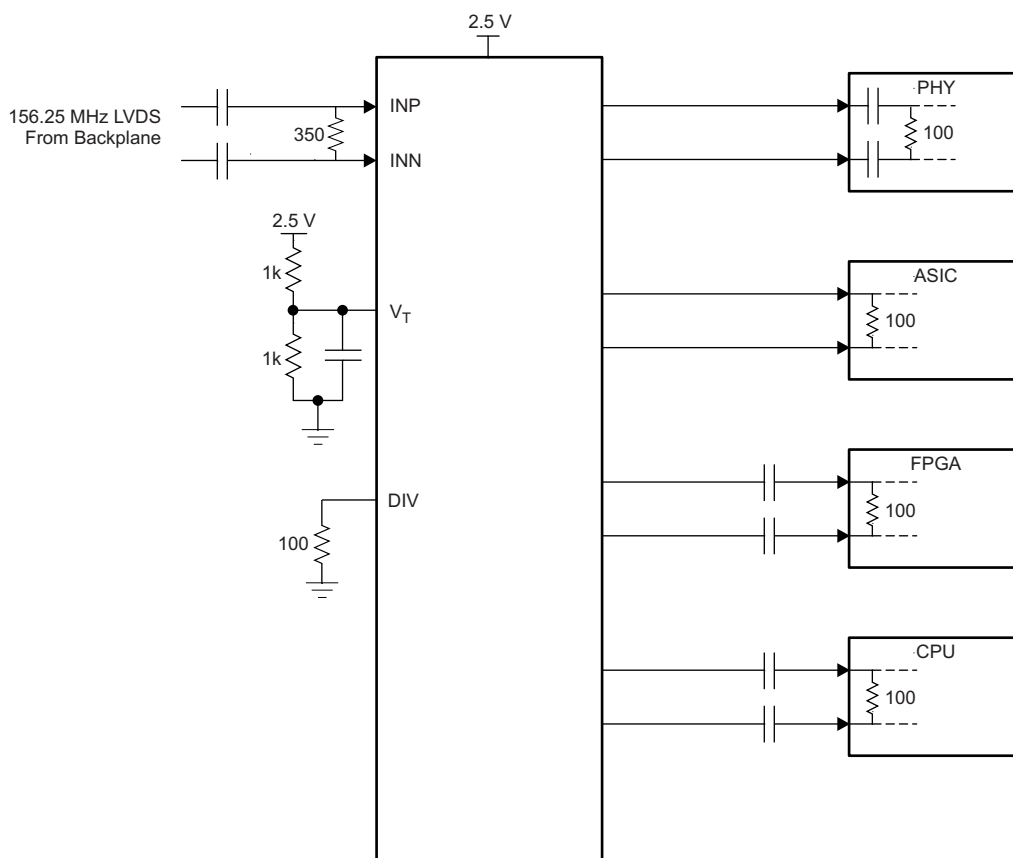

Copyright © 2016, Texas Instruments Incorporated

Figure 15. Fan-Out Buffer for Line Card Application

Typical Application (continued)

9.2.1 Design Requirements

The CDCLVD1213 shown in Figure 15 is configured with a 156.25-MHz LVDS clock from the backplane as its input frequency. The LVDS clock is AC-coupled. A resistor divider (and a 0.1- μ F capacitor to reduce noise) is used to set the bias voltage correctly at the V_T pin. The configuration example is driving 4 LVDS receivers in a line card application with the following properties:

- The PHY device is capable of DC-coupling with an LVDS driver such as the CDCLVD1213. This PHY device features internal termination so no additional components are required for proper operation.
- The ASIC LVDS receiver features internal termination and operates at the same common-mode voltage as the CDCLVD1213. Again, no additional components are required.
- The FPGA requires external AC-coupling, but has internal termination. 0.1- μ F capacitors are placed to provide AC-coupling.
- The CPU on output QD is internally terminated, and requires only external AC-coupling capacitors. The DIV pin is pulled to ground with a 100- Ω resistor to set the frequency divider to 1 so that the CPU clock frequency is also 156.25 MHz.

9.2.2 Detailed Design Procedure

See [Input Termination](#) for proper input terminations, dependent on single-ended or differential inputs.

See [LVDS Output Termination](#) for output termination schemes depending on the receiver application.

Unused outputs can be left floating.

In this example, the PHY, ASIC, and FPGA or CPU require different schemes. Power supply filtering and bypassing is critical for low-noise applications.

See [Power Supply Recommendations](#) for recommended filtering techniques. A reference layout is provided in [Low-Additive Jitter, Four-LVDS-Outputs Clock Buffer With Divider EVM](#) (SCAU044).

9.2.3 Application Curves

The CDCLVD12xx's low additive noise is shown in this line card application. The low noise 156.25-MHz source with 67-fs RMS jitter drives the CDCLVD12xx, resulting in 80-fs RMS when integrated from 12 kHz to 20 MHz. The resultant additive jitter is a low 44-fs RMS for this configuration.

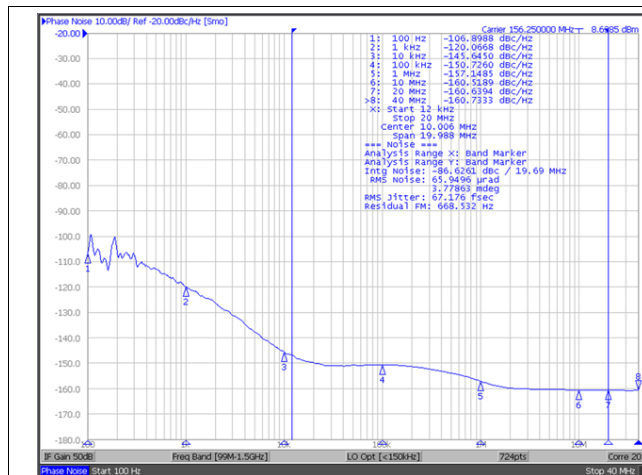

Reference signal is low-noise Rohde and Schwarz SMA100A

Figure 16. CDCLVD12xx Reference Phase Noise, 67-fs RMS (12 kHz to 20 MHz)

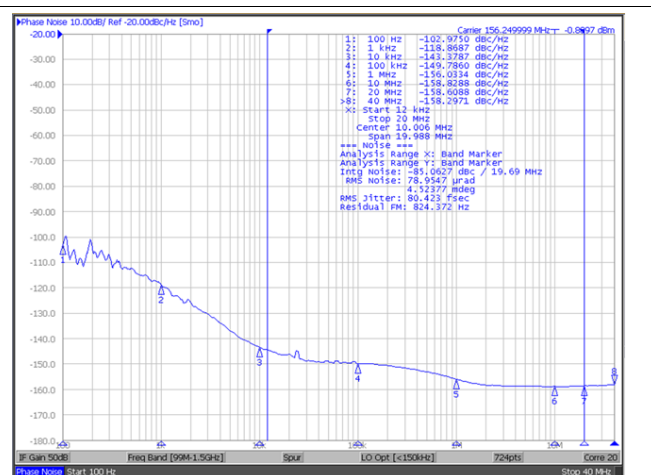

Figure 17. CDCLVD12xx Output Phase Noise, 80-fs RMS (12 kHz to 20 MHz)

10 Power Supply Recommendations

High-performance clock buffers are sensitive to noise on the power supply, which can dramatically increase the additive jitter of the buffer. Thus, it is essential to reduce noise from the system power supply, especially when jitter or phase noise is critical to applications.

Filter capacitors are used to eliminate the low-frequency noise from the power supply, where the bypass capacitors provide the low impedance path for high-frequency noise and guard the power-supply system against the induced fluctuations. These bypass capacitors also provide instantaneous current surges as required by the device and must have low equivalent series resistance (ESR). To properly use the bypass capacitors, they must be placed close to the power-supply pins and laid out with short loops to minimize inductance. TI recommends adding as many high-frequency (for example, 0.1- μF) bypass capacitors as there are supply pins in the package. TI recommends, but does not require, inserting a ferrite bead between the board power supply and the chip power supply that isolates the high-frequency switching noises generated by the clock driver; these beads prevent the switching noise from leaking into the board supply. Choose an appropriate ferrite bead with low DC-resistance because it is imperative to provide adequate isolation between the board supply and the chip supply, as well as to maintain a voltage at the supply pins that is greater than the minimum voltage required for proper operation.

Figure 18 shows this recommended power-supply decoupling method.

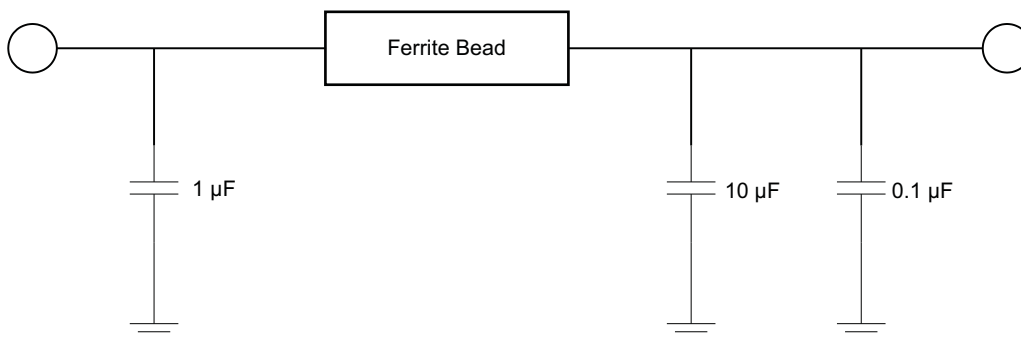

Figure 18. Power-Supply Decoupling

11 Layout

11.1 Layout Guidelines

For reliability and performance reasons, the die temperature must be limited to a maximum of 125°C.

The device package has an exposed pad that provides the primary heat removal path to the printed-circuit board (PCB). To maximize the heat dissipation from the package, a thermal landing pattern including multiple vias to a ground plane must be incorporated into the PCB within the footprint of the package. The thermal pad must be soldered down to ensure adequate heat conduction to of the package. Figure 19 shows a recommended land and via pattern.

11.2 Layout Example

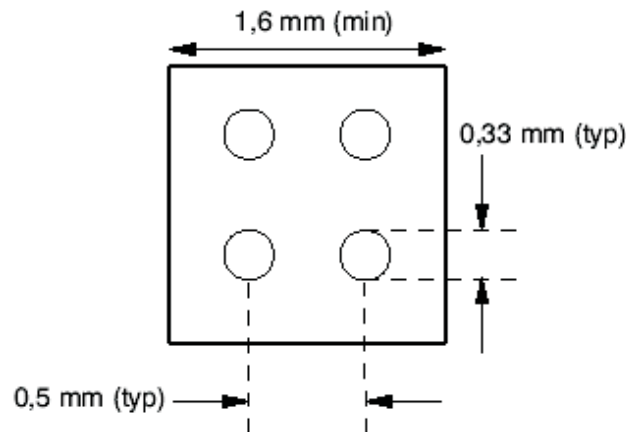

Figure 19. Recommended PCB Layout

11.3 Thermal Considerations

The CDCLVD1213 supports high temperatures on the printed-circuit board (PCB) measured at the thermal pad. The system designer must ensure that the maximum junction temperature is not exceeded. Ψ_{JB} can allow the system designer to measure the board temperature with a fine gauge thermocouple and back calculate the junction temperature using Equation 1. Note that Ψ_{JB} is close to $R_{\theta JB}$ as 75% to 95% of a device's heat is dissipated by the PCB.

$$T_J = T_{PCB} + (\Psi_{JB} \times \text{Power}) \quad (1)$$

Example:

Calculation of the junction-lead temperature with a 4-layer JEDEC test board using four thermal vias:

$$T_{PCB} = 105^\circ\text{C}$$

$$\Psi_{JB} = 19.4^\circ\text{C/W}$$

$$\text{Power}_{\text{inclTerm}} = I_{\text{max}} \times V_{\text{max}} = 85 \text{ mA} \times 2.625 \text{ V} = 223 \text{ mW} \text{ (maximum power consumption including termination resistors)}$$

$$\text{Power}_{\text{exclTerm}} = 215 \text{ mW} \text{ (maximum power consumption excluding termination resistors, see } \textit{Power Consumption of LVPECL and LVDS} \text{ (SLYT127) for further details)}$$

$$\Delta T_J = \Psi_{JB} \times \text{Power}_{\text{exclTerm}} = 19.4^\circ\text{C/W} \times 215 \text{ mW} = 4.17^\circ\text{C}$$

$$T_J = \Delta T_J + T_{\text{Chassis}} = 4.17^\circ\text{C} + 105^\circ\text{C} = 109.17^\circ\text{C} \text{ (maximum junction temperature of } 125^\circ\text{C} \text{ is not violated)}$$

Further information can be found at [Semiconductor and IC Package Thermal Metrics](#) (SPRA953) and [Using Thermal Calculation Tools for Analog Components](#) (SLUA566).

12 Device and Documentation Support

12.1 Documentation Support

12.1.1 Related Documentation

For related documentation see the following:

- [Low-Additive Jitter, Four-LVDS-Outputs Clock Buffer With Divider EVM](#) (SCAU044)
- [Power Consumption of LVPECL and LVDS](#) (SLYT127)
- [Semiconductor and IC Package Thermal Metrics](#) (SPRA953)
- [Using Thermal Calculation Tools for Analog Components](#) (SLUA566)

12.2 Receiving Notification of Documentation Updates

To receive notification of documentation updates, navigate to the device product folder on ti.com. In the upper right corner, click on *Alert me* to register and receive a weekly digest of any product information that has changed. For change details, review the revision history included in any revised document.

12.3 Community Resources

The following links connect to TI community resources. Linked contents are provided "AS IS" by the respective contributors. They do not constitute TI specifications and do not necessarily reflect TI's views; see TI's [Terms of Use](#).

TI E2E™ Online Community *TI's Engineer-to-Engineer (E2E) Community*. Created to foster collaboration among engineers. At e2e.ti.com, you can ask questions, share knowledge, explore ideas and help solve problems with fellow engineers.

Design Support *TI's Design Support* Quickly find helpful E2E forums along with design support tools and contact information for technical support.

12.4 Trademarks

E2E is a trademark of Texas Instruments.

12.5 Electrostatic Discharge Caution



These devices have limited built-in ESD protection. The leads should be shorted together or the device placed in conductive foam during storage or handling to prevent electrostatic damage to the MOS gates.

12.6 Glossary

[SLYZ022](#) — *TI Glossary*.

This glossary lists and explains terms, acronyms, and definitions.

13 Mechanical, Packaging, and Orderable Information

The following pages include mechanical, packaging, and orderable information. This information is the most current data available for the designated devices. This data is subject to change without notice and revision of this document. For browser-based versions of this data sheet, refer to the left-hand navigation.

PACKAGING INFORMATION

Orderable Device	Status (1)	Package Type	Package Drawing	Pins	Package Qty	Eco Plan (2)	Lead finish/ Ball material (6)	MSL Peak Temp (3)	Op Temp (°C)	Device Marking (4/5)	Samples
CDCLVD1213RGTR	ACTIVE	VQFN	RGT	16	3000	RoHS & Green	NIPDAU	Level-2-260C-1 YEAR	-40 to 85	D1213	Samples
CDCLVD1213RGTT	ACTIVE	VQFN	RGT	16	250	RoHS & Green	NIPDAU	Level-2-260C-1 YEAR	-40 to 85	D1213	Samples

(1) The marketing status values are defined as follows:

ACTIVE: Product device recommended for new designs.

LIFEBUY: TI has announced that the device will be discontinued, and a lifetime-buy period is in effect.

NRND: Not recommended for new designs. Device is in production to support existing customers, but TI does not recommend using this part in a new design.

PREVIEW: Device has been announced but is not in production. Samples may or may not be available.

OBsolete: TI has discontinued the production of the device.

(2) **RoHS:** TI defines "RoHS" to mean semiconductor products that are compliant with the current EU RoHS requirements for all 10 RoHS substances, including the requirement that RoHS substance do not exceed 0.1% by weight in homogeneous materials. Where designed to be soldered at high temperatures, "RoHS" products are suitable for use in specified lead-free processes. TI may reference these types of products as "Pb-Free".

RoHS Exempt: TI defines "RoHS Exempt" to mean products that contain lead but are compliant with EU RoHS pursuant to a specific EU RoHS exemption.

Green: TI defines "Green" to mean the content of Chlorine (Cl) and Bromine (Br) based flame retardants meet JS709B low halogen requirements of <=1000ppm threshold. Antimony trioxide based flame retardants must also meet the <=1000ppm threshold requirement.

(3) MSL, Peak Temp. - The Moisture Sensitivity Level rating according to the JEDEC industry standard classifications, and peak solder temperature.

(4) There may be additional marking, which relates to the logo, the lot trace code information, or the environmental category on the device.

(5) Multiple Device Markings will be inside parentheses. Only one Device Marking contained in parentheses and separated by a "~" will appear on a device. If a line is indented then it is a continuation of the previous line and the two combined represent the entire Device Marking for that device.

(6) Lead finish/Ball material - Orderable Devices may have multiple material finish options. Finish options are separated by a vertical ruled line. Lead finish/Ball material values may wrap to two lines if the finish value exceeds the maximum column width.

Important Information and Disclaimer:The information provided on this page represents TI's knowledge and belief as of the date that it is provided. TI bases its knowledge and belief on information provided by third parties, and makes no representation or warranty as to the accuracy of such information. Efforts are underway to better integrate information from third parties. TI has taken and continues to take reasonable steps to provide representative and accurate information but may not have conducted destructive testing or chemical analysis on incoming materials and chemicals. TI and TI suppliers consider certain information to be proprietary, and thus CAS numbers and other limited information may not be available for release.

In no event shall TI's liability arising out of such information exceed the total purchase price of the TI part(s) at issue in this document sold by TI to Customer on an annual basis.

TAPE AND REEL INFORMATION

QUADRANT ASSIGNMENTS FOR PIN 1 ORIENTATION IN TAPE

*All dimensions are nominal

Device	Package Type	Package Drawing	Pins	SPQ	Reel Diameter (mm)	Reel Width W1 (mm)	A0 (mm)	B0 (mm)	K0 (mm)	P1 (mm)	W (mm)	Pin1 Quadrant
CDCLVD1213RGTR	VQFN	RGT	16	3000	330.0	12.4	3.3	3.3	1.1	8.0	12.0	Q2

TAPE AND REEL BOX DIMENSIONS

*All dimensions are nominal

Device	Package Type	Package Drawing	Pins	SPQ	Length (mm)	Width (mm)	Height (mm)
CDCLVD1213RGTR	VQFN	RGT	16	3000	350.0	350.0	43.0

RGT 16

GENERIC PACKAGE VIEW

VQFN - 1 mm max height

PLASTIC QUAD FLATPACK - NO LEAD

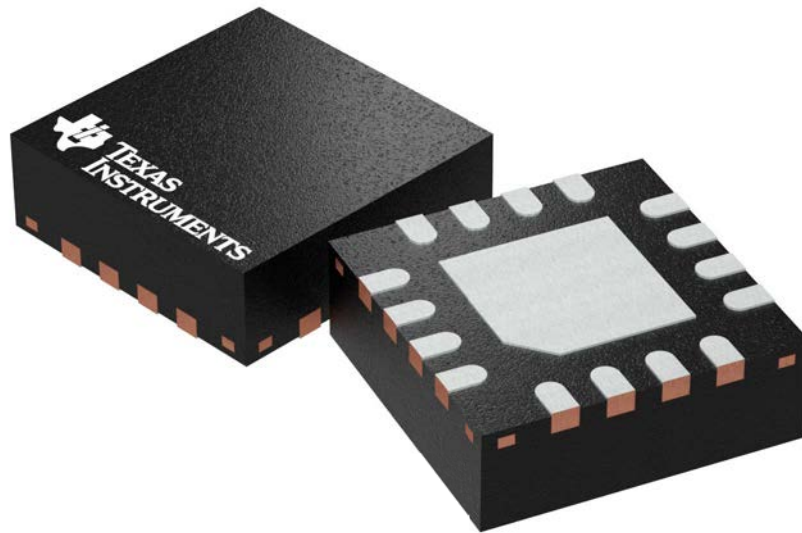

Images above are just a representation of the package family, actual package may vary.
Refer to the product data sheet for package details.

4203495/1

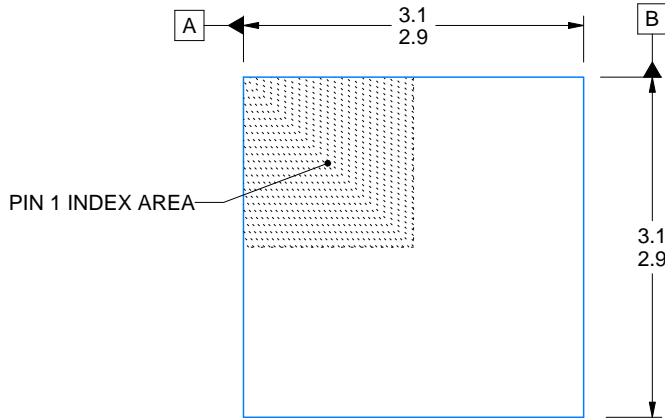
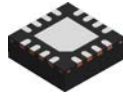

SIDE WALL METAL THICKNESS DIM A	
OPTION 1	OPTION 2
0.1	0.2

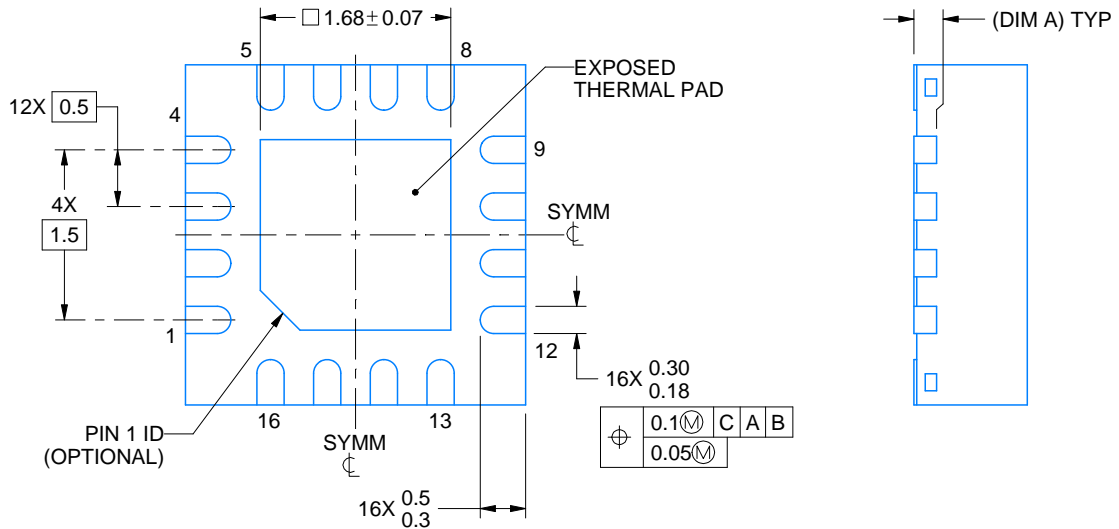
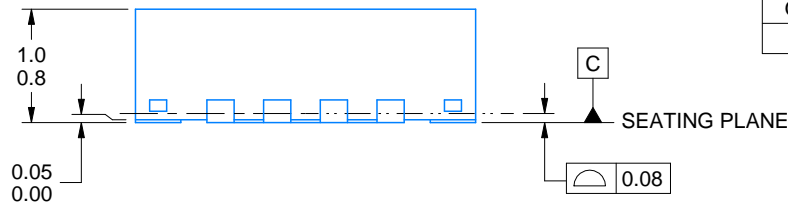

4222419/D 04/2022

NOTES:

1. All linear dimensions are in millimeters. Any dimensions in parenthesis are for reference only. Dimensioning and tolerancing per ASME Y14.5M.
2. This drawing is subject to change without notice.
3. The package thermal pad must be soldered to the printed circuit board for thermal and mechanical performance.

EXAMPLE STENCIL DESIGN

RGT0016C

VQFN - 1 mm max height

PLASTIC QUAD FLATPACK - NO LEAD

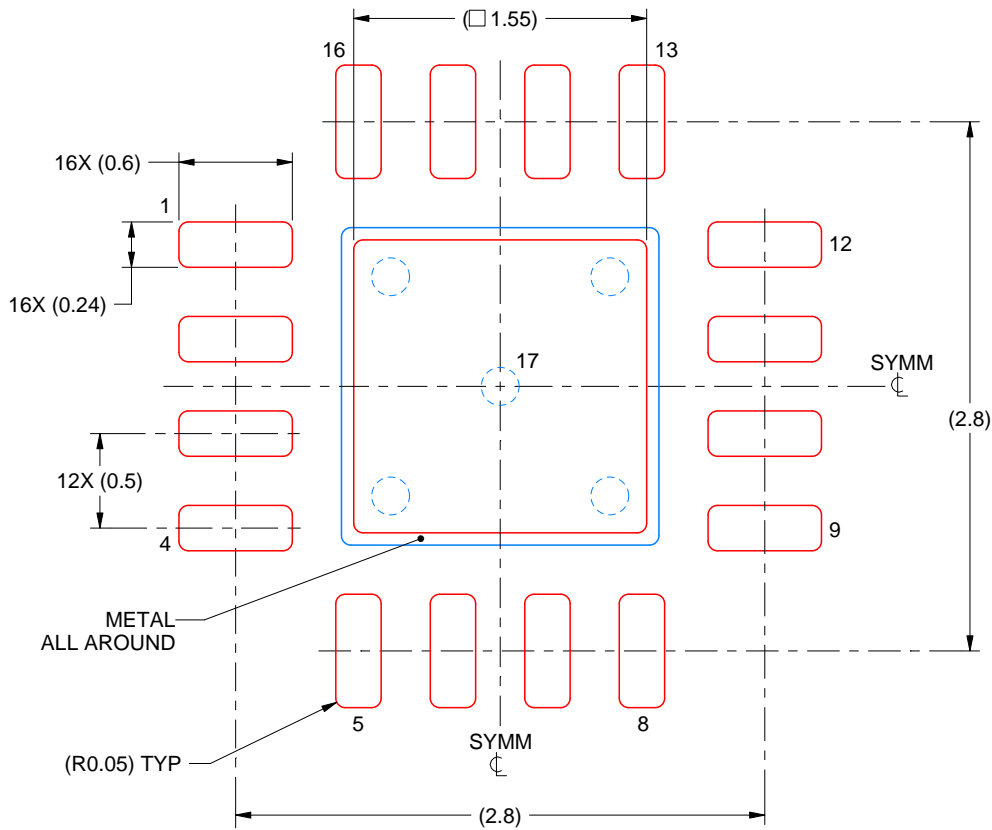

SOLDER PASTE EXAMPLE
BASED ON 0.125 mm THICK STENCIL

EXPOSED PAD 17:
85% PRINTED SOLDER COVERAGE BY AREA UNDER PACKAGE
SCALE:25X

4222419/D 04/2022

NOTES: (continued)

6. Laser cutting apertures with trapezoidal walls and rounded corners may offer better paste release. IPC-7525 may have alternate design recommendations.

IMPORTANT NOTICE AND DISCLAIMER

TI PROVIDES TECHNICAL AND RELIABILITY DATA (INCLUDING DATA SHEETS), DESIGN RESOURCES (INCLUDING REFERENCE DESIGNS), APPLICATION OR OTHER DESIGN ADVICE, WEB TOOLS, SAFETY INFORMATION, AND OTHER RESOURCES "AS IS" AND WITH ALL FAULTS, AND DISCLAIMS ALL WARRANTIES, EXPRESS AND IMPLIED, INCLUDING WITHOUT LIMITATION ANY IMPLIED WARRANTIES OF MERCHANTABILITY, FITNESS FOR A PARTICULAR PURPOSE OR NON-INFRINGEMENT OF THIRD PARTY INTELLECTUAL PROPERTY RIGHTS.

These resources are intended for skilled developers designing with TI products. You are solely responsible for (1) selecting the appropriate TI products for your application, (2) designing, validating and testing your application, and (3) ensuring your application meets applicable standards, and any other safety, security, regulatory or other requirements.

These resources are subject to change without notice. TI grants you permission to use these resources only for development of an application that uses the TI products described in the resource. Other reproduction and display of these resources is prohibited. No license is granted to any other TI intellectual property right or to any third party intellectual property right. TI disclaims responsibility for, and you will fully indemnify TI and its representatives against, any claims, damages, costs, losses, and liabilities arising out of your use of these resources.

TI's products are provided subject to [TI's Terms of Sale](#) or other applicable terms available either on [ti.com](https://www.ti.com) or provided in conjunction with such TI products. TI's provision of these resources does not expand or otherwise alter TI's applicable warranties or warranty disclaimers for TI products.

TI objects to and rejects any additional or different terms you may have proposed.

Mailing Address: Texas Instruments, Post Office Box 655303, Dallas, Texas 75265
Copyright © 2023, Texas Instruments Incorporated

Looking for pricing, stock, or lifecycle information?

Click below to explore more details on WIN SOURCE:

 [View CDCLVD1213RGTT on WIN SOURCE](#)

 [Texas Instruments](#) Information

Optimize Your Supply Chain with WIN SOURCE Solutions

-  Global Sourcing Solution
-  Obsolete Management
-  Cost Control Management
-  Shortage Management
-  Alternative Solution
-  Excess Inventory Management