



THE DATASHEET OF AM26LV31ESDREP



LOW-VOLTAGE HIGH-SPEED QUADRUPLE DIFFERENTIAL LINE DRIVER WITH ± 15 -kV IEC ESD PROTECTION

FEATURES

- Meets or Exceeds Standards TIA/EIA-422-B and ITU Recommendation V.11
- Operates From a Single 3.3-V Power Supply
- ESD Protection for RS422 Bus Pins
 - ± 15 -kV Human-Body Model (HBM)
 - ± 8 -kV IEC61000-4-2, Contact Discharge
 - ± 15 -kV IEC61000-4-2, Air-Gap Discharge
- Switching Rates up to 32 MHz
- Propagation Delay Time . . . 8 ns Typ
- Pulse Skew Time . . . 500 ps Typ
- High Output-Drive Current . . . ± 30 mA
- Controlled Rise and Fall Times . . . 5 ns Typ
- Differential Output Voltage With 100- Ω Load . . . 2.6 V Typ
- Accepts 5-V Logic Inputs With 3.3-V Supply
- I_{off} Supports Partial-Power-Down Mode Operation
- Driver Output Short-Protection Circuit
- Glitch-Free Power-Up/Power-Down Protection

SUPPORTS DEFENSE, AEROSPACE, AND MEDICAL APPLICATIONS

- Controlled Baseline
- One Assembly/Test Site
- One Fabrication Site
- Available in Extended ($-55^{\circ}\text{C}/105^{\circ}\text{C}$) Temperature Range⁽¹⁾
- Extended Product Life Cycle
- Extended Product-Change Notification
- Product Traceability

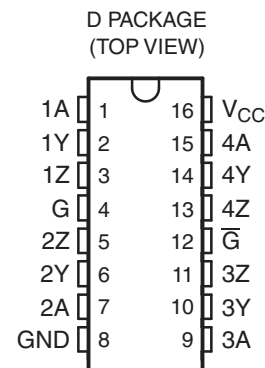

(1) Additional temperature ranges are available – contact factory

DESCRIPTION/ORDERING INFORMATION

The AM26LV31E is a quadruple differential line driver with 3-state outputs. This driver has ± 15 -kV ESD (HBM and IEC61000-4-2, Air-Gap Discharge) and ± 8 -kV ESD (IEC61000-4-2, Contact Discharge) protection. This device is designed to meet TIA/EIA-422-B and ITU Recommendation V.11 drivers with reduced supply voltage.

The device is optimized for balanced-bus transmission at switching rates up to 32 MHz. The outputs have high current capability for driving balanced lines, such as twisted-pair transmission lines, and provide a high impedance in the power-off condition.

The AM26LV31ES is characterized for operation from -55°C to 105°C .

ORDERING INFORMATION

T_A	PACKAGE ⁽¹⁾⁽²⁾		ORDERABLE PART NUMBER	TOP-SIDE MARKING
-55°C to 105°C	SOIC – D	Tape and reel	AM26LV31ESDREP	A26LV31ESP

(1) Package drawings, thermal data, and symbolization are available at www.ti.com/packaging.

(2) For the most current package and ordering information, see the Package Option Addendum at the end of this document, or see the TI website at www.ti.com.



Please be aware that an important notice concerning availability, standard warranty, and use in critical applications of Texas Instruments semiconductor products and disclaimers thereto appears at the end of this data sheet.

FUNCTION TABLE⁽¹⁾

INPUT A	ENABLES		OUTPUTS	
	G	\bar{G}	Y	Z
H	H	X	H	L
L	H	X	L	H
H	X	L	H	L
L	X	L	L	H
X	L	H	Z	Z

(1) H = high level, L = low level, X = irrelevant, Z = high impedance (off)

LOGIC DIAGRAM

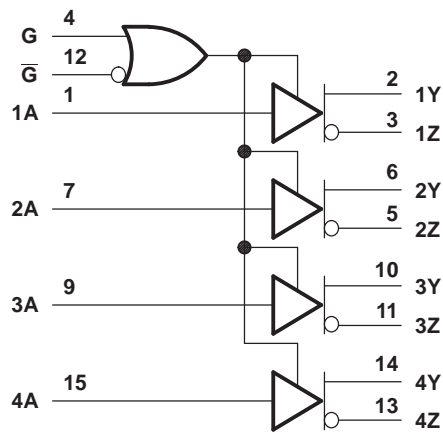

SCHEMATIC

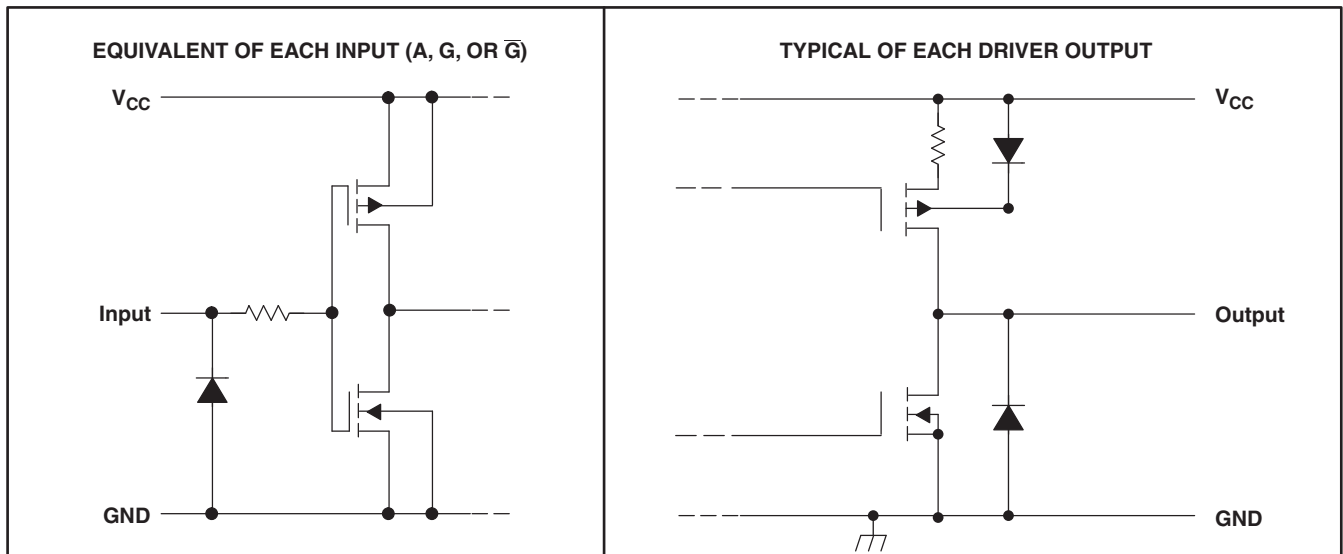

ABSOLUTE MAXIMUM RATINGS⁽¹⁾

over operating free-air temperature range (unless otherwise noted)

		MIN	MAX	UNIT
V_{CC}	Supply voltage range ⁽²⁾	-0.5	6	V
V_I	Input voltage range	-0.5	6	V
V_O	Output voltage range	-0.5	6	V
I_{IK}	Input clamp current	$V_I < 0$		mA
I_{OK}	Output clamp current	$V_O < 0$		mA
I_O	Continuous output current		±150	mA
	Continuous current through V_{CC} or GND		±200	mA
T_J	Operating virtual junction temperature		150	°C
θ_{JA}	Package thermal impedance ⁽³⁾⁽⁴⁾		73	°C/W
T_A	Operating free-air temperature range	-55	105	°C
T_{stg}	Storage temperature range	-65	150	°C

- (1) Stresses beyond those listed under "absolute maximum ratings" may cause permanent damage to the device. These are stress ratings only, and functional operation of the device at these or any other conditions beyond those indicated under "recommended operating conditions" is not implied. Exposure to absolute-maximum-rated conditions for extended periods may affect device reliability.
- (2) All voltage values except differential input voltage are with respect to the network GND.
- (3) Maximum power dissipation is a function of $T_{J(max)}$, θ_{JA} , and T_A . The maximum allowable power dissipation at any allowable ambient temperature is $P_D = (T_{J(max)} - T_A)/\theta_{JA}$. Selecting the maximum of 150°C can affect reliability.
- (4) The package thermal impedance is calculated in accordance with JESD 51-7.

RECOMMENDED OPERATING CONDITIONS

		MIN	NOM	MAX	UNIT
V_{CC}	Supply voltage	3	3.3	3.6	V
V_I	Input voltage	0		5.5	V
V_{IH}	High-level input voltage	2			V
V_{IL}	Low-level input voltage			0.8	V
I_{OH}	High-level output current			-30	mA
I_{OL}	Low-level output current			30	mA
T_A	Operating free-air temperature	-55		105	°C

ELECTRICAL CHARACTERISTICS

over recommended ranges of supply voltage and operating free-air temperature (unless otherwise noted)

PARAMETER	TEST CONDITIONS	MIN	TYP ⁽¹⁾	MAX	UNIT
V_{OH}	High-level output voltage	$V_{IH} = 2\text{ V}, V_{IL} = 0.8\text{ V}, I_{OH} = -20\text{ mA}$			V
V_{OL}	Low-level output voltage	$V_{IH} = 2\text{ V}, V_{IL} = 0.8\text{ V}, I_{OL} = 20\text{ mA}$			V
$ V_{OD1} $	Differential output voltage	$I_O = 0\text{ mA}$			V
$ V_{OD2} $	Differential output voltage	$R_L = 100\ \Omega$ (see Figure 1) ⁽²⁾			V
$\Delta V_{OD} $	Change in magnitude of differential output voltage	$R_L = 100\ \Omega$ (see Figure 1) ⁽²⁾			V
V_{OC}	Common-mode output voltage	$R_L = 100\ \Omega$ (see Figure 1) ⁽²⁾			V
$\Delta V_{OC} $	Change in magnitude of common-mode output voltage	$R_L = 100\ \Omega$ (see Figure 1) ⁽²⁾			V
$I_{O(OFF)}$	Output current with power off	$V_{CC} = 0, V_O = -0.25\text{ V or } 5.5\text{ V}$			μA
I_{OZ}	High-impedance state output current	$V_O = -0.25\text{ V or } 5.5\text{ V}, G = 0.8\text{ V or } \overline{G} = 2\text{ V}$			μA
I_I	Input current	$V_{CC} = 0\text{ or } 3.6\text{ V}, V_I = 0\text{ or } 5.5\text{ V}$			μA
I_{OS}	Short-circuit output current	$V_O = V_{CC}\text{ or GND}$ ⁽³⁾			mA
I_{CC}	Supply current (total package)	$V_I = V_{CC}\text{ or GND}, \text{ No load, enable}$			μA
C_{pd}	Power dissipation capacitance	No load ⁽⁴⁾			pF

(1) All typical values are at $V_{CC} = 3.3\text{ V}, T_A = 25^\circ\text{C}$.

(2) Refer to TIA-EIA-422-B for exact conditions.

(3) Not more than one output should be shorted at a time, and the duration of the short circuit should not exceed one second.

(4) C_{pd} determines the no-load dynamic current consumption: $I_S = C_{pd} \times V_{CC} \times f + I_{CC}$

SWITCHING CHARACTERISTICS

over recommended ranges of supply voltage and operating free-air temperature (unless otherwise noted)

PARAMETER		TEST CONDITIONS	MIN	TYP ⁽¹⁾	MAX	UNIT
t_{PHL}	Propagation delay time, high- to low-level output	See Figure 2	4	8	12	ns
t_{PLH}	Propagation delay time, low- to high-level output		3.5	8	12	ns
t_t	Transition time (t_r or t_f)	See Figure 2		5	10	ns
t_{PZH}	Output-enable time to high level	See Figure 3		10	20	ns
t_{PZL}	Output-enable time to low level	See Figure 4		10	20	ns
t_{PHZ}	Output-disable time from high level	See Figure 3		10	20	ns
t_{PLZ}	Output-disable time from low level	See Figure 4		10	20	ns
$t_{sk(p)}$	Pulse skew	See Figure 2 ⁽²⁾⁽³⁾		0.5	3	ns
$t_{sk(o)}$	Skew limit (pin to pin)				1.5	ns
$t_{sk(lim)}$	Skew limit (device to device)				3	ns
$f_{(max)}$	Maximum operating frequency	See Figure 2		32		MHz

(1) All typical values are at $V_{CC} = 3.3\text{ V}$, $T_A = 25^\circ\text{C}$.

(2) Pulse skew is defined as the $|t_{PLH} - t_{PHL}|$ of each channel of the same device.

(3) Skew limit (device to device) is the maximum difference in propagation delay times between any two channels of any two devices.

ESD PROTECTION

PARAMETER	TEST CONDITIONS	TYP	UNIT
Driver output	HBM	±15	kV
	IEC61000-4-2, Air-Gap Discharge	±15	
	IEC61000-4-2, Contact Discharge	±8	

PARAMETER MEASUREMENT INFORMATION

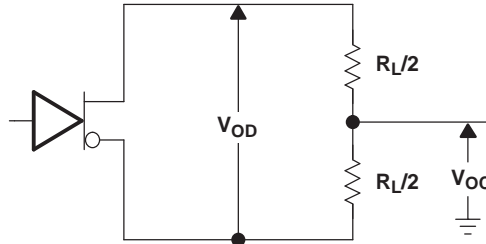
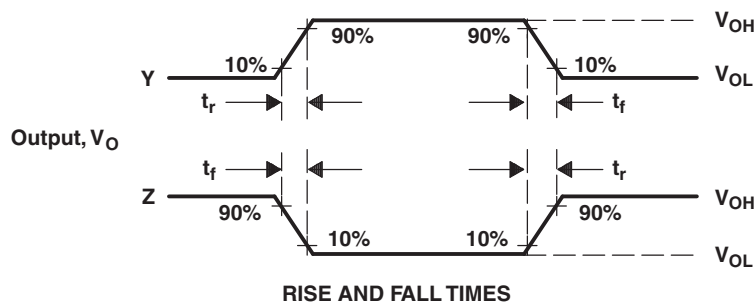
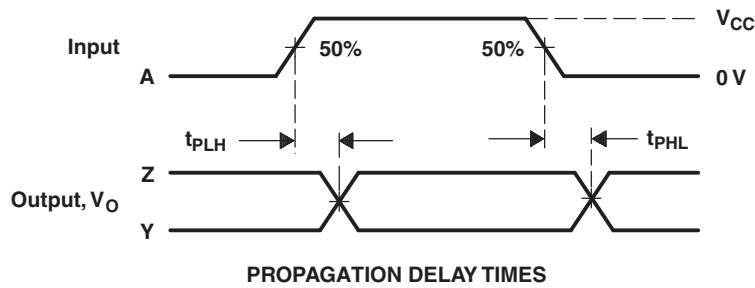
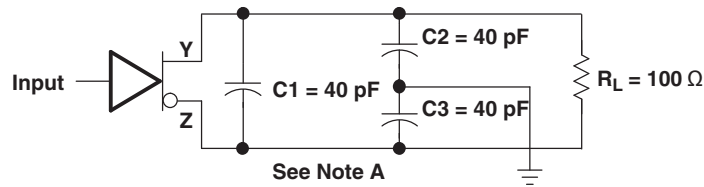

Figure 1. Test Circuit, V_{OD} and V_{OC}



- NOTES: A. C_L includes probe and jig capacitance.
 B. The input pulse is supplied by a generator having the following characteristics: PRR = 32 MHz, 50% duty cycle, t_r and $t_f \leq 2$ ns.

Figure 2. Test Circuit and Voltage Waveforms, t_{PHL} and t_{PLH}

PARAMETER MEASUREMENT INFORMATION (continued)

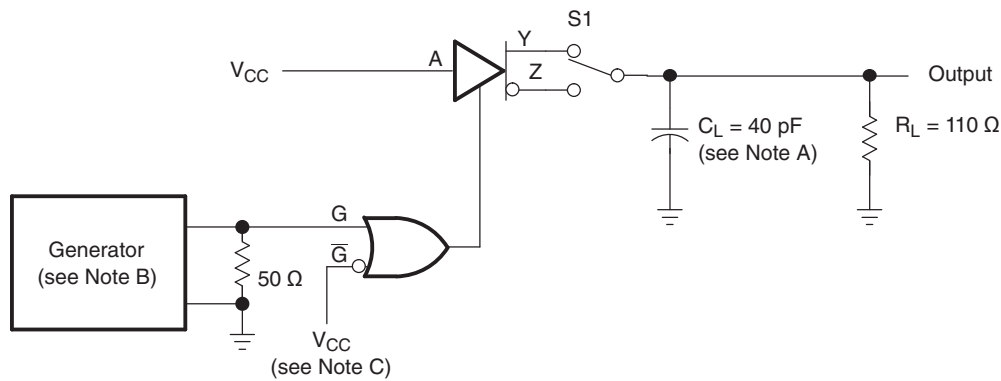

TEST CIRCUIT

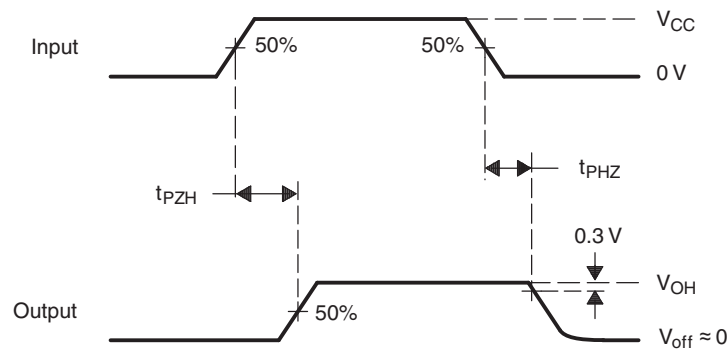

VOLTAGE WAVEFORMS

- A. C_L includes probe and jig capacitance.
- B. The input pulse is supplied by a generator having the following characteristics: PRR = 10 MHz, duty cycle = 50%, $t_r = t_f \leq 2\text{ns}$.
- C. To test the active-low enable \bar{G} , ground G and apply an inverted waveform \bar{G} .

Figure 3. Test Circuit and Voltage Waveforms, t_{PZH} and t_{PHZ}

PARAMETER MEASUREMENT INFORMATION (continued)

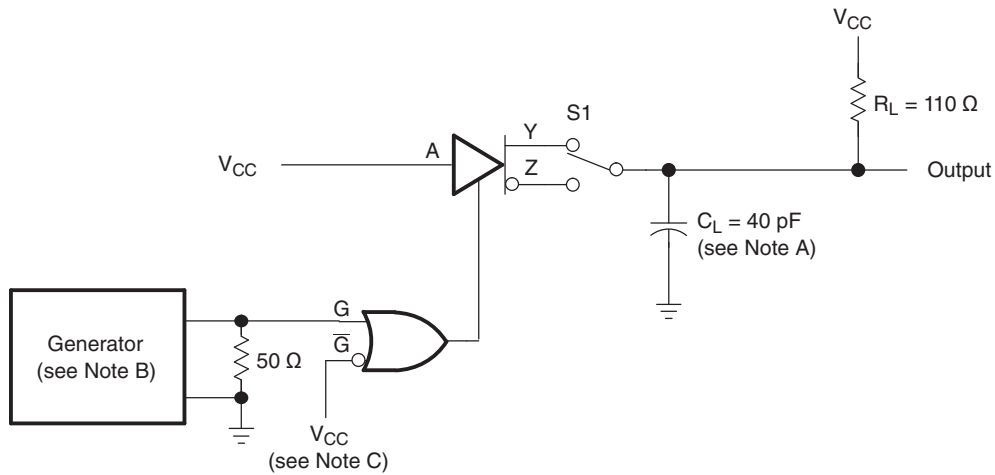

TEST CIRCUIT

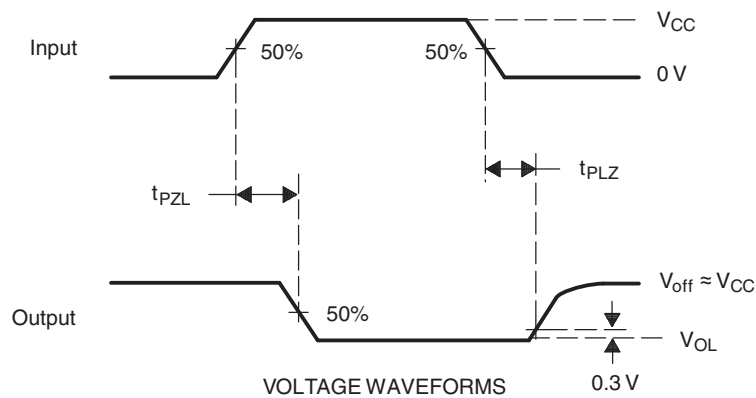

VOLTAGE WAVEFORMS

- C_L includes probe and jig capacitance.
- The input pulse is supplied by a generator having the following characteristics: PRR = 10 MHz, duty cycle = 50%, $t_r = t_f \leq 2\text{ns}$.
- To test the active-low enable \overline{G} , ground G and apply an inverted waveform \overline{G} .

Figure 4. Test Circuit and Voltage Waveforms, t_{PZL} and t_{PLZ}

PACKAGING INFORMATION

Orderable Device	Status (1)	Package Type	Package Drawing	Pins	Package Qty	Eco Plan (2)	Lead finish/ Ball material (6)	MSL Peak Temp (3)	Op Temp (°C)	Device Marking (4/5)	Samples
AM26LV31ESDREP	ACTIVE	SOIC	D	16	2500	RoHS & Green	NIPDAU	Level-1-260C-UNLIM	-55 to 105	A26LV31ESP	Samples
V62/09603-01XE	ACTIVE	SOIC	D	16	2500	RoHS & Green	NIPDAU	Level-1-260C-UNLIM	-55 to 105	A26LV31ESP	Samples

(1) The marketing status values are defined as follows:

ACTIVE: Product device recommended for new designs.

LIFEBUY: TI has announced that the device will be discontinued, and a lifetime-buy period is in effect.

NRND: Not recommended for new designs. Device is in production to support existing customers, but TI does not recommend using this part in a new design.

PREVIEW: Device has been announced but is not in production. Samples may or may not be available.

OBSOLETE: TI has discontinued the production of the device.

(2) **RoHS:** TI defines "RoHS" to mean semiconductor products that are compliant with the current EU RoHS requirements for all 10 RoHS substances, including the requirement that RoHS substance do not exceed 0.1% by weight in homogeneous materials. Where designed to be soldered at high temperatures, "RoHS" products are suitable for use in specified lead-free processes. TI may reference these types of products as "Pb-Free".

RoHS Exempt: TI defines "RoHS Exempt" to mean products that contain lead but are compliant with EU RoHS pursuant to a specific EU RoHS exemption.

Green: TI defines "Green" to mean the content of Chlorine (Cl) and Bromine (Br) based flame retardants meet JS709B low halogen requirements of <=1000ppm threshold. Antimony trioxide based flame retardants must also meet the <=1000ppm threshold requirement.

(3) MSL, Peak Temp. - The Moisture Sensitivity Level rating according to the JEDEC industry standard classifications, and peak solder temperature.

(4) There may be additional marking, which relates to the logo, the lot trace code information, or the environmental category on the device.

(5) Multiple Device Markings will be inside parentheses. Only one Device Marking contained in parentheses and separated by a "~" will appear on a device. If a line is indented then it is a continuation of the previous line and the two combined represent the entire Device Marking for that device.

(6) Lead finish/Ball material - Orderable Devices may have multiple material finish options. Finish options are separated by a vertical ruled line. Lead finish/Ball material values may wrap to two lines if the finish value exceeds the maximum column width.

Important Information and Disclaimer:The information provided on this page represents TI's knowledge and belief as of the date that it is provided. TI bases its knowledge and belief on information provided by third parties, and makes no representation or warranty as to the accuracy of such information. Efforts are underway to better integrate information from third parties. TI has taken and continues to take reasonable steps to provide representative and accurate information but may not have conducted destructive testing or chemical analysis on incoming materials and chemicals. TI and TI suppliers consider certain information to be proprietary, and thus CAS numbers and other limited information may not be available for release.

In no event shall TI's liability arising out of such information exceed the total purchase price of the TI part(s) at issue in this document sold by TI to Customer on an annual basis.

OTHER QUALIFIED VERSIONS OF AM26LV31E-EP :

- Catalog : [AM26LV31E](#)

NOTE: Qualified Version Definitions:

- Catalog - TI's standard catalog product

D (R-PDSO-G16)

PLASTIC SMALL OUTLINE



- NOTES:
- A. All linear dimensions are in inches (millimeters).
 - B. This drawing is subject to change without notice.
 - C. Body length does not include mold flash, protrusions, or gate burrs. Mold flash, protrusions, or gate burrs shall not exceed 0.006 (0,15) each side.
 - D. Body width does not include interlead flash. Interlead flash shall not exceed 0.017 (0,43) each side.
 - E. Reference JEDEC MS-012 variation AC.

IMPORTANT NOTICE AND DISCLAIMER

TI PROVIDES TECHNICAL AND RELIABILITY DATA (INCLUDING DATA SHEETS), DESIGN RESOURCES (INCLUDING REFERENCE DESIGNS), APPLICATION OR OTHER DESIGN ADVICE, WEB TOOLS, SAFETY INFORMATION, AND OTHER RESOURCES "AS IS" AND WITH ALL FAULTS, AND DISCLAIMS ALL WARRANTIES, EXPRESS AND IMPLIED, INCLUDING WITHOUT LIMITATION ANY IMPLIED WARRANTIES OF MERCHANTABILITY, FITNESS FOR A PARTICULAR PURPOSE OR NON-INFRINGEMENT OF THIRD PARTY INTELLECTUAL PROPERTY RIGHTS.

These resources are intended for skilled developers designing with TI products. You are solely responsible for (1) selecting the appropriate TI products for your application, (2) designing, validating and testing your application, and (3) ensuring your application meets applicable standards, and any other safety, security, regulatory or other requirements.

These resources are subject to change without notice. TI grants you permission to use these resources only for development of an application that uses the TI products described in the resource. Other reproduction and display of these resources is prohibited. No license is granted to any other TI intellectual property right or to any third party intellectual property right. TI disclaims responsibility for, and you will fully indemnify TI and its representatives against, any claims, damages, costs, losses, and liabilities arising out of your use of these resources.

TI's products are provided subject to [TI's Terms of Sale](#) or other applicable terms available either on [ti.com](https://www.ti.com) or provided in conjunction with such TI products. TI's provision of these resources does not expand or otherwise alter TI's applicable warranties or warranty disclaimers for TI products.

TI objects to and rejects any additional or different terms you may have proposed.

Mailing Address: Texas Instruments, Post Office Box 655303, Dallas, Texas 75265
Copyright © 2024, Texas Instruments Incorporated

Looking for pricing, stock, or lifecycle information?

Click below to explore more details on WIN SOURCE:

⊖ [View AM26LV31ESDREP](#) on WIN SOURCE

⊖ [Texas Instruments](#) Information

Optimize Your Supply Chain with WIN SOURCE Solutions

- ✓ Global Sourcing Solution
- ✓ Obsolete Management
- ✓ Cost Control Management
- ✓ Shortage Management
- ✓ Alternative Solution
- ✓ Excess Inventory Management