



THE DATASHEET OF STP5NK90Z





STP5NK90Z STF5NK90Z

N-channel 900V - 2Ω - 4.5A - TO-220/TO-220FP
Zener - Protected SuperMESH™ MOSFET

General features

Type	V _{DSS} (@T _{Jmax})	R _{DS(on)}	I _D	P _W
STP5NK90Z	900 V	< 2.5 Ω	4.5 A	125W
STF5NK90Z	900 V	< 2.5 Ω	4.5 A ⁽¹⁾	30W

1. Limited only by maximum temperature allowed

- Extremely high dv/dt capability
- Improved esd capability
- 100% avalanche rated
- Gate charge minimized
- Very low intrinsic capacitances
- Very good manufacturing repeatability

Description

The SuperMESH™ series is obtained through an extreme optimization of ST's well established stripbased PowerMESH™ layout. In addition to pushing on-resistance significantly down, special care is taken to ensure a very good dv/dt capability for the most demanding applications. Such series complements ST full range of high voltage MOSFETs including revolutionary MDmesh™ products.

Applications

- Switching application

Order codes

Part number	Marking	Package	Packaging
STP5NK90Z	P5NK90Z	TO-220	Tube
STF5NK90Z	F5NK90Z	TO-220FP	Tube

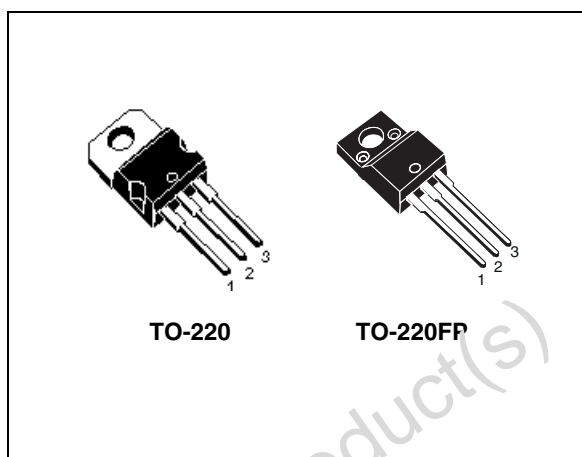

Internal schematic diagram

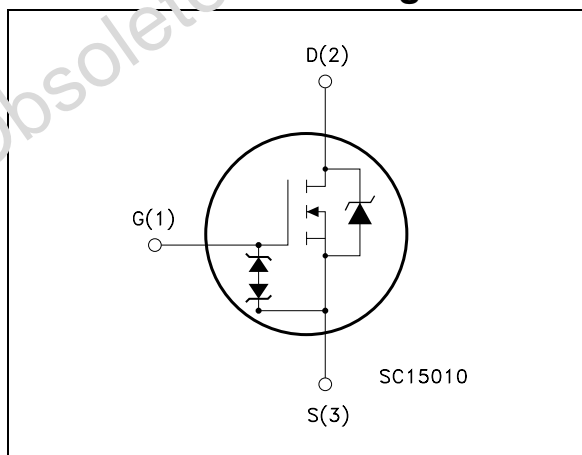

Contents

- 1 Electrical ratings 3**
 - 1.1 Protection features of gate-to-source zener diodes 4

- 2 Electrical characteristics 5**
 - 2.1 Electrical characteristics (curves) 7

- 3 Test circuit Package mechanical data 10**

- 4 Package mechanical data 11**

- 5 Revision history 14**

Obsolete Product(s) - Obsolete Product(s)

1 Electrical ratings

Table 1. Absolute maximum ratings

Symbol	Parameter	Value		Unit
		STP5NK90Z	STF5NK90Z	
V_{DS}	Drain-source voltage ($V_{GS} = 0$)	900		V
V_{DGR}	Drain-gate voltage ($R_{GS} = 20K\Omega$)	900		V
V_{GS}	Gate-source voltage	± 30		V
I_D	Drain current (continuous) at $T_C = 25^\circ C$	4.5	4.5 ⁽²⁾	A
I_D	Drain current (continuous) at $T_C = 100^\circ C$	2.8	2.8 ⁽²⁾	A
$I_{DM}^{(1)}$	Drain current (pulsed)	18	18 ⁽²⁾	A
P_{TOT}	Total dissipation at $T_C = 25^\circ C$	125	30	W
	Derating Factor	1	0.24	W/°C
$V_{ESD(G-S)}$	Gate source ESD (HBM-C=100pF, R=1.5KΩ)	4000		V
$dv/dt^{(3)}$	Peak diode recovery voltage slope	4.5		V/ns
V_{ISO}	Insulation withstand voltage (DC)	-	2500	V
T_J	Operating junction temperature	-55 to 150		°C
T_{stg}	Storage temperature	-55 to 150		°C

1. Pulse width limited by safe operation area
2. Limited only by maximum temperature allowed
3. $I_{SD} \leq 4.5$ A, $di/dt \leq 200$ A/μs, $V_{DD} \leq V_{(BR)DSS}$, $T_J \leq T_{JMAX}$

Table 2. Thermal data

Symbol	Parameter	Value		Unit
		TO-220	TO-220FP	
$R_{thj-case}$	Thermal resistance junction-case Max	1	4.2	°C/W
R_{thj-a}	Thermal resistance junction-ambient Max	62.5		°C/W
T_l	Maximum lead temperature for soldering purpose	300		°C

Table 3. Avalanche characteristics

Symbol	Parameter	Max Value	Unit
I_{AR}	Avalanche current, repetitive or not-repetitive (pulse width limited by T_J Max)	4.5	A
E_{AS}	Single pulse avalanche energy (starting $T_J = 25^\circ C$, $I_d = I_{AR}$, $V_{DD} = 50V$)	230	mJ

Table 4. Gate-source zener diode

Symbol	Parameter	Test conditions	Min	Typ.	Max	Unit
BV_{GSO}	Gate-Source breakdown voltage	$I_{GS}=\pm 1\text{mA}$ (Open drain)	30			V

1.1 Protection features of gate-to-source zener diodes

The built-in back-to-back Zener diodes have specifically been designed to enhance not only the device's ESD capability, but also to make them safely absorb possible voltage transients that may occasionally be applied from gate to source. In this respect the Zener voltage is appropriate to achieve an efficient and cost-effective intervention to protect the device's integrity. These integrated Zener diodes thus avoid the usage of external components.

Obsolete Product(s) - Obsolete Product(s)

2 Electrical characteristics

($T_{CASE}=25^{\circ}C$ unless otherwise specified)

Table 5. On/off states

Symbol	Parameter	Test conditions	Min.	Typ.	Max.	Unit
$V_{(BR)DSS}$	Drain-source breakdown voltage	$I_D = 1mA, V_{GS} = 0$	900			V
I_{DSS}	Zero gate voltage drain current ($V_{GS} = 0$)	$V_{DS} = \text{Max rating},$ $V_{DS} = \text{Max rating}, T_c=125^{\circ}C$			1 50	μA μA
I_{GSS}	Gate body leakage current ($V_{GS} = 0$)	$V_{GS} = \pm 20V$			± 10	μA
$V_{GS(th)}$	Gate threshold voltage	$V_{DS} = V_{GS}, I_D = 100\mu A$	3	3.75	4.5	V
$R_{DS(on)}$	Static drain-source on resistance	$V_{GS} = 10 V, I_D = 2.25 A$		2	2.5	Ω

Table 6. Dynamic

Symbol	Parameter	Test conditions	Min.	Typ.	Max.	Unit
$g_{fs}^{(1)}$	Forward transconductance	$V_{DS} = 15V, I_D = 2.25A$		4.8		S
C_{iss}	Input capacitance	$V_{DS} = 25V, f = 1 \text{ MHz}, V_{GS} = 0$		1160		pF
C_{oss}	Output capacitance			105		pF
C_{rss}	Reverse transfer capacitance			21.5		pF
$C_{osseq}^{(2)}$	Equivalent output capacitance	$V_{GS} = 0, V_{DS} = 0V \text{ to } 720V$		65.5		pF
$t_{d(on)}$	Turn-on delay time	$V_{DD} = 400 V, I_D = 2.2 A,$ $R_G = 4.7\Omega, V_{GS} = 10V$ (see Figure 19)		27		ns
t_r	Rise time			7.2		ns
$t_{d(off)}$	Off-voltage rise time			52		ns
t_f	Fall time			19		ns
Q_g	Total gate charge	$V_{DD} = 720V, I_D = 4.4A$		41.5		nC
Q_{gs}	Gate-source charge	$V_{GS} = 10V$		69		nC
Q_{gd}	Gate-drain charge	(see Figure 18)		21.9		nC

1. Pulsed: pulse duration=300 μs , duty cycle 1.5%

2. $C_{oss eq.}$ is defined as a constant equivalent capacitance giving the same charging time as C_{oss} when V_{DS} increases from 0 to 80% V_{DSS}

Table 7. Source drain diode

Symbol	Parameter	Test conditions	Min	Typ.	Max	Unit
I_{SD}	Source-drain current				4.5	A
$I_{SDM}^{(1)}$	Source-drain current (pulsed)				18	A
$V_{SD}^{(2)}$	Forward on voltage	$I_{SD} = 4.5A, V_{GS}=0$			1.6	V
t_{rr}	Reverse recovery time	$I_{SD} = 4.5 A, di/dt = 100 A/\mu s$		635		ns
Q_{rr}	Reverse recovery charge	$V_{DD} = 35 V$		5.9		μC
I_{RRM}	Reverse recovery current	(see Figure 18)		18.5		A
t_{rr}	Reverse recovery time	$I_{SD} = 4.5 A, di/dt = 100 A/\mu s$		712		ns
Q_{rr}	Reverse recovery charge	$V_{DD} = 35 V,$ $T_j = 150 ^\circ C$		4.66		μC
I_{RRM}	Reverse recovery current	(see Figure 18)		13.1		A

1. Pulse width limited by safe operating area

Obsolete Product(s) - Obsolete Product(s)

2. Pulsed: pulse duration=300µs, duty cycle 1.5%

2.1 Electrical characteristics (curves)

Figure 1. Safe operating area for TO 220

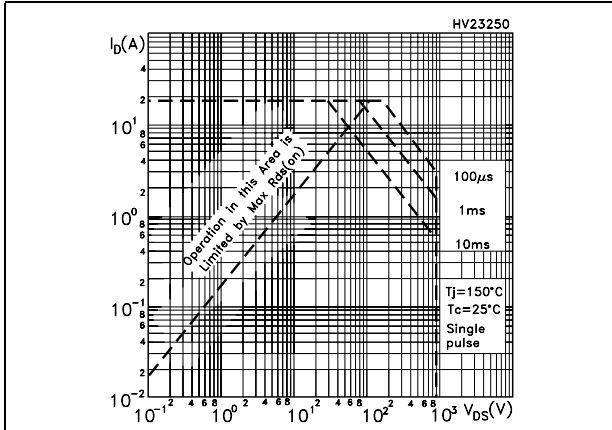

Figure 2. Thermal impedance for TO-220

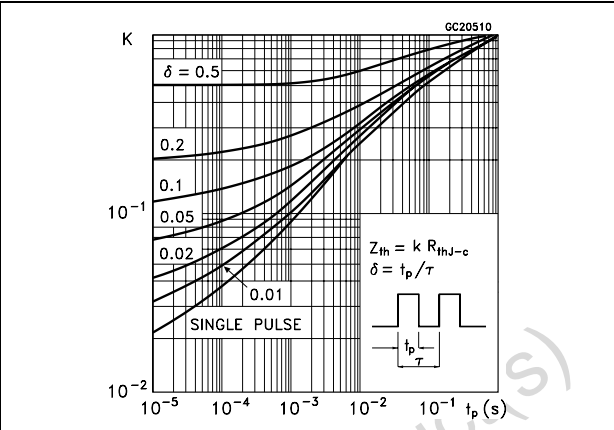

Figure 3. Safe operating area for TO-220FP

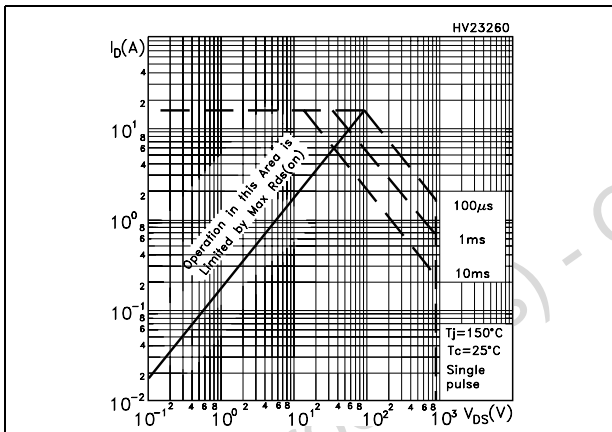

Figure 4. Thermal impedance for TO-220FP

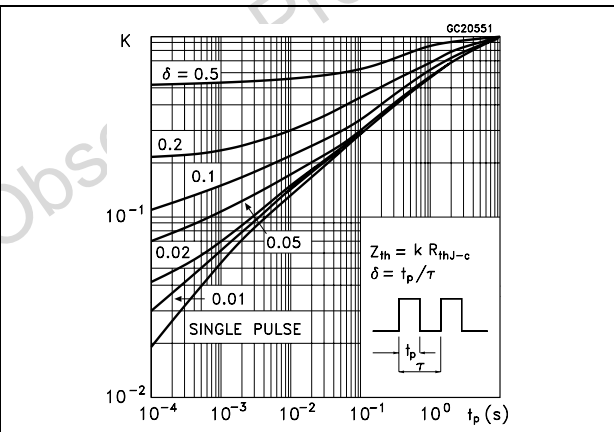

Figure 5. Output characteristics

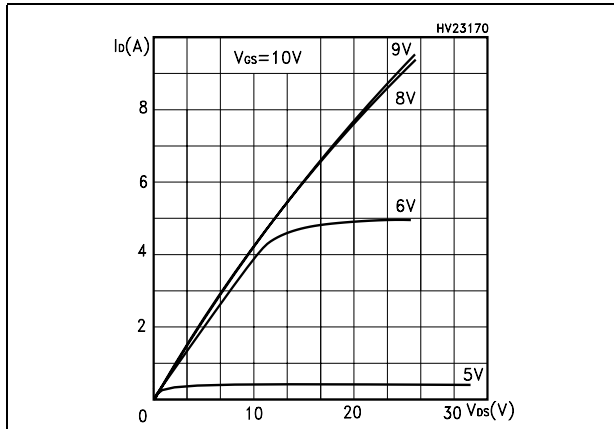

Figure 6. Transfer characteristics

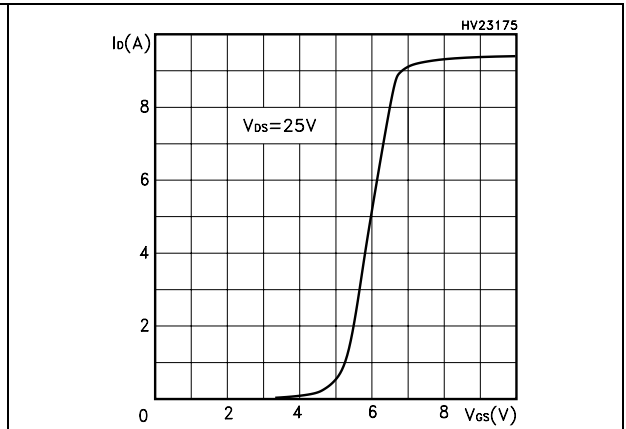

Figure 7. Transconductance

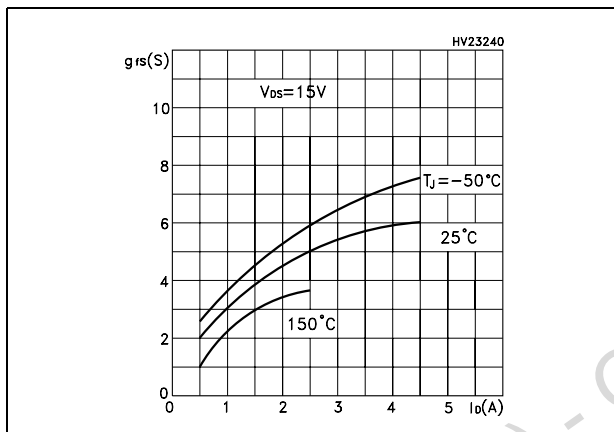

Figure 8. Static drain-source on resistance

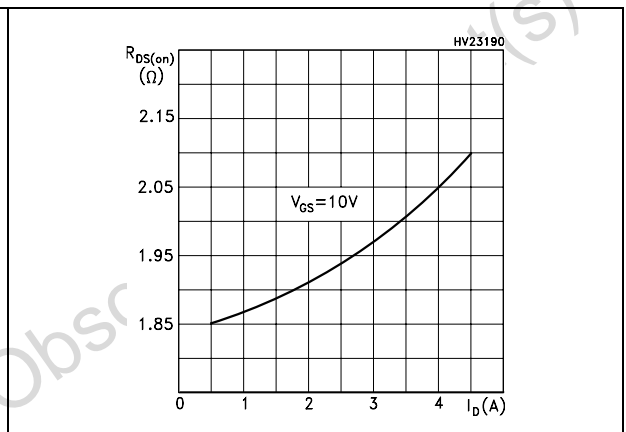

Figure 9. Gate charge vs gate-source voltage

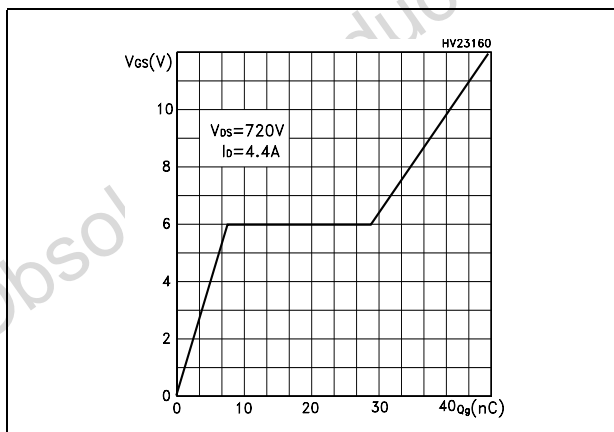

Figure 10. Capacitance variations

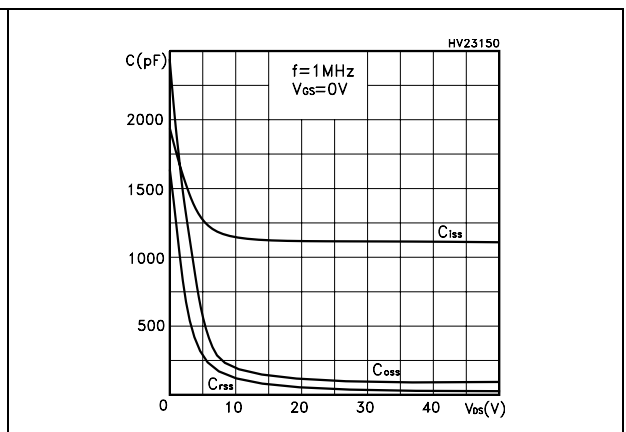

Figure 11. Normalized gate threshold voltage vs temperature

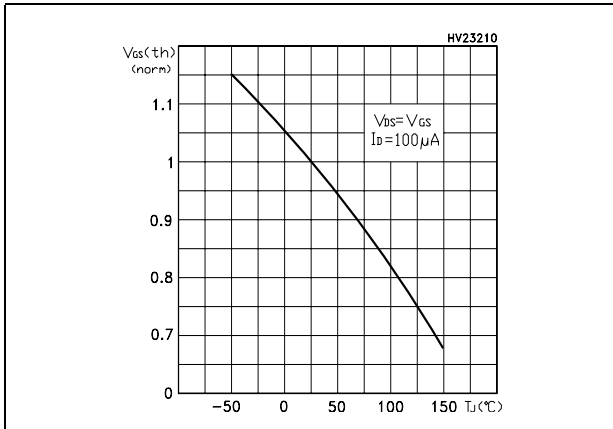

Figure 12. Normalized on resistance vs temperature

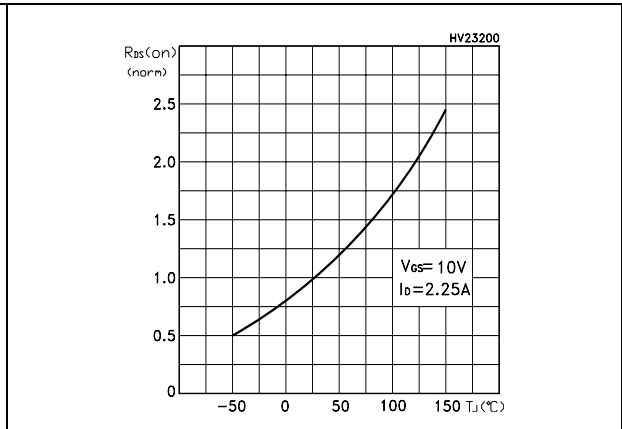

Figure 13. Source-drain diode forward characteristics

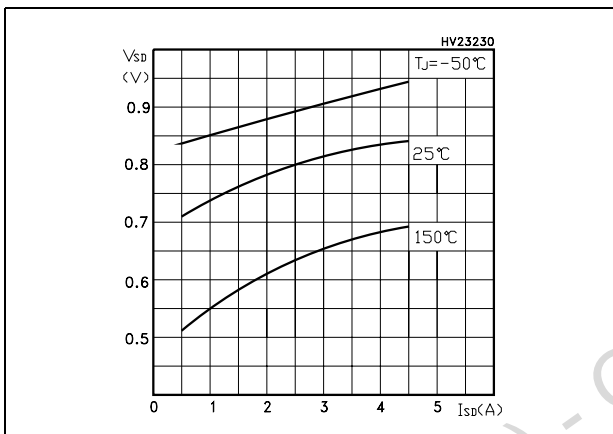

Figure 14. Avalanche Energy vs starting Tj

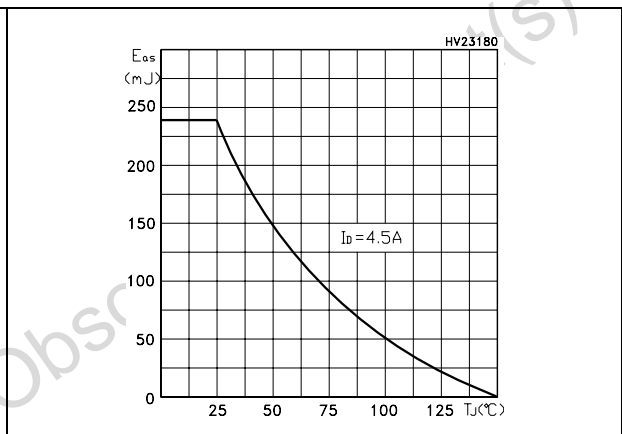
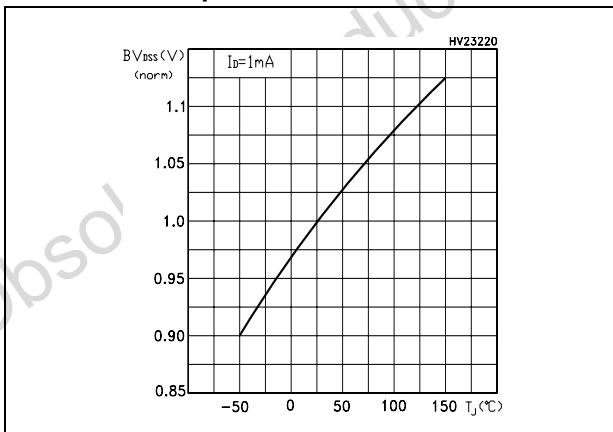

Figure 15. Normalized breakdown voltage vs temperature



3 Test circuit Package mechanical data

Figure 16. Unclamped inductive load test circuit

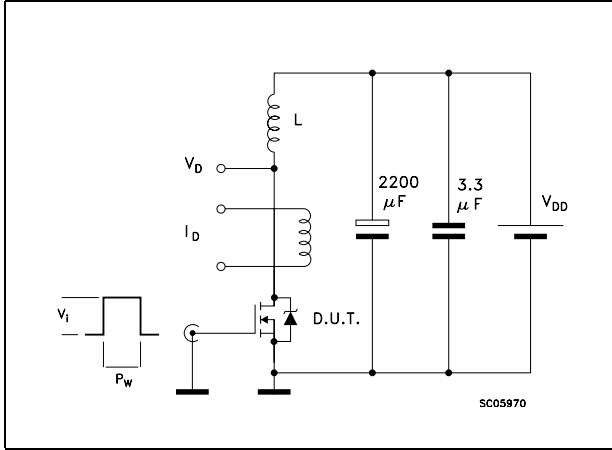

Figure 17. Unclamped inductive waveform

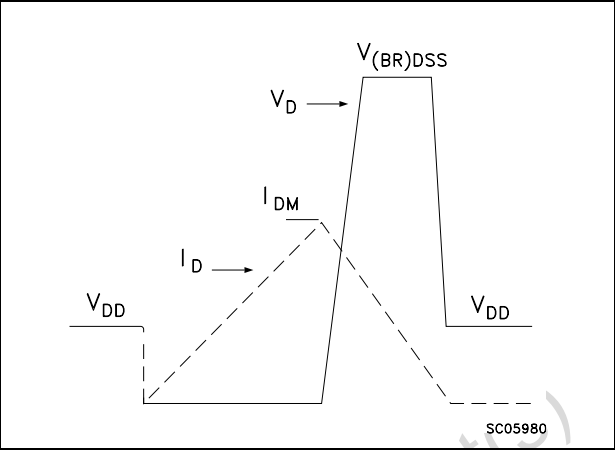

Figure 18. Switching times test circuit for resistive load

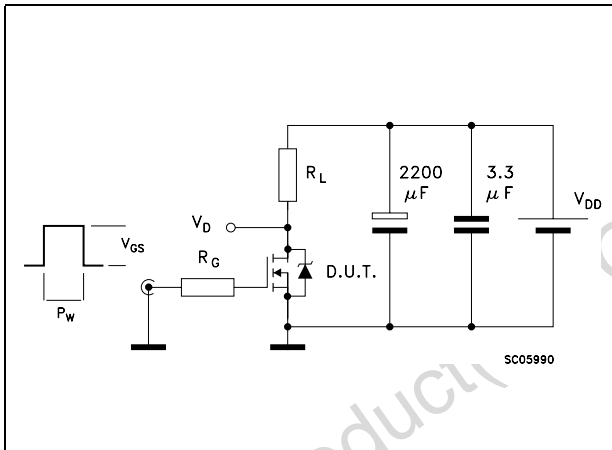

Figure 19. Gate charge test circuit

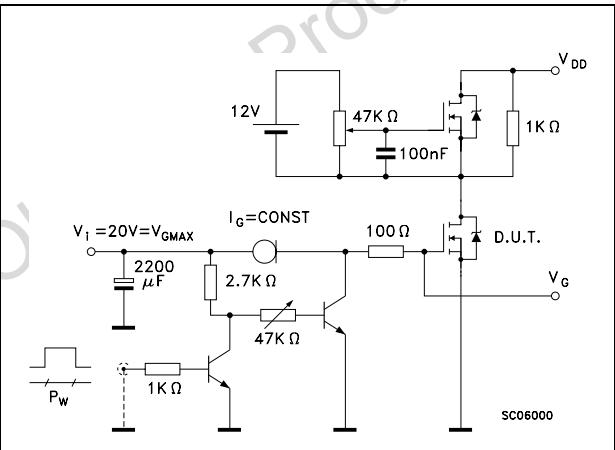
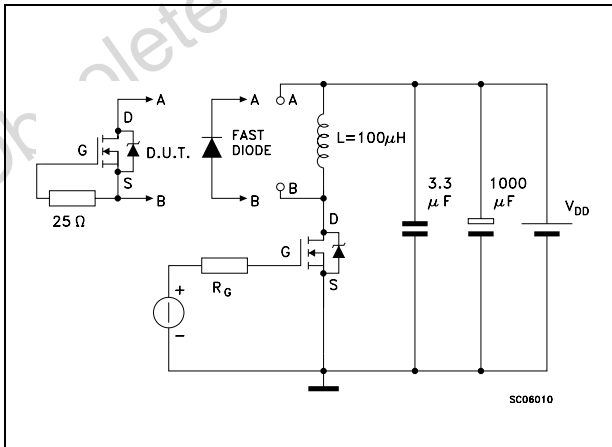

Figure 20. Test circuit for inductive load switching and diode recovery times



4 Package mechanical data

In order to meet environmental requirements, ST offers these devices in ECOPACK® packages. These packages have a Lead-free second level interconnect . The category of second level interconnect is marked on the package and on the inner box label, in compliance with JEDEC Standard JESD97. The maximum ratings related to soldering conditions are also marked on the inner box label. ECOPACK is an ST trademark. ECOPACK specifications are available at: www.st.com

Obsolete Product(s) - Obsolete Product(s)

TO-220FP MECHANICAL DATA

DIM.	mm.			inch		
	MIN.	TYP	MAX.	MIN.	TYP.	MAX.
A	4.4		4.6	0.173		0.181
B	2.5		2.7	0.098		0.106
D	2.5		2.75	0.098		0.108
E	0.45		0.7	0.017		0.027
F	0.75		1	0.030		0.039
F1	1.15		1.7	0.045		0.067
F2	1.15		1.7	0.045		0.067
G	4.95		5.2	0.195		0.204
G1	2.4		2.7	0.094		0.106
H	10		10.4	0.393		0.409
L2		16			0.630	
L3	28.6		30.6	1.126		1.204
L4	9.8		10.6	.0385		0.417
L5	2.9		3.6	0.114		0.141
L6	15.9		16.4	0.626		0.645
L7	9		9.3	0.354		0.366
Ø	3		3.2	0.118		0.126

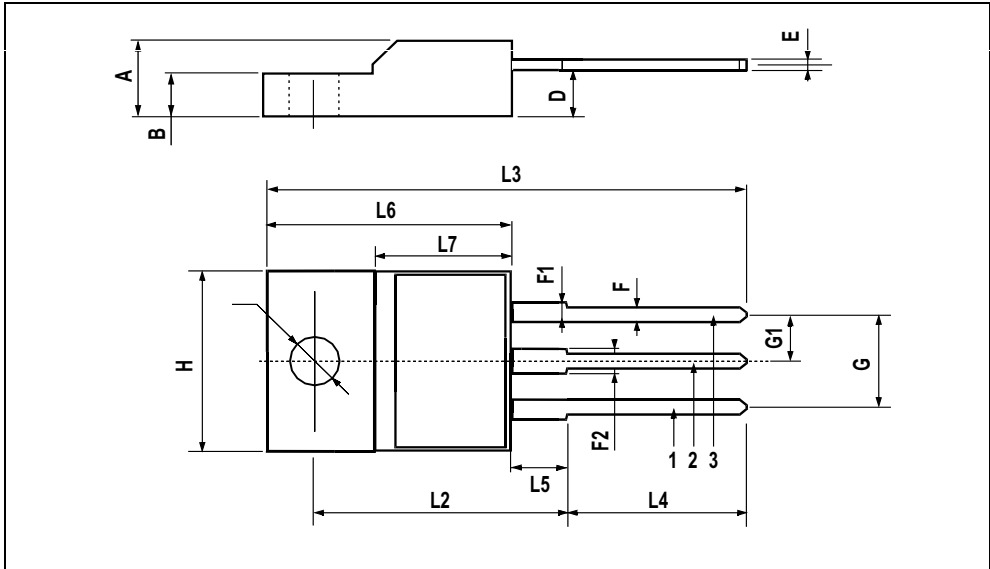

Obsole

TO-220 MECHANICAL DATA

DIM.	mm.			inch		
	MIN.	TYP.	MAX.	MIN.	TYP.	MAX.
A	4.40		4.60	0.173		0.181
b	0.61		0.88	0.024		0.034
b1	1.15		1.70	0.045		0.066
c	0.49		0.70	0.019		0.027
D	15.25		15.75	0.60		0.620
E	10		10.40	0.393		0.409
e	2.40		2.70	0.094		0.106
e1	4.95		5.15	0.194		0.202
F	1.23		1.32	0.048		0.052
H1	6.20		6.60	0.244		0.256
J1	2.40		2.72	0.094		0.107
L	13		14	0.511		0.551
L1	3.50		3.93	0.137		0.154
L20		16.40			0.645	
L30		28.90			1.137	
øP	3.75		3.85	0.147		0.151
Q	2.65		2.95	0.104		0.116

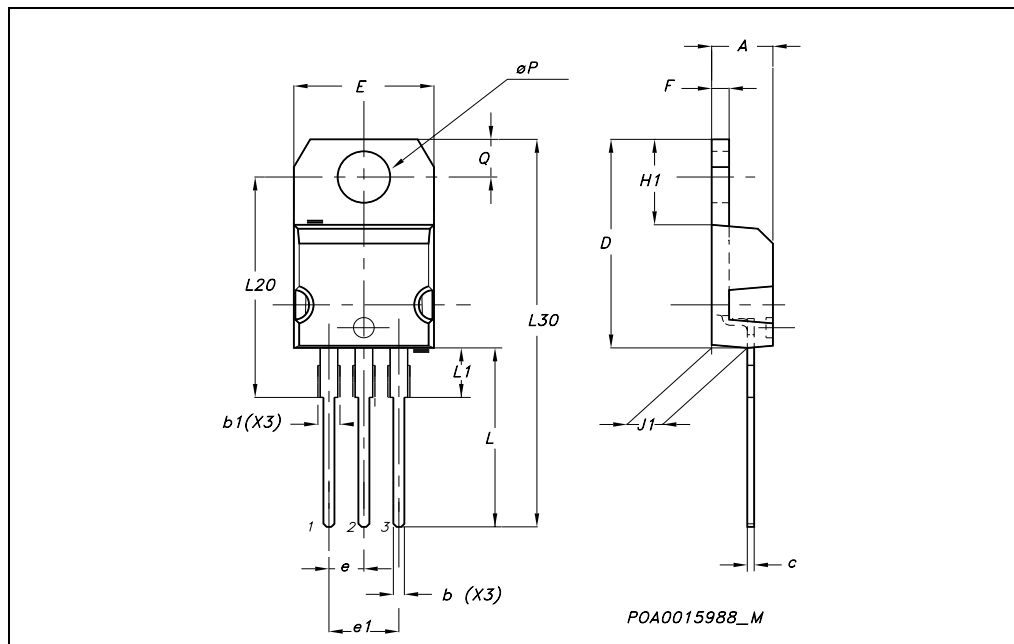

5 Revision history

Table 8. Revision history

Date	Revision	Changes
06-Oct-2004	1	First release
08-Sep-2005	2	Complete datasheet
14-Dec-2005	3	Inserted Ecopack indication
31-Jul-2005	4	New template, no content change

Obsolete Product(s) - Obsolete Product(s)

Please Read Carefully:

Information in this document is provided solely in connection with ST products. STMicroelectronics NV and its subsidiaries ("ST") reserve the right to make changes, corrections, modifications or improvements, to this document, and the products and services described herein at any time, without notice.

All ST products are sold pursuant to ST's terms and conditions of sale.

Purchasers are solely responsible for the choice, selection and use of the ST products and services described herein, and ST assumes no liability whatsoever relating to the choice, selection or use of the ST products and services described herein.

No license, express or implied, by estoppel or otherwise, to any intellectual property rights is granted under this document. If any part of this document refers to any third party products or services it shall not be deemed a license grant by ST for the use of such third party products or services, or any intellectual property contained therein or considered as a warranty covering the use in any manner whatsoever of such third party products or services or any intellectual property contained therein.

UNLESS OTHERWISE SET FORTH IN ST'S TERMS AND CONDITIONS OF SALE ST DISCLAIMS ANY EXPRESS OR IMPLIED WARRANTY WITH RESPECT TO THE USE AND/OR SALE OF ST PRODUCTS INCLUDING WITHOUT LIMITATION IMPLIED WARRANTIES OF MERCHANTABILITY, FITNESS FOR A PARTICULAR PURPOSE (AND THEIR EQUIVALENTS UNDER THE LAWS OF ANY JURISDICTION), OR INFRINGEMENT OF ANY PATENT, COPYRIGHT OR OTHER INTELLECTUAL PROPERTY RIGHT.

UNLESS EXPRESSLY APPROVED IN WRITING BY AN AUTHORIZED ST REPRESENTATIVE, ST PRODUCTS ARE NOT RECOMMENDED, AUTHORIZED OR WARRANTED FOR USE IN MILITARY, AIR CRAFT, SPACE, LIFE SAVING, OR LIFE SUSTAINING APPLICATIONS, NOR IN PRODUCTS OR SYSTEMS WHERE FAILURE OR MALFUNCTION MAY RESULT IN PERSONAL INJURY, DEATH, OR SEVERE PROPERTY OR ENVIRONMENTAL DAMAGE. ST PRODUCTS WHICH ARE NOT SPECIFIED AS "AUTOMOTIVE GRADE" MAY ONLY BE USED IN AUTOMOTIVE APPLICATIONS AT USER'S OWN RISK.

Resale of ST products with provisions different from the statements and/or technical features set forth in this document shall immediately void any warranty granted by ST for the ST product or service described herein and shall not create or extend in any manner whatsoever, any liability of ST.

ST and the ST logo are trademarks or registered trademarks of ST in various countries.

Information in this document supersedes and replaces all information previously supplied.

The ST logo is a registered trademark of STMicroelectronics. All other names are the property of their respective owners.

© 2006 STMicroelectronics - All rights reserved

STMicroelectronics group of companies

Australia - Belgium - Brazil - Canada - China - Czech Republic - Finland - France - Germany - Hong Kong - India - Israel - Italy - Japan - Malaysia - Malta - Morocco - Singapore - Spain - Sweden - Switzerland - United Kingdom - United States of America

www.st.com

Looking for pricing, stock, or lifecycle information?

Click below to explore more details on WIN SOURCE:

- ⊖ [View STP5NK90Z on WIN SOURCE](#)
- ⊖ [STMicroelectronics Information](#)

Optimize Your Supply Chain with WIN SOURCE Solutions

- ✓ Global Sourcing Solution
- ✓ Obsolete Management
- ✓ Cost Control Management
- ✓ Shortage Management
- ✓ Alternative Solution
- ✓ Excess Inventory Management