



THE DATASHEET OF STABP01D





STABP01

BASH® DIGITAL FIDELITY DIGITAL PROCESSOR

■ BASH® LICENCE REQUIRED

DESCRIPTION

The STABP01 processor is used to control the BASH® Digital Converter. When used in conjunction with BASH® amplifiers a fully integrated high efficiency power amplifier is realized.

By analyzing the audio input, the Processor determines the appropriate on/off events and generates a digital pulse for the Digital Converter. The converter turns this pulse into a power signal that feeds the power amplifier. The feedback system allows the processor to constantly adapt to the audio signal and regenerate the digital pulse thereby maintaining a constant voltage across the output devices.

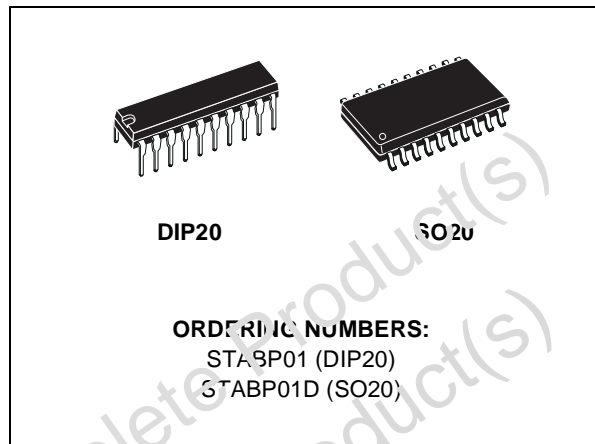

BLOCK DIAGRAM

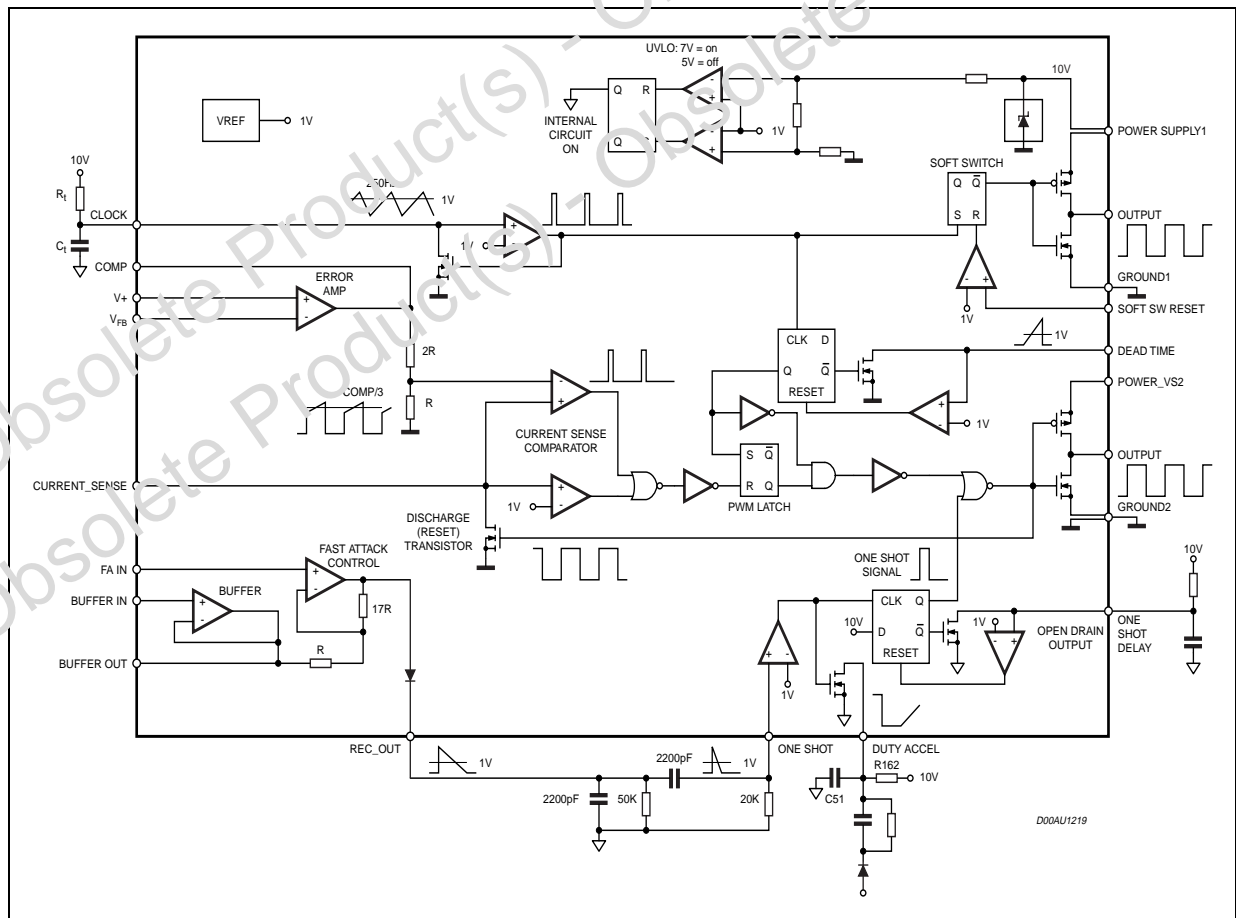

STABP01

ABSOLUTE MAXIMUM RATINGS

Symbol	Parameter	Value	Unit
Vs	Supply Voltage	10.5	V
Io	Output Current	±0.6	A
Eo	Output Energy(capacitive load)	5	μJ
Vi	Analog Input Voltage	-0.3 to 8	V
Io	Error Amplifier Output Sink Current	10	mA
P _{tot}	Power Dissipation at Tamb	500	mW
T _{stg}	Storage Ambient Temperature	-65 to 150	°C
T _L	Lead Temperature (soldering 10s)	300	°C
T _{op}	Operating Temperature Range	-25 to 85	°C

THERMAL DATA

Symbol	Parameter	SO20	DIP20	Unit
R _{th j-amb}	Thermal Resistance junction-ambient soldered on PCB	95	90	°C/W

PIN CONNECTION

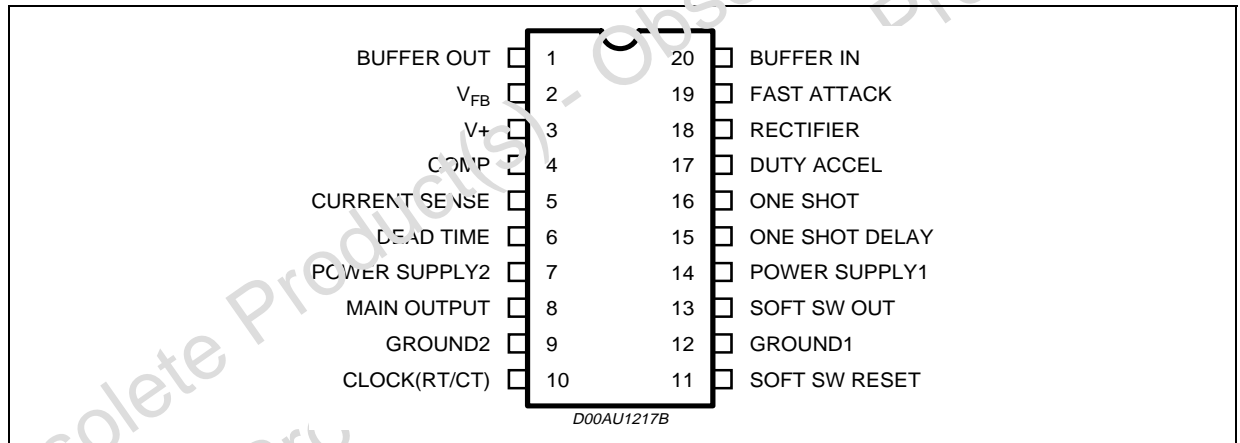

TYPICAL APPLICATION CIRCUIT

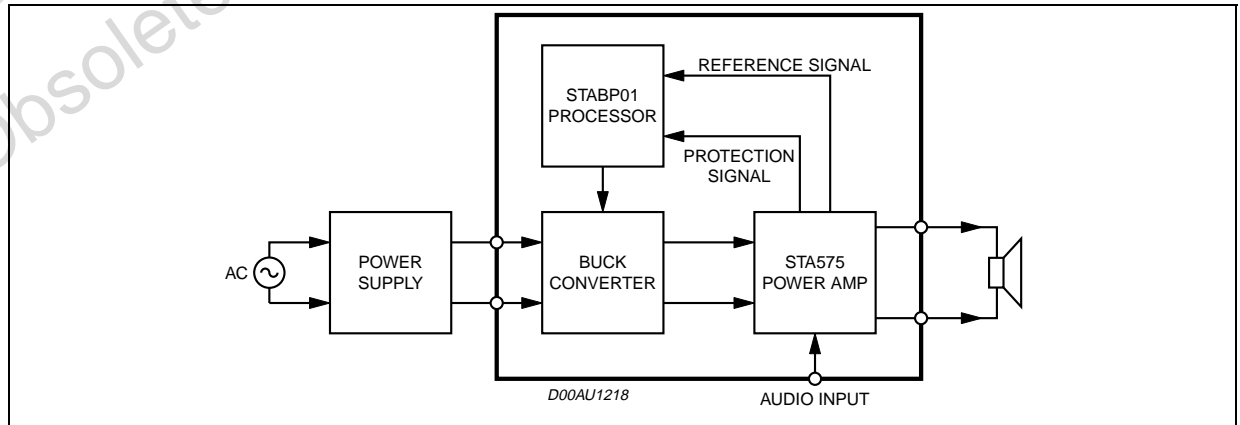

ELECTRICAL CHARACTERISTICS ($V_s = 10V$; $R_t = 22k\Omega$; $C_t = 2.2nF$; $t = 25^\circ C$ unless otherwise specified)

Symbol	Parameter	Test Conditions	Min	Typ	Max	Unit
OSCILLATOR SECTION						
fs	Initial Accuracy (*)	$T_j=25^\circ C$, SW Out Off	225	250	300	kHz
Ts	Temperature Stability	$T_{min}<T_{amb}<T_{max}$		5		%
	Amplitude	Vpin10 Peak to Peak		0.5		V
ERROR AMP SECTION						
Ib	Input Bias Current				1	μA
AVOL	Open loop Gain		65	90		dB
B	Unity Gain Bandwidth		0.7	1		MHz
SVR	Supply Voltage Rejection	$6<V_s<10V$	60	70		dB
ICMR	Input Common Mode Range				8	V
CMRR	Common Mode Rejection Ratio			90		dB
OR	Output Voltage Range	$I = 1mA$	0.5		8.5	V
CURRENT SENSE SECTION						
Gv	Gain	V_4/V_5 , $V_5 < 1V$, Duty Cycle = 80%	2.7	3	3.3	V/V
V5	Maximum Input Signal	$V_4 = 5V$	0.9	1	1.1	V
Ib	Input Bias Current	$V_5 < 0.9V$,			1	μA
Odt	Delay to Output (minimum output pulse)			150	300	ns
OUTPUT SECTION						
VOL	Output Low Level	$I_{sink}=20mA$ $I_{sink}=200mA$		0.1 1.5	0.4 2.2	V V
VOH	Output High Level	$I_{source}=20mA$ $I_{source}=200mA$	9.6 7.8	9.9 8.5		V V
tr	Rise Time	$T_j=25^\circ C$ CL=1nF		50	150	ns
tf	Fall Time	$T_j=25^\circ C$ CL=1nF		50	150	ns
UNDER-VOLTAGE LOCKOUT SECTION						
UVstart	Start Threshold		6.3	7	7.7	V
UVstop	Min Operating Voltage After Turn-on		4.5	5	5.5	V
TOTAL STANDBY CURRENT						
Ist	Start-up Current			0.5	1	mA
Is	Operating Supply Current			10	20	mA

STABP01

ELECTRICAL CHARACTERISTICS (continued)

Symbol	Parameter	Test Conditions	Min	Typ	Max	Unit
BUFFER SECTION						
I _b	Input Bias Current				1	μA
B	Unity Gain Bandwidth		0.7	1		MHz
SVR	Supply Voltage Rejection	6<V _s <10V	60	70		dB
I _{CMR}	Input Common Mode Range		0		9	V
O _R	Output Range	I = 1mA	0.5		8.5	V
SOFT SWITCH SECTION						
V _{OL}	Output Low Level	I _{sink} =20mA I _{sink} =200mA		0.1	0.4	V
				1.5	2.2	V
V _{OH}	Output High Level	I _{source} =20mA I _{source} =200mA	9.6	9.9		V
			7.3	8.5		V
t _r	Rise Time	T _j =25°C CL=1nF		50	150	ns
t _f	Fall Time	T _j =25°C CL=1nF		50	150	ns
V _{reset}	Reset Level			1		V
FAST ATTACK CONTROL SECTION						
G _{diff}	Differential Gain		16	18	20	V/V
OS _{th}	Level for one shot		0.9	1	1.1	V
OSD _{th}	Level for one shot delay		0.9	1	1.1	V
I _{15leak}	Leakage pin 15	V ₁₅ = 0.8V			0.2	μA
I _{17leak}	Leakage pin 17	V ₁₇ = 10V, V ₁₆ = 0V			0.2	μA

(*) R_t, C_t = 1% precision component

DIM.	mm			inch		
	MIN.	TYP.	MAX.	MIN.	TYP.	MAX.
a1	0.254			0.010		
B	1.39		1.65	0.055		0.065
b		0.45			0.018	
b1		0.25			0.010	
D			25.4			1.000
E		8.5			0.335	
e		2.54			0.100	
e3		22.86			0.900	
F			7.1			0.280
I			3.93			0.155
L		3.3			0.130	
Z			1.34			0.053

OUTLINE AND MECHANICAL DATA

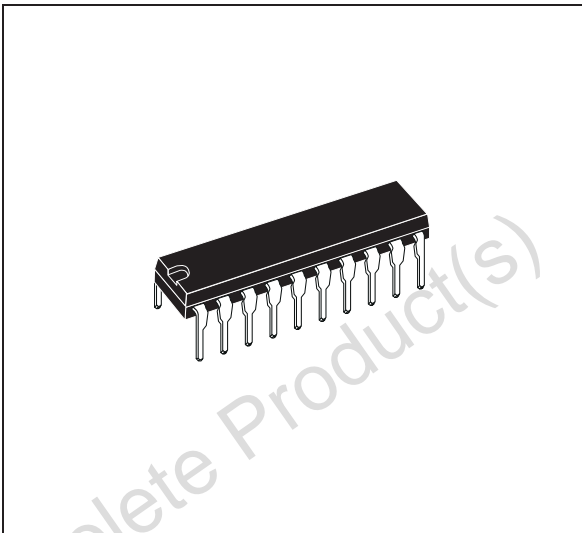

DIP20

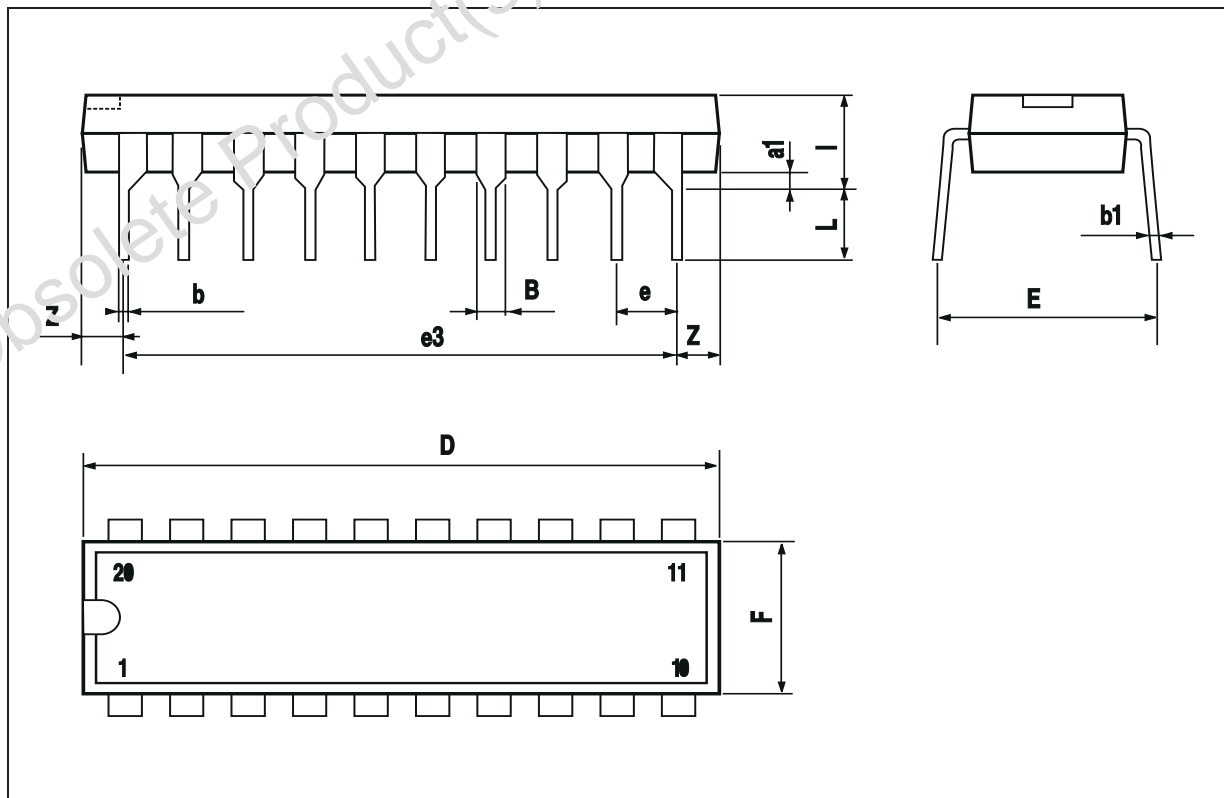

STABP01

DIM.	mm			inch		
	MIN.	TYP.	MAX.	MIN.	TYP.	MAX.
A	2.35		2.65	0.093		0.104
A1	0.1		0.3	0.004		0.012
B	0.33		0.51	0.013		0.020
C	0.23		0.32	0.009		0.013
D	12.6		13	0.496		0.512
E	7.4		7.6	0.291		0.299
e		1.27			0.050	
H	10		10.65	0.394		0.419
h	0.25		0.75	0.010		0.030
L	0.4		1.27	0.016		0.050
K	0° (min.)8° (max.)					

OUTLINE AND MECHANICAL DATA

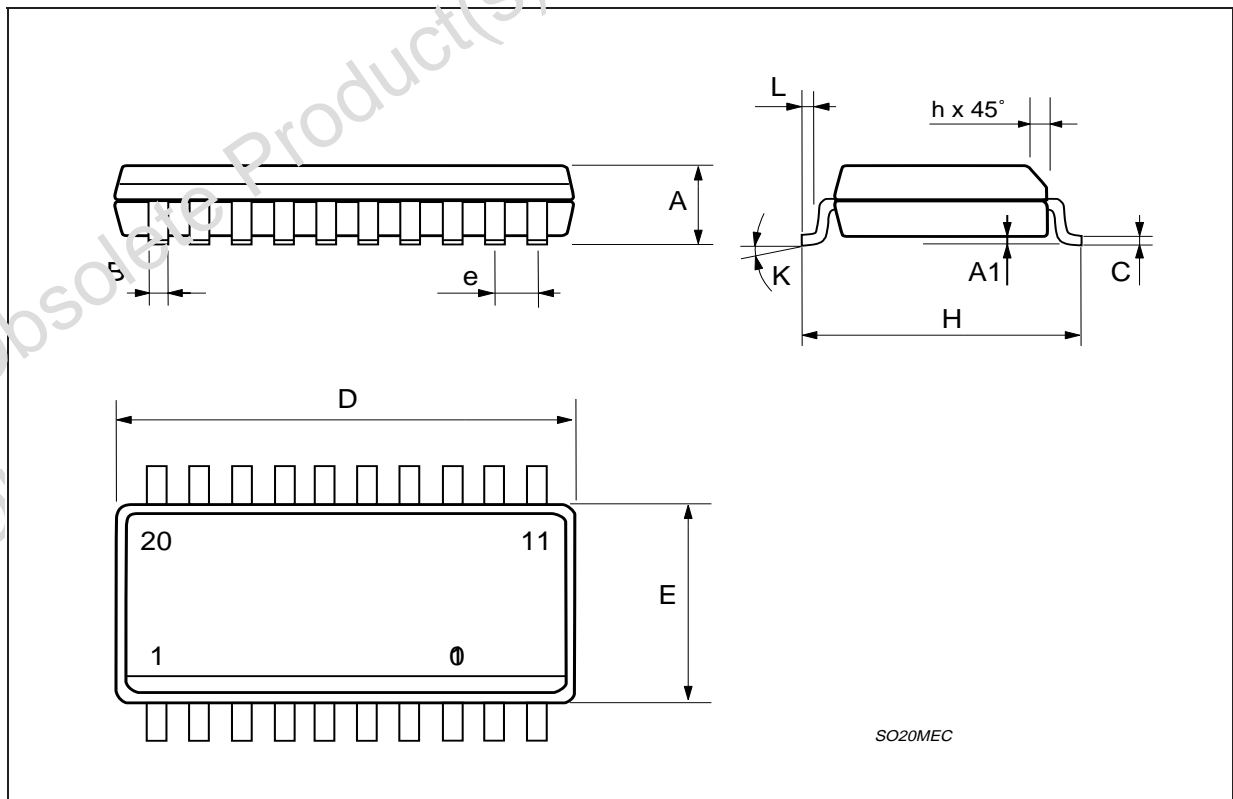
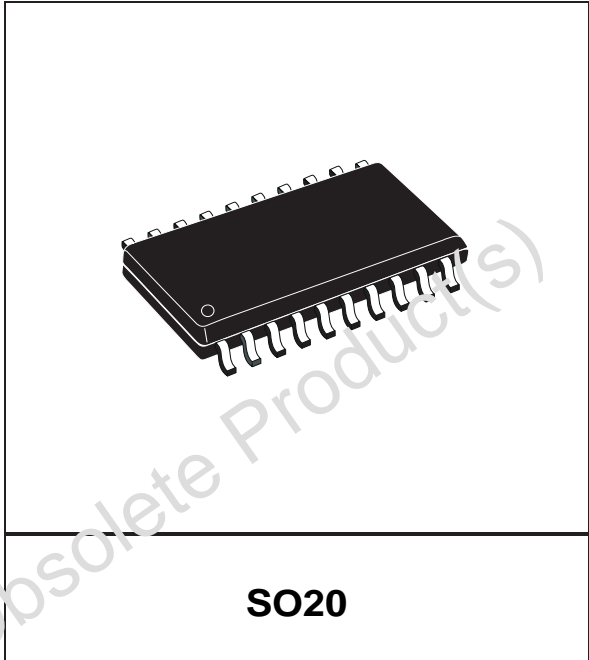

Obsolete Product(s) - Obsolete Product(s)
Obsolete Product(s) - Obsolete Product(s)

Information furnished is believed to be accurate and reliable. However, STMicroelectronics assumes no responsibility for the consequences of use of such information nor for any infringement of patents or other rights of third parties which may result from its use. No license is granted by implication or otherwise under any patent or patent rights of STMicroelectronics. Specifications mentioned in this publication are subject to change without notice. This publication supersedes and replaces all information previously supplied. STMicroelectronics products are not authorized for use as critical components in life support devices or systems without express written approval of STMicroelectronics.

The ST logo is a registered trademark of STMicroelectronics
© 2000 STMicroelectronics - All Rights Reserved

STMicroelectronics GROUP OF COMPANIES
Australia - Brazil - Canada - China - Finland - France - Germany - Hong Kong - India - Israel - Italy - Japan - Malaysia - Malta - Morocco -
Singapore - Spain - Sweden - Switzerland - United Kingdom - United States
<http://www.st.com>

Looking for pricing, stock, or lifecycle information?

Click below to explore more details on WIN SOURCE:

 [View STABP01D on WIN SOURCE](#)

 [STMicroelectronics](#) Information

Optimize Your Supply Chain with WIN SOURCE Solutions

-  Global Sourcing Solution
-  Obsolete Management
-  Cost Control Management
-  Shortage Management
-  Alternative Solution
-  Excess Inventory Management