



**THE DATASHEET OF
SN65C3221EPW**



3-V to 5.5-V Single-channel RS-232 1-Mbits Line Driver and Receiver with ± 15 -kV IEC ESD Protection

1 Features

- ESD Protection for RS-232 pins
 - ± 15 -kV Human-body model (HBM)
 - ± 8 -kV IEC 61000-4-2 Contact discharge
 - ± 15 -kV IEC 61000-4-2 Air-gap discharge
- Operate with 3-V to 5.5-V V_{CC} supply
- Operate up to 1 Mbit/s
- Low Standby Current . . . 1 μ A Typical
- External capacitors . . . $4 \times 0.1 \mu$ F
- Accepts 5-V logic input with 3.3-V supply
- RS-232 Bus-pin esd protection exceeds ± 15 kv using human-body model (HBM)
- Auto-powerdown feature automatically disables drivers for power savings

2 Applications

- [Industrial PCs](#)
- [Wired networking](#)
- [Data center and enterprise computing](#)
- [Battery-powered systems](#)
- [PDAs](#)
- [Notebooks](#)
- [Laptops](#)
- [Palmtop PCs](#)
- [Hand-held equipment](#)

3 Description

The SN65C3221E and SN75C3221E consist of one line driver, one line receiver, and a dual charge-pump circuit with ± 15 -kV IEC ESD protection pin to pin (serial-port connection pins, including GND). These devices provide the electrical interface between an asynchronous communication controller and the serial-port connector. The charge pump and four small external capacitors allow operation from a single

3-V to 5.5-V supply. These devices operate at data signaling rates up to 1 Mbit/s and a driver output slew rate of 24 V/ μ s to 150 V/ μ s.

Flexible control options for power management are available when the serial port is inactive. The auto-powerdown feature functions when FORCEON is low and FORCEOFF is high. During this mode of operation, if the devices do not sense a valid RS-232 signal on the receiver input, the driver output is disabled. If FORCEOFF is set low and \overline{EN} is high, both the driver and receiver are shut off, and the supply current is reduced to 1 μ A. Disconnecting the serial port or turning off the peripheral drivers causes the auto-powerdown condition to occur. Auto-powerdown can be disabled when FORCEON and FORCEOFF are high. With auto-powerdown enabled, the device is activated automatically when a valid signal is applied to the receiver input. The $\overline{INVALID}$ output notifies the user if an RS-232 signal is present at the receiver input. $\overline{INVALID}$ is high (valid data) if the receiver input voltage is greater than 2.7 V or less than -2.7 V, or has been between -0.3 V and 0.3 V for less than 30 μ s. $\overline{INVALID}$ is low (invalid data) if the receiver input voltage is between -0.3 V and 0.3 V for more than 30 μ s. See [Figure 8-5](#) for receiver input levels.

Device Information

PART NUMBER	PACKAGE ⁽¹⁾	BODY SIZE (NOM)
SNx5C3221E	SSOP (DB) 16	6.20 mm x 5.30 mm
	TSSOP (DW) 16	10.3 mm x 7.50 mm

(1) For all available packages, see the orderable addendum at the end of the data sheet.

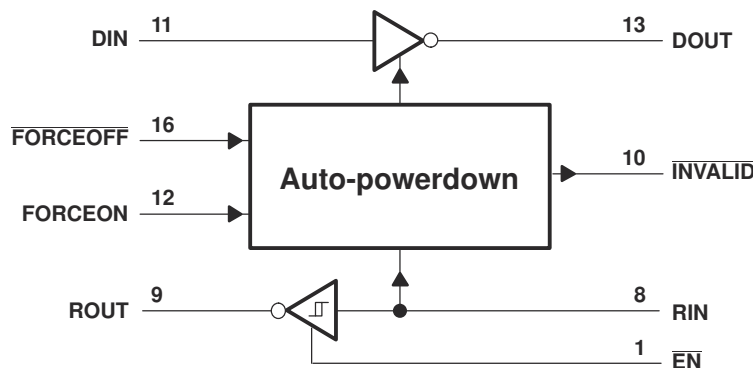

Logic Diagram (Positive Logic)



Table of Contents

1 Features	1	7.11 Auto-powerdown Section: Electrical Characteristics.....	9
2 Applications	1	7.12 Switching Characteristics: Auto-powerdown.....	9
3 Description	1	8 Parameter Measurement Information	10
4 Revision History	2	9 Detailed Description	13
5 Device Comparison Table	3	9.1 Device Functional Modes.....	13
6 Pin Configuration and Functions	4	10 Application and Implementation	14
7 Specifications	5	10.1 Application Information.....	14
7.1 Absolute Maximum Ratings.....	5	11 Device and Documentation Support	15
7.2 ESD Ratings.....	5	11.1 Receiving Notification of Documentation Updates..	15
7.3 ESD Ratings - IEC Specifications.....	5	11.2 Support Resources.....	15
7.4 Recommended Operating Conditions.....	6	11.3 Trademarks.....	15
7.5 Thermal Information.....	6	11.4 Electrostatic Discharge Caution.....	15
7.6 Electrical Characteristics.....	7	11.5 Glossary.....	15
7.7 Driver Section: Electrical Characteristics.....	7	12 Mechanical, Packaging, and Orderable Information	15
7.8 Switching Characteristics: Driver.....	7		
7.9 Receiver Section: Electrical Characteristics.....	8		
7.10 Switching Characteristics: Receiver.....	8		

4 Revision History

NOTE: Page numbers for previous revisions may differ from page numbers in the current version.

Changes from Revision B (April 2009) to Revision C (July 2021)	Page
• Changed the <i>Applications</i> list.....	1
• Deleted the Ordering Information table.....	1
• Added the <i>Device Information</i> table.....	1
• Added the <i>Pin Configuration and Functions</i>	4
• Removed the thermal information from <i>Absolute Maximum Rating</i> table and moved the thermal information to its own table.....	5
• Added a table note for PW package of SN65C3221E regarding the minimum capacitance in <i>ESD Ratings - IEC Specifications</i> table.....	5
• Changed thermal information for PW package of SN65C3221E. Added additional thermal information for other packages.....	6
• Added the <i>Detailed Description</i> section.....	13

5 Device Comparison Table

Table 5-1. 1-Mbit/s RS-232 Parts

PART NO.	TEMPERATURE RANGE	DRIVER NO.	RECEIVER NO.	ESD	SUPPLY V _{CC} (V)	FEATURE	PIN/PACKAGE
SN65C3221E	-40°C to 85°C	1	1	±15-kV Air-Gap, ±8-kV Contact, ±15-kV HBM	3.3 or 5	Auto powerdown	16-pin SOIC, SSOP, TSSOP
SN65C3232E		2	2	±15-kV Air-Gap, ±8-kV Contact, ±15-kV HBM	3.3 or 5	Low pin count	16-pin SOIC, SSOP, TSSOP
MAX3227I		1	1	±8-kV Air-Gap, ±8-kV Contact, ±15-kV HBM	3.3 or 5	Auto powerdown plus, ready signal	16-pin SSOP
SN65C3221		1	1	±15-kV HBM	3.3 or 5	Auto powerdown	16-pin SOIC, SSOP, TSSOP
SN65C3223		2	2	±15-kV HBM	3.3 or 5	Auto powerdown, enable signal	20-pin SOIC, SSOP, TSSOP
SN65C3222		2	2	±15-kV HBM	3.3 or 5	Enable, powerdown signal	20-pin SOIC, SSOP, TSSOP
SN65C3232		2	2	±15-kV HBM	3.3 or 5	Low pin count	16-pin SOIC, SSOP, TSSOP
SN65C3238		5	3	±15-kV HBM	3.3 or 5	Auto powerdown plus	28-pin SOIC, SSOP, TSSOP
SN65C3243		3	5	±15-kV HBM	3.3 or 5	Auto powerdown	28-pin SOIC, SSOP, TSSOP
SN75C3221E	0°C to 70°C	1	1	±15-kV Air-Gap, ±8-kV Contact, ±15-kV HBM	3.3 or 5	Auto powerdown	16-pin SOIC, SSOP, TSSOP
SN75C3232E		2	2	±15-kV Air-Gap, ±8-kV Contact, ±15-kV HBM	3.3 or 5	Low pin count	16-pin SOIC, SSOP, TSSOP
MAX3227C		1	1	±8-kV Air-Gap, ±8-kV Contact, ±15-kV HBM	3.3 or 5	Auto powerdown plus, ready signal	16-pin SSOP
SN75C3221		1	1	±15-kV HBM	3.3 or 5	Auto powerdown	16-pin SOIC, SSOP, TSSOP
SN75C3223		2	2	±15-kV HBM	3.5 or 5	Auto powerdown, enable signal	20-pin SOIC, SSOP, TSSOP
SN75C3222		2	2	±15-kV HBM	3.3 or 5	Enable, powerdown signal	20-pin SOIC, SSOP, TSSOP
SN75C3232		2	2	±15-kV HBM	3.3 or 5	Low pin count	16-pin SOIC, SSOP, TSSOP
SN75C3238		5	3	±15-kV HBM	3.3 or 5	Auto powerdown plus	28-pin SOIC, SSOP, TSSOP
SN75C3243		3	5	±15-kV HBM	3.3 or 5	Auto powerdown	28-pin SOIC, SSOP, TSSOP

6 Pin Configuration and Functions

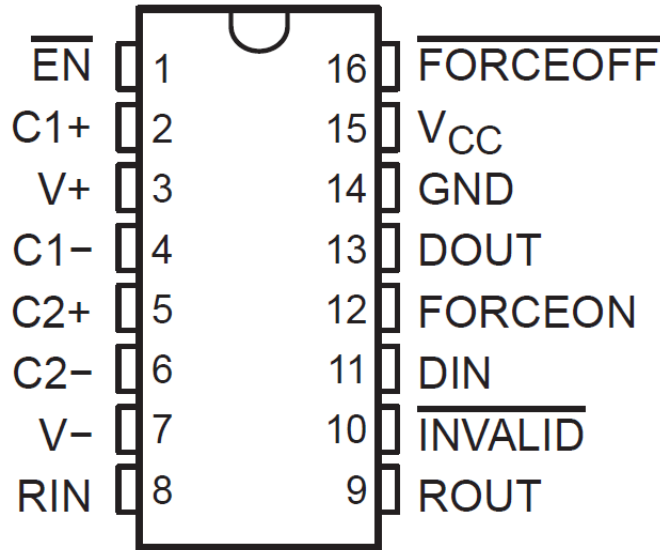

**Figure 6-1. DB or PW Package
Top View**

Table 6-1. Pin Configurations

PIN		I/O	DESCRIPTION
NAME	NO		
$\overline{\text{EN}}$	1	I	Low input enables receiver ROUT output. High input sets ROUT to high impedance.
C1+	2	—	Positive terminals of the voltage-doubler charge-pump capacitors
V+	3	O	5.5-V supply generated by the charge pump
C1-	4	—	Negative terminals of the voltage-doubler charge-pump capacitors
C2+	5	—	Positive terminals of the voltage-doubler charge-pump capacitors
C2-	6	—	Negative terminals of the voltage-doubler charge-pump capacitors
V-	7	O	-5.5-V supply generated by the charge pump
RIN	8	I	RS-232 receiver input
ROUT	9	O	Receiver output
$\overline{\text{INVALID}}$	10	O	Invalid output pin. Output low when all RIN inputs are unpowered.
DIN	11	I	Driver input
FORCEON	12	I	Automatic power-down control input
DOUT	13	O	RS-232 driver output
GND	14	—	Ground
V _{CC}	15	—	3-V to 5.5-V supply voltage
$\overline{\text{FORCEOFF}}$	16	I	Automatic power-down control input

7 Specifications

7.1 Absolute Maximum Ratings

over operating free-air temperature range (unless otherwise noted) ⁽¹⁾

		MIN	MAX	UNIT	
V _{CC}	Supply voltage range ⁽²⁾	-0.3	6	V	
V+	Positive output supply voltage range ⁽²⁾	-0.3	7	V	
V-	Negative output supply voltage range ⁽²⁾	0.3	-7	V	
V+ - V-	Supply voltage difference ⁽²⁾		13	V	
V _I	Input voltage range	Driver ($\overline{\text{FORCEOFF}}$, FORCEON, $\overline{\text{EN}}$)	-0.3	6	V
		Receiver	-25	25	
V _O	Output voltage range	Driver	-13.2	13.2	V
		Receiver ($\overline{\text{INVALID}}$)	-0.3	V _{CC} + 0.3	
T _J	Operating virtual junction temperature		150	°C	
T _{stg}	Storage temperature range	-65	150	°C	

- (1) Stresses beyond those listed under "absolute maximum ratings" may cause permanent damage to the device. These are stress ratings only, and functional operation of the device at these or any other conditions beyond those indicated under "recommended operating conditions" is not implied. Exposure to absolute-maximum-rated conditions for extended periods may affect device reliability.
- (2) All voltages are with respect to network GND.

7.2 ESD Ratings

			VALUE	UNIT	
V _(ESD)	Electrostatic discharge	Human-body model (HBM), per ANSI/ESDA/JEDEC JS-001 ⁽¹⁾	DOUT, RIN	±15000	V
			All other pins	±3000	
		Charged-device model (CDM), per JEDEC specification JESD22-C101 ⁽²⁾		±1500	

- (1) JEDEC document JEP155 states that 500-V HBM allows safe manufacturing with a standard ESD control process.
- (2) JEDEC document JEP157 states that 250-V CDM allows safe manufacturing with a standard ESD control process.

7.3 ESD Ratings - IEC Specifications

			VALUE	UNIT	
V _(ESD)	Electrostatic discharge	IEC 61000-4-2 Contact Discharge ⁽¹⁾	RIN and DOUT pins only	±8000	V
		IEC 61000-4-2 Air Discharge ⁽¹⁾	RIN and DOUT pins only	±15000	

- (1) For the PW package of SN65C3221E only, a minimum of 1-μF capacitor is required between VCC and GND to meet the specified IEC-ESD level.

7.4 Recommended Operating Conditions

See Figure 10-1. see ⁽¹⁾

			MIN	NOM	MAX	UNIT
Supply voltage		$V_{CC} = 3.3\text{ V}$	3	3.3	3.6	V
		$V_{CC} = 5\text{ V}$	4.5	5	5.5	
V_{IH}	Driver and control high-level input voltage	DIN, FORCEOFF, FORCEON, EN	$V_{CC} = 3.3\text{ V}$	2		V
			$V_{CC} = 5\text{ V}$	2.4		
V_{IL}	Driver and control low-level input voltage	DIN, FORCEOFF, FORCEON, EN			0.8	V
V_I	Driver and control input voltage	DIN, FORCEOFF, FORCEON	0		5.5	V
V_I	Receiver input voltage		-25		25	V
T_A	Operating free-air temperature	SN65C3221E	-40		85	°C
		SN75C3221E	0		70	

(1) Test conditions are C1–C4 = 0.1 μF at $V_{CC} = 3.3\text{ V} \pm 0.3\text{ V}$; C1 = 0.047 μF , C2–C4 = 0.33 μF at $V_{CC} = 5\text{ V} \pm 0.5\text{ V}$.

7.5 Thermal Information

THERMAL METRIC ¹		SN65C3221E		SN75C3221E		UNIT
		PW (TSSOP)	DB (SSOP)	PW (TSSOP)	DB (SSOP)	
		16 PINS	16 PINS	16 PINS	16 PINS	
$R_{\theta JA}$	Junction-to-ambient thermal resistance	110.9	82	108	82	°C/W
$R_{\theta JC(top)}$	Junction-to-case (top) thermal resistance	41.7	45.7	41.1	45.7	°C/W
$R_{\theta JB}$	Junction-to-board thermal resistance	57.2	44.4	51.4	44.4	°C/W
Ψ_{JT}	Junction-to-top characterization parameter	4.2	11.0	3.9	11.0	°C/W
Ψ_{JB}	Junction-to-board characterization parameter	56.6	43.8	50.9	43.8	°C/W

7.6 Electrical Characteristics

over recommended ranges of supply voltage and operating free-air temperature (unless otherwise noted) (see [Figure 10-1](#))

PARAMETER		TEST CONDITIONS ⁽¹⁾	MIN	TYP ⁽²⁾	MAX	UNIT
I_I	Input leakage current	FORCEOFF, FORCEON, \overline{EN}		±0.01	±1	μA
I_{CC}	Supply current ($T_A = 25^\circ\text{C}$)	Auto-powerdown disabled	No load, FORCEOFF and FORCEON at V_{CC}	0.3	1	mA
		Powered off	No load, FORCEOFF at GND	1	10	μA
		Auto-powerdown enabled	No load, FORCEOFF at V_{CC} , FORCEON at GND, All RIN are open or grounded	1	10	

- (1) Test conditions are $C1-C4 = 0.1 \mu\text{F}$ at $V_{CC} = 3.3 \text{ V} \pm 0.3 \text{ V}$; $C1 = 0.047 \mu\text{F}$, $C2-C4 = 0.33 \mu\text{F}$ at $V_{CC} = 5 \text{ V} \pm 0.5 \text{ V}$.
(2) All typical values are at $V_{CC} = 3.3 \text{ V}$ or $V_{CC} = 5 \text{ V}$, and $T_A = 25^\circ\text{C}$.

7.7 Driver Section: Electrical Characteristics

over recommended ranges of supply voltage and operating free-air temperature (unless otherwise noted) (see [Figure 10-1](#))

PARAMETER		TEST CONDITIONS ⁽¹⁾	MIN	TYP ⁽²⁾	MAX	UNIT
V_{OH}	High-level output voltage	DOUT at $R_L = 3 \text{ k}\Omega$ to GND, $DIN = \text{GND}$	5	5.4		V
V_{OL}	Low-level output voltage	DOUT at $R_L = 3 \text{ k}\Omega$ to GND, $DIN = V_{CC}$	-5	-5.4		V
I_{IH}	High-level input current	$V_I = V_{CC}$		±0.01	±1	μA
I_{IL}	Low-level input current	V_I at GND		±0.01	±1	μA
I_{OS}	Short-circuit output current ⁽³⁾	$V_{CC} = 3.6 \text{ V}$, $V_O = 0 \text{ V}$		±35	±60	mA
		$V_{CC} = 5.5 \text{ V}$, $V_O = 0 \text{ V}$		±35	±90	
r_o	Output resistance	V_{CC} , $V+$, and $V- = 0 \text{ V}$, $V_O = \pm 2 \text{ V}$	300	10M		Ω
I_{off}	Output leakage current	FORCEOFF = GND	$V_O = \pm 12 \text{ V}$, $V_{CC} = 3 \text{ V to } 3.6 \text{ V}$		±25	μA
			$V_O = \pm 10 \text{ V}$, $V_{CC} = 4.5 \text{ V to } 5.5 \text{ V}$		±25	

- (1) Test conditions are $C1-C4 = 0.1 \mu\text{F}$ at $V_{CC} = 3.3 \text{ V} \pm 0.3 \text{ V}$; $C1 = 0.047 \mu\text{F}$, $C2-C4 = 0.33 \mu\text{F}$ at $V_{CC} = 5 \text{ V} \pm 0.5 \text{ V}$.
(2) All typical values are at $V_{CC} = 3.3 \text{ V}$ or $V_{CC} = 5 \text{ V}$, and $T_A = 25^\circ\text{C}$.
(3) Short-circuit durations should be controlled to prevent exceeding the device absolute power-dissipation ratings, and not more than one output should be shorted at a time.

7.8 Switching Characteristics: Driver

over recommended ranges of supply voltage and operating free-air temperature (unless otherwise noted) (see [Figure 10-1](#))

PARAMETER		TEST CONDITIONS ⁽¹⁾	MIN	TYP ⁽²⁾	MAX	UNIT
Maximum data rate (see Figure 8-1)	$R_L = 3 \text{ k}\Omega$	$C_L = 1000 \text{ pF}$		250		kbit/s
		$C_L = 250 \text{ pF}$, $V_{CC} = 3 \text{ V to } 4.5 \text{ V}$		1000		
		$C_L = 1000 \text{ pF}$, $V_{CC} = 4.5 \text{ V to } 5.5 \text{ V}$		1000		
$t_{sk(p)}$	Pulse skew ⁽³⁾	$C_L = 150 \text{ pF to } 2500 \text{ pF}$, $R_L = 3 \text{ k}\Omega$ to $7 \text{ k}\Omega$, See Figure 8-2		100		ns
SR(tr)	Slew rate, transition region (see Figure 8-1)	$V_{CC} = 3.3 \text{ V}$, $R_L = 3 \text{ k}\Omega$ to $7 \text{ k}\Omega$, $C_L = 150 \text{ pF to } 1000 \text{ pF}$		18	150	V/μs

- (1) Test conditions are $C1-C4 = 0.1 \mu\text{F}$ at $V_{CC} = 3.3 \text{ V} \pm 0.3 \text{ V}$; $C1 = 0.047 \mu\text{F}$, $C2-C4 = 0.33 \mu\text{F}$ at $V_{CC} = 5 \text{ V} \pm 0.5 \text{ V}$.
(2) All typical values are at $V_{CC} = 3.3 \text{ V}$ or $V_{CC} = 5 \text{ V}$, and $T_A = 25^\circ\text{C}$.
(3) Pulse skew is defined as $|t_{PLH} - t_{PHL}|$ of each channel of the same device.

7.9 Receiver Section: Electrical Characteristics

over recommended ranges of supply voltage and operating free-air temperature (unless otherwise noted) (see [Figure 10-1](#))

PARAMETER		TEST CONDITIONS ⁽¹⁾	MIN	TYP ⁽²⁾	MAX	UNIT
V _{OH}	High-level output voltage	I _{OH} = -1 mA	V _{CC} - 0.6 V	V _{CC} - 0.1 V		V
V _{OL}	Low-level output voltage	I _{OL} = 1.6 mA			0.4	V
V _{IT+}	Positive-going input threshold voltage	V _{CC} = 3.3 V		1.6	2.4	V
		V _{CC} = 5 V		1.9	2.4	
V _{IT-}	Negative-going input threshold voltage	V _{CC} = 3.3 V	0.6	1.1		V
		V _{CC} = 5 V	0.8	1.4		
V _{hys}	Input hysteresis (V _{IT+} - V _{IT-})			0.5		V
I _{off}	Output leakage current	FORCEOFF = 0 V		±0.05	±10	µA
r _i	Input resistance	V _i = ±3 V to ±25 V	3	5	7	kΩ

(1) Test conditions are C1–C4 = 0.1 µF at V_{CC} = 3.3 V ± 0.3 V; C1 = 0.047 µF, C2–C4 = 0.33 µF at V_{CC} = 5 V ± 0.5 V.

(2) All typical values are at V_{CC} = 3.3 V or V_{CC} = 5 V, and T_A = 25°C.

7.10 Switching Characteristics: Receiver

over recommended ranges of supply voltage and operating free-air temperature (unless otherwise noted) (see [Figure 10-1](#))

PARAMETER		TEST CONDITIONS ⁽¹⁾	TYP ⁽²⁾	UNIT
t _{PLH}	Propagation delay time, low- to high-level output	C _L = 150 pF, See Figure 8-3	150	ns
t _{PHL}	Propagation delay time, high- to low-level output	C _L = 150 pF, See Figure 8-3	150	ns
t _{en}	Output enable time	C _L = 150 pF, R _L = 3 kΩ, See Figure 8-4	200	ns
t _{dis}	Output disable time	C _L = 150 pF, R _L = 3 kΩ, See Figure 8-4	200	ns
t _{sk(p)}	Pulse skew ⁽³⁾	See Figure 8-3	50	ns

(1) Test conditions are C1–C4 = 0.1 µF at V_{CC} = 3.3 V ± 0.3 V; C1 = 0.047 µF, C2–C4 = 0.33 µF at V_{CC} = 5 V ± 0.5 V.

(2) All typical values are at V_{CC} = 3.3 V or V_{CC} = 5 V, and T_A = 25°C.

(3) Pulse skew is defined as |t_{PLH} - t_{PHL}| of each channel of the same device.

7.11 Auto-powerdown Section: Electrical Characteristics

over recommended ranges of supply voltage and operating free-air temperature (unless otherwise noted) (see [Figure 8-5](#))

PARAMETER		TEST CONDITIONS	MIN	MAX	UNIT
$V_{T+(valid)}$	Receiver input threshold for $\overline{INVALID}$ high-level output voltage	FORCEON = GND, $\overline{FORCEOFF} = V_{CC}$		2.7	V
$V_{T-(valid)}$	Receiver input threshold for $\overline{INVALID}$ high-level output voltage	FORCEON = GND, $\overline{FORCEOFF} = V_{CC}$	-2.7		V
$V_{T(invalid)}$	Receiver input threshold for $\overline{INVALID}$ low-level output voltage	FORCEON = GND, $\overline{FORCEOFF} = V_{CC}$	-0.3	0.3	V
V_{OH}	$\overline{INVALID}$ high-level output voltage	$I_{OH} = -1$ mA, FORCEON = GND, $\overline{FORCEOFF} = V_{CC}$	$V_{CC} - 0.6$		V
V_{OL}	$\overline{INVALID}$ low-level output voltage	$I_{OL} = 1.6$ mA, FORCEON = GND, $\overline{FORCEOFF} = V_{CC}$		0.4	V

7.12 Switching Characteristics: Auto-powerdown

over recommended ranges of supply voltage and operating free-air temperature (unless otherwise noted) (see [Figure 8-5](#))

PARAMETER		TYP ⁽¹⁾	UNIT
t_{valid}	Propagation delay time, low- to high-level output	1	μ s
$t_{invalid}$	Propagation delay time, high- to low-level output	30	μ s
t_{en}	Supply enable time	100	μ s

(1) All typical values are at $V_{CC} = 3.3$ V or $V_{CC} = 5$ V, and $T_A = 25^\circ\text{C}$.

8 Parameter Measurement Information

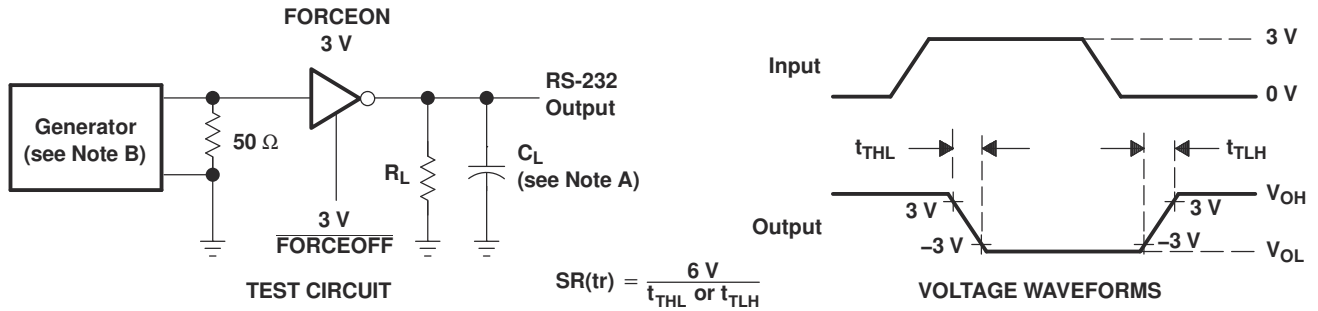

- NOTES: A. C_L includes probe and jig capacitance.
 B. The pulse generator has the following characteristics: PRR = 250 kbit/s, $Z_0 = 50\ \Omega$, 50% duty cycle, $t_r \leq 10\text{ ns}$, $t_f \leq 10\text{ ns}$.

Figure 8-1. Driver Slew Rate

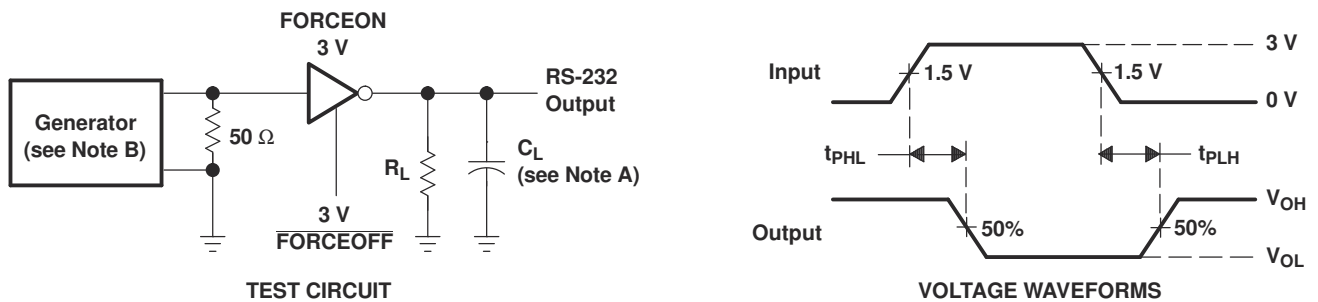

- NOTES: A. C_L includes probe and jig capacitance.
 B. The pulse generator has the following characteristics: PRR = 250 kbit/s, $Z_0 = 50\ \Omega$, 50% duty cycle, $t_r \leq 10\text{ ns}$, $t_f \leq 10\text{ ns}$.

Figure 8-2. Driver Pulse Skew

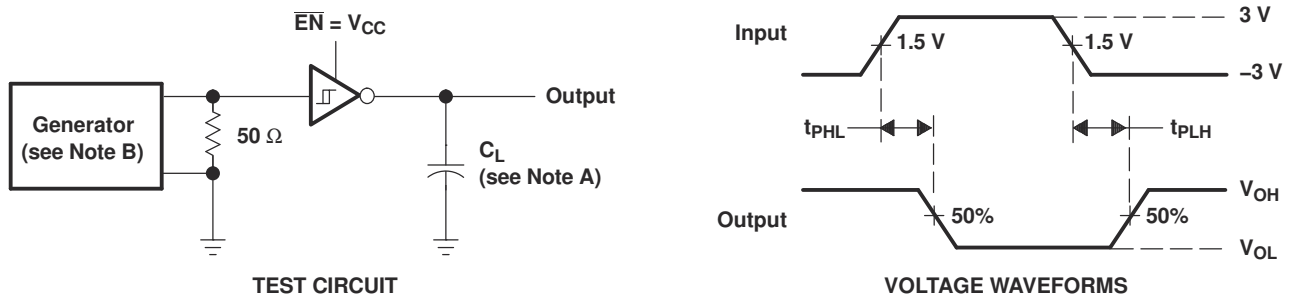

- NOTES: A. C_L includes probe and jig capacitance.
 B. The pulse generator has the following characteristics: $Z_0 = 50\ \Omega$, 50% duty cycle, $t_r \leq 10\text{ ns}$, $t_f \leq 10\text{ ns}$.

Figure 8-3. Receiver Propagation Delay Times

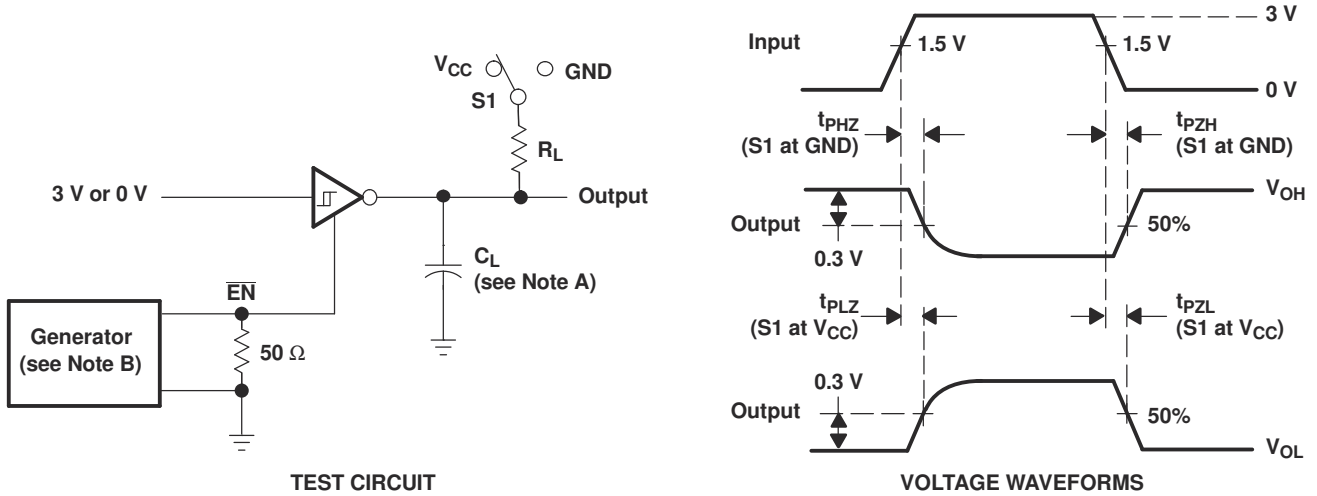

- NOTES:
- A. C_L includes probe and jig capacitance.
 - B. The pulse generator has the following characteristics: $Z_O = 50 \Omega$, 50% duty cycle, $t_r \leq 10 \text{ ns}$, $t_f \leq 10 \text{ ns}$.
 - C. t_{PLZ} and t_{PHZ} are the same as t_{dis} .
 - D. t_{PZL} and t_{PZH} are the same as t_{en} .

Figure 8-4. Receiver Enable and Disable Times

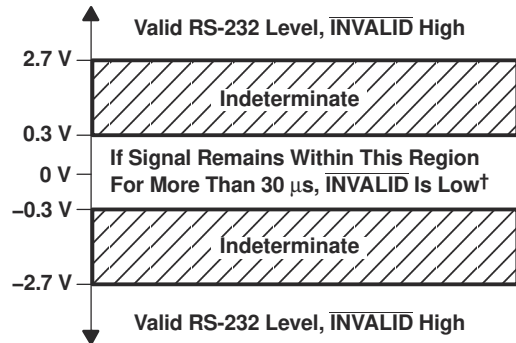
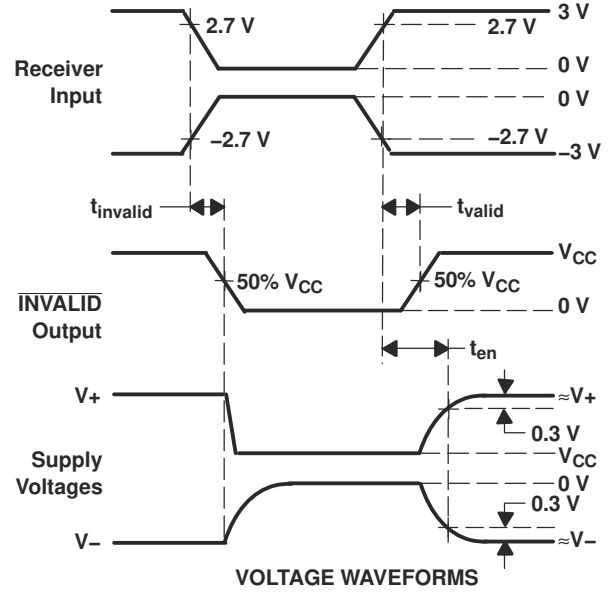
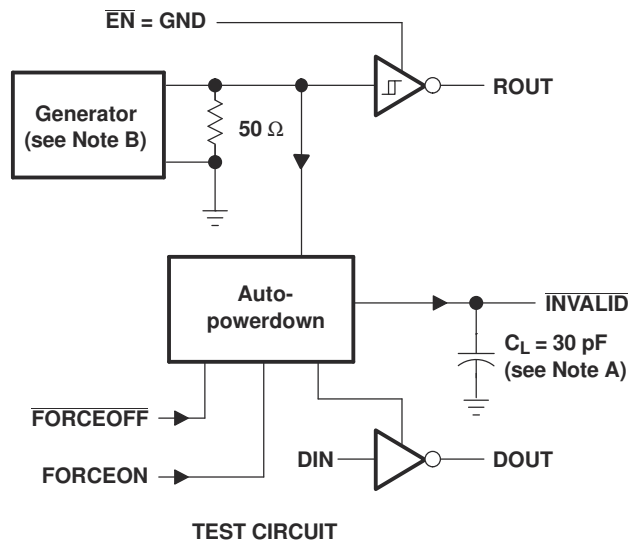

† Auto-powerdown disables drivers and reduces supply current to 1 μA.

NOTES: A. C_L includes probe and jig capacitance.

B. The pulse generator has the following characteristics: PRR = 5 kbit/s, $Z_O = 50 \Omega$, 50% duty cycle, $t_r \leq 10 \text{ ns}$, $t_f \leq 10 \text{ ns}$.

Figure 8-5. $\overline{INVALID}$ Propagation Delay Times and Driver Enabling Time

9 Detailed Description

9.1 Device Functional Modes

Table 9-1. Each Driver

INPUTS ⁽¹⁾				OUTPUT DOUT	DRIVER STATUS
DIN	FORCEON	FORCEOFF	VALID RIN RS-232 LEVEL		
X	X	L	X	Z	Powered off
L	H	H	X	H	Normal operation with auto-powerdown disabled
H	H	H	X	L	
L	L	H	Yes	H	Normal operation with auto-powerdown enabled
H	L	H	Yes	L	
L	L	H	No	Z	Powered off by auto-powerdown feature
H	L	H	No	Z	

(1) H = high level, L = low level, X = irrelevant, Z = high impedance

Table 9-2. Each Receiver

INPUTS ⁽¹⁾			OUTPUT ROUT
RIN	$\overline{\text{EN}}$	VALID RIN RS-232 LEVEL	
L	L	X	H
H	L	X	L
X	H	X	Z
Open	L	No	H

(1) H = high level, L = low level, X = irrelevant, Z = high impedance (off), Open = disconnected input or connected driver off

10 Application and Implementation

Note

Information in the following applications sections is not part of the TI component specification, and TI does not warrant its accuracy or completeness. TI's customers are responsible for determining suitability of components for their purposes, as well as validating and testing their design implementation to confirm system functionality.

10.1 Application Information

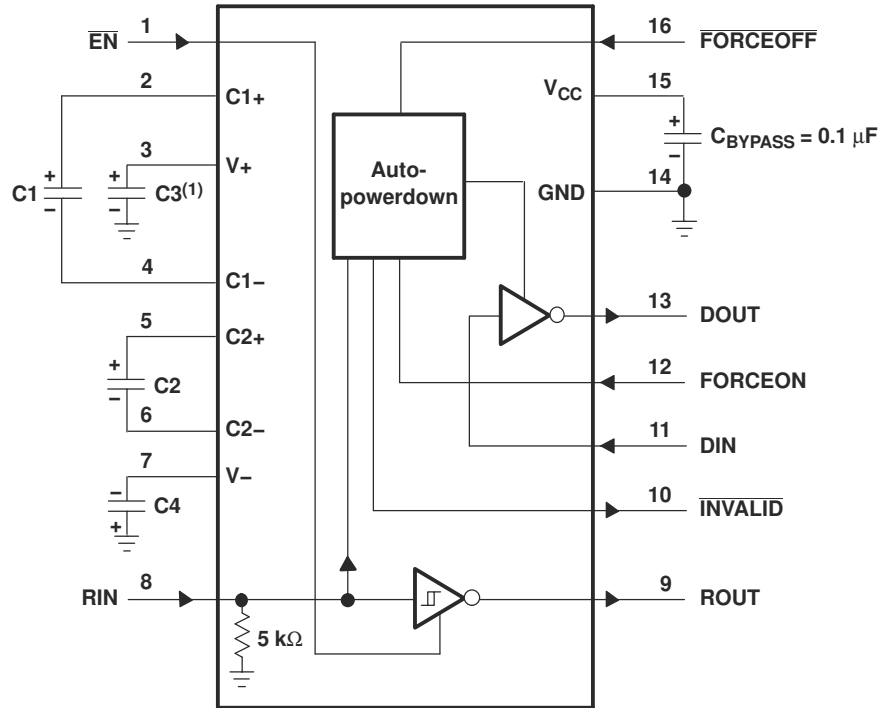

(1) C3 can be connected to V_{CC} or GND.

NOTES: A. Resistor values shown are nominal.

B. Nonpolarized ceramic capacitors are acceptable. If polarized tantalum or electrolytic capacitors are used, they should be connected as shown.

V_{CC} vs CAPACITOR VALUES

V_{CC}	C1	C2, C3, and C4
3.3 V \pm 0.3 V	0.1 μ F	0.1 μ F
5 V \pm 0.5 V	0.047 μ F	0.33 μ F
3 V to 5.5 V	0.1 μ F	0.47 μ F

Figure 10-1. Typical Operating Circuit and Capacitor Values

11 Device and Documentation Support

TI offers an extensive line of development tools. Tools and software to evaluate the performance of the device, generate code, and develop solutions are listed below.

11.1 Receiving Notification of Documentation Updates

To receive notification of documentation updates, navigate to the device product folder on ti.com. Click on *Subscribe to updates* to register and receive a weekly digest of any product information that has changed. For change details, review the revision history included in any revised document.

11.2 Support Resources

[TI E2E™ support forums](#) are an engineer's go-to source for fast, verified answers and design help — straight from the experts. Search existing answers or ask your own question to get the quick design help you need.

Linked content is provided "AS IS" by the respective contributors. They do not constitute TI specifications and do not necessarily reflect TI's views; see TI's [Terms of Use](#).

11.3 Trademarks

TI E2E™ is a trademark of Texas Instruments.
All trademarks are the property of their respective owners.

11.4 Electrostatic Discharge Caution



This integrated circuit can be damaged by ESD. Texas Instruments recommends that all integrated circuits be handled with appropriate precautions. Failure to observe proper handling and installation procedures can cause damage.

ESD damage can range from subtle performance degradation to complete device failure. Precision integrated circuits may be more susceptible to damage because very small parametric changes could cause the device not to meet its published specifications.

11.5 Glossary

[TI Glossary](#) This glossary lists and explains terms, acronyms, and definitions.

12 Mechanical, Packaging, and Orderable Information

The following pages include mechanical, packaging, and orderable information. This information is the most current data available for the designated devices. This data is subject to change without notice and revision of this document. For browser-based versions of this data sheet, refer to the left-hand navigation.

PACKAGING INFORMATION

Orderable Device	Status (1)	Package Type	Package Drawing	Pins	Package Qty	Eco Plan (2)	Lead finish/ Ball material (6)	MSL Peak Temp (3)	Op Temp (°C)	Device Marking (4/5)	Samples
SN65C3221EDBR	ACTIVE	SSOP	DB	16	2000	RoHS & Green	NIPDAU	Level-1-260C-UNLIM	-40 to 85	MU221E	Samples
SN65C3221EPWR	ACTIVE	TSSOP	PW	16	2000	RoHS & Green	NIPDAU	Level-1-260C-UNLIM	-40 to 85	MU221E	Samples

(1) The marketing status values are defined as follows:

ACTIVE: Product device recommended for new designs.

LIFEBUY: TI has announced that the device will be discontinued, and a lifetime-buy period is in effect.

NRND: Not recommended for new designs. Device is in production to support existing customers, but TI does not recommend using this part in a new design.

PREVIEW: Device has been announced but is not in production. Samples may or may not be available.

OBsolete: TI has discontinued the production of the device.

(2) **RoHS:** TI defines "RoHS" to mean semiconductor products that are compliant with the current EU RoHS requirements for all 10 RoHS substances, including the requirement that RoHS substance do not exceed 0.1% by weight in homogeneous materials. Where designed to be soldered at high temperatures, "RoHS" products are suitable for use in specified lead-free processes. TI may reference these types of products as "Pb-Free".

RoHS Exempt: TI defines "RoHS Exempt" to mean products that contain lead but are compliant with EU RoHS pursuant to a specific EU RoHS exemption.

Green: TI defines "Green" to mean the content of Chlorine (Cl) and Bromine (Br) based flame retardants meet JS709B low halogen requirements of <=1000ppm threshold. Antimony trioxide based flame retardants must also meet the <=1000ppm threshold requirement.

(3) MSL, Peak Temp. - The Moisture Sensitivity Level rating according to the JEDEC industry standard classifications, and peak solder temperature.

(4) There may be additional marking, which relates to the logo, the lot trace code information, or the environmental category on the device.

(5) Multiple Device Markings will be inside parentheses. Only one Device Marking contained in parentheses and separated by a "~" will appear on a device. If a line is indented then it is a continuation of the previous line and the two combined represent the entire Device Marking for that device.

(6) Lead finish/Ball material - Orderable Devices may have multiple material finish options. Finish options are separated by a vertical ruled line. Lead finish/Ball material values may wrap to two lines if the finish value exceeds the maximum column width.

Important Information and Disclaimer:The information provided on this page represents TI's knowledge and belief as of the date that it is provided. TI bases its knowledge and belief on information provided by third parties, and makes no representation or warranty as to the accuracy of such information. Efforts are underway to better integrate information from third parties. TI has taken and continues to take reasonable steps to provide representative and accurate information but may not have conducted destructive testing or chemical analysis on incoming materials and chemicals. TI and TI suppliers consider certain information to be proprietary, and thus CAS numbers and other limited information may not be available for release.

In no event shall TI's liability arising out of such information exceed the total purchase price of the TI part(s) at issue in this document sold by TI to Customer on an annual basis.

TAPE AND REEL INFORMATION

QUADRANT ASSIGNMENTS FOR PIN 1 ORIENTATION IN TAPE

*All dimensions are nominal

Device	Package Type	Package Drawing	Pins	SPQ	Reel Diameter (mm)	Reel Width W1 (mm)	A0 (mm)	B0 (mm)	K0 (mm)	P1 (mm)	W (mm)	Pin1 Quadrant
SN65C3221EDBR	SSOP	DB	16	2000	330.0	16.4	8.35	6.6	2.4	12.0	16.0	Q1
SN65C3221EPWR	TSSOP	PW	16	2000	330.0	12.4	6.9	5.6	1.6	8.0	12.0	Q1

TAPE AND REEL BOX DIMENSIONS

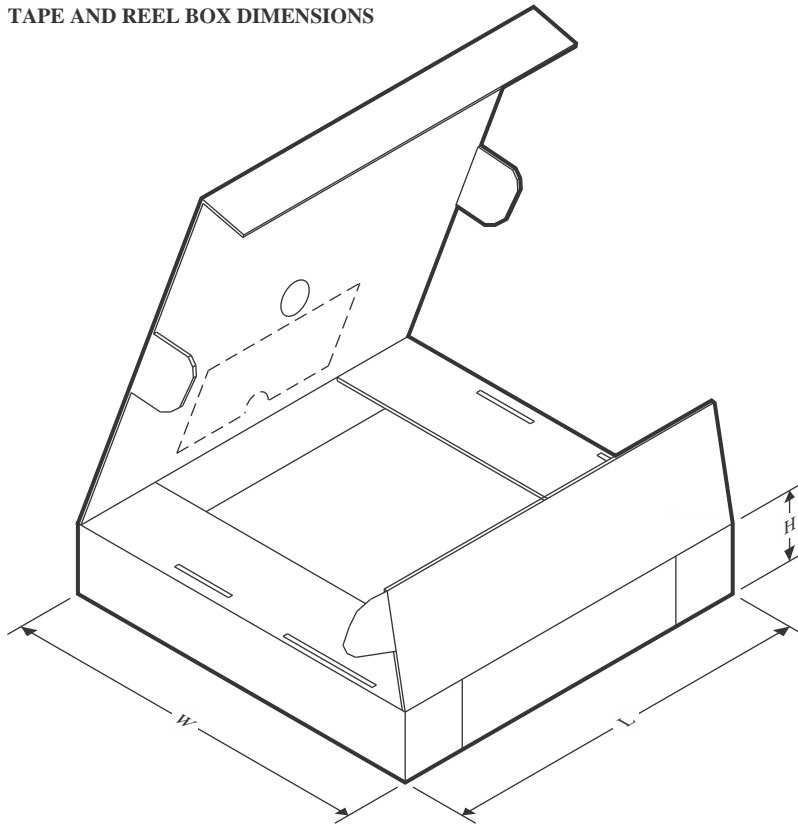

*All dimensions are nominal

Device	Package Type	Package Drawing	Pins	SPQ	Length (mm)	Width (mm)	Height (mm)
SN65C3221EDBR	SSOP	DB	16	2000	356.0	356.0	35.0
SN65C3221EPWR	TSSOP	PW	16	2000	356.0	356.0	35.0



4220204/A 02/2017

NOTES:

1. All linear dimensions are in millimeters. Any dimensions in parenthesis are for reference only. Dimensioning and tolerancing per ASME Y14.5M.
2. This drawing is subject to change without notice.
3. This dimension does not include mold flash, protrusions, or gate burrs. Mold flash, protrusions, or gate burrs shall not exceed 0.15 mm per side.
4. This dimension does not include interlead flash. Interlead flash shall not exceed 0.25 mm per side.
5. Reference JEDEC registration MO-153.

EXAMPLE BOARD LAYOUT

PW0016A

TSSOP - 1.2 mm max height

SMALL OUTLINE PACKAGE



LAND PATTERN EXAMPLE
EXPOSED METAL SHOWN
SCALE: 10X



4220204/A 02/2017

NOTES: (continued)

- 6. Publication IPC-7351 may have alternate designs.
- 7. Solder mask tolerances between and around signal pads can vary based on board fabrication site.

EXAMPLE STENCIL DESIGN

PW0016A

TSSOP - 1.2 mm max height

SMALL OUTLINE PACKAGE



SOLDER PASTE EXAMPLE
BASED ON 0.125 mm THICK STENCIL
SCALE: 10X

4220204/A 02/2017

NOTES: (continued)

8. Laser cutting apertures with trapezoidal walls and rounded corners may offer better paste release. IPC-7525 may have alternate design recommendations.
9. Board assembly site may have different recommendations for stencil design.

DB0016A



PACKAGE OUTLINE

SSOP - 2 mm max height

SMALL OUTLINE PACKAGE



NOTES:

1. All linear dimensions are in millimeters. Any dimensions in parenthesis are for reference only. Dimensioning and tolerancing per ASME Y14.5M.
2. This drawing is subject to change without notice.
3. This dimension does not include mold flash, protrusions, or gate burrs. Mold flash, protrusions, or gate burrs shall not exceed 0.15 mm per side.
4. Reference JEDEC registration MO-150.

EXAMPLE BOARD LAYOUT

DB0016A

SSOP - 2 mm max height

SMALL OUTLINE PACKAGE



LAND PATTERN EXAMPLE
EXPOSED METAL SHOWN
SCALE: 10X



4220763/A 05/2022

NOTES: (continued)

- 5. Publication IPC-7351 may have alternate designs.
- 6. Solder mask tolerances between and around signal pads can vary based on board fabrication site.

EXAMPLE STENCIL DESIGN

DB0016A

SSOP - 2 mm max height

SMALL OUTLINE PACKAGE



SOLDER PASTE EXAMPLE
BASED ON 0.125 mm THICK STENCIL
SCALE: 10X

4220763/A 05/2022

NOTES: (continued)

7. Laser cutting apertures with trapezoidal walls and rounded corners may offer better paste release. IPC-7525 may have alternate design recommendations.
8. Board assembly site may have different recommendations for stencil design.

IMPORTANT NOTICE AND DISCLAIMER

TI PROVIDES TECHNICAL AND RELIABILITY DATA (INCLUDING DATA SHEETS), DESIGN RESOURCES (INCLUDING REFERENCE DESIGNS), APPLICATION OR OTHER DESIGN ADVICE, WEB TOOLS, SAFETY INFORMATION, AND OTHER RESOURCES "AS IS" AND WITH ALL FAULTS, AND DISCLAIMS ALL WARRANTIES, EXPRESS AND IMPLIED, INCLUDING WITHOUT LIMITATION ANY IMPLIED WARRANTIES OF MERCHANTABILITY, FITNESS FOR A PARTICULAR PURPOSE OR NON-INFRINGEMENT OF THIRD PARTY INTELLECTUAL PROPERTY RIGHTS.

These resources are intended for skilled developers designing with TI products. You are solely responsible for (1) selecting the appropriate TI products for your application, (2) designing, validating and testing your application, and (3) ensuring your application meets applicable standards, and any other safety, security, regulatory or other requirements.

These resources are subject to change without notice. TI grants you permission to use these resources only for development of an application that uses the TI products described in the resource. Other reproduction and display of these resources is prohibited. No license is granted to any other TI intellectual property right or to any third party intellectual property right. TI disclaims responsibility for, and you will fully indemnify TI and its representatives against, any claims, damages, costs, losses, and liabilities arising out of your use of these resources.

TI's products are provided subject to [TI's Terms of Sale](#) or other applicable terms available either on [ti.com](https://www.ti.com) or provided in conjunction with such TI products. TI's provision of these resources does not expand or otherwise alter TI's applicable warranties or warranty disclaimers for TI products.

TI objects to and rejects any additional or different terms you may have proposed.

Mailing Address: Texas Instruments, Post Office Box 655303, Dallas, Texas 75265
Copyright © 2024, Texas Instruments Incorporated

Looking for pricing, stock, or lifecycle information?

Click below to explore more details on WIN SOURCE:

 [View SN65C3221EPW on WIN SOURCE](#)

 [Texas Instruments](#) Information

Optimize Your Supply Chain with WIN SOURCE Solutions

-  Global Sourcing Solution
-  Obsolete Management
-  Cost Control Management
-  Shortage Management
-  Alternative Solution
-  Excess Inventory Management