



**THE DATASHEET OF
SN54LS73AJ**



SN5473, SN54LS73A, SN7473, SN74LS73A DUAL J-K FLIP-FLOPS WITH CLEAR

SDLS118 – DECEMBER 1983 – REVISED MARCH 1988

- Package Options Include Plastic "Small Outline" Packages, Flat Packages, and Plastic and Ceramic DIPs
- Dependable Texas Instruments Quality and Reliability

description

The '73, and 'H73, contain two independent J-K flip-flops with individual J-K, clock, and direct clear inputs. The '73, and 'H73, are positive pulse-triggered flip-flops. J-K input is loaded into the master while the clock is high and transferred to the slave on the high-to-low transition. For these devices the J and K inputs must be stable while the clock is high.

The 'LS73A contains two independent negative-edge-triggered flip-flops. The J and K inputs must be stable one setup time prior to the high-to-low clock transition for predictable operation. When the clear is low, it overrides the clock and data inputs forcing the Q output low and the \bar{Q} output high.

The SN5473, SN54H73, and the SN54LS73A are characterized for operation over the full military temperature range of -55°C to 125°C . The SN7473, and the SN74LS73A are characterized for operation from 0°C to 70°C .

SN5473, SN54LS73A . . . J OR W PACKAGE
SN7473 . . . N PACKAGE
SN74LS73A . . . D OR N PACKAGE
(TOP VIEW)

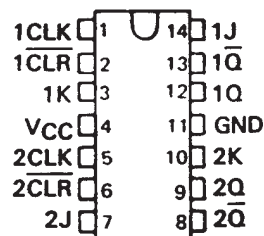

'73
FUNCTION TABLE

INPUTS				OUTPUTS	
CLR	CLK	J	K	Q	\bar{Q}
L	X	X	X	L	H
H	\downarrow	L	L	Q_0	\bar{Q}_0
H	\downarrow	H	L	H	L
H	\downarrow	L	H	L	H
H	\downarrow	H	H	TOGGLE	TOGGLE

'LS73A
FUNCTION TABLE

INPUTS				OUTPUTS	
CLR	CLK	J	K	Q	\bar{Q}
L	X	X	X	L	H
H	\downarrow	L	L	Q_0	\bar{Q}_0
H	\downarrow	H	L	H	L
H	\downarrow	L	H	L	H
H	\downarrow	H	H	TOGGLE	TOGGLE
H	H	X	X	Q_0	\bar{Q}_0

FOR CHIP CARRIER INFORMATION,
CONTACT THE FACTORY

SN5473, SN54LS73A, SN7473, SN74LS73A DUAL J-K FLIP-FLOPS WITH CLEAR

SDLS118 – DECEMBER 1983 – REVISED MARCH 1988

logic symbols†



†These symbols are in accordance with ANSI/IEEE Std. 91-1984 and IEC Publication 617-12.

schematics of inputs and outputs

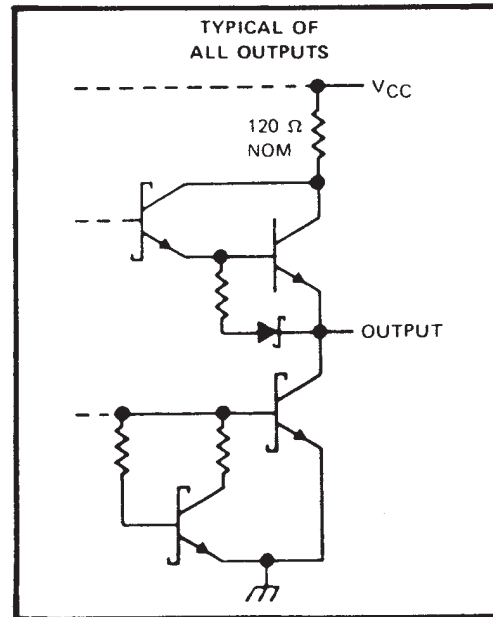
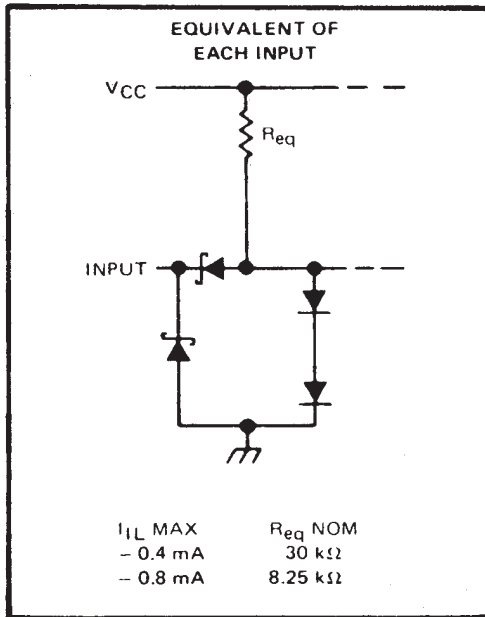
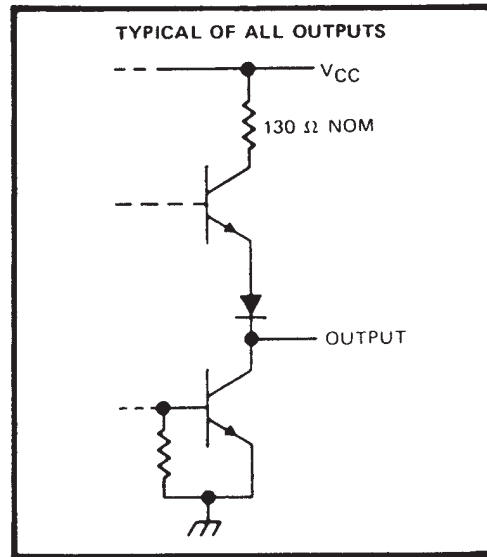
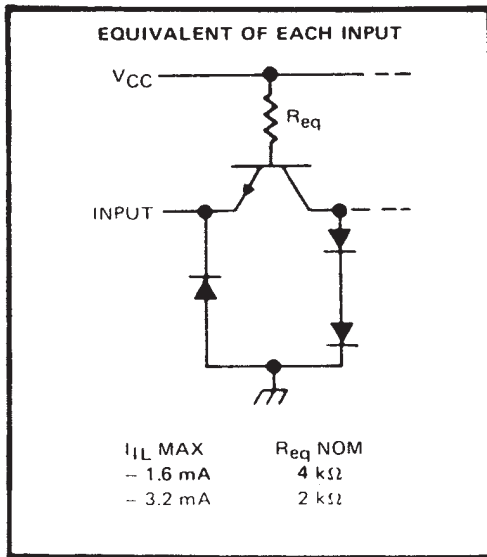

SN5473, SN54LS73A, SN7473, SN74LS73A DUAL J-K FLIP-FLOPS WITH CLEAR

SDLS118 – DECEMBER 1983 – REVISED MARCH 1988

logic diagrams (positive logic)

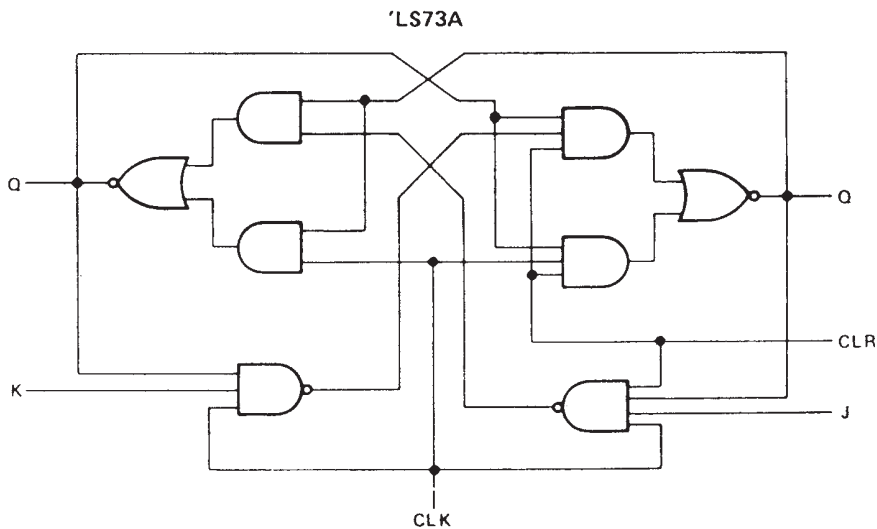
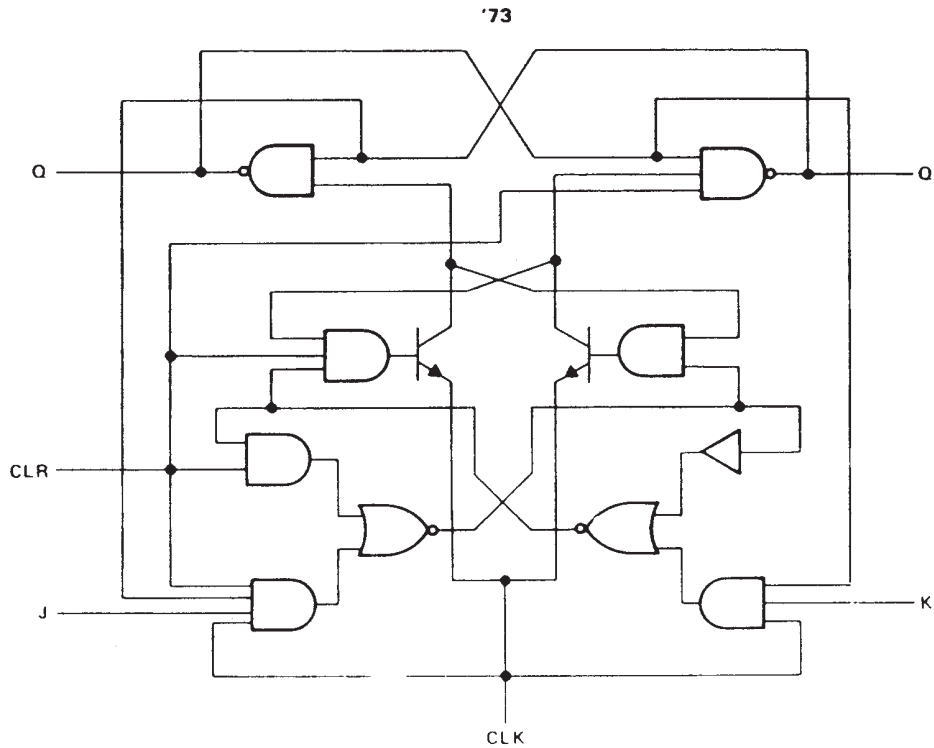

absolute maximum ratings over operating free-air temperature range (unless otherwise noted)

Supply voltage, V_{CC} (See Note 1)	7 V
Input voltage: '73	5.5 V
'LS73A	7 V
Operating free-air temperature range: SN54'	-55°C to 125°C
SN74'	0°C to 70°C
Storage temperature range	-65°C to 150°C

NOTE 1: Voltage values are with respect to network ground terminal.



POST OFFICE BOX 655303 • DALLAS, TEXAS 75265

SN5473, SN54LS73A, SN7473, SN74LS73A DUAL J-K FLIP-FLOPS WITH CLEAR

SDLS118 – DECEMBER 1983 – REVISED MARCH 1988

recommended operating conditions

		SN5473			SN7473			UNIT	
		MIN	NOM	MAX	MIN	NOM	MAX		
V_{CC}	Supply voltage	4.5	5	5.5	4.75	5	5.25	V	
V_{IH}	High-level input voltage	2			2			V	
V_{IL}	Low-level input voltage			0.8			0.8	V	
I_{OH}	High-level output current			-0.4			-0.4	mA	
I_{OL}	Low-level output current			16			16	mA	
t_w	Pulse duration	CLK high		20			20	ns	
		CLK low		47			47		
		\overline{CLR} low		25			25		
t_{su}	Input setup time before CLK \uparrow			0			0	ns	
t_h	Input hold time data after CLK \downarrow			0			0	ns	
T_A	Operating free-air temperature			-55		125	0	70	$^{\circ}C$

electrical characteristics over recommended operating free-air temperature range (unless otherwise noted)

PARAMETER	TEST CONDITIONS [†]	SN5473			SN7473			UNIT
		MIN	TYP [‡]	MAX	MIN	TYP [‡]	MAX	
V_{IK}	$V_{CC} = \text{MIN}$, $I_I = -12 \text{ mA}$			-1.5			-1.5	V
V_{OH}	$V_{CC} = \text{MIN}$, $V_{IH} = 2 \text{ V}$, $V_{IL} = 0.8 \text{ V}$, $I_{OH} = -0.4 \text{ mA}$	2.4	3.4		2.4	3.4		V
V_{OL}	$V_{CC} = \text{MIN}$, $V_{IH} = 2 \text{ V}$, $V_{IL} = 0.8 \text{ V}$, $I_{OL} = 16 \text{ mA}$		0.2	0.4		0.2	0.4	V
I_I	$V_{CC} = \text{MAX}$, $V_I = 5.5 \text{ V}$			1			1	mA
I_{IH}	J or K			40			40	μA
	\overline{CLR} or CLK			80			80	
I_{IL}	J or K			-1.6			-1.6	mA
	\overline{CLR}			-3.2			-3.2	
	CLK			-3.2			-3.2	
I_{OS} [§]	$V_{CC} = \text{MAX}$	-20		-57	-18		-57	mA
I_{CC} [¶]	$V_{CC} = \text{MAX}$, See Note 2		10	20		10	20	mA

[†] For conditions shown as MIN or MAX, use the appropriate value specified under recommended operating conditions.

[‡] All typical values are at $V_{CC} = 5 \text{ V}$, $T_A = 25^{\circ}C$.

[§] Not more than one output should be shorted at a time.

[¶] Average per flip-flop.

NOTE 2: With all outputs open, I_{CC} is measured with the Q and \overline{Q} outputs high in turn. At the time of measurement, the clock input is grounded.

switching characteristics, $V_{CC} = 5 \text{ V}$, $T_A = 25^{\circ}C$ (see note 3)

PARAMETER [#]	FROM (INPUT)	TO (OUTPUT)	TEST CONDITIONS	MIN	TYP	MAX	UNIT
f_{max}				15	20		MHz
t_{PLH}	\overline{CLR}	\overline{Q}	$R_L = 400 \Omega$, $C_L = 15 \text{ pF}$		16	25	ns
t_{PHL}		Q			25	40	ns
t_{PLH}	CLK	Q or \overline{Q}			16	25	ns
t_{PHL}					25	40	ns

[#] f_{max} = maximum clock frequency; t_{PLH} = propagation delay time, low-to-high-level output; t_{PHL} = propagation delay time, high-to-low-level output.

NOTE 3: Load circuits and voltage waveforms are shown in Section 1.



SN5473, SN54LS73A, SN7473, SN74LS73A DUAL J-K FLIP-FLOPS WITH CLEAR

SDLS118 – DECEMBER 1983 – REVISED MARCH 1988

recommended operating conditions

		SN54LS73A			SN74LS73A			UNIT
		MIN	NOM	MAX	MIN	NOM	MAX	
V_{CC}	Supply voltage	4.5	5	5.5	4.75	5	5.25	V
V_{IH}	High-level input voltage	2			2			V
V_{IL}	Low-level input voltage			0.7			0.8	V
I_{OH}	High-level output current			-0.4			-0.4	mA
I_{OL}	Low-level output current			4			8	mA
f_{clock}	Clock frequency	0		30	0		30	MHz
t_w	Pulse duration	CLK high		20	20		ns	
		CLR low		25	20			
t_{su}	Set up time-before CLK ↓	data high or low		20	20		ns	
		CLR inactive		20	20			
t_h	Hold time-data after CLK ↓	0			0			ns
T_A	Operating free-air temperature	-55		125	0		70	°C

electrical characteristics over recommended operating free-air temperature range (unless otherwise noted)

PARAMETER	TEST CONDITIONS†	SN54LS73A			SN74LS73A			UNIT
		MIN	TYP‡	MAX	MIN	TYP‡	MAX	
V_{IK}	$V_{CC} = \text{MIN}$, $I_I = -18 \text{ mA}$			-1.5			-1.5	V
V_{OH}	$V_{CC} = \text{MIN}$, $I_{OH} = -0.4 \text{ mA}$ $V_{IH} = 2 \text{ V}$, $V_{IL} = \text{MAX}$,	2.5	3.4		2.7	3.4		V
V_{OL}	$V_{CC} = \text{MIN}$, $I_{OL} = 4 \text{ mA}$ $V_{IL} = \text{MAX}$, $V_{IH} = 2 \text{ V}$,		0.25	0.4		0.25	0.4	V
	$V_{CC} = \text{MIN}$, $I_{OL} = 8 \text{ mA}$ $V_{IL} = \text{MAX}$, $V_{IH} = 2 \text{ V}$,					0.35	0.5	
I_I	J or K			0.1			0.1	mA
	CLR	$V_{CC} = \text{MAX}$, $V_I = 7 \text{ V}$		0.3			0.3	
	CLK			0.4			0.4	
I_{IH}	J or K			20			20	μA
	CLR	$V_{CC} = \text{MAX}$, $V_I = 2.7 \text{ V}$		60			60	
	CLK			80			80	
I_{IL}	J or K	$V_{CC} = \text{MAX}$, $V_I = 0.4 \text{ V}$		-0.4			-0.4	mA
	CLR or CLK			-0.8			-0.8	
$I_{OS}§$	$V_{CC} = \text{MAX}$, See Note 4	-20		-100	-20		-100	mA
$I_{CC} \text{ (Total)}$	$V_{CC} = \text{MAX}$, See Note 2		4	6		4	6	mA

† For conditions shown as MIN or MAX, use the appropriate value specified under recommended operating conditions.

‡ All typical values are at $V_{CC} = 5 \text{ V}$, $T_A = 25^\circ\text{C}$.

§ Not more than one output should be shorted at a time, and the duration of the short circuit should not exceed one second.

NOTE 2: With all outputs open, I_{CC} is measured with the Q and \bar{Q} outputs high in turn. At the time of measurement, the clock input is grounded.

NOTE 4: For certain devices where state commutation can be caused by shorting an output to ground, an equivalent test may be performed with $V_O = 2.25 \text{ V}$ and 2.125 V for the 54 family and the 74 family, respectively, with the minimum and maximum limits reduced to one half of their stated values.

switching characteristics, $V_{CC} = 5 \text{ V}$, $T_A = 25^\circ\text{C}$ (see note 3)

PARAMETER	FROM (INPUT)	TO (OUTPUT)	TEST CONDITIONS	MIN	TYP	MAX	UNIT
f_{max}				30	45		MHz
t_{PLH}	CLR or CLK	Q or \bar{Q}	$R_L = 2 \text{ k}\Omega$, $C_L = 15 \text{ pF}$		15	20	ns
t_{PHL}					15	20	ns

NOTE 3: Load circuits and voltage waveforms are shown in Section 1.



PACKAGING INFORMATION

Orderable Device	Status (1)	Package Type	Package Drawing	Pins	Package Qty	Eco Plan (2)	Lead finish/ Ball material (6)	MSL Peak Temp (3)	Op Temp (°C)	Device Marking (4/5)	Samples
5962-9675101QCA	ACTIVE	CDIP	J	14	25	Non-RoHS & Green	SNPB	N / A for Pkg Type	-55 to 125	5962-9675101QC A SNJ54LS73AJ	Samples
5962-9675101QDA	ACTIVE	CFP	W	14	25	Non-RoHS & Green	SNPB	N / A for Pkg Type	-55 to 125	5962-9675101QD A SNJ54LS73AW	Samples
5962-9675101QDA	ACTIVE	CFP	W	14	25	Non-RoHS & Green	SNPB	N / A for Pkg Type	-55 to 125	5962-9675101QD A SNJ54LS73AW	Samples
SN54LS73AJ	ACTIVE	CDIP	J	14	25	Non-RoHS & Green	SNPB	N / A for Pkg Type	-55 to 125	SN54LS73AJ	Samples
SN54LS73AJ	ACTIVE	CDIP	J	14	25	Non-RoHS & Green	SNPB	N / A for Pkg Type	-55 to 125	SN54LS73AJ	Samples
SN74LS73ADR	ACTIVE	SOIC	D	14	2500	RoHS & Green	NIPDAU	Level-1-260C-UNLIM	0 to 70	LS73A	Samples
SN74LS73ADR	ACTIVE	SOIC	D	14	2500	RoHS & Green	NIPDAU	Level-1-260C-UNLIM	0 to 70	LS73A	Samples
SN74LS73AN	ACTIVE	PDIP	N	14	25	RoHS & Green	NIPDAU	N / A for Pkg Type	0 to 70	SN74LS73AN	Samples
SN74LS73AN	ACTIVE	PDIP	N	14	25	RoHS & Green	NIPDAU	N / A for Pkg Type	0 to 70	SN74LS73AN	Samples
SN74LS73ANE4	ACTIVE	PDIP	N	14	25	RoHS & Green	NIPDAU	N / A for Pkg Type	0 to 70	SN74LS73AN	Samples
SN74LS73ANE4	ACTIVE	PDIP	N	14	25	RoHS & Green	NIPDAU	N / A for Pkg Type	0 to 70	SN74LS73AN	Samples
SNJ54LS73AJ	ACTIVE	CDIP	J	14	25	Non-RoHS & Green	SNPB	N / A for Pkg Type	-55 to 125	5962-9675101QC A SNJ54LS73AJ	Samples
SNJ54LS73AJ	ACTIVE	CDIP	J	14	25	Non-RoHS & Green	SNPB	N / A for Pkg Type	-55 to 125	5962-9675101QC A SNJ54LS73AJ	Samples
SNJ54LS73AW	ACTIVE	CFP	W	14	25	Non-RoHS & Green	SNPB	N / A for Pkg Type	-55 to 125	5962-9675101QD A SNJ54LS73AW	Samples
SNJ54LS73AW	ACTIVE	CFP	W	14	25	Non-RoHS & Green	SNPB	N / A for Pkg Type	-55 to 125	5962-9675101QD A	Samples

Orderable Device	Status (1)	Package Type	Package Drawing	Pins	Package Qty	Eco Plan (2)	Lead finish/ Ball material (6)	MSL Peak Temp (3)	Op Temp (°C)	Device Marking (4/5)	Samples
										SNJ54LS73AW	

(1) The marketing status values are defined as follows:

ACTIVE: Product device recommended for new designs.

LIFEBUY: TI has announced that the device will be discontinued, and a lifetime-buy period is in effect.

NRND: Not recommended for new designs. Device is in production to support existing customers, but TI does not recommend using this part in a new design.

PREVIEW: Device has been announced but is not in production. Samples may or may not be available.

OBSOLETE: TI has discontinued the production of the device.

(2) **RoHS:** TI defines "RoHS" to mean semiconductor products that are compliant with the current EU RoHS requirements for all 10 RoHS substances, including the requirement that RoHS substance do not exceed 0.1% by weight in homogeneous materials. Where designed to be soldered at high temperatures, "RoHS" products are suitable for use in specified lead-free processes. TI may reference these types of products as "Pb-Free".

RoHS Exempt: TI defines "RoHS Exempt" to mean products that contain lead but are compliant with EU RoHS pursuant to a specific EU RoHS exemption.

Green: TI defines "Green" to mean the content of Chlorine (Cl) and Bromine (Br) based flame retardants meet JS709B low halogen requirements of <=1000ppm threshold. Antimony trioxide based flame retardants must also meet the <=1000ppm threshold requirement.

(3) MSL, Peak Temp. - The Moisture Sensitivity Level rating according to the JEDEC industry standard classifications, and peak solder temperature.

(4) There may be additional marking, which relates to the logo, the lot trace code information, or the environmental category on the device.

(5) Multiple Device Markings will be inside parentheses. Only one Device Marking contained in parentheses and separated by a "~" will appear on a device. If a line is indented then it is a continuation of the previous line and the two combined represent the entire Device Marking for that device.

(6) Lead finish/Ball material - Orderable Devices may have multiple material finish options. Finish options are separated by a vertical ruled line. Lead finish/Ball material values may wrap to two lines if the finish value exceeds the maximum column width.

Important Information and Disclaimer:The information provided on this page represents TI's knowledge and belief as of the date that it is provided. TI bases its knowledge and belief on information provided by third parties, and makes no representation or warranty as to the accuracy of such information. Efforts are underway to better integrate information from third parties. TI has taken and continues to take reasonable steps to provide representative and accurate information but may not have conducted destructive testing or chemical analysis on incoming materials and chemicals. TI and TI suppliers consider certain information to be proprietary, and thus CAS numbers and other limited information may not be available for release.

In no event shall TI's liability arising out of such information exceed the total purchase price of the TI part(s) at issue in this document sold by TI to Customer on an annual basis.

OTHER QUALIFIED VERSIONS OF SN54LS73A, SN74LS73A :

- Catalog : [SN74LS73A](#)

- Military : [SN54LS73A](#)

NOTE: Qualified Version Definitions:

- Catalog - TI's standard catalog product
- Military - QML certified for Military and Defense Applications

TAPE AND REEL INFORMATION

QUADRANT ASSIGNMENTS FOR PIN 1 ORIENTATION IN TAPE

*All dimensions are nominal

Device	Package Type	Package Drawing	Pins	SPQ	Reel Diameter (mm)	Reel Width W1 (mm)	A0 (mm)	B0 (mm)	K0 (mm)	P1 (mm)	W (mm)	Pin1 Quadrant
SN74LS73ADR	SOIC	D	14	2500	330.0	16.4	6.5	9.0	2.1	8.0	16.0	Q1

TAPE AND REEL BOX DIMENSIONS

*All dimensions are nominal

Device	Package Type	Package Drawing	Pins	SPQ	Length (mm)	Width (mm)	Height (mm)
SN74LS73ADR	SOIC	D	14	2500	356.0	356.0	35.0

TUBE

*All dimensions are nominal

Device	Package Name	Package Type	Pins	SPQ	L (mm)	W (mm)	T (μm)	B (mm)
5962-9675101QDA	W	CFP	14	25	506.98	26.16	6220	NA
SN74LS73AN	N	PDIP	14	25	506	13.97	11230	4.32
SN74LS73AN	N	PDIP	14	25	506	13.97	11230	4.32
SN74LS73ANE4	N	PDIP	14	25	506	13.97	11230	4.32
SN74LS73ANE4	N	PDIP	14	25	506	13.97	11230	4.32
SNJ54LS73AW	W	CFP	14	25	506.98	26.16	6220	NA

W (R-GDFP-F14)

CERAMIC DUAL FLATPACK



- NOTES:
- A. All linear dimensions are in inches (millimeters).
 - B. This drawing is subject to change without notice.
 - C. This package can be hermetically sealed with a ceramic lid using glass frit.
 - D. Index point is provided on cap for terminal identification only.
 - E. Falls within MIL STD 1835 GDFP1-F14

J 14

GENERIC PACKAGE VIEW
CDIP - 5.08 mm max height
CERAMIC DUAL IN LINE PACKAGE



Images above are just a representation of the package family, actual package may vary.
Refer to the product data sheet for package details.

4040083-5/G

J0014A



PACKAGE OUTLINE

CDIP - 5.08 mm max height

CERAMIC DUAL IN LINE PACKAGE



4214771/A 05/2017

NOTES:

1. All controlling linear dimensions are in inches. Dimensions in brackets are in millimeters. Any dimension in brackets or parenthesis are for reference only. Dimensioning and tolerancing per ASME Y14.5M.
2. This drawing is subject to change without notice.
3. This package is hermetically sealed with a ceramic lid using glass frit.
4. Index point is provided on cap for terminal identification only and on press ceramic glass frit seal only.
5. Falls within MIL-STD-1835 and GDIP1-T14.

EXAMPLE BOARD LAYOUT

J0014A

CDIP - 5.08 mm max height

CERAMIC DUAL IN LINE PACKAGE



LAND PATTERN EXAMPLE
NON-SOLDER MASK DEFINED
SCALE: 5X



4214771/A 05/2017

D (R-PDSO-G14)

PLASTIC SMALL OUTLINE



- NOTES:
- A. All linear dimensions are in inches (millimeters).
 - B. This drawing is subject to change without notice.
 -  Body length does not include mold flash, protrusions, or gate burrs. Mold flash, protrusions, or gate burrs shall not exceed 0.006 (0,15) each side.
 -  Body width does not include interlead flash. Interlead flash shall not exceed 0.017 (0,43) each side.
 - E. Reference JEDEC MS-012 variation AB.

D (R-PDSO-G14)

PLASTIC SMALL OUTLINE



4211283-3/E 08/12

- NOTES:
- A. All linear dimensions are in millimeters.
 - B. This drawing is subject to change without notice.
 - C. Publication IPC-7351 is recommended for alternate designs.
 - D. Laser cutting apertures with trapezoidal walls and also rounding corners will offer better paste release. Customers should contact their board assembly site for stencil design recommendations. Refer to IPC-7525 for other stencil recommendations.
 - E. Customers should contact their board fabrication site for solder mask tolerances between and around signal pads.

N (R-PDIP-T**)

PLASTIC DUAL-IN-LINE PACKAGE

16 PINS SHOWN



4040049/E 12/2002

- NOTES:
- A. All linear dimensions are in inches (millimeters).
 - B. This drawing is subject to change without notice.
 - $\triangle C$ Falls within JEDEC MS-001, except 18 and 20 pin minimum body length (Dim A).
 - $\triangle D$ The 20 pin end lead shoulder width is a vendor option, either half or full width.

IMPORTANT NOTICE AND DISCLAIMER

TI PROVIDES TECHNICAL AND RELIABILITY DATA (INCLUDING DATA SHEETS), DESIGN RESOURCES (INCLUDING REFERENCE DESIGNS), APPLICATION OR OTHER DESIGN ADVICE, WEB TOOLS, SAFETY INFORMATION, AND OTHER RESOURCES "AS IS" AND WITH ALL FAULTS, AND DISCLAIMS ALL WARRANTIES, EXPRESS AND IMPLIED, INCLUDING WITHOUT LIMITATION ANY IMPLIED WARRANTIES OF MERCHANTABILITY, FITNESS FOR A PARTICULAR PURPOSE OR NON-INFRINGEMENT OF THIRD PARTY INTELLECTUAL PROPERTY RIGHTS.

These resources are intended for skilled developers designing with TI products. You are solely responsible for (1) selecting the appropriate TI products for your application, (2) designing, validating and testing your application, and (3) ensuring your application meets applicable standards, and any other safety, security, regulatory or other requirements.

These resources are subject to change without notice. TI grants you permission to use these resources only for development of an application that uses the TI products described in the resource. Other reproduction and display of these resources is prohibited. No license is granted to any other TI intellectual property right or to any third party intellectual property right. TI disclaims responsibility for, and you will fully indemnify TI and its representatives against, any claims, damages, costs, losses, and liabilities arising out of your use of these resources.

TI's products are provided subject to [TI's Terms of Sale](#) or other applicable terms available either on [ti.com](https://www.ti.com) or provided in conjunction with such TI products. TI's provision of these resources does not expand or otherwise alter TI's applicable warranties or warranty disclaimers for TI products.

TI objects to and rejects any additional or different terms you may have proposed.

Mailing Address: Texas Instruments, Post Office Box 655303, Dallas, Texas 75265
Copyright © 2024, Texas Instruments Incorporated

Looking for pricing, stock, or lifecycle information?

Click below to explore more details on WIN SOURCE:

 [View SN54LS73AJ on WIN SOURCE](#)

 [Texas Instruments](#) Information

Optimize Your Supply Chain with WIN SOURCE Solutions

-  Global Sourcing Solution
-  Obsolete Management
-  Cost Control Management
-  Shortage Management
-  Alternative Solution
-  Excess Inventory Management