



**THE DATASHEET OF  
PTB48500AAS**



## DUAL-OUTPUT, 48-V INPUT ISOLATED DC/DC CONVERTER for xDSL

### FEATURES

- Dual Outputs (Independently Regulated)
- Input Voltage Range: 36 V to 75 V
- Power-Up/Down Sequencing
- 1500 VDC Isolation
- Over-Current Protection
- Over-Temperature Shutdown
- Under-Voltage Lockout
- Fixed Frequency Operation
- Temp Range: –40°C to 85°C
- Industry Standard Outline
- Operates with PTB4851x for Complete AC7 Power Solution
- Powers up to 64 DSL Ports
- Safety Approvals:
  - UL/cUL 60950
  - EN 60950



### DESCRIPTION

The PTB4850x power modules are a dual-output isolated DC/DC converter, designed to provide the logic supply voltages for AC-7 based xDSL applications. The PTB48500 is rated for 13 A of total output current, making it suitable for 32-channel xDSL applications. The PTB48501 and PTB48502 provide output current for powering up to 64 xDSL channels. The PTB48501 is rated for 16.5 A total output current, and the PTB48502, 21 A. The PTB48502 incorporates 10 W of additional capacity for powering peripheral circuitry. Any of these converters can be used for other applications with similar power requirements.

The modules operate from a standard telecom (–48 V) central office (CO) supply and include an *on/off* enable control, output current limit, over-temperature protection, input under-voltage lockout (UVLO). The PTB48500 and PTB48501 also incorporate a power-up reset (POR) output.

The modules are designed to operate with one of the PTB4851x DC/DC converter modules. The combination of PTB4850x and PTB4851x converter provides the complete the power supply for an AC7 chipset. The *EN Out* and *Sync Out* pins provide compatible output signals for controlling both the power up sequence and switching frequency the PTB48510.

The PTB4850x modules employ double-sided surface mount construction, and are an industry standard size.



Please be aware that an important notice concerning availability, standard warranty, and use in critical applications of Texas Instruments semiconductor products and disclaimers thereto appears at the end of this data sheet.

### STAND-ALONE APPLICATION

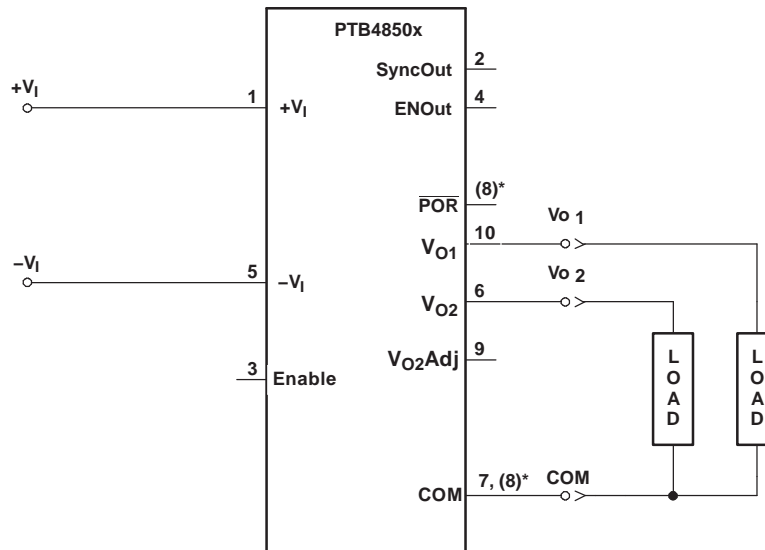

\* Pin 8 is COM on PTB48502

### ORDERING INFORMATION

Base Part No. (PTB4850_xxx)			Output Voltage (PTB4850x_xx)		Package Options (PT4850xx_ _)		
Order Prefix	Description		Code	Voltage	Code	Description	Pkg Ref.( <sup>1</sup> )
PTB48500xxx	13 A	(32-Ports)	A	3.3 V / 1.2 V	AH	Horiz. T/H	(ERH)
PTB48501xxx	16.5 A	(48/64-Ports)			AS	SMD, Standard( <sup>2</sup> )	(ERJ)
PTB48502xx	21 A	(64-Ports + 10 W)			AZ	SMD, Pb-free	(ERJ)

- (1) Reference the applicable package reference drawing for the dimensions and PC board layout.  
 (2) *Standard* option specifies 63/37, Sn/Pb pin solder material.

### Environmental and General Specifications

(Unless otherwise stated, all voltages are with respect to  $-V_I$ )

			VALUE	UNIT
$V_I$	Input Voltage Range	Over output load range	36 to 75	VDC
	Isolation Voltage	Input-output/input/case	1500	V
	Capacitance	Input to output	1500	pF
	Resistance	Input to output	10	mΩ
$T_A$	Operating Temperature Range	Over $V_{in}$ Range	-40 to 85	°C
OTP	Over-Temperature Protection	Shutdown threshold	115	°C
		Hysteresis	10	
$T_{reflow}$	Solder Reflow Temperature	Surface temperature of module body or pins	235 <sup>(1)</sup>	°C
$T_s$	Storage Temperature		-40 to 125	°C
	Mechanical Shock	Per Mil-STD-883D, Method 2002.3 1 msec, 1/2 Sine, mounted	500	G
	Mechanical Vibration Mil-STD-883D	Method 2007.2	Suffix H	20
		20-2000 Hz	Suffix C	5
	Weight			grams
	Flammability	Meets UL 94V-O		

- (1) During reflow of SMD package version do not elevate peak temperature of the module, pins or internal components above the stated maximum.

**ELECTRICAL CHARACTERISTICS (PTB48500A)**(Unless otherwise stated,  $T_A = 25^\circ\text{C}$ ,  $V_I = 48\text{ V}$ ,  $C_I = 0\ \mu\text{F}$ ,  $C_O = 0\ \mu\text{F}$ , and  $I_O = 50\% I_{O,max}$ )

PARAMETER		TEST CONDITIONS		PTB48500A			UNIT		
				MIN	TYP	MAX			
$P_{O1}, P_{O2}$	Output Power			$V_{O1}$ (3.3 V)		19.8	W		
				$V_{O2}$ (1.2 V)		8.4			
$P_{O\text{ total}}$	Both outputs					28	W		
$I_{O1}, I_{O2}$	Output Current	Over $V_I$ range		$V_{O1}$ (3.3 V)	0	6 <sup>(1)</sup>	A		
				$V_{O2}$ (1.2 V)	0	7 <sup>(1)</sup>			
$I_{O1} + I_{O2}$		Total (both outputs)			0	13	A		
$V_{O1}$	Output Voltage					3.2	3.3	3.4	V
$V_{O2}$						1.16	1.2	1.24	
$\Delta\text{Reg}_{\text{temp}}$	Temperature Variation	$-40^\circ\text{C} \leq T_A \leq 85^\circ\text{C}$ , $I_O = I_{O\text{ min}}$		$V_{O1}$		$\pm 0.5$	% $V_O$		
				$V_{O2}$		$\pm 0.8$			
$\Delta\text{Reg}_{\text{line}}$	Line Regulation	Over $V_I$ range		$V_{O1}, V_{O2}$		$\pm 1$	$\pm 10$	mV	
$\Delta\text{Reg}_{\text{load}}$	Load Regulation	Over $I_O$ range		$V_{O1}, V_{O2}$		$\pm 3$	$\pm 12$	mV	
$\Delta\text{Reg}_{\text{cross}}$	Cross Regulation	$I_{O\text{ min}} \leq I_{O2} \leq I_{O\text{ max}}$ , $I_{O1} = 1\text{ A}$		$\Delta V_{O1}$			10	mV	
		$I_{O\text{ min}} \leq I_{O1} \leq I_{O\text{ max}}$ , $I_{O2} = 1\text{ A}$		$\Delta V_{O2}$			10		
$\eta$	Efficiency	$I_{O1}, I_{O2} = I_{O\text{ max}}$				82%			
$V_r$	$V_O$ Ripple (pk-pk)	20 MHz bandwidth		$V_{O1}$		20	50	mV <sub>pp</sub>	
				$V_{O2}$		20	50		
$t_{\text{tr}}$	Transient Response	1 A/ $\mu\text{s}$ load step, 50% to 100% $I_{O\text{ max}}$				30	$\mu\text{s}$		
$\Delta V_{\text{tr}}$		$V_{O1}, V_{O2}$ over/undershoot				$\pm 2.0$	% $V_O$		
$I_{O\text{ trip}}$	Over Current Threshold	$V_I = 36\text{ V}$ , reset followed by auto-recovery	$I_{O1} + I_{O2}$			13.5	16	A	
$V_{\text{adj}}$	Output Voltage Adjust Range	$V_{O2}$ only				-10	20	% $V_O$	
$f_s$	Switching Frequency	Over $V_I$ and $I_O$ ranges				500	550	600	kHz
$V_{I\text{ on}}$	Under-Voltage Lockout	$V_I$ increasing					34	V	
$V_{I\text{ off}}$		$V_I$ decreasing					32		
$V_{IH}$	On/Off Enable (pin 3) Input High Voltage	Referenced to $-V_I$ (pin 5)				3.6	75 <sup>(2)</sup>	V	
$V_{IL}$	Input Low Voltage					-0.2	0.8		
$I_{IL}$	Input Low Current						-1		mA
$I_{I\text{ standby}}$	Standby Input Current	Pins 3 and 5 connected					2	mA	
$C_I$	Internal Input Capacitance						2	$\mu\text{F}$	
$C_{O1}$	External Output Capacitance					0 <sup>(3)</sup>	5000	$\mu\text{F}$	
$C_{O2}$						0 <sup>(3)</sup>	5000		
MTBF	Reliability	Per Telcordia SR-332 50% stress, $T_A = 40^\circ\text{C}$ , ground benign				1.5		$10^6$ Hrs	

- (1) See Safe Operating Area curves or contact the factory for the appropriate derating.
- (2) The On/Off Enable (pin 3) has an internal pull-up and may be controlled with an open-collector (or open-drain) transistor. The input is diode protected and may be connected to  $+V_I$ . The maximum open-circuit voltage is 7 V. If it is left open circuit the converter will operate when input power is applied.
- (3) An output capacitor is not required.

## ELECTRICAL CHARACTERISTICS (PTB48501A)

(Unless otherwise stated,  $T_A = 25^\circ\text{C}$ ,  $V_I = 48\text{ V}$ ,  $C_I = 0\ \mu\text{F}$ ,  $C_O = 0\ \mu\text{F}$ , and  $I_O = 50\% I_{O,max}$ )

PARAMETER		TEST CONDITIONS		PTB48501A			UNIT	
				MIN	TYP	MAX		
$P_{O1}, P_{O2}$	Output Power			$V_{O1}$ (3.3 V)		19.8	W	
				$V_{O2}$ (1.2 V)		12.6		
$P_{O\ total}$	Both outputs					32.4	W	
$I_{O1}, I_{O2}$	Output Current	Over $V_I$ range		$V_{O1}$ (3.3 V)	0	6 <sup>(1)</sup>	A	
				$V_{O2}$ (1.2 V)	0	10.5 <sup>(1)</sup>		
$I_{O1} + I_{O2}$		Total (both outputs)		0		16.5	A	
$V_{O1}$	Output Voltage	Includes set point, line, load, $-40^\circ\text{C} \leq T_A \leq 85^\circ\text{C}$			3.2	3.3	3.4	V
$V_{O2}$					1.16	1.2	1.24	
$\Delta\text{Reg}_{temp}$	Temperature Variation	$-40^\circ\text{C} \leq T_A \leq 85^\circ\text{C}$ , $I_O = I_{O\ min}$		$V_{O1}$	$\pm 0.5$		% $V_O$	
				$V_{O2}$	$\pm 0.8$			
$\Delta\text{Reg}_{line}$	Line Regulation	Over $V_I$ range	$V_{O1}, V_{O2}$		$\pm 1$	$\pm 10$	mV	
$\Delta\text{Reg}_{load}$	Load Regulation	Over $I_O$ range	$V_{O1}, V_{O2}$		$\pm 3$	$\pm 12$	mV	
$\Delta\text{Reg}_{cross}$	Cross Regulation	$I_{O\ min} \leq I_{O2} \leq I_{O,max}$ , $I_{O1} = 1\text{ A}$	$\Delta V_{O1}$			10	mV	
		$I_{O\ min} \leq I_{O1} \leq I_{O,max}$ , $I_{O2} = 1\text{ A}$	$\Delta V_{O2}$			10		
$\eta$	Efficiency	$I_{O1}, I_{O2} = I_{O,max}$			81%			
$V_r$	$V_O$ Ripple (pk-pk)	20 MHz bandwidth		$V_{O1}$	20	50	mV <sub>pp</sub>	
				$V_{O2}$	20	50		
$t_{tr}$	Transient Response	1 A/ $\mu\text{s}$ load step, 50% to 100% $I_{O,max}$			30		$\mu\text{s}$	
$\Delta V_{tr}$		$V_{O1}, V_{O2}$ over/undershoot			$\pm 2.0$		% $V_O$	
$I_{Otrip}$	Over Current Threshold	$V_I = 36\text{ V}$ , reset followed by auto-recovery	$I_{O1} + I_{O2}$		24		A	
$V_{adj}$	Output Voltage Adjust Range	$V_{O2}$ only			-20	10	% $V_O$	
$f_s$	Switching Frequency	Over $V_I$ and $I_O$ ranges		500	550	600	kHz	
$V_{I\ on}$	Under-Voltage Lockout	$V_I$ increasing			34		V	
$V_{I\ off}$		$V_I$ decreasing			32			
$V_{IH}$	On/Off Enable (pin 3) Input High Voltage	Referenced to $-V_I$ (pin 5)		3.6		75 <sup>(2)</sup>	V	
$V_{IL}$	Input Low Voltage			-0.2		0.8		
$I_{IL}$	Input Low Current					-1		mA
$I_I\ standby$	Standby Input Current	Pins 3 and 5 connected			2		mA	
$C_I$	Internal Input Capacitance				2		$\mu\text{F}$	
$C_{O1}$	External Output Capacitance			0 <sup>(3)</sup>		5000	$\mu\text{F}$	
$C_{O2}$				0 <sup>(3)</sup>		5000		
MTBF	Reliability	Per Telcordia SR-332 50% stress, $T_A = 40^\circ\text{C}$ , ground benign		1.5			$10^6$ Hrs	

- (1) See Safe Operating Area curves or contact the factory for the appropriate derating.
- (2) The On/Off Enable (pin 3) has an internal pull-up and may be controlled with an open-collector (or open-drain) transistor. The input is diode protected and may be connected to  $+V_I$ . The maximum open-circuit voltage is 7 V. If it is left open circuit the converter will operate when input power is applied.
- (3) An output capacitor is not required.

**ELECTRICAL CHARACTERISTICS (PTB48502A)**(Unless otherwise stated,  $T_A = 25^\circ\text{C}$ ,  $V_I = 48\text{ V}$ ,  $C_I = 0\ \mu\text{F}$ ,  $C_O = 0\ \mu\text{F}$ , and  $I_O = 50\% I_{O,max}$ )

PARAMETER		TEST CONDITIONS		PTB48502A			UNIT			
				MIN	TYP	MAX				
$P_{O1}, P_{O2}$	Output Power			$V_{O1}$ (3.3 V)		33	W			
				$V_{O2}$ (1.2 V)		15.6				
$P_{O\ total}$	Both outputs					45	W			
$I_{O1}, I_{O2}$	Output Current	Over $V_I$ range		$V_{O1}$ (3.3 V)	0	$10^{(1)}$	A			
				$V_{O2}$ (1.2 V)	0	$13^{(1)}$				
$I_{O1} + I_{O2}$		Total (both outputs)			0	21	A			
$V_{O1}$	Output Voltage	Includes set point, line, load, $-40^\circ\text{C} \leq T_A \leq 85^\circ\text{C}$			3.2	3.3	3.4	V		
$V_{O2}$					1.16	1.2	1.24			
$\Delta\text{Reg}_{temp}$	Temperature Variation	$-40^\circ\text{C} \leq T_A \leq 85^\circ\text{C}$ , $I_O = I_{O\ min}$		$V_{O1}$	$\pm 0.5$		% $V_O$			
				$V_{O2}$	$\pm 0.8$					
$\Delta\text{Reg}_{line}$	Line Regulation	Over $V_I$ range	$V_{O1}, V_{O2}$		$\pm 1$	$\pm 10$	mV			
$\Delta\text{Reg}_{load}$	Load Regulation	Over $I_O$ range	$V_{O1}, V_{O2}$		$\pm 3$	$\pm 12$	mV			
$\Delta\text{Reg}_{cross}$	Cross Regulation	$I_{O\ min} \leq I_{O2} \leq I_{O,max}$ , $I_{O1} = 1\text{ A}$	$\Delta V_{O1}$			10	mV			
		$I_{O\ min} \leq I_{O1} \leq I_{O,max}$ , $I_{O2} = 1\text{ A}$	$\Delta V_{O2}$			10				
$\eta$	Efficiency	$I_{O1}, I_{O2} = I_{O,max}$				82%				
$V_r$	$V_O$ Ripple (pk-pk)	20 MHz bandwidth		$V_{O1}$		20	50	mV <sub>pp</sub>		
				$V_{O2}$		20	50			
$t_{tr}$	Transient Response	1 A/ $\mu\text{s}$ load step, 50% to 100% $I_{O,max}$				30	$\mu\text{s}$			
$\Delta V_{tr}$		$V_{O1}, V_{O2}$ over/undershoot				$\pm 2.0$	% $V_O$			
$I_{Otrip}$	Over Current Threshold	$V_I = 36\text{ V}$ , reset followed by auto-recovery	$I_{O1} + I_{O2}$			24	A			
$V_{adj}$	Output Voltage Adjust Range	$V_{O2}$ only				-20	10	% $V_O$		
$f_s$	Switching Frequency	Over $V_I$ and $I_O$ ranges				500	550	600	kHz	
$V_{I\ on}$	Under-Voltage Lockout	$V_I$ increasing					34	V		
$V_{I\ off}$		$V_I$ decreasing					32			
$V_{IH}$	On/Off Enable (pin 3) Input High Voltage	Referenced to $-V_I$ (pin 5)				3.6		V		
$V_{IL}$	Input Low Voltage					-0.2			$75^{(2)}$	0.8
$I_{IL}$	Input Low Current								-1	
$I_I\ standby$	Standby Input Current	Pins 3 and 5 connected					2		mA	
$C_I$	Internal Input Capacitance						2		$\mu\text{F}$	
$C_{O1}$	External Output Capacitance					$0^{(3)}$		5000	$\mu\text{F}$	
$C_{O2}$						$0^{(3)}$		5000		
MTBF	Reliability	Per Telcordia SR-332 50% stress, $T_A = 40^\circ\text{C}$ , ground benign					1.5		$10^6$ Hrs	

- (1) See Safe Operating Area curves or contact the factory for the appropriate derating.
- (2) The On/Off Enable (pin 3) has an internal pull-up and may be controlled with an open-collector (or open-drain) transistor. The input is diode protected and may be connected to  $+V_I$ . The maximum open-circuit voltage is 7 V. If it is left open circuit the converter will operate when input power is applied.
- (3) An output capacitor is not required.

## DEVICE INFORMATION

### TERMINAL FUNCTIONS

TERMINAL		DESCRIPTION
NAME	NO.	
+V <sub>I</sub> <sup>(1)</sup>	1	The positive input supply for the module with respect to –V <sub>I</sub> . When powering the module from a –48 V telecom central office supply, this input is connected to the primary system ground.
–V <sub>I</sub>	5	The negative input supply for the module, and the 0 VDC reference for the <i>Enable</i> , <i>EN Out</i> , and <i>Sync Out</i> signals. When the module is powered from a +48-V supply, this input is connected to the 48-V Return.
V <sub>O1</sub>	10	The higher regulated power output voltage, which is referenced to the COM node.
V <sub>O2</sub>	6	The lower regulated power output voltage, which is referenced to the COM node.
COM	7	The secondary return reference for the module's two regulated output voltages. It is dc isolated from the input supply pins.
V <sub>O2</sub> Adjust	9	Using a single resistor, this pin allows V <sub>O2</sub> to be adjusted higher or lower than the preset value. If not used, this pin should be left open circuit.
Enable <sup>(2)</sup>	3	This is an open-collector (open-drain) positive logic input that enables the module output. This pin is referenced to –V <sub>I</sub> . A logic 0 at this pin disables the module's outputs, and a high impedance enables the outputs. If not used the pin should be left unconnected.
EN Out	4	This open-collector output may be used to enable the output of other DC/DC converters in applications where the power-up sequence of the related voltages must be precisely controlled. The output is used principally to control the startup up of a PTB4851xx module when powering ADSL circuits based on the AC7 chipset. The signal is referenced to –V <sub>I</sub> , and is active low. It is initially <i>off</i> (high impedance), and turns <i>on</i> when the output voltage, V <sub>O1</sub> , has risen to its nominal set-point voltage.
Sync Out	2	The signal generated by this pin is designed to be used exclusively with the PTB48510 in AC7 ADSL applications. When the <i>Sync Out</i> of this converter is connected directly to the <i>Sync In</i> pin of the PTB48510, both modules will operate at the same switch conversion frequency.
POR <sup>(3)</sup> /COM <sup>(4)</sup>	8	(POR: Available to PTB48500 and PTB48501 only.) This pin produces an active-low power-on reset signal that may be used to reset logic circuitry. The output is set low during power up just as the output voltage from V <sub>O1</sub> starts to rise. It remains low for 10 ms after the voltage at V <sub>O1</sub> has reached its nominal set-point voltage. This signal is referenced to the COM node, and has a 3.3-kΩ internal pull-up resistor to V <sub>O1</sub> .

- (1) Shaded functions indicate signals that are referenced to –V<sub>I</sub>.  
(2) Denotes positive logic: Open = Normal operation, –V<sub>I</sub> = Outputs Off  
(3) Denotes negative logic: High = Normal operation, Low = Reset  
(4) This pin is COM on the PTB48502.

**TYPICAL CHARACTERISTICS** (1)(2)(3)

**CHARACTERISTIC DATA (PTB48500A)**

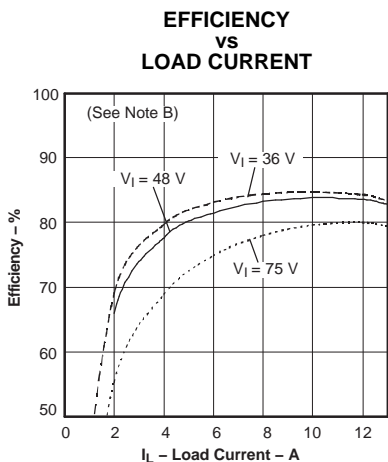

Figure 1.

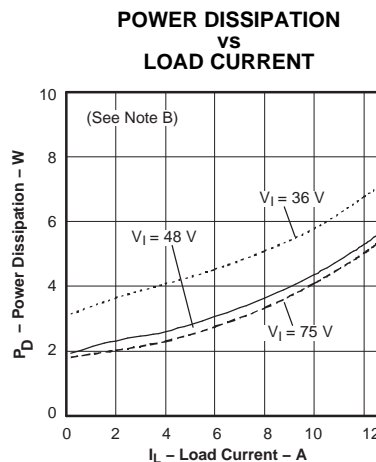

Figure 2.

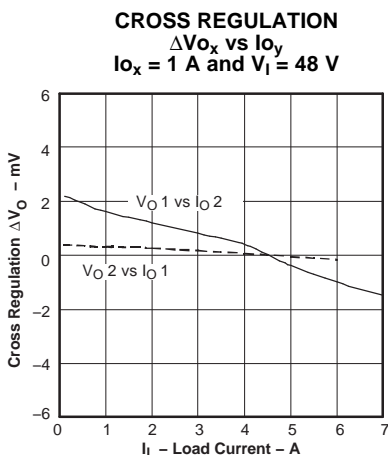

Figure 3.

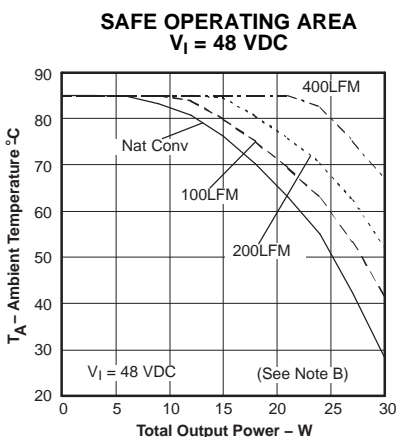

Figure 4.

- (1) A. Characteristic data has been developed from actual products tested at 25°C. This data is considered typical data for the converter.
- (2) B. Load current is increased proportionally from both outputs, up to the indicated maximum value of each respective output.
- (3) C. SOA curves represent the conditions at which internal components are at or below the manufacturer's maximum operating temperatures. Derating limits apply to modules soldered directly to a 4 in. × 4 in. double-sided PCB with 1 oz. copper.

TYPICAL CHARACTERISTICS (1)(2)(3)

PTB48501A CHARACTERISTIC DATA (PTB48501A)

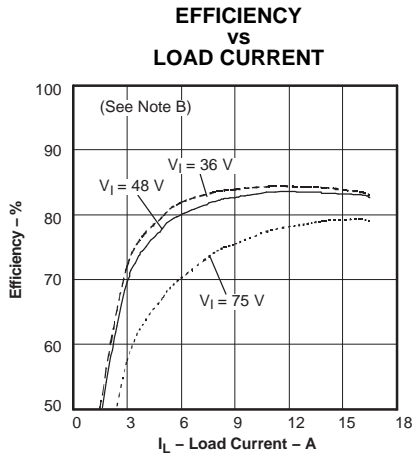

Figure 5.

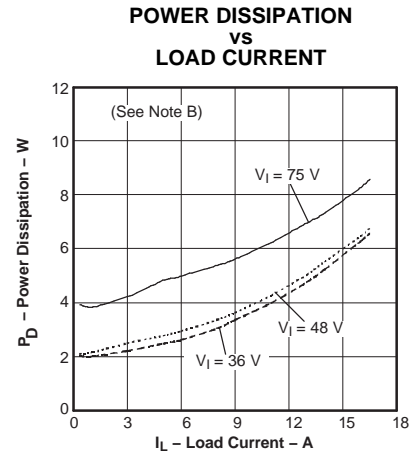

Figure 6.

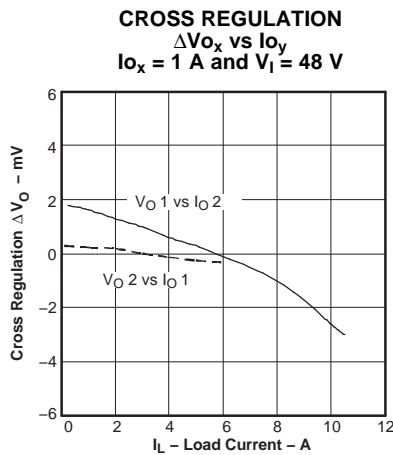

Figure 7.

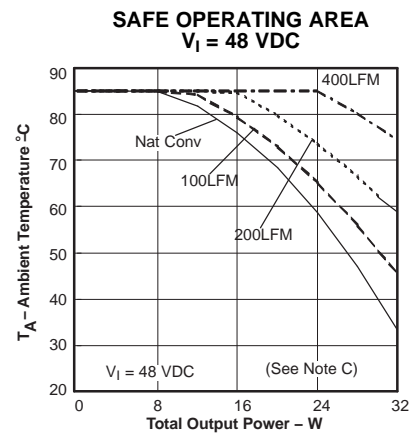

Figure 8.

- (1) A. Characteristic data has been developed from actual products tested at 25°C. This data is considered typical data for the converter.
- (2) B. Load current is increased proportionally from both outputs, up to the indicated maximum value of each respective output.
- (3) C. SOA curves represent the conditions at which internal components are at or below the manufacturer's maximum operating temperatures. Derating limits apply to modules soldered directly to a 4 in. × 4 in. double-sided PCB with 1 oz. copper.

TYPICAL CHARACTERISTICS (1)(2)(3)

CHARACTERISTIC DATA (PTB48502A)  
[ $I_{o1} = 10\text{ A}$ ,  $I_{o2} = 10\text{ A}$  represents 100% load]

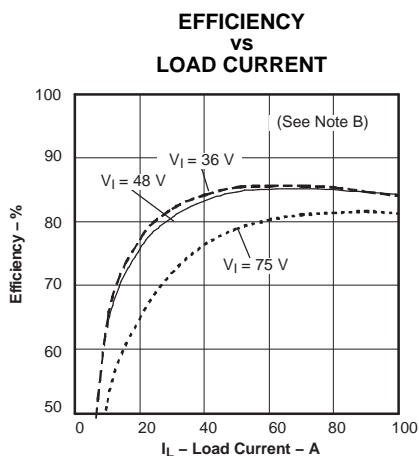

Figure 9.

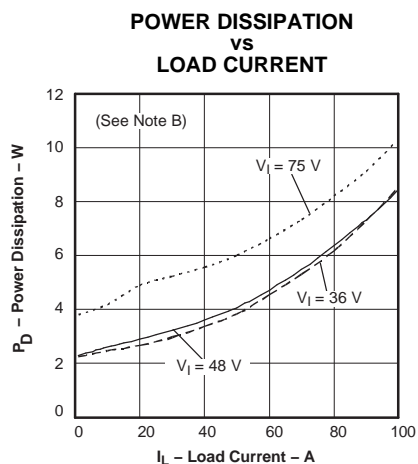

Figure 10.

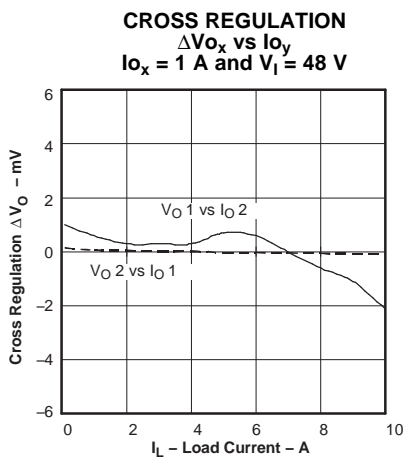

Figure 11.

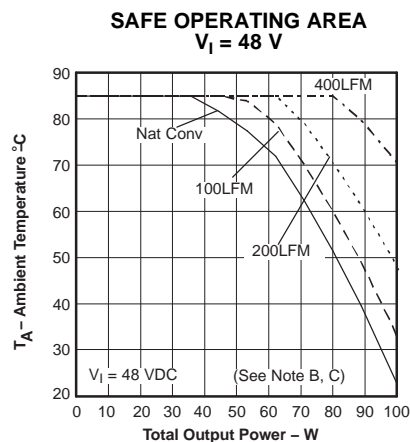

Figure 12.

- (1) A. Characteristic data has been developed from actual products tested at 25°C. This data is considered typical data for the converter.
- (2) B. Load current is increased proportionally from both outputs, up to the indicated maximum value of each respective output.
- (3) C. SOA curves represent the conditions at which internal components are at or below the manufacturer's maximum operating temperatures. Derating limits apply to modules soldered directly to a 4 in. × 4 in. double-sided PCB with 1 oz. copper.

**TYPICAL CHARACTERISTICS** (1)(2)(3)

**CHARACTERISTIC DATA (PTB48502A)**  
[ $I_{O1} = 8\text{ A}$ ,  $I_{O2} = 10\text{ A}$  represents 100% load]

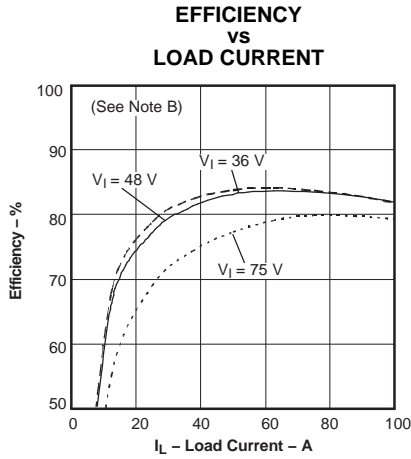

Figure 13.

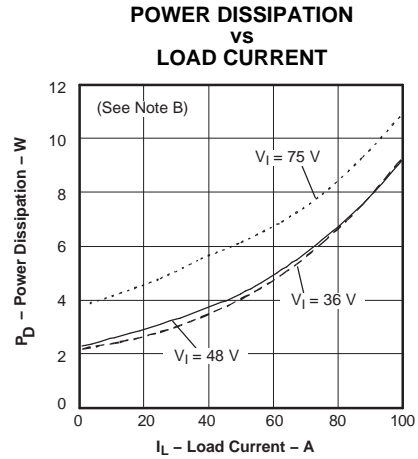

Figure 14.

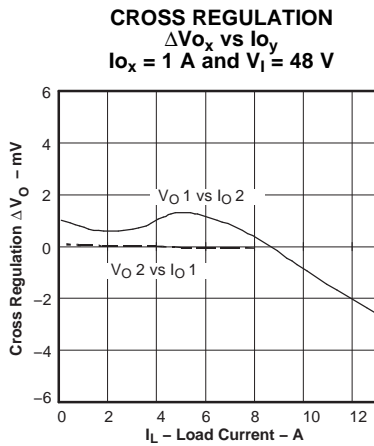

Figure 15.

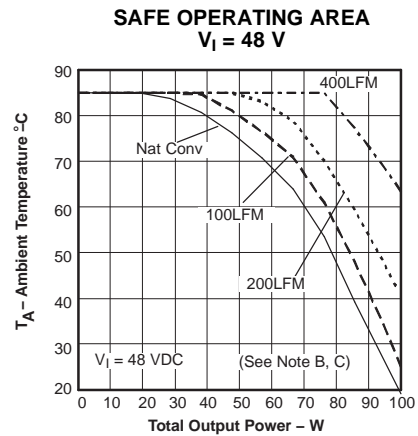

Figure 16.

- (1) A. Characteristic data has been developed from actual products tested at 25°C. This data is considered typical data for the converter.
- (2) B. Load current is increased proportionally from both outputs, up to the indicated maximum value of each respective output.
- (3) C. SOA curves represent the conditions at which internal components are at or below the manufacturer's maximum operating temperatures. Derating limits apply to modules soldered directly to a 4 in. × 4 in. double-sided PCB with 1 oz. copper.

## APPLICATION INFORMATION

## ADJUSTING THE LOWER OUTPUT VOLTAGE OF THE PTB4850x

The PTB4850x series of DC/DC converters are designed to produce two logic-level supply voltages for use with the AC-7 ADSL chipset. The magnitude of lowest output voltage ( $V_{O2}$ ) can be adjusted higher or lower by up to 10% or  $-20\%$  of the nominal. The adjustment method uses a single external resistor.<sup>1</sup> The value of the resistor determines the amount of adjustment, and its placement determines whether the voltage is increased or decreased. The resistor values can be calculated using the appropriate formula (see Equation 1 and Equation 2), or simply selected from the range of values given in Table 2. The placement of each resistor is as follows.

**Adjust Up:** To increase the magnitude of both output voltages, place a resistor  $R_1$  between  $V_{O2}$  Adj (pin 9) and the  $V_{O2}$  (pin 6) voltage rail; see Figure 17.

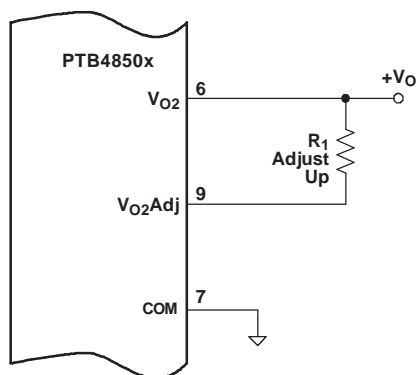

Figure 17. Adjust Up

**Adjust Down:** To decrease the magnitude of both output voltages, add a resistor ( $R_2$ ), between  $V_{O2}$  Adj (pin 9) and the COM (pin 7) voltage rail; see Figure 18.

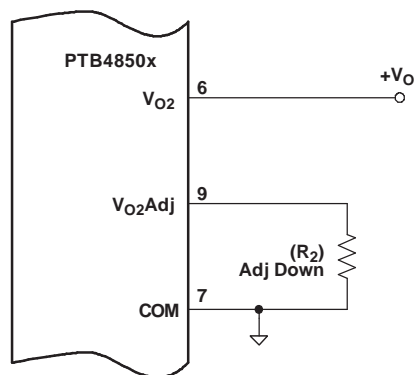

Figure 18. Adjust Down

## CALCULATION OF THE ADJUST RESISTOR

The value of the adjust resistor is calculated using one of the following equations. Use the equation for  $R_1$  to adjust up, or ( $R_2$ ) to adjust down.

$$R_1 [\text{Adjust Up}] = R_p \times \frac{V_a}{(V_a - V_o)} - R_s \text{ k}\Omega \quad (1)$$

$$(R_2) [\text{Adjust Down}] = R_n \times \frac{V_a}{(V_o - V_a)} - R_s \text{ k}\Omega \quad (2)$$

Where:

$V_o$  = Magnitude of the original output voltage

$V_a$  = Magnitude of the adjusted voltage

$R_p$  = Adjust-up constant from Table 1

$R_n$  = Adjust-down constant from Table 1

$R_s$  = Internal series resistor from Table 1

Table 1. Adjustment Range and Formula Parameters

Part No.	PTB48500(1)A	PTB48502A
$V_o(\text{nom})$	1.2 V	1.2 V
$V_a(\text{min})$	0.96 V	0.84 V
$V_a(\text{max})$	1.32 V	1.32 V
$R_p$ (k $\Omega$ )	1.648	1.196
$R_n$ (k $\Omega$ )	4.624	3.598
$R_s$ (k $\Omega$ )	18.2V	13.0

## NOTES:

- A 0.05 W rated resistor may be used. The tolerance should be 1%, with a temperature stability of 100 ppm/ $^{\circ}\text{C}$  or better. Place the resistor in either the  $R_1$  or ( $R_2$ ) location, as close to the converter as possible.
- Never connect capacitors to the  $V_{O2}$  Adj pin. Capacitance added to this pin can affect the stability of the regulated output.

Table 2. Adjust Resistor Values

Part No.		PTB4850xA	PTB48502A
% Adjust	$V_a$ (V)	$R_1 / (R_2)^{(1)}$	$R_1 / (R_2)^{(1)}$
-21	0.848	N/A	(0.5) k $\Omega$
-20	0.960	(0.3) k $\Omega$	(1.4) k $\Omega$
-19	0.972	(1.5) k $\Omega$	(2.3) k $\Omega$
-18	0.984	(2.9) k $\Omega$	(3.4) k $\Omega$
-17	0.996	(4.4) k $\Omega$	(4.6) k $\Omega$
-16	1.008	(6.1) k $\Omega$	(5.9) k $\Omega$
-15	1.020	(8.0) k $\Omega$	(7.4) k $\Omega$
-14	1.032	(10.2) k $\Omega$	(9.1) k $\Omega$

(1)  $R_1$  =Adjust up, ( $R_2$ ) =Adjust down

Table 2. Adjust Resistor Values (continued)

Part No.		PTB4850xA	PTB48502A
% Adjust	V <sub>a</sub> (V)	R <sub>1</sub> / (R <sub>2</sub> ) <sup>(1)</sup>	R <sub>1</sub> / (R <sub>2</sub> ) <sup>(1)</sup>
-13	1.044	(12.7) kΩ	(11.1) kΩ
-12	1.056	(15.7) kΩ	(13.4) kΩ
-11	1.068	(19.2) kΩ	(16.1) kΩ
-10	1.080	(23.4) kΩ	(19.4) kΩ
-9	1.092	(28.6) kΩ	(23.4) kΩ
-8	1.104	(35) kΩ	(28.4) kΩ
-7	1.116	(43.2) kΩ	(34.8) kΩ
-6	1.128	(54.2) kΩ	(43.4) kΩ
-5	1.140	(69.7) kΩ	(55.4) kΩ
-4	1.152	(92.8) kΩ	(73.4) kΩ
-3	1.164	(131) kΩ	103.0) kΩ
-2	1.176	(208) kΩ	163.0) kΩ
-1	1.188	(440) kΩ	343.0) kΩ
0	1.200		
+ 1	1.212	148 kΩ	108.0 kΩ
+ 2	1.224	65.8 kΩ	48.0 kΩ
+ 3	1.236	38.4 kΩ	28.1 kΩ
+ 4	1.248	24.6 kΩ	18.1 kΩ
+ 5	1.260	16.4 kΩ	12.1 kΩ
+ 6	1.272	10.9 kΩ	8.1 kΩ
+ 7	1.284	7 kΩ	5.3 kΩ
+ 8	1.296	4.1 kΩ	3.2 kΩ
+ 9	1.308	1.8 kΩ	1.5 kΩ
+10	1.320	0 kΩ	0.2 kΩ

### CONFIGURING THE PTB4850X AND PTB4851X FOR DSL APPLICATIONS

When operated as a pair, the PTB4850x and PTB4851x converters are specifically designed to provide all the required supply voltages for powering xDSL chipsets. The PTB4850x produces two logic voltages. They include a 3.3-V source for logic and I/O, and a low-voltage for powering a digital signal processor core. The PTB4851x produces a balanced pair of complementary supply voltages that is required for the xDSL transceiver ICs. When used together in these types of applications, the PTB4850x and PTB4851x may be configured for power-up sequencing, and also synchronized to a common switch conversion frequency. Figure 20 shows the required cross-connects between the two converters to enable these two features.

### SWITCHING FREQUENCY SYNCHRONIZATION

Unsynchronized, the difference in switch frequency introduces a beat frequency into the input and output AC ripple components from the converters. The beat frequency can vary considerably with any slight variation in either converter's switch frequency. This results in a variable and undefined frequency spectrum for the ripple waveforms, which would normally require separate filters at the input of each converter. When the switch frequency of the converters are synchronized, the ripple components are constrained to the fundamental and higher. This simplifies the design of the output filters, and allows a common filter to be specified for the treatment of input ripple.

### POWER-UP SEQUENCING

The desired power-up sequence for the AC7 supply voltages requires that the two logic-level voltages from the PTB4850x converter rise to regulation prior to the two complementary voltages that power the transceiver ICs. This sequence cannot be guaranteed if the PTB4850x and PTB4851x are allowed to power up independently, especially if the 48-V input voltage rises relatively slowly. To ensure the desired power-up sequence, the *EN Out* pin of the PTB4850x is directly connected to the *activelow Enable* input of the PTB4851x (see Figure 20). This allows the PTB4850x to momentarily hold off the outputs from the PTB4851x until the logic-level voltages have risen first. Figure 19 shows the power-up waveforms of all four supply voltages from the schematic of Figure 20.

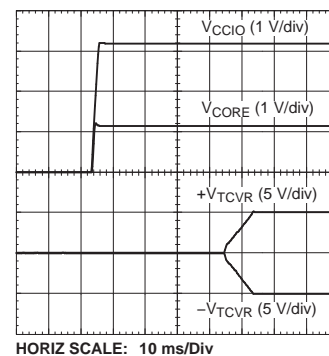

Figure 19. Power-Up Sequencing Waveforms

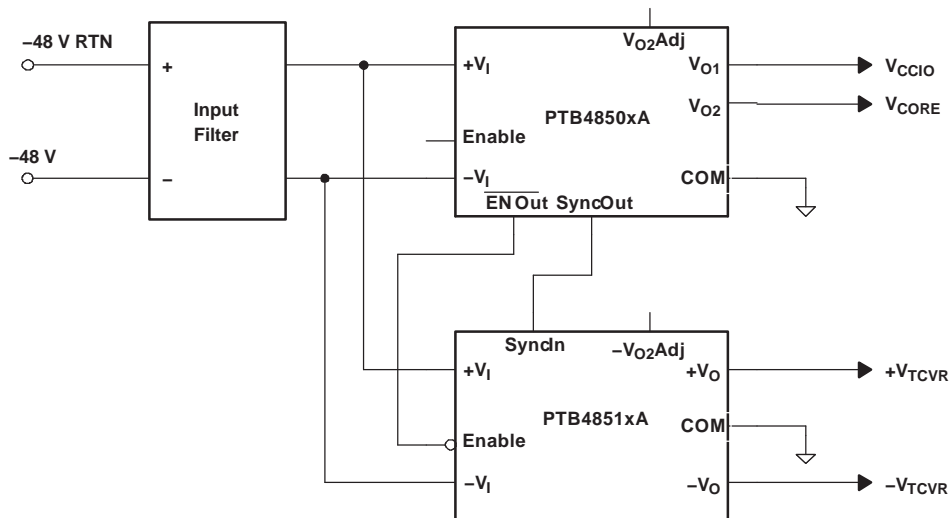

Figure 20. Example of PTB4850x and PTB4851x Modules Configured for DSL Applications

**PACKAGING INFORMATION**

Orderable Device	Status (1)	Package Type	Package Drawing	Pins	Package Qty	Eco Plan (2)	Lead/Ball Finish (6)	MSL Peak Temp (3)	Op Temp (°C)	Device Marking (4/5)	Samples
PTB48502AAZ	NRND	Surface Mount Module	ERJ	10	9	Pb-Free (RoHS)	SNAGCU	Level-3-260C-168 HR	-40 to 85		

(1) The marketing status values are defined as follows:

**ACTIVE:** Product device recommended for new designs.

**LIFEBUY:** TI has announced that the device will be discontinued, and a lifetime-buy period is in effect.

**NRND:** Not recommended for new designs. Device is in production to support existing customers, but TI does not recommend using this part in a new design.

**PREVIEW:** Device has been announced but is not in production. Samples may or may not be available.

**OBSELETE:** TI has discontinued the production of the device.

(2) Eco Plan - The planned eco-friendly classification: Pb-Free (RoHS), Pb-Free (RoHS Exempt), or Green (RoHS & no Sb/Br) - please check <http://www.ti.com/productcontent> for the latest availability information and additional product content details.

**TBD:** The Pb-Free/Green conversion plan has not been defined.

**Pb-Free (RoHS):** TI's terms "Lead-Free" or "Pb-Free" mean semiconductor products that are compatible with the current RoHS requirements for all 6 substances, including the requirement that lead not exceed 0.1% by weight in homogeneous materials. Where designed to be soldered at high temperatures, TI Pb-Free products are suitable for use in specified lead-free processes.

**Pb-Free (RoHS Exempt):** This component has a RoHS exemption for either 1) lead-based flip-chip solder bumps used between the die and package, or 2) lead-based die adhesive used between the die and leadframe. The component is otherwise considered Pb-Free (RoHS compatible) as defined above.

**Green (RoHS & no Sb/Br):** TI defines "Green" to mean Pb-Free (RoHS compatible), and free of Bromine (Br) and Antimony (Sb) based flame retardants (Br or Sb do not exceed 0.1% by weight in homogeneous material)

(3) MSL, Peak Temp. - The Moisture Sensitivity Level rating according to the JEDEC industry standard classifications, and peak solder temperature.

(4) There may be additional marking, which relates to the logo, the lot trace code information, or the environmental category on the device.

(5) Multiple Device Markings will be inside parentheses. Only one Device Marking contained in parentheses and separated by a "-" will appear on a device. If a line is indented then it is a continuation of the previous line and the two combined represent the entire Device Marking for that device.

(6) Lead/Ball Finish - Orderable Devices may have multiple material finish options. Finish options are separated by a vertical ruled line. Lead/Ball Finish values may wrap to two lines if the finish value exceeds the maximum column width.

**Important Information and Disclaimer:**The information provided on this page represents TI's knowledge and belief as of the date that it is provided. TI bases its knowledge and belief on information provided by third parties, and makes no representation or warranty as to the accuracy of such information. Efforts are underway to better integrate information from third parties. TI has taken and continues to take reasonable steps to provide representative and accurate information but may not have conducted destructive testing or chemical analysis on incoming materials and chemicals. TI and TI suppliers consider certain information to be proprietary, and thus CAS numbers and other limited information may not be available for release.

In no event shall TI's liability arising out of such information exceed the total purchase price of the TI part(s) at issue in this document sold by TI to Customer on an annual basis.



ERJ (R-PDSS-B10)

DOUBLE SIDED MODULE

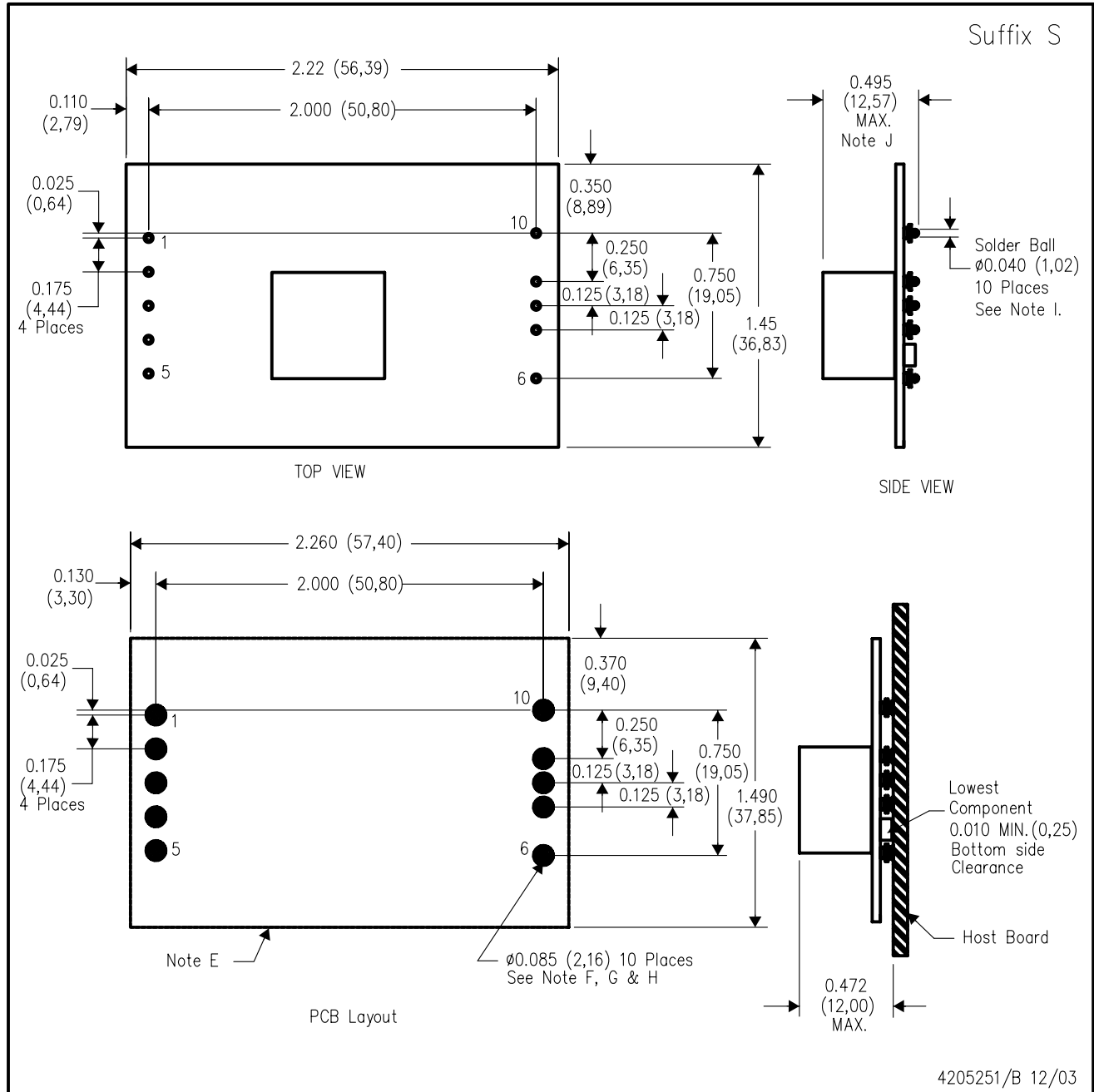

- NOTES:
- A. All linear dimensions are in inches (mm).
  - B. This drawing is subject to change without notice.
  - C. 2 place decimals are  $\pm 0.020$  ( $\pm 0,51$ mm).
  - D. 3 place decimals are  $\pm 0.010$  ( $\pm 0,25$ mm).
  - E. Recommended keep out area for user components.
  - F. Power pin connection should utilize four or more vias to the interior power plane of 0.025 (0,63) I.D. per input, ground and output pin (or the electrical equivalent).
  - G. Paste screen opening: 0.080 (2,03) to 0.085 (2,16). Paste screen thickness: 0.006 (0,15).
  - H. Pad type: Solder mask defined.
  - I. All pins: Material – Copper Alloy  
Finish – Tin (100%) over Nickel plate  
Solder Ball – See product data sheet.
  - J. Dimension prior to reflow solder.

## IMPORTANT NOTICE

Texas Instruments Incorporated and its subsidiaries (TI) reserve the right to make corrections, enhancements, improvements and other changes to its semiconductor products and services per JESD46, latest issue, and to discontinue any product or service per JESD48, latest issue. Buyers should obtain the latest relevant information before placing orders and should verify that such information is current and complete. All semiconductor products (also referred to herein as "components") are sold subject to TI's terms and conditions of sale supplied at the time of order acknowledgment.

TI warrants performance of its components to the specifications applicable at the time of sale, in accordance with the warranty in TI's terms and conditions of sale of semiconductor products. Testing and other quality control techniques are used to the extent TI deems necessary to support this warranty. Except where mandated by applicable law, testing of all parameters of each component is not necessarily performed.

TI assumes no liability for applications assistance or the design of Buyers' products. Buyers are responsible for their products and applications using TI components. To minimize the risks associated with Buyers' products and applications, Buyers should provide adequate design and operating safeguards.

TI does not warrant or represent that any license, either express or implied, is granted under any patent right, copyright, mask work right, or other intellectual property right relating to any combination, machine, or process in which TI components or services are used. Information published by TI regarding third-party products or services does not constitute a license to use such products or services or a warranty or endorsement thereof. Use of such information may require a license from a third party under the patents or other intellectual property of the third party, or a license from TI under the patents or other intellectual property of TI.

Reproduction of significant portions of TI information in TI data books or data sheets is permissible only if reproduction is without alteration and is accompanied by all associated warranties, conditions, limitations, and notices. TI is not responsible or liable for such altered documentation. Information of third parties may be subject to additional restrictions.

Resale of TI components or services with statements different from or beyond the parameters stated by TI for that component or service voids all express and any implied warranties for the associated TI component or service and is an unfair and deceptive business practice. TI is not responsible or liable for any such statements.

Buyer acknowledges and agrees that it is solely responsible for compliance with all legal, regulatory and safety-related requirements concerning its products, and any use of TI components in its applications, notwithstanding any applications-related information or support that may be provided by TI. Buyer represents and agrees that it has all the necessary expertise to create and implement safeguards which anticipate dangerous consequences of failures, monitor failures and their consequences, lessen the likelihood of failures that might cause harm and take appropriate remedial actions. Buyer will fully indemnify TI and its representatives against any damages arising out of the use of any TI components in safety-critical applications.

In some cases, TI components may be promoted specifically to facilitate safety-related applications. With such components, TI's goal is to help enable customers to design and create their own end-product solutions that meet applicable functional safety standards and requirements. Nonetheless, such components are subject to these terms.

No TI components are authorized for use in FDA Class III (or similar life-critical medical equipment) unless authorized officers of the parties have executed a special agreement specifically governing such use.

Only those TI components which TI has specifically designated as military grade or "enhanced plastic" are designed and intended for use in military/aerospace applications or environments. Buyer acknowledges and agrees that any military or aerospace use of TI components which have **not** been so designated is solely at the Buyer's risk, and that Buyer is solely responsible for compliance with all legal and regulatory requirements in connection with such use.

TI has specifically designated certain components as meeting ISO/TS16949 requirements, mainly for automotive use. In any case of use of non-designated products, TI will not be responsible for any failure to meet ISO/TS16949.

### Products

Audio	<a href="http://www.ti.com/audio">www.ti.com/audio</a>
Amplifiers	<a href="http://amplifier.ti.com">amplifier.ti.com</a>
Data Converters	<a href="http://dataconverter.ti.com">dataconverter.ti.com</a>
DLP® Products	<a href="http://www.dlp.com">www.dlp.com</a>
DSP	<a href="http://dsp.ti.com">dsp.ti.com</a>
Clocks and Timers	<a href="http://www.ti.com/clocks">www.ti.com/clocks</a>
Interface	<a href="http://interface.ti.com">interface.ti.com</a>
Logic	<a href="http://logic.ti.com">logic.ti.com</a>
Power Mgmt	<a href="http://power.ti.com">power.ti.com</a>
Microcontrollers	<a href="http://microcontroller.ti.com">microcontroller.ti.com</a>
RFID	<a href="http://www.ti-rfid.com">www.ti-rfid.com</a>
OMAP Applications Processors	<a href="http://www.ti.com/omap">www.ti.com/omap</a>
Wireless Connectivity	<a href="http://www.ti.com/wirelessconnectivity">www.ti.com/wirelessconnectivity</a>

### Applications

Automotive and Transportation	<a href="http://www.ti.com/automotive">www.ti.com/automotive</a>
Communications and Telecom	<a href="http://www.ti.com/communications">www.ti.com/communications</a>
Computers and Peripherals	<a href="http://www.ti.com/computers">www.ti.com/computers</a>
Consumer Electronics	<a href="http://www.ti.com/consumer-apps">www.ti.com/consumer-apps</a>
Energy and Lighting	<a href="http://www.ti.com/energy">www.ti.com/energy</a>
Industrial	<a href="http://www.ti.com/industrial">www.ti.com/industrial</a>
Medical	<a href="http://www.ti.com/medical">www.ti.com/medical</a>
Security	<a href="http://www.ti.com/security">www.ti.com/security</a>
Space, Avionics and Defense	<a href="http://www.ti.com/space-avionics-defense">www.ti.com/space-avionics-defense</a>
Video and Imaging	<a href="http://www.ti.com/video">www.ti.com/video</a>

### TI E2E Community

[e2e.ti.com](http://e2e.ti.com)

## Looking for pricing, stock, or lifecycle information?

Click below to explore more details on WIN SOURCE:

 [View PTB48500AAS](#) on WIN SOURCE

 [Texas Instruments](#) Information

## Optimize Your Supply Chain with WIN SOURCE Solutions

-  Global Sourcing Solution
-  Obsolete Management
-  Cost Control Management
-  Shortage Management
-  Alternative Solution
-  Excess Inventory Management