



THE DATASHEET OF OPA1641AID



OPA164x SoundPlus™ High-Performance, JFET-Input Audio Operational Amplifiers

1 Features

- Superior Sound Quality
- True JFET Input Operational Amplifier With Low Input Bias Current
- Low Noise: 5.1 nV/ $\sqrt{\text{Hz}}$ at 1 kHz
- Ultralow Distortion: 0.00005% at 1 kHz
- High Slew Rate: 20 V/ μs
- Unity Gain Stable
- No Phase Reversal
- Low Quiescent Current: 1.8 mA per Channel
- Rail-to-rail Output
- Wide Supply Range: $\pm 2.25\text{ V}$ to $\pm 18\text{ V}$
- Single, Dual, and Quad Versions Available

2 Applications

- Professional Audio Equipment
- Analog and Digital Mixing Consoles
- Broadcast Studio Equipment
- High-End A/V Receivers
- High-End Blu-ray™ Players

3 Description

The OPA1641 (single), OPA1642 (dual), and OPA1644 (quad) series are JFET-input, ultralow distortion, low-noise operational amplifiers fully specified for audio applications.

The OPA1641, OPA1642, and OPA1644 rail-to-rail output swing allows increased headroom, making these devices ideal for use in any audio circuit. Features include 5.1-nV/ $\sqrt{\text{Hz}}$ noise, low THD+N (0.00005%), a low input bias current of 2 pA, and low quiescent current of 1.8 mA per channel.

These devices operate over a very wide supply voltage range of $\pm 2.25\text{ V}$ to $\pm 18\text{ V}$. The OPA1641, OPA1642, and OPA1644 series of operational amplifiers are unity-gain stable and provide excellent dynamic behavior over a wide range of load conditions.

The dual and quad versions feature completely independent circuitry for lowest crosstalk and freedom from interactions between channels, even when overdriven or overloaded.

The OPA1641, OPA1642, and OPA1644 are specified from -40°C to $+85^\circ\text{C}$.

Device Information⁽¹⁾

PART NUMBER	PACKAGE	BODY SIZE (NOM)
OPA1641	SOIC (8)	4.90 mm x 3.90 mm
	VSSOP (8)	3.00 mm x 3.00 mm
OPA1642	SOIC (8)	4.90 mm x 3.90 mm
	VSSOP (8)	3.00 mm x 3.00 mm
OPA1644	SOIC (14)	8.65 mm x 3.90 mm
	TSSOP (14)	5.00 mm x 4.40 mm

(1) For all available packages, see the orderable addendum at the end of the data sheet.

Simplified Internal Schematic

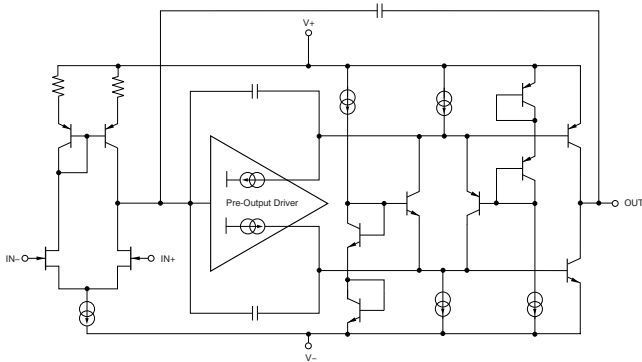

Extremely Stable Input Capacitance

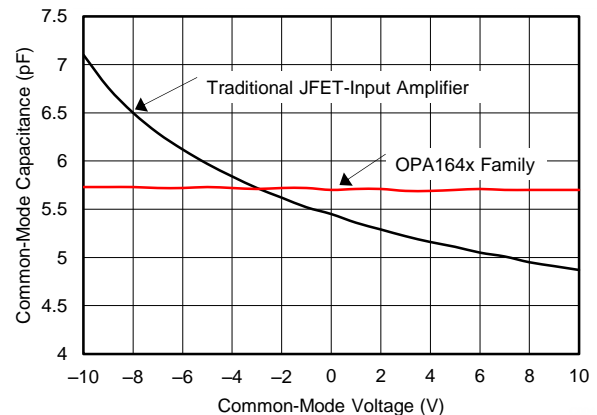

Table of Contents

1 Features 1 2 Applications 1 3 Description 1 4 Revision History 2 5 Pin Configuration and Functions 4 6 Specifications 6 6.1 Absolute Maximum Ratings 6 6.2 ESD Ratings 6 6.3 Recommended Operating Conditions 6 6.4 Thermal Information 6 6.5 Electrical Characteristics 7 6.6 Typical Characteristics 9 7 Detailed Description 14 7.1 Overview 14 7.2 Functional Block Diagram 14 7.3 Feature Description 15 7.4 Device Functional Modes 17	8 Application and Implementation 18 8.1 Application Information 18 8.2 Typical Application 25 9 Power Supply Recommendations 27 10 Layout 28 10.1 Layout Guidelines 28 10.2 Layout Example 29 11 Device and Documentation Support 30 11.1 Device Support 30 11.2 Documentation Support 30 11.3 Related Links 31 11.4 Community Resources 31 11.5 Trademarks 31 11.6 Electrostatic Discharge Caution 31 11.7 Glossary 31 12 Mechanical, Packaging, and Orderable Information 31
---	--

4 Revision History

NOTE: Page numbers for previous revisions may differ from page numbers in the current version.

Changes from Revision C (December 2015) to Revision D	Page
• Added TI Design	1
• Changed MSOP to VSSOP throughout document	1
• Changed <i>Supply voltage</i> parameter in <i>Recommended Operating Conditions</i> table to split single and dual supply specifications into separate rows for clarity	6
• Changed last column header in <i>Thermal Information</i> table from <i>DGK (VSSOP)</i> to <i>PW (TSSOP)</i>	6
• Changed <i>Noise</i> subsection of <i>Electrical Characteristics</i> table: changed <i>Input voltage noise</i> parameter typical specification and changed first two e_n parameter typical specifications	7
• Changed <i>Input Bias Current</i> subsection of <i>Electrical Characteristics</i> table	7
• Changed V_O parameter test conditions in <i>Electrical Characteristics</i> table	8
• Added I_{SC} parameter specifications to <i>Electrical Characteristics</i> table	8
• Changed <i>Temperature Range</i> subsection of <i>Electrical Characteristics</i> table	8
• Changed third paragraph of <i>Power Dissipation and Thermal Protection</i> section for clarity	23
• Changed second paragraph of <i>Electrical Overstress</i> section for clarity	23
• Added text reference for Equation 5	27

Changes from Revision B (August 2010) to Revision C	Page
• Added <i>Pin Configuration and Functions</i> section, <i>ESD Ratings</i> table, <i>Feature Description</i> section, <i>Device Functional Modes</i> , <i>Application and Implementation</i> section, <i>Power Supply Recommendations</i> section, <i>Layout</i> section, <i>Device and Documentation Support</i> section, and <i>Mechanical, Packaging, and Orderable Information</i> section	1
• Added text to last bullet of <i>Layout Guidelines</i> section	28

Changes from Revision A (April 2010) to Revision B	Page
• Removed product-preview information for MSOP-8 package version of OPA1641	1

Changes from Original (December 2009) to Revision A**Page**

-
- Removed product-preview information for OPA1644 device packages throughout document..... **1**
-

5 Pin Configuration and Functions

**OPA1641: D and DGK Packages
8-Pin SOIC and VSSOP
Top View**

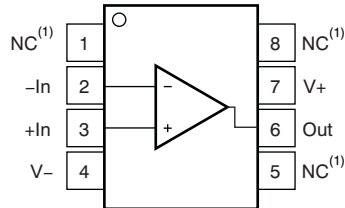

(1) NC denotes no internal connection.

Pin Functions: OPA1641

PIN		I/O	DESCRIPTION
NO.	NAME		
1	NC	—	No connection
2	–IN	I	Inverting input
3	+IN	I	Noninverting input
4	V–	—	Negative (lowest) power supply
5	NC	—	No connection
6	OUT	O	Output
7	V+	—	Positive (highest) power supply
8	NC	—	No connection

**OPA1642: D and DGK Packages
8-Pin SOIC and VSSOP
Top View**

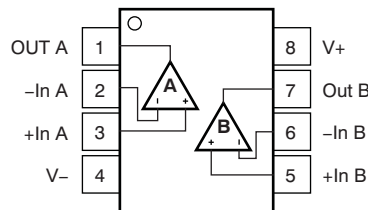

Pin Functions: OPA1642

PIN		I/O	DESCRIPTION
NO.	NAME		
1	OUT A	O	Output, channel A
2	–IN A	I	Inverting input, channel A
3	+IN A	I	Noninverting input, channel A
4	V–	—	Negative (lowest) power supply
5	+IN B	I	Noninverting input, channel B
6	–IN B	I	Inverting input, channel B
7	OUT B	O	Output, channel B
8	V+	—	Positive (highest) power supply

**OPA1644: D and PW Packages
14-Pin SOIC and TSSOP
Top View**

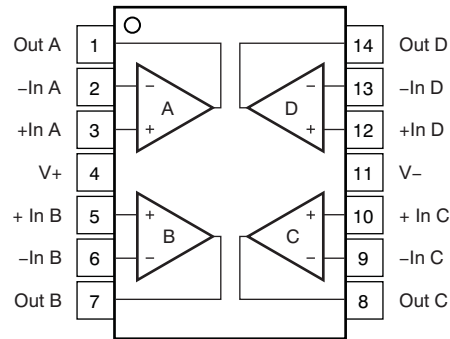

Pin Functions: OPA1644

PIN		I/O	DESCRIPTION
NO.	NAME		
1	OUT A	O	Output, channel A
2	-IN A	I	Inverting input, channel A
3	+IN A	I	Noninverting input, channel A
4	V+	—	Positive (highest) power supply
5	+IN B	I	Noninverting input, channel B
6	-IN B	I	Inverting input, channel B
7	OUT B	O	Output, channel B
8	OUT C	O	Output, channel C
9	-IN C	I	Inverting input, channel C
10	+IN C	I	Noninverting input, channel C
11	V-	—	Negative (lowest) power supply
12	+IN D	I	Noninverting input, channel D
13	-IN D	I	Inverting input, channel D
14	OUT D	O	Output, channel D

6 Specifications

6.1 Absolute Maximum Ratings

 over operating free-air temperature range (unless otherwise noted)⁽¹⁾

		MIN	MAX	UNIT
V _S	Supply voltage		40	V
V _{IN}	Input voltage ⁽²⁾	(V ⁻) – 0.5	(V ⁺) + 0.5	V
I _{IN}	Input current ⁽²⁾		±10	mA
V _{IN(DIFF)}	Differential input voltage		±V _S	V
I _O	Output short-circuit ⁽³⁾	Continuous		
T _A	Operating temperature	–55	125	°C
T _J	Junction temperature	–65	150	°C
T _{stg}	Storage temperature	–65	150	°C

- (1) Stresses beyond those listed under *Absolute Maximum Ratings* may cause permanent damage to the device. These are stress ratings only, which do not imply functional operation of the device at these or any other conditions beyond those indicated under *Recommended Operating Conditions*. Exposure to absolute-maximum-rated conditions for extended periods may affect device reliability.
- (2) Input pins are diode-clamped to the power-supply rails. Input signals that can swing more than 0.5 V beyond the supply rails must be current-limited to 10 mA or less. The input voltage and output negative-voltage ratings can be exceeded if the input and output current ratings are followed.
- (3) Short-circuit to V_S / 2 (ground in symmetrical dual-supply setups), one amplifier per package.

6.2 ESD Ratings

		VALUE	UNIT
V _(ESD)	Electrostatic discharge	Human-body model (HBM), per ANSI/ESDA/JEDEC JS-001 ⁽¹⁾	±3000
		Charged-device model (CDM), per JEDEC specification JESD22-C101 ⁽²⁾	±1000

- (1) JEDEC document JEP155 states that 500-V HBM allows safe manufacturing with a standard ESD control process.
- (2) JEDEC document JEP157 states that 250-V CDM allows safe manufacturing with a standard ESD control process.

6.3 Recommended Operating Conditions

over operating free-air temperature range (unless otherwise noted)

		MIN	NOM	MAX	UNIT
Supply voltage (V ⁺ , V ⁻)	Single supply	4.5		36	V
	Dual supply	±2.25		±18	
Specified temperature		–40		85	°C

6.4 Thermal Information

THERMAL METRIC ⁽¹⁾	OPA1641, OPA1642		OPA1644		UNIT	
	D (SOIC)	DGK (VSSOP)	D (SOIC)	PW (TSSOP)		
	8 PINS	8 PINS	14 PINS	14 PINS		
R _{θJA}	Junction-to-ambient thermal resistance	160	180	97	135	°C/W
R _{θJC(top)}	Junction-to-case (top) thermal resistance	75	55	56	45	°C/W
R _{θJB}	Junction-to-board thermal resistance	60	130	53	66	°C/W
ψ _{JT}	Junction-to-top characterization parameter	9	n/a	19	n/a	°C/W
ψ _{JB}	Junction-to-board characterization parameter	50	120	46	60	°C/W
R _{θJC(bot)}	Junction-to-case (bottom) thermal resistance	n/a	n/a	n/a	n/a	°C/W

- (1) For more information about traditional and new thermal metrics, see the *Semiconductor and IC Package Thermal Metrics* application report, [SPRA953](#).

6.5 Electrical Characteristics

at $T_A = 25^\circ\text{C}$, $V_S = 4.5\text{ V to }36 (\pm 2.25\text{ V to } \pm 18\text{ V})$, $R_L = 2\text{ k}\Omega$ connected to midsupply, and $V_{CM} = V_{OUT} = \text{midsupply}$ (unless otherwise noted)

PARAMETER		TEST CONDITIONS	MIN	TYP	MAX	UNIT	
AUDIO PERFORMANCE							
THD+N	Total harmonic distortion + noise	$G = +1$, $f = 1\text{ kHz}$, $V_O = 3\text{ V}_{RMS}$	0.00005%				
				-126		dB	
IMD	Intermodulation distortion	SMPTE/DIN two-tone, 4:1 (60 Hz and 7 kHz), $G = +1$, $V_O = 3\text{ V}_{RMS}$	0.00004%				
				-128		dB	
		DIM 30 (3-kHz square wave and 15-kHz sine wave), $G = +1$, $V_O = 3\text{ V}_{RMS}$	0.00008%				
				-122		dB	
CCIF twin-tone (19 kHz and 20 kHz), $G = +1$, $V_O = 3\text{ V}_{RMS}$	0.00007%						
		-123		dB			
FREQUENCY RESPONSE							
GBW	Gain-bandwidth product	$G = 1$		11		MHz	
SR	Slew rate	$G = 1$	20			V/ μs	
			Full-power bandwidth ⁽¹⁾		3.2		MHz
	Overload recovery time ⁽²⁾	$G = -10$	600			ns	
	Channel separation (dual and quad)	$f = 1\text{ kHz}$	-126			dB	
NOISE							
	Input voltage noise	$f = 20\text{ Hz to }20\text{ kHz}$	4.3			μV_{PP}	
e_n	Input voltage noise density	$f = 10\text{ Hz}$	8			nV/ $\sqrt{\text{Hz}}$	
		$f = 100\text{ Hz}$	5.8				
		$f = 1\text{ kHz}$	5.1				
i_n	Input current noise density	$f = 1\text{ kHz}$	0.8			fA/ $\sqrt{\text{Hz}}$	
OFFSET VOLTAGE							
V_{OS}	Input offset voltage	$V_S = \pm 18\text{ V}$		1	3.5	mV	
PSRR	V_{OS} vs power supply	$V_S = \pm 2.25\text{ V to } \pm 18\text{ V}$		0.14	2	$\mu\text{V/V}$	
INPUT BIAS CURRENT							
I_B	Input bias current	$V_{CM} = 0\text{ V}$		± 2	± 20	pA	
I_{OS}	Input offset current	$V_{CM} = 0\text{ V}$		± 2	± 20	pA	
INPUT VOLTAGE RANGE							
V_{CM}	Common-mode voltage range		(V-) - 0.1		(V+) - 3.5	V	
CMRR	Common-mode rejection ratio	$V_{CM} = (V-) - 0.1\text{ V to } (V+) - 3.5\text{ V}$, $V_S = \pm 18\text{ V}$	120	126		dB	
INPUT IMPEDANCE							
	Differential		$10^{13} \parallel 8$			$\Omega \parallel \text{pF}$	
	Common-mode	$V_{CM} = (V-) - 0.1\text{ V to } (V+) - 3.5\text{ V}$	$10^{13} \parallel 6$			$\Omega \parallel \text{pF}$	
OPEN-LOOP GAIN							
A_{OL}	Open-loop voltage gain	$(V-) + 0.2\text{ V} \leq V_O \leq (V+) - 0.2\text{ V}$, $R_L = 10\text{ k}\Omega$	120	134		dB	
		$(V-) + 0.35\text{ V} \leq V_O \leq (V+) - 0.35\text{ V}$, $R_L = 2\text{ k}\Omega$	114	126			

(1) Full power bandwidth = $SR / (2\pi \times V_P)$, where SR = slew rate.

(2) See [Figure 19](#) and [Figure 20](#).

Electrical Characteristics (continued)

 at $T_A = 25^\circ\text{C}$, $V_S = 4.5\text{ V to }36 (\pm 2.25\text{ V to } \pm 18\text{ V})$, $R_L = 2\text{ k}\Omega$ connected to midsupply, and $V_{CM} = V_{OUT} = \text{midsupply}$ (unless otherwise noted)

PARAMETER		TEST CONDITIONS	MIN	TYP	MAX	UNIT
OUTPUT						
V_O	Voltage output swing from rail	$R_L = 10\text{ k}\Omega$, $A_{OL} \geq 120\text{ dB}$	$(V^-)+0.2$		$(V^+)-0.2$	V
		$R_L = 2\text{ k}\Omega$, $A_{OL} \geq 114\text{ dB}$	$(V^-)+0.35$		$(V^+)-0.35$	
I_{OUT}	Output current		See Typical Characteristics			
Z_O	Open-loop output impedance		See Typical Characteristics			
I_{SC}	Short-circuit current	Source		36		mA
		Sink		-30		
C_{LOAD}	Capacitive load drive		See Typical Characteristics			
POWER SUPPLY						
V_S	Specified voltage		± 2.25		± 18	V
I_Q	Quiescent current (per amplifier)	$I_{OUT} = 0\text{ A}$		1.8	2.3	mA
TEMPERATURE RANGE						
	Specified range		-40		85	$^\circ\text{C}$
	Operating range		-55		125	$^\circ\text{C}$
Thermal resistance		8-pin SOIC package		138		$^\circ\text{C/W}$
		8-pin VSSOP package		180		
		14-pin SOIC package		97		
		14-pin TSSOP package		135		

6.6 Typical Characteristics

at $T_A = 25^\circ\text{C}$, $R_L = 2\text{ k}\Omega$ connected to midsupply, and $V_{CM} = V_{OUT} = \text{midsupply}$ (unless otherwise noted)

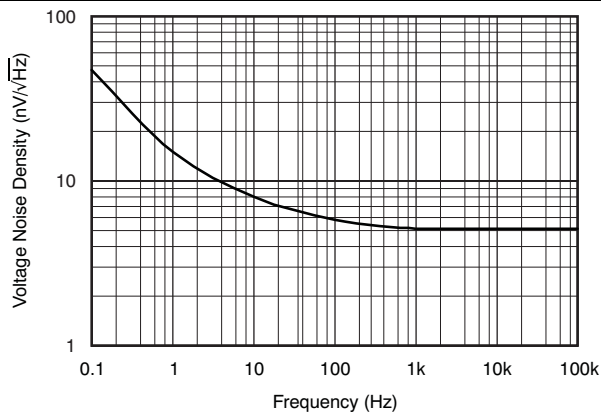

Figure 1. Input Voltage Noise Density vs Frequency

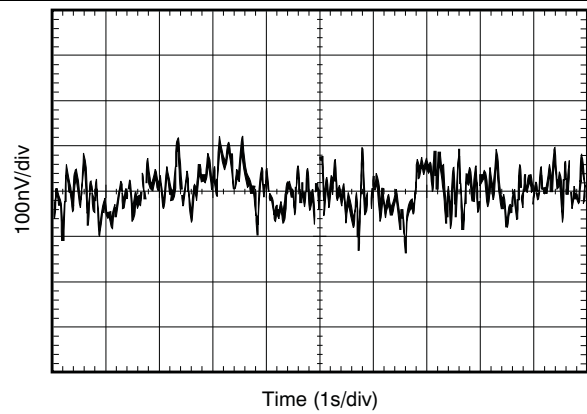

Figure 2. 0.1-Hz to 10-Hz Noise

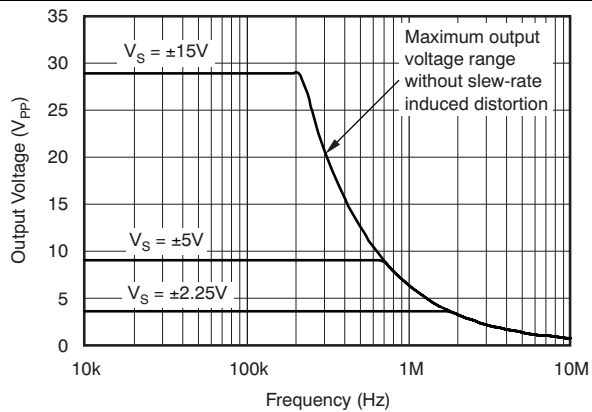

Figure 3. Maximum Output Voltage vs Frequency

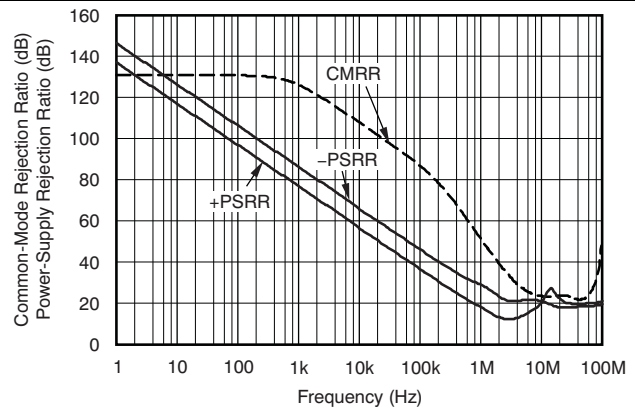

Figure 4. CMRR and PSRR vs Frequency (Referred to Input)

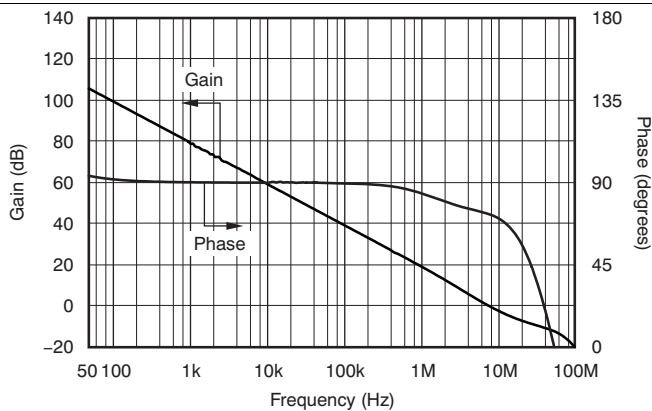

Figure 5. Gain and Phase vs Frequency

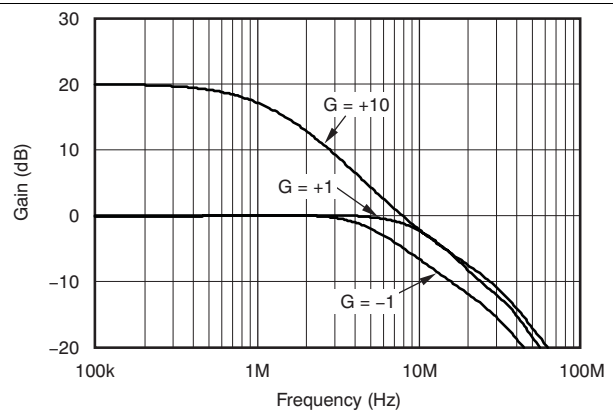

Figure 6. Closed-Loop Gain vs Frequency

Typical Characteristics (continued)

at $T_A = 25^\circ\text{C}$, $R_L = 2\text{ k}\Omega$ connected to midsupply, and $V_{CM} = V_{OUT} = \text{midsupply}$ (unless otherwise noted)

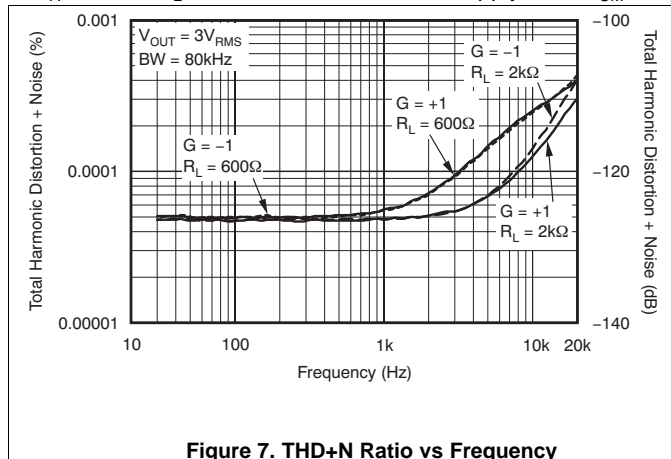

Figure 7. THD+N Ratio vs Frequency

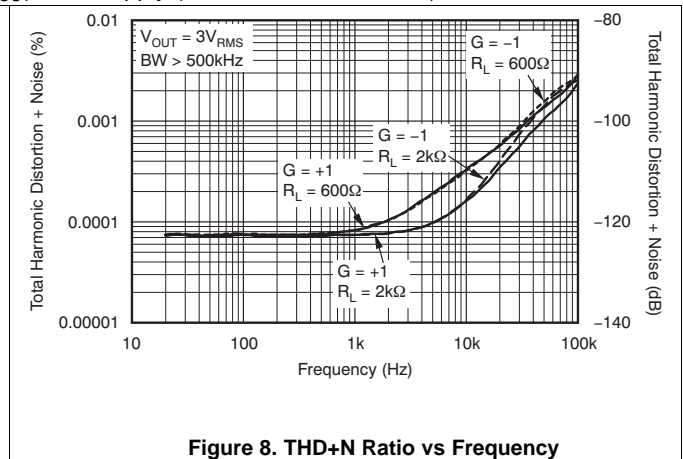

Figure 8. THD+N Ratio vs Frequency

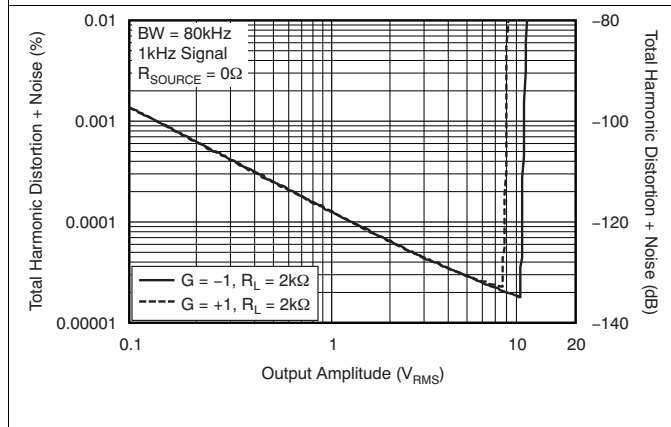

Figure 9. THD+N Ratio vs Output Amplitude

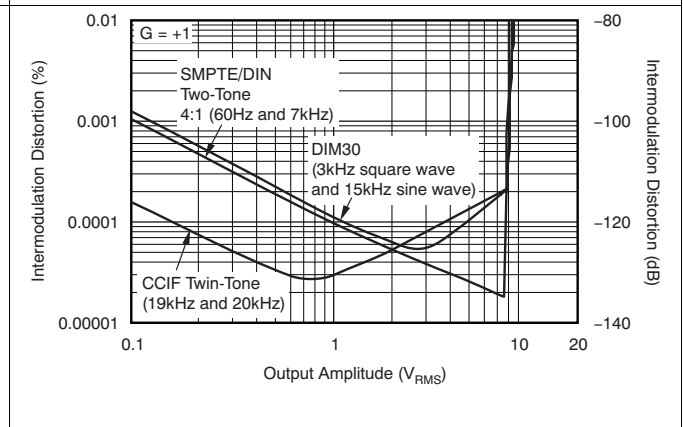

Figure 10. Intermodulation Distortion vs Output Amplitude

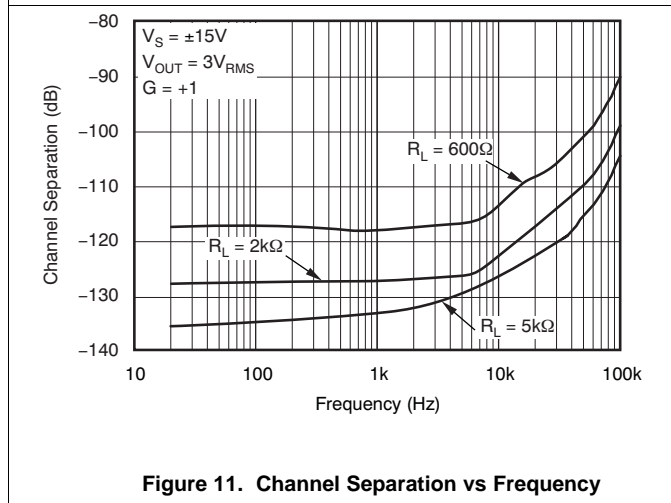

Figure 11. Channel Separation vs Frequency

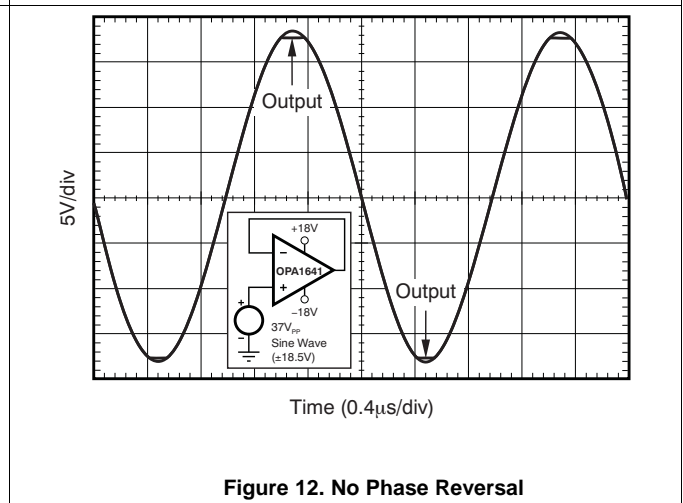

Figure 12. No Phase Reversal

Typical Characteristics (continued)

at $T_A = 25^\circ\text{C}$, $R_L = 2\text{ k}\Omega$ connected to midsupply, and $V_{CM} = V_{OUT} = \text{midsupply}$ (unless otherwise noted)

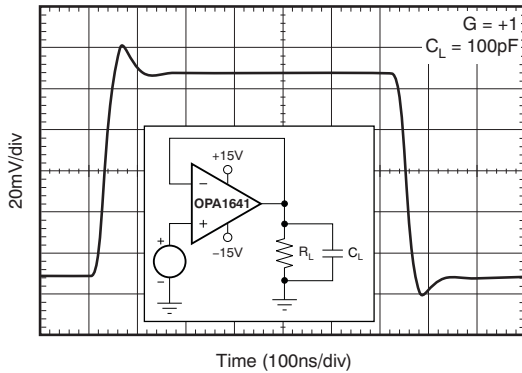

Figure 13. Small-Signal Step Response (100 mV)

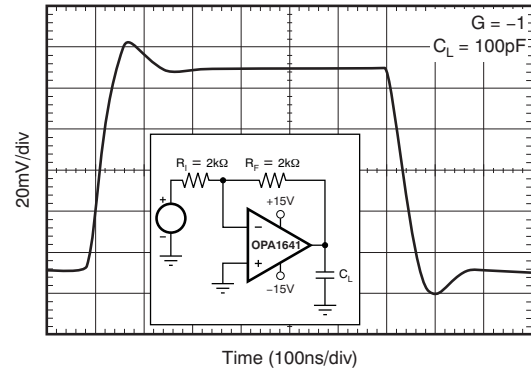

Figure 14. Small-Signal Step Response (100 mV)

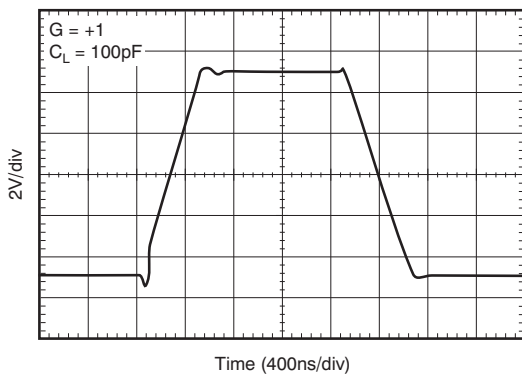

Figure 15. Large-Signal Step Response

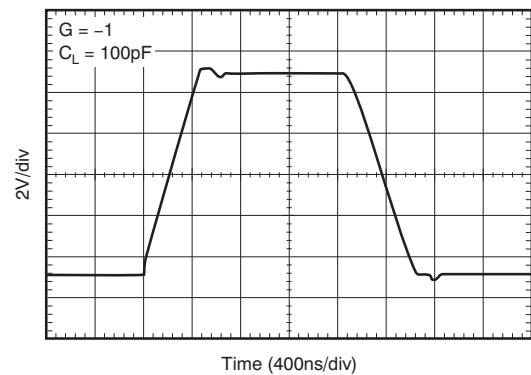

Figure 16. Large-Signal Step Response

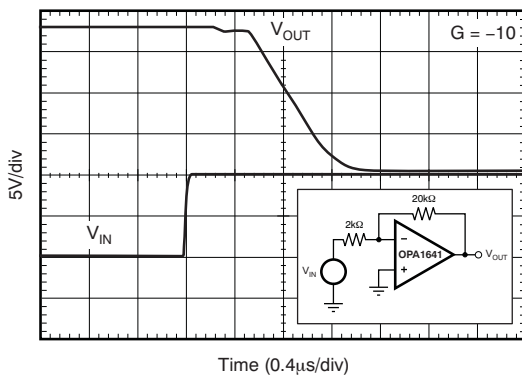

Figure 17. Positive Overload Recovery

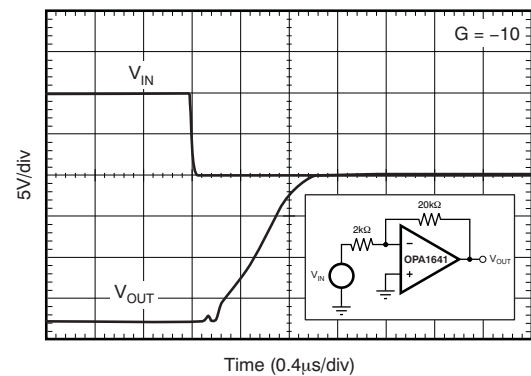

Figure 18. Negative Overload Recovery

Typical Characteristics (continued)

at $T_A = 25^\circ\text{C}$, $R_L = 2\text{ k}\Omega$ connected to midsupply, and $V_{CM} = V_{OUT} = \text{midsupply}$ (unless otherwise noted)

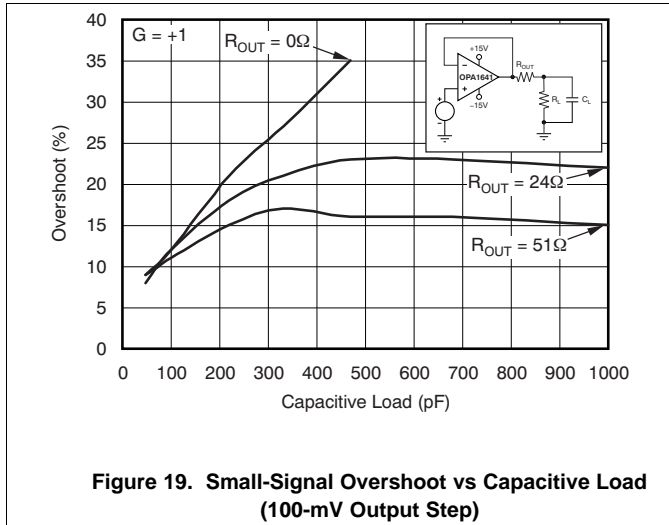

Figure 19. Small-Signal Overshoot vs Capacitive Load (100-mV Output Step)

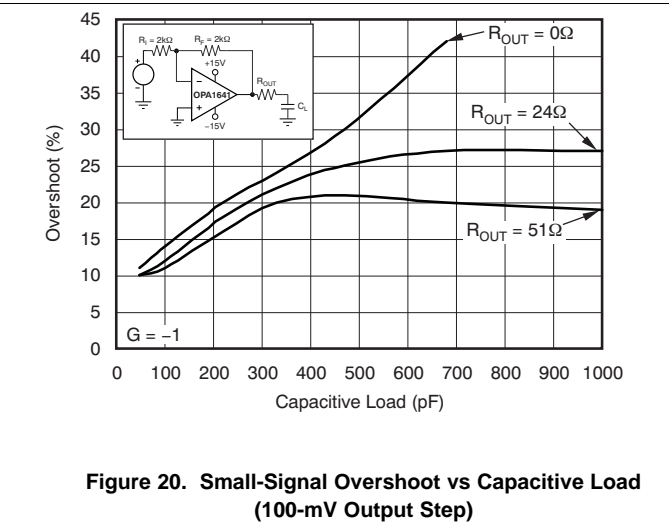

Figure 20. Small-Signal Overshoot vs Capacitive Load (100-mV Output Step)

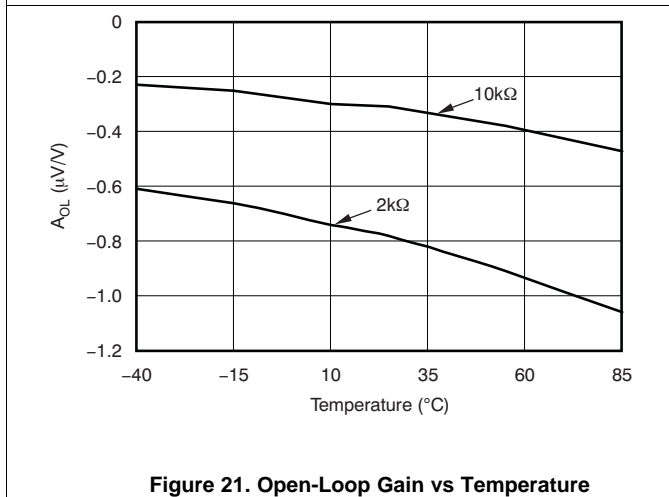

Figure 21. Open-Loop Gain vs Temperature

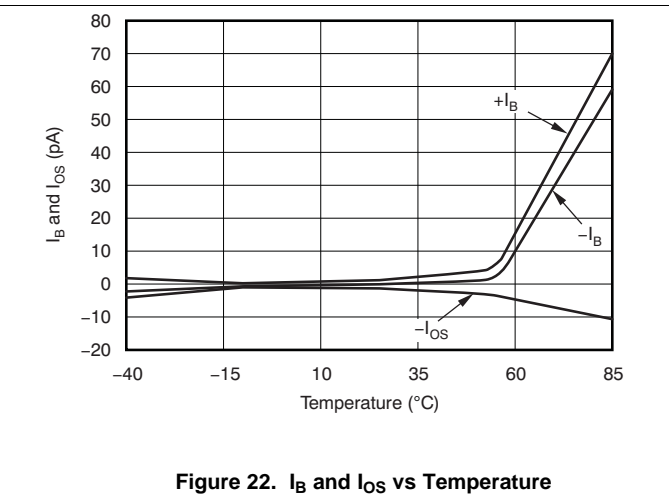

Figure 22. I_B and I_{OS} vs Temperature

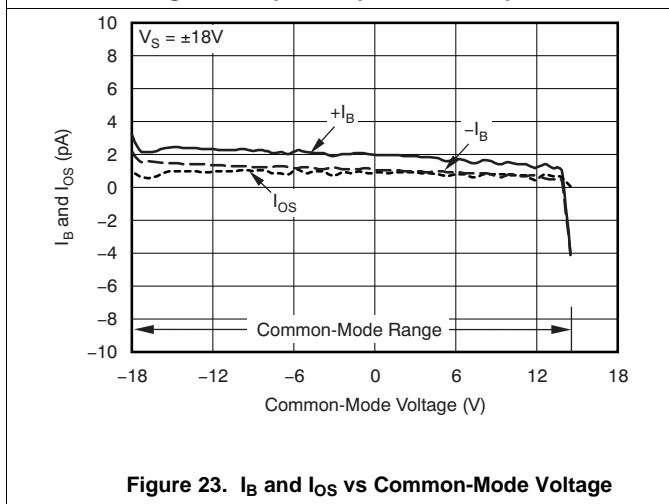

Figure 23. I_B and I_{OS} vs Common-Mode Voltage

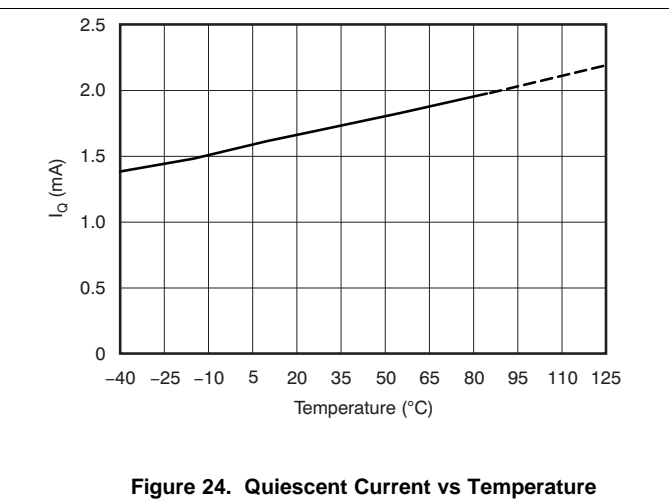
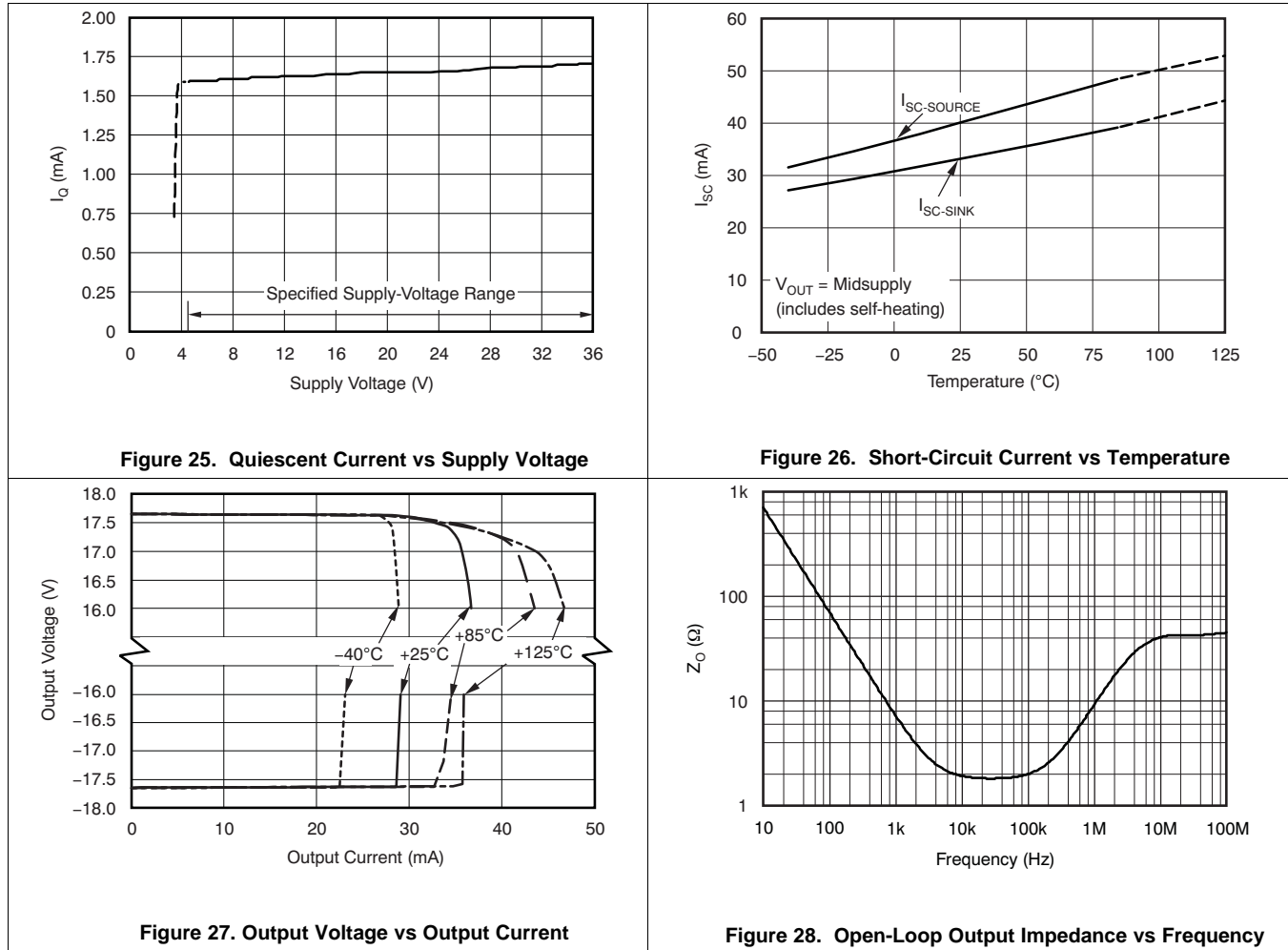

Figure 24. Quiescent Current vs Temperature

Typical Characteristics (continued)

at $T_A = 25^\circ\text{C}$, $R_L = 2\text{ k}\Omega$ connected to midsupply, and $V_{CM} = V_{OUT} = \text{midsupply}$ (unless otherwise noted)



7 Detailed Description

7.1 Overview

The OPA164x family of operational amplifiers combine an ultra low noise JFET input stage with a rail-to-rail output stage to provide high overall performance in audio applications. The internal topology is selected specifically to deliver extremely low distortion, consume limited power, and accommodate small packages. These amplifiers are well-suited for analog signal processing applications such as active filter circuits, pre-amplifiers, and tone controls. The unique input stage design and semiconductor processes used in this device deliver extremely high performance even in applications with high source impedance and wide common-mode voltage swings.

7.2 Functional Block Diagram

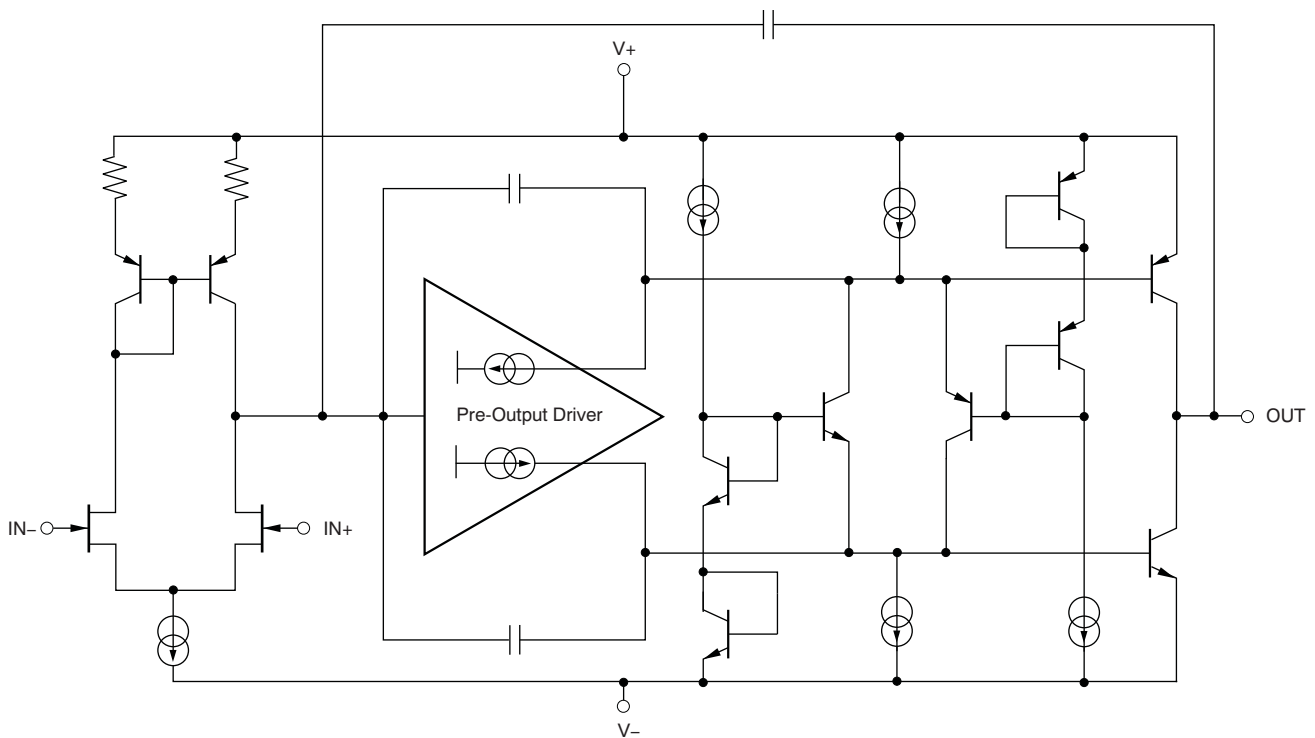

7.3 Feature Description

7.3.1 Phase Reversal Protection

The OPA164x family has internal phase-reversal protection. Many op amps exhibit phase reversal when the input is driven beyond the linear common-mode range. This condition is most often encountered in noninverting circuits when the input is driven beyond the specified common-mode voltage range, causing the output to reverse into the opposite rail. The input of the OPA164x prevents phase reversal with excessive common-mode voltage. Instead, the appropriate rail limits the output voltage. This performance is shown in Figure 29.

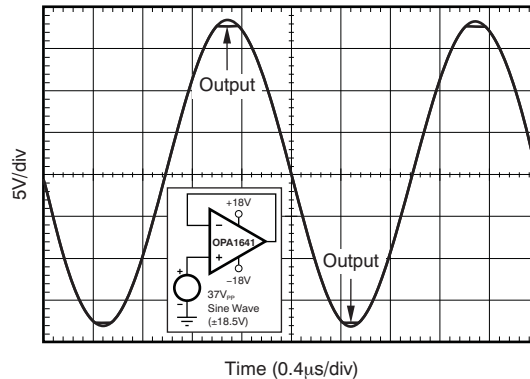

Figure 29. Output Waveform Devoid of Phase Reversal During an Input Overdrive Condition

7.3.2 Output Current Limit

The output current of the OPA164x series is limited by internal circuitry to 36 mA and –30 mA (sourcing and sinking), to protect the device if the output is accidentally shorted. This short-circuit current depends on temperature; see Figure 26.

Although uncommon for most modern audio applications to require 600-Ω load drive capability, many audio operational amplifier applications continue to specify the total harmonic distortion (THD+N) at 600-Ω load for comparative purposes. Figure 7 and Figure 8 provide typical THD+N measurement curves for the OPA164x series, where the output drives a 3- V_{RMS} signal into a 600-Ω load. However, correct device operation cannot be ensured when driving 600-Ω loads at full supply. Depending on supply voltage and temperature, this operating condition can possibly trigger the output current limit circuitry of the device.

7.3.3 EMI Rejection Ratio (EMIRR)

The electromagnetic interference (EMI) rejection ratio, or EMIRR, describes the EMI immunity of operational amplifiers. An adverse effect that is common to many operational amplifiers is a change in the offset voltage as a result of RF signal rectification. An operational amplifier that is more efficient at rejecting this change in offset as a result of EMI has a higher EMIRR and is quantified by a decibel value. Measuring EMIRR can be performed in many ways, but this document provides the EMIRR IN+, which specifically describes the EMIRR performance when the RF signal is applied to the noninverting input pin of the operational amplifier. In general, only the noninverting input is tested for EMIRR for the following three reasons:

- Operational amplifier input pins are known to be the most sensitive to EMI, and typically rectify RF signals better than the supply or output pins.
- The noninverting and inverting operational amplifier inputs have symmetrical physical layouts and exhibit nearly matching EMIRR performance.
- EMIRR is easier to measure on noninverting pins than on other pins because the noninverting input pin can be isolated on a printed-circuit-board (PCB). This isolation allows the RF signal to be applied directly to the noninverting input pin with no complex interactions from other components or connecting PCB traces.

A more formal discussion of the EMIRR IN+ definition and test method is provided in application report *EMI Rejection Ratio of Operational Amplifiers* (SBOA128), available for download at www.ti.com.

Feature Description (continued)

The EMIRR IN+ of the OPA164x is plotted versus frequency in [Figure 30](#). If available, any dual and quad operational amplifier device versions have nearly identical EMIRR IN+ performance. The OPA164x unity-gain bandwidth is 11 MHz. EMIRR performance below this frequency denotes interfering signals that fall within the operational amplifier bandwidth.

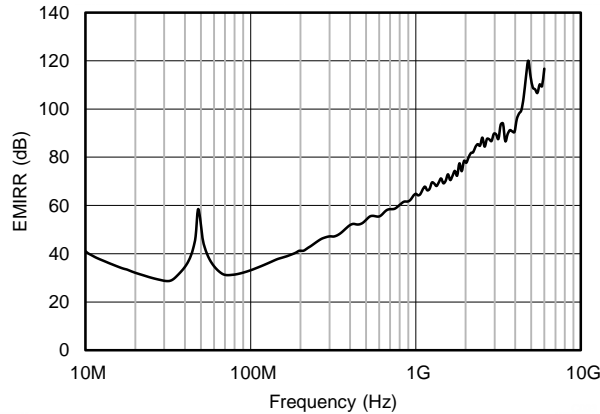

Figure 30. OPA164x EMIRR vs Frequency

[Table 1](#) lists the EMIRR IN+ values for the OPA164x at particular frequencies commonly encountered in real-world applications. Applications listed in [Table 1](#) can be centered on or operated near the particular frequency shown. This information can be of special interest to designers working with these types of applications, or working in other fields likely to encounter RF interference from broad sources, such as the industrial, scientific, and medical (ISM) radio band.

Table 1. OPA164x EMIRR IN+ for Frequencies of Interest

FREQUENCY	APPLICATION, ALLOCATION	EMIRR IN+
400 MHz	Mobile radio, mobile satellite, space operation, weather, radar, UHF	53.1 dB
900 MHz	GSM, radio communication and navigation, GPS (to 1.6 GHz), ISM, aeronautical mobile, UHF	72.2 dB
1.8 GHz	GSM, mobile personal comm. broadband, satellite, L-band	80.7 dB
2.4 GHz	802.11b/g/n, Bluetooth™, mobile personal comm., ISM, amateur radio and satellite, S-band	86.8 dB
3.6 GHz	Radiolocation, aero comm./nav., satellite, mobile, S-band	91.7 dB
5 GHz	802.11a/n, aero communication and navigation, mobile communication, space and satellite operation, C-band	96.6 dB

7.3.3.1 EMIRR IN+ Test Configuration

Figure 31 shows the circuit configuration for testing the EMIRR IN+. An RF source is connected to the operational amplifier noninverting input pin using a transmission line. The operational amplifier is configured in a unity-gain buffer topology with the output connected to a low-pass filter (LPF) and a digital multimeter (DMM). A large impedance mismatch at the operational amplifier input causes a voltage reflection; however, this effect is characterized and accounted for when determining the EMIRR IN+. The resulting dc offset voltage is sampled and measured by the multimeter. The LPF isolates the multimeter from residual RF signals that can interfere with multimeter accuracy. See *EMI Rejection Ratio of Operational Amplifiers (SBOA128)* for more details.

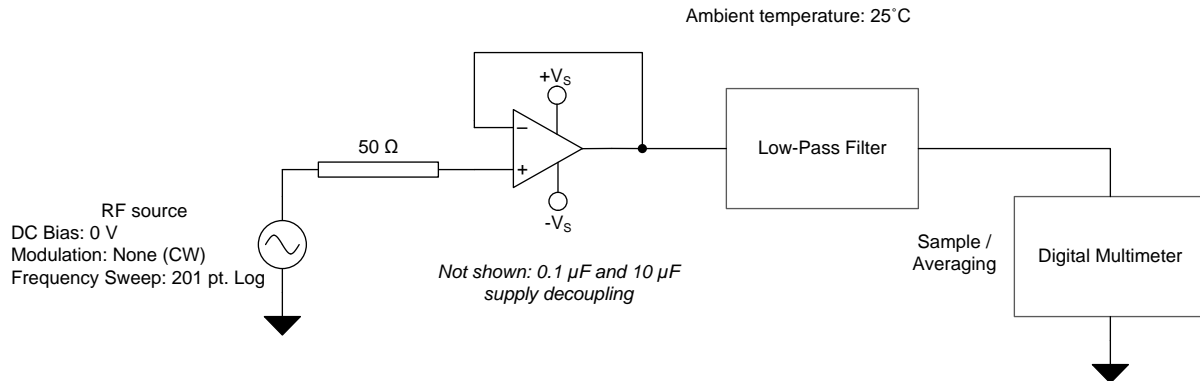

Figure 31. EMIRR IN+ Test Configuration Schematic

7.4 Device Functional Modes

7.4.1 Operating Voltage

The OPA1641, OPA1642, and OPA1644 series of operational amplifiers can be used with single or dual supplies from an operating range of $V_S = 4.5 \text{ V} (\pm 2.25 \text{ V})$ and up to $V_S = 36 \text{ V} (\pm 18 \text{ V})$. These devices do not require symmetrical supplies; only a minimum supply voltage of $4.5 \text{ V} (\pm 2.25 \text{ V})$ is required. For V_S less than $\pm 3.5 \text{ V}$, the common-mode input range does not include midsupply. Supply voltages higher than 40 V can permanently damage the device; see the *Absolute Maximum Ratings* table for more information. Key parameters are specified over the operating temperature range, $T_A = -40^\circ\text{C}$ to $+85^\circ\text{C}$. Key parameters that vary over the supply voltage or temperature range are illustrated in the *Typical Characteristics* section.

8 Application and Implementation

NOTE

Information in the following applications sections is not part of the TI component specification, and TI does not warrant its accuracy or completeness. TI's customers are responsible for determining suitability of components for their purposes. Customers should validate and test their design implementation to confirm system functionality.

8.1 Application Information

The OPA1641, OPA1642, and OPA1644 are unity-gain stable, audio operational amplifiers with very low noise, input bias current, and input offset voltage. Applications with noisy or high-impedance power supplies require decoupling capacitors placed close to the device pins. In most cases, 0.1- μ F capacitors are adequate. [Figure 32](#) shows a simplified schematic of the OPA1641.

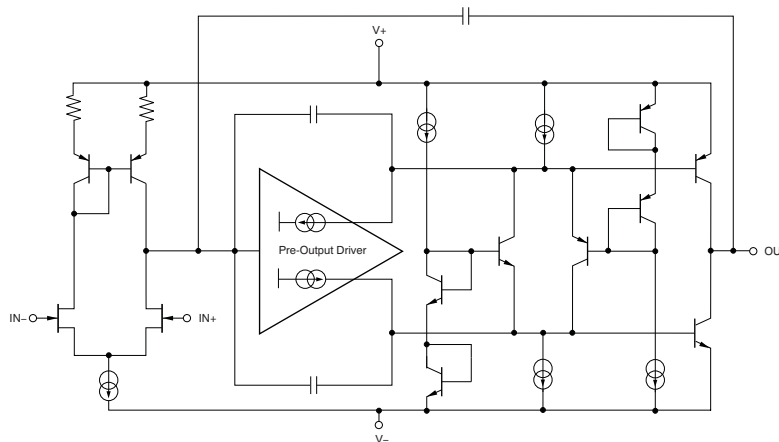

Figure 32. Simplified Internal Schematic

8.1.1 Noise Performance

[Figure 33](#) illustrates the total circuit noise for varying source impedances with the operational amplifier in a unity-gain configuration (with no feedback resistor network and therefore no additional noise contributions). The OPA1641, OPA1642, and OPA1644 are shown with total circuit noise calculated. The operational amplifier contributes both a voltage noise component and a current noise component. The voltage noise is commonly modeled as a time-varying component of the offset voltage. The current noise is modeled as the time-varying component of the input bias current and reacts with the source resistance to create a voltage component of noise. Therefore, the lowest noise operational amplifier for a given application depends on the source impedance. For low source impedance, current noise is negligible, and voltage noise generally dominates. The OPA1641, OPA1642, and OPA1644 family has both low voltage noise and extremely low current noise because of the FET input of the operational amplifier. As a result, the current noise contribution of the OPA164x series is negligible for any practical source impedance, which makes the OPA164x series of amplifiers better choices for applications with high source impedance.

The equation in [Figure 33](#) illustrates the calculation of the total circuit noise, where:

- e_n = voltage noise
- I_n = current noise
- R_S = source impedance
- k = Boltzmann's constant = 1.38×10^{-23} J/K
- T = temperature in degrees Kelvin (K)

For more details on calculating noise, see the [Basic Noise Calculations](#) section.

Application Information (continued)

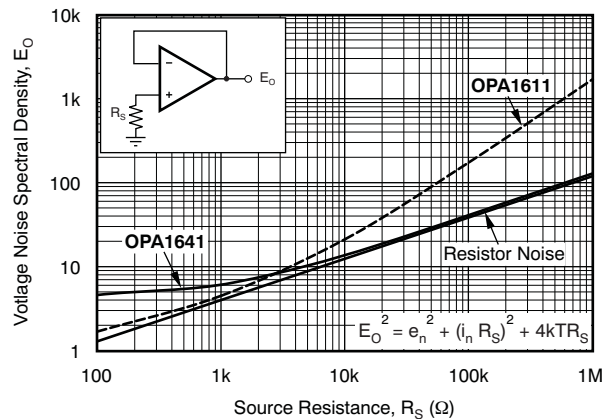

Figure 33. Noise Performance of the OPA1611 and OPA1641 in a Unity-Gain Buffer Configuration

8.1.2 Basic Noise Calculations

Low-noise circuit design requires careful analysis of all noise sources. External noise sources can dominate in many cases; consider the effect of source resistance on overall operational amplifier noise performance. Total noise of the circuit is the root-sum-square combination of all noise components.

The resistive portion of the source impedance produces thermal noise proportional to the square root of the resistance. This function is plotted in Figure 33. The source impedance is usually fixed; consequently, select the operational amplifier and the feedback resistors to minimize the respective contributions to the total noise.

Figure 34 illustrates both noninverting (A) and inverting (B) operational amplifier circuit configurations with gain. In circuit configurations with gain, the feedback network resistors also contribute noise. In general, the current noise of the operational amplifier reacts with the feedback resistors to create additional noise components. However, the extremely low current noise of the OPA164x means that the device current noise contribution can be neglected.

The feedback resistor values can generally be chosen to make these noise sources negligible. Note that low impedance feedback resistors do load the output of the amplifier. The equations for total noise are given in Figure 34 for both configurations.

A) Noise in Noninverting Gain Configuration

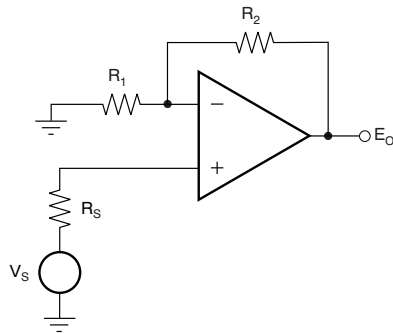

Noise at the output:

$$E_o^2 = \left(1 + \frac{R_2}{R_1}\right)^2 e_n^2 + \left(\frac{R_2}{R_1}\right)^2 e_1^2 + e_2^2 + \left(1 + \frac{R_2}{R_1}\right)^2 e_s^2$$

Where $e_s = \sqrt{4kTR_s}$ = thermal noise of R_s

$e_1 = \sqrt{4kTR_1}$ = thermal noise of R_1

$e_2 = \sqrt{4kTR_2}$ = thermal noise of R_2

B) Noise in Inverting Gain Configuration

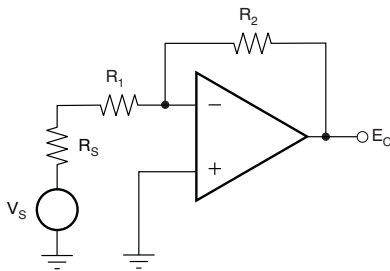

Noise at the output:

$$E_o^2 = \left(1 + \frac{R_2}{R_1 + R_s}\right)^2 e_n^2 + \left(\frac{R_2}{R_1 + R_s}\right)^2 e_1^2 + e_2^2 + \left(\frac{R_2}{R_1 + R_s}\right)^2 e_s^2$$

Where $e_s = \sqrt{4kTR_s}$ = thermal noise of R_s

$e_1 = \sqrt{4kTR_1}$ = thermal noise of R_1

$e_2 = \sqrt{4kTR_2}$ = thermal noise of R_2

For the OPA164x series op amps at 1kHz, $e_n = 5.1 \text{ nV}/\sqrt{\text{Hz}}$

Figure 34. Noise Calculation in Gain Configurations

8.1.3 Total Harmonic Distortion Measurements

The OPA164x series operational amplifiers have excellent distortion characteristics. THD + noise is below 0.00005% ($G = 1$, $V_O = 3 V_{RMS}$, $BW = 80 \text{ kHz}$) throughout the audio frequency range, 20 Hz to 20 kHz, with a 2-k Ω load (see Figure 7).

The distortion produced by the OPA164x series operational amplifiers is below the measurement limit of many commercially available distortion analyzers. However, a special test circuit (such as shown in Figure 35) can be used to extend the measurement capabilities.

Operational amplifier distortion can be considered an internal error source that can be referred to the input. Figure 35 shows a circuit that causes the operational amplifier distortion to be 101 times (or approximately 40 dB) greater than that normally produced by the operational amplifier. The addition of R_3 to the otherwise standard noninverting amplifier configuration alters the feedback factor or noise gain of the circuit. The closed-loop gain is unchanged, but the feedback available for error correction is reduced by a factor of 101, thus extending the resolution by 101. Note that the input signal and load applied to the operational amplifier are the same as with conventional feedback without R_3 . Keep the value of R_3 small to minimize any effect on distortion measurements.

The validity of this technique can be verified by duplicating measurements at high gain or high frequency where the distortion is within the measurement capability of the test equipment. Measurements for this document were made with an audio precision system two distortion and noise analyzer that greatly simplifies such repetitive measurements. The measurement technique can, however, be performed with manual distortion measurement instruments.

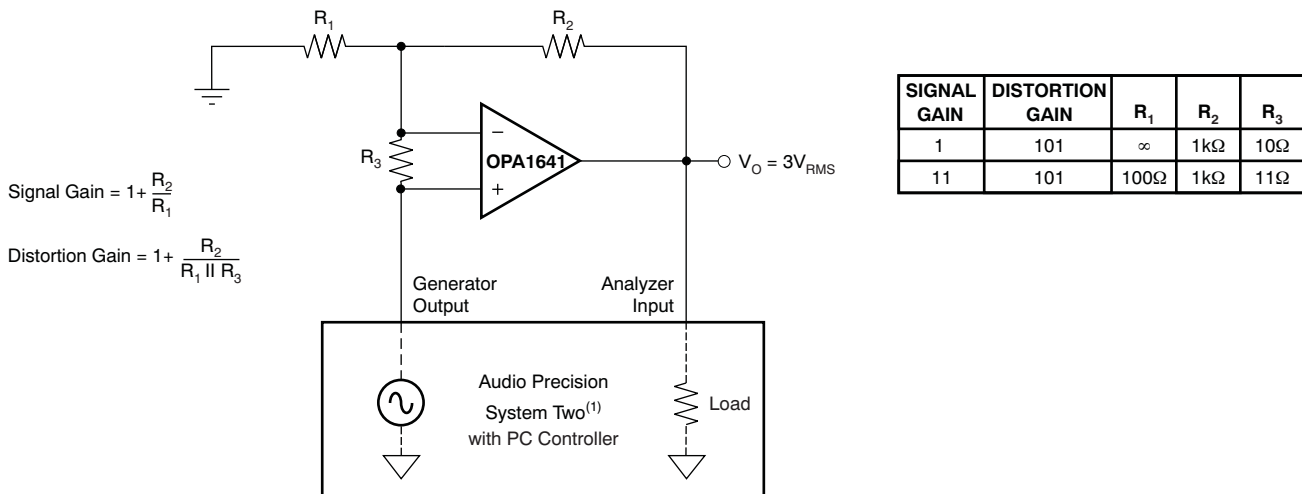

(1) For measurement bandwidth, see Figure 7 through Figure 10.

Figure 35. Distortion Test Circuit

8.1.4 Source Impedance and Distortion

In traditional JFET-input operational amplifiers, the impedance applied to the positive and negative inputs in noninverting applications must be matched for lowest distortion. Legacy methods for fabricating the JFETs in the FET input stage exhibit a varying input capacitance with applied common-mode input voltage. In inverting configurations, the input does not vary with input voltage because the inverting input is held at virtual ground. However, in noninverting applications, the inputs do vary, and the gate-to-source voltage is not constant. This effect produces increased distortion as a result of the varying capacitance for unmatched source impedances. However, the OPA164x family of amplifiers is designed to maintain a constant input capacitance with varying common-mode voltage to prevent this mechanism of distortion. The variation of input capacitance with common-mode voltage for a traditional amplifier is compared to the OPA164x family in Figure 36.

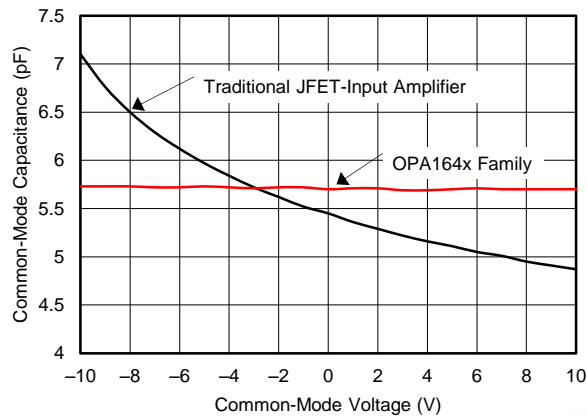

Figure 36. Input Capacitance of the OPA164x Family of Amplifiers Compared to Traditional JFET-input Amplifiers

By stabilizing the input capacitance, the distortion performance of the amplifier is greatly improved for noninverting configurations with high source impedances. The measured performance of an OPA164x amplifier is compared to a traditional JFET-input amplifier in Figure 37. The unity-gain configuration, high source impedance, and large-signal amplitude produce additional distortion in the traditional amplifier.

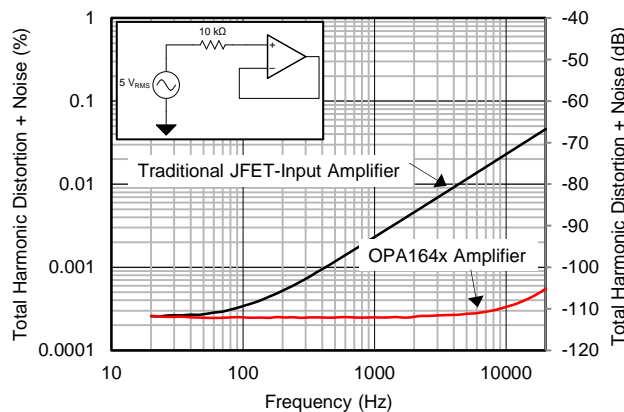

Figure 37. Measured THD+N of the OPA164x Family of Amplifiers Compared to Traditional JFET-input Amplifiers

8.1.5 Capacitive Load and Stability

The dynamic characteristics of the OPA164x are optimized for commonly encountered gains, loads, and operating conditions. The combination of low closed-loop gain and high capacitive loads decreases the phase margin of the amplifier and can lead to gain peaking or oscillations. As a result, heavier capacitive loads must be isolated from the output. The simplest way to achieve this isolation is to add a small resistor (R_{OUT} equal to 50 Ω , for example) in series with the output.

Figure 19 and Figure 20 illustrate graphs of *Small-Signal Overshoot vs Capacitive Load* for several values of R_{OUT} . Also, see Applications Bulletin AB-028, *Feedback Plots Define Op Amp AC Performance (SBOA015)* available for download at www.ti.com for details of analysis techniques and application circuits.

8.1.6 Power Dissipation and Thermal Protection

The OPA164x series of operational amplifiers are capable of driving 2-k Ω loads with power-supply voltages of up to ± 18 V over the specified temperature range. In a single-supply configuration, where the load is connected to the negative supply voltage, the minimum load resistance is 2.8 k Ω at a supply voltage of 36 V. For lower supply voltages (either single-supply or symmetrical supplies), a lower load resistance can be used, as long as the output current does not exceed 13 mA; otherwise, the device short-circuit current protection circuit can activate.

Internal power dissipation increases when operating at high supply voltages. Copper leadframe construction used in the OPA1641, OPA1642, and OPA1644 series of devices improves heat dissipation compared to conventional materials. PCB layout can also help reduce a possible increase in junction temperature. Wide copper traces help dissipate the heat by functioning as an additional heatsink. Temperature rise can be further minimized by soldering the devices directly to the PCB rather than using a socket.

Although the output current is limited by internal protection circuitry, accidental shorting one or more output channels of a device can result in excessive heating. For instance, when an output is shorted to mid-supply, the typical short-circuit current of 36 mA leads to an internal power dissipation of over 600 mW at a supply of ± 18 V. In case of a dual OPA1642 in an VSSOP-8 package (thermal resistance $\theta_{JA} = 180^\circ\text{C/W}$), such a power dissipation results in the die temperature to be 220°C above ambient temperature, when both channels are shorted. This temperature increase will destroy the device.

To prevent such excessive heating that can destroy the device, the OPA164x series has an internal thermal shutdown circuit that shuts down the device if the die temperature exceeds approximately 180°C . When this thermal shutdown circuit activates, a built-in hysteresis of 15°C ensures that the die temperature must drop to approximately 165°C before the device switches on again.

8.1.7 Electrical Overstress

Designers often ask questions about the capability of an operational amplifier to withstand electrical overstress. These questions tend to focus on the device inputs, but can involve the supply voltage pins or even the output pin. Each of these different pin functions have electrical stress limits determined by the voltage breakdown characteristics of the particular semiconductor fabrication process and specific circuits connected to the pin. Additionally, internal electrostatic discharge (ESD) protection is built into these circuits to protect them from accidental ESD events both before and during product assembly.

Having a good understanding of this basic ESD circuitry and its relevance to an electrical overstress event is helpful. [Figure 38](#) illustrates the ESD circuits contained in the OPA164x series (indicated by the dashed line area). The ESD protection circuitry involves several current-steering diodes connected from the input and output pins and routed back to the internal power-supply lines where an internal absorption device is connected. This protection circuitry is intended to remain inactive during normal circuit operation.

An ESD event produces a short duration, high-voltage pulse that is transformed into a short-duration, high-current pulse when discharging through a semiconductor device. The ESD protection circuits are designed to provide a current path around the operational amplifier core to prevent damage. The energy absorbed by the protection circuitry is then dissipated as heat.

When an ESD voltage develops across two or more of the amplifier device pins, current flows through one or more of the steering diodes. Depending on the path that the current takes, the absorption device can activate. The absorption device has a trigger, or threshold voltage, that is above the normal operating voltage of the OPA164x but below the device breakdown voltage level. When this threshold is exceeded, the absorption device quickly activates and clamps the voltage across the supply rails to a safe level.

When the operational amplifier connects into a circuit such as the one illustrated in [Figure 38](#), the ESD protection components are intended to remain inactive and not become involved in the application circuit operation. However, circumstances can arise where an applied voltage exceeds the operating voltage range of a given pin. If this condition occurs, some of the internal ESD protection circuits can be biased on and conduct current. Any such current flow occurs through steering diode paths and rarely involves the absorption device.

[Figure 38](#) depicts a specific example where the input voltage, V_{IN} , exceeds the positive supply voltage ($+V_S$) by 500 mV or more. Much of what happens in the circuit depends on the supply characteristics. If $+V_S$ can sink the current, one of the upper input steering diodes conducts and directs current to $+V_S$. Excessively high current levels can flow with increasingly higher V_{IN} . As a result, the datasheet specifications recommend that applications limit the input current to 10 mA.

If the supply is not capable of sinking the current, V_{IN} can begin sourcing current to the operational amplifier, and then take over as the source of positive supply voltage. The danger in this case is that the voltage can rise to levels that exceed the operational amplifier absolute maximum ratings.

Another common question involves what happens to the amplifier if an input signal is applied to the input when the power supplies $+V_S$ and $-V_S$ are at 0 V. The amplifier behavior depends on the supply characteristic when at 0 V, or at a level below the input signal amplitude. If the supplies appear as high impedance, then the operational amplifier supply current can be supplied by the input source through the current steering diodes. This state is not a normal bias condition; the amplifier most likely will not operate normally. If the supplies are low impedance, then the current through the steering diodes can become quite high. The current level depends on the ability of the input source to deliver current, and any resistance in the input path.

If there is an uncertainty about the ability of the supply to absorb this current, external Zener diodes can be added to the supply pins, as shown in Figure 38. The Zener voltage must be selected such that the diode does not turn on during normal operation. However, the Zener voltage must be low enough so that the Zener diode conducts if the supply pin begins to rise above the safe operating supply voltage level.

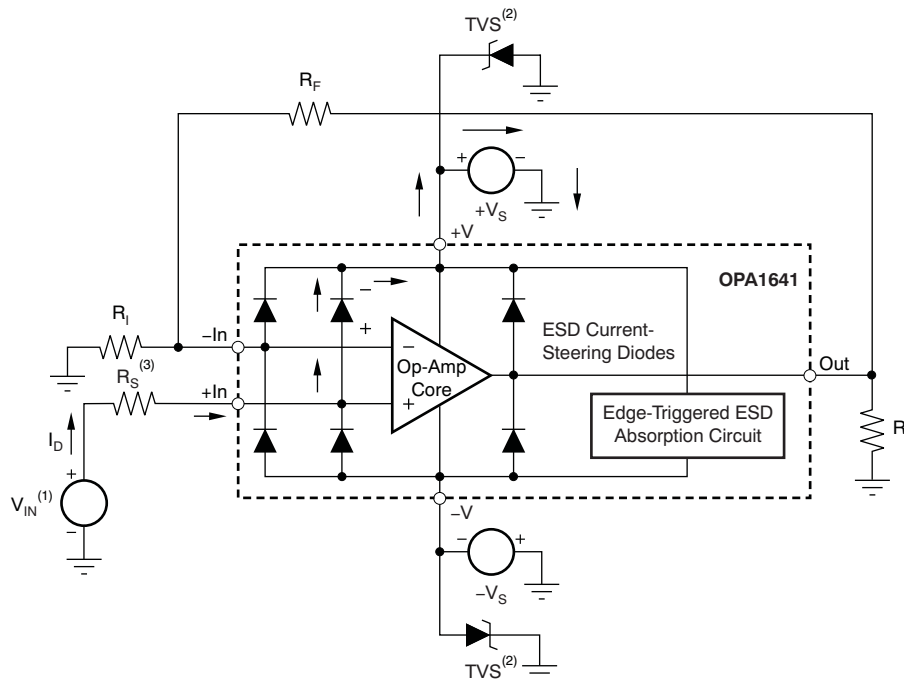

- (1) $V_{IN} = +V_S + 500 \text{ mV}$.
- (2) TVS: $+V_{S(max)} > V_{TVSBR (Min)} > +V_S$
- (3) Suggested value is approximately 1 k Ω .

Figure 38. Equivalent Internal ESD Circuitry and the Relation to a Typical Circuit Application

8.2 Typical Application

The noise and distortion performance of the OPA164x family of amplifiers is exceptional in applications with high source impedances, which makes these devices an excellent choice in preamplifier circuits for moving magnet phono cartridges. The high source impedance of the cartridge, and high gain required by the RIAA playback curve at low frequency, requires an amplifier with both low input current noise and low input voltage noise.

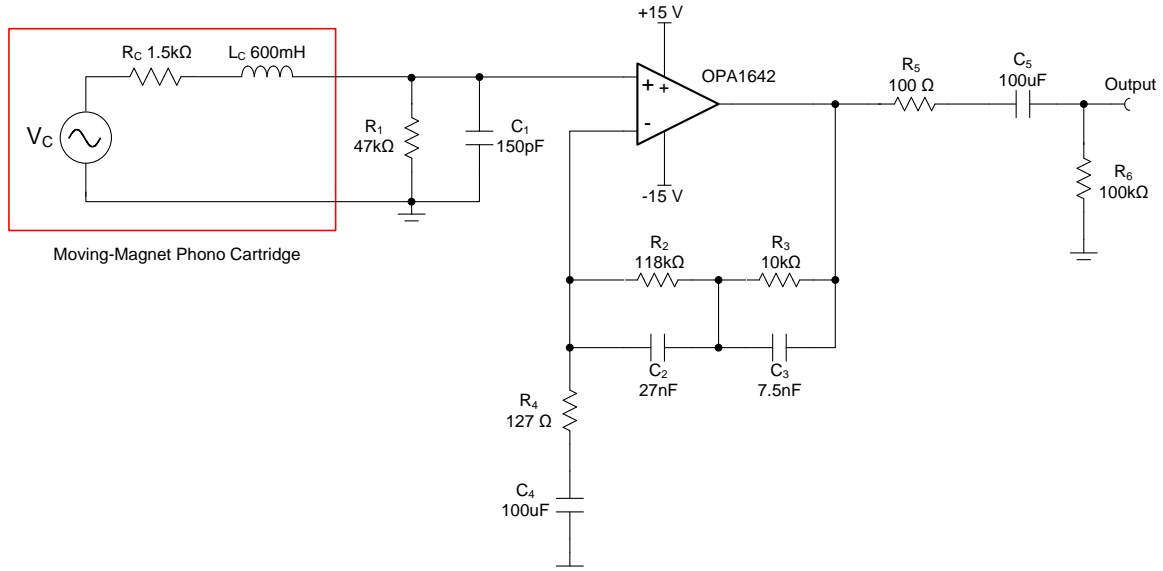

Figure 39. Preamplifier Circuit for Vinyl Record Playback With Moving-Magnet Phono Cartridges (Single Channel Shown)

8.2.1 Design Requirements

- Gain: 40 dB (1 kHz)
- RIAA Accuracy: ± 0.5 dB (100 Hz to 20 kHz)
- Power Supplies: ± 15 V

8.2.2 Detailed Design Procedure

Vinyl records are recorded using an equalization curve specified by the Recording Institute Association of America (RIAA). The purpose of this equalization curve is to decrease the amount of space occupied by a groove on the record and therefore maximize the amount of information able to be stored. Proper playback of music stored on the record requires a preamplifier circuit that applies the inverse transfer function of the recording equalization curve. The combination of the recording equalization and the playback equalization results in a flat frequency response over the audio range; see [Figure 40](#).

Typical Application (continued)

Figure 40. RIAA Recording and Playback Curves Normalized at 1 kHz

The basic RIAA playback curve implements three time constants: 75 μ s, 380 μ s, and 3180 μ s. An IEC amendment is later added to the playback curve and implements a pole in the curve at 20 Hz with the intent of protecting loudspeakers from excessive low frequency content. Rather than strictly adhering to the IEC amendment, this design moves this pole to a lower frequency to improve low frequency response and still providing protection for loudspeakers.

Resistor R1 and capacitor C1 are selected to provide the proper input impedance for the moving magnet cartridge. Cartridge loading is specified by the manufacturer in the cartridge datasheet and is absolutely crucial for proper response at high frequency. 47 k Ω is a common value for the input resistor, and the capacitive loading is usually specified to 200 pF to 300 pF per channel. This capacitive loading specification includes the capacitance of the cable connecting the turntable to the preamplifier, as well as any additional parasitic capacitances at the preamplifier input. Therefore, the value of C1 must be less than the loading specification to account for these additional capacitances.

The output network consisting of R5, R6, and C5 serves to ac couple the preamplifier circuit to any subsequent electronics in the signal path. The 100- Ω resistor R5 limits in-rush current into coupling capacitor C5 and prevents parasitic capacitance from cabling from causing instability. R6 prevents charge accumulation on C5. Capacitor C5 is chosen to be the same value as C4; for simplicity however, the value of C5 must be large enough to avoid attenuating low frequency information.

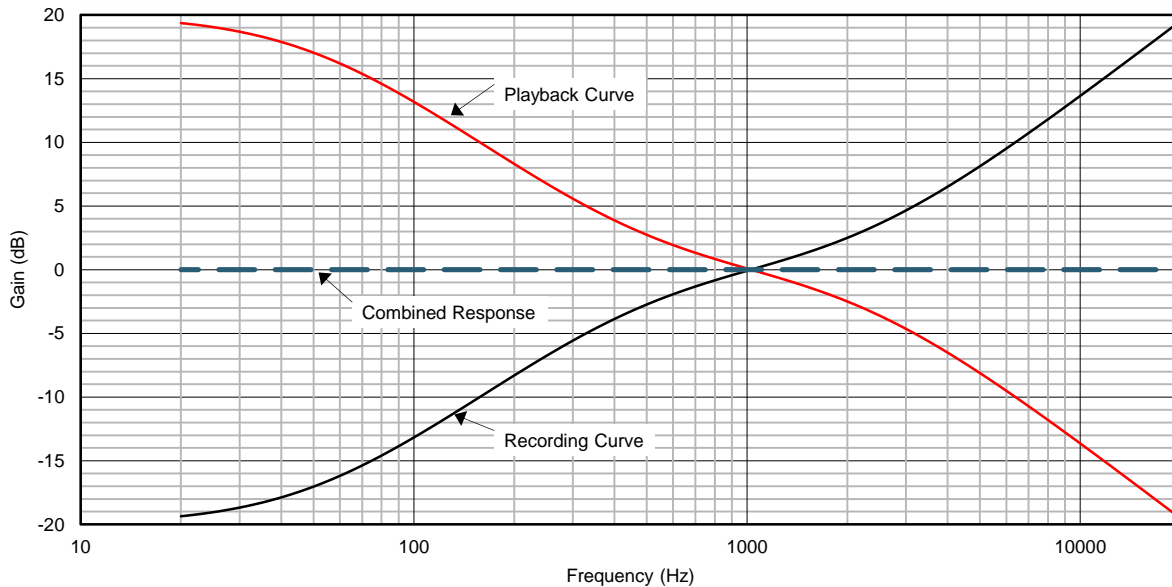
The feedback resistor elements must be selected to provide the correct response within the audio bandwidth. In order to achieve the correct frequency response, the passive components in [Figure 39](#) must satisfy [Equation 1](#), [Equation 2](#), and [Equation 3](#):

$$R_2 \times C_2 = 3180\mu\text{s} \quad (1)$$

$$R_3 \times C_3 = 75\mu\text{s} \quad (2)$$

$$(R_2 \parallel R_3) \times (C_2 + C_3) = 318\mu\text{s} \quad (3)$$

R2, R3, and R4 must also be selected to meet the design requirements for gain. The gain at 1 kHz is determined by subtracting 20 dB from gain of the circuit at very low frequency (near dc), as shown in [Equation 4](#):

$$A_{1\text{kHz}} = A_{\text{LF}} - 20\text{dB} \quad (4)$$

Typical Application (continued)

Therefore, the low frequency gain of the circuit must be 60 dB to meet the goal of 40 dB at 1 kHz and is determined by resistors R2, R3, and R4 as shown in [Equation 5](#):

$$A_{LF} = 1 + \frac{R_3 + R_2}{R_4} = 1000(60\text{dB}) \quad (5)$$

Because there are multiple combinations of passive components that satisfy these equations, a spreadsheet or other software calculation tool is the easiest method to examine resistor and capacitor combinations.

Capacitor C4 forces the gain of the circuit to unity at dc in order to limit the offset voltage at the output of the preamplifier circuit. The high-pass corner frequency created by this capacitor is calculated by [Equation 6](#):

$$F_{HP} = \frac{1}{2\pi R_4 C_4} \quad (6)$$

The circuit described in [Figure 39](#) is constructed with 1% tolerance resistors and 5% tolerance NP0, C0G ceramic capacitors without any additional hand sorting. The large value of C4 typically requires an electrolytic type to be used. However, electrolytic capacitors have the potential to introduce distortion into the signal path. This circuit is constructed using a bipolar electrolytic capacitor specifically intended for audio applications.

8.2.3 Application Curves

The deviation from the ideal RIAA transfer function curve is shown in [Figure 41](#) and normalized to an ideal gain of 40 dB at 1 kHz. The measured gain at 1 kHz is 0.05 dB less than the design goal, and the maximum deviation from 100 Hz to 20 kHz is 0.18 dB. The deviation from the ideal curve can be improved by hand-sorting resistor and capacitor values to their ideal values. The value of C4 can also be increased to reduce the deviation at low frequency.

A spectrum of the preamplifier output signal is shown in [Figure 42](#) for a 10 mV_{RMS}, 1-kHz input signal (1-V_{RMS} output). All distortion harmonics are below the preamplifier noise floor.

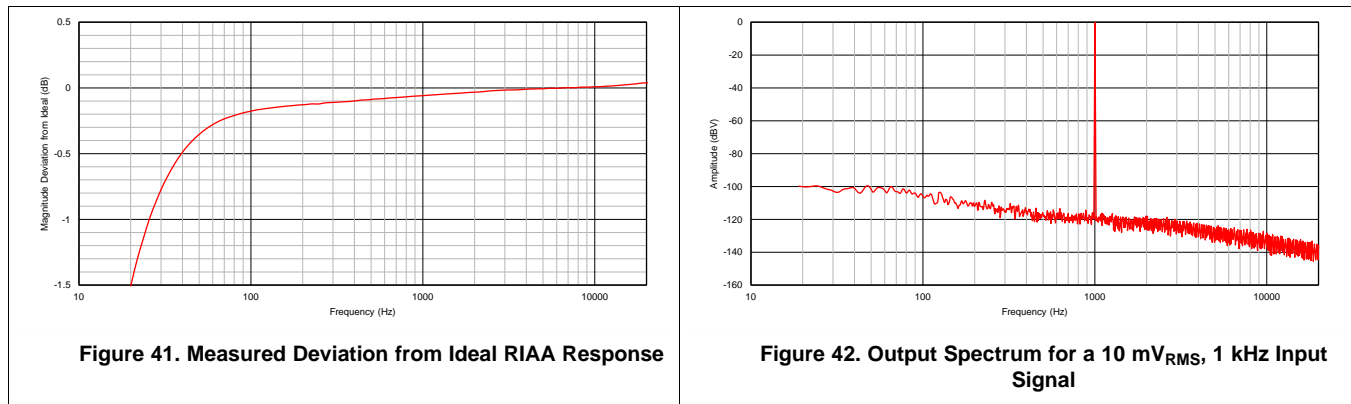

9 Power Supply Recommendations

The OPA164x are specified for operation from 4.5 V to 36 V (± 2.25 V to ± 18 V); many specifications apply from -40°C to $+125^\circ\text{C}$. Parameters that can exhibit significant variance with regard to operating voltage or temperature are presented in the [Typical Characteristics](#) section.

10 Layout

10.1 Layout Guidelines

For best operational performance of the device, use good PCB layout practices, including:

- Noise can propagate into analog circuitry through the power pins of the circuit as a whole and of op amp itself. Bypass capacitors are used to reduce the coupled noise by providing low-impedance power sources local to the analog circuitry.
 - Connect low-ESR, 0.1- μ F ceramic bypass capacitors between each supply pin and ground, placed as close to the device as possible. A single bypass capacitor from V+ to ground is applicable for single-supply applications.
- Separate grounding for analog and digital portions of circuitry is one of the simplest and most-effective methods of noise suppression. One or more layers on multilayer PCBs are usually devoted to ground planes. A ground plane helps distribute heat and reduces EMI noise pickup. Make sure to physically separate digital and analog grounds, paying attention to the flow of the ground current. For more detailed information, see *Circuit Board Layout Techniques*, [SLOA089](#).
- To reduce parasitic coupling, run the input traces as far away from the supply or output traces as possible. If these traces cannot be kept separate, crossing the sensitive trace perpendicular is much better as opposed to in parallel with the noisy trace.
- Place the external components as close to the device as possible. As illustrated in [Figure 43](#), keeping RF and RG close to the inverting input minimizes parasitic capacitance.
- Keep the length of input traces as short as possible. Always remember that the input traces are the most sensitive part of the circuit.
- Consider a driven, low-impedance guard ring around the critical traces. A guard ring can significantly reduce leakage currents from nearby traces that are at different potentials.
- Cleaning the PCB following board assembly is recommended for best performance.
- Any precision integrated circuit can experience performance shifts resulting from moisture ingress into the plastic package. Following any aqueous PCB cleaning process, baking the PCB assembly is recommended to remove moisture introduced into the device packaging during the cleaning process. A low temperature, post-cleaning bake at 85°C for 30 minutes is sufficient for most circumstances.

10.2 Layout Example

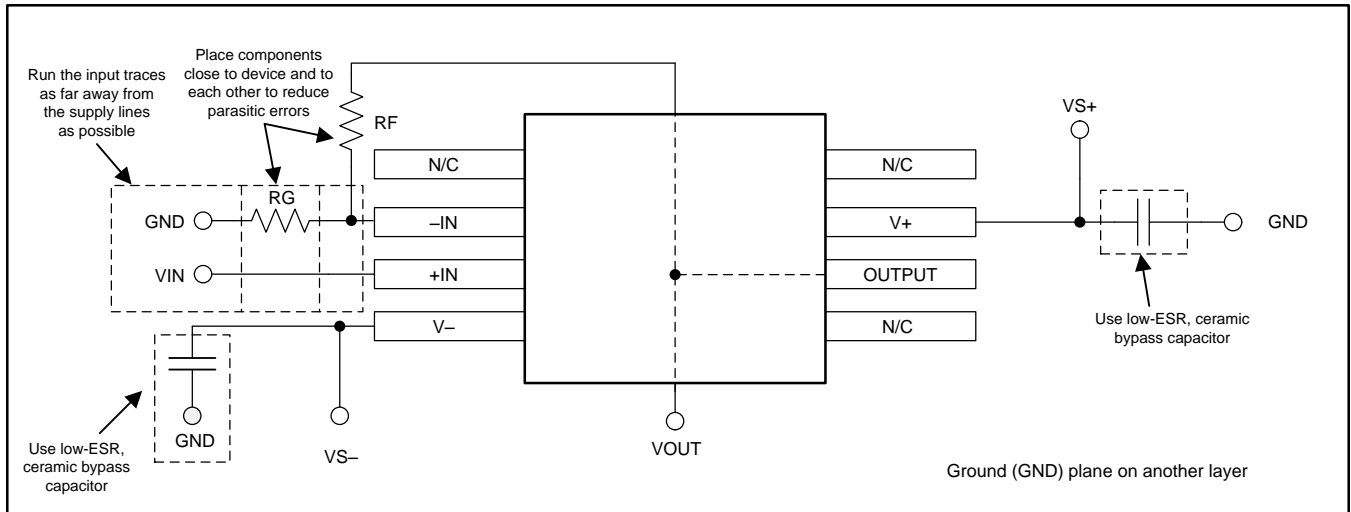
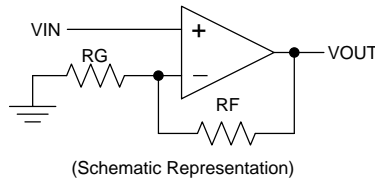

Figure 43. OPA1641 Layout Example

11 Device and Documentation Support

11.1 Device Support

11.1.1 Development Support

11.1.1.1 TINA-TI™ (Free Software Download)

TINA™ is a simple, powerful, and easy-to-use circuit simulation program based on a SPICE engine. TINA-TI is a free, fully-functional version of the TINA software, preloaded with a library of macromodels in addition to a range of both passive and active models. TINA-TI provides all the conventional dc, transient, and frequency domain analysis of SPICE, as well as additional design capabilities.

Available as a [free download](#) from the Analog eLab Design Center, TINA-TI offers extensive post-processing capability that allows users to format results in a variety of ways. Virtual instruments offer the ability to select input waveforms and probe circuit nodes, voltages, and waveforms, creating a dynamic quick-start tool.

NOTE

These files require that either the TINA software (from DesignSoft™) or TINA-TI software be installed. Download the free TINA-TI software from the [TINA-TI folder](#).

11.1.1.2 TI Precision Designs

TI Precision Designs, available online at <http://www.ti.com/ww/en/analog/precision-designs/>, are analog solutions created by TI's precision analog applications experts and offer the theory of operation, component selection, simulation, complete PCB schematic and layout, bill of materials, and measured performance of many useful circuits.

11.1.1.3 WEBENCH® Filter Designer

[WEBENCH® Filter Designer](#) is a simple, powerful, and easy-to-use active filter design program. The WEBENCH Filter Designer lets optimized filter designs to be created using a selection of TI operational amplifiers and passive components from TI's vendor partners.

Available as a web based tool from the WEBENCH® Design Center, the [WEBENCH® Filter Designer](#) allows complete multistage active filter solutions to be designed, optimized, and simulated within minutes.

11.2 Documentation Support

11.2.1 Related Documentation

For related documentation see the following:

- *Circuit Board Layout Techniques*, [SLOA089](#)
- *Op Amps for Everyone*, [SLOD006](#)
- *Operational amplifier gain stability, Part 3: AC gain-error analysis*, [SLYT383](#)
- *Operational amplifier gain stability, Part 2: DC gain-error analysis*, [SLYT374](#)
- *Using infinite-gain, MFB filter topology in fully differential active filters*, [SLYT343](#)
- *Op Amp Performance Analysis*, [SBOS054](#)
- *Single-Supply Operation of Operational Amplifiers*, [SBOA059](#)
- *Tuning in Amplifiers*, [SBOA067](#)
- *Shelf-Life Evaluation of Lead-Free Component Finishes*, [SZZA046](#)

11.3 Related Links

Table 2 lists quick access links. Categories include technical documents, support and community resources, tools and software, and quick access to sample or buy.

Table 2. Related Links

PARTS	PRODUCT FOLDER	SAMPLE & BUY	TECHNICAL DOCUMENTS	TOOLS & SOFTWARE	SUPPORT & COMMUNITY
OPA1641	Click here	Click here	Click here	Click here	Click here
OPA1642	Click here	Click here	Click here	Click here	Click here
OPA1644	Click here	Click here	Click here	Click here	Click here

11.4 Community Resources

The following links connect to TI community resources. Linked contents are provided "AS IS" by the respective contributors. They do not constitute TI specifications and do not necessarily reflect TI's views; see TI's [Terms of Use](#).

TI E2E™ Online Community *TI's Engineer-to-Engineer (E2E) Community*. Created to foster collaboration among engineers. At e2e.ti.com, you can ask questions, share knowledge, explore ideas and help solve problems with fellow engineers.

Design Support *TI's Design Support* Quickly find helpful E2E forums along with design support tools and contact information for technical support.

11.5 Trademarks

SoundPlus, E2E are trademarks of Texas Instruments.

TINA-TI is a trademark of Texas Instruments, Inc and DesignSoft, Inc.

Blu-ray is a trademark of Blu-Ray Disc Association.

TINA, DesignSoft are trademarks of DesignSoft, Inc.

All other trademarks are the property of their respective owners.

11.6 Electrostatic Discharge Caution



This integrated circuit can be damaged by ESD. Texas Instruments recommends that all integrated circuits be handled with appropriate precautions. Failure to observe proper handling and installation procedures can cause damage.

ESD damage can range from subtle performance degradation to complete device failure. Precision integrated circuits may be more susceptible to damage because very small parametric changes could cause the device not to meet its published specifications.

11.7 Glossary

[SLYZ022](#) — *TI Glossary*.

This glossary lists and explains terms, acronyms, and definitions.

12 Mechanical, Packaging, and Orderable Information

The following pages include mechanical, packaging, and orderable information. This information is the most current data available for the designated devices. This data is subject to change without notice and revision of this document. For browser-based versions of this data sheet, refer to the left-hand navigation.

PACKAGING INFORMATION

Orderable Device	Status (1)	Package Type	Package Drawing	Pins	Package Qty	Eco Plan (2)	Lead/Ball Finish (6)	MSL Peak Temp (3)	Op Temp (°C)	Device Marking (4/5)	Samples
OPA1641AID	ACTIVE	SOIC	D	8	75	Green (RoHS & no Sb/Br)	CU NIPDAU	Level-2-260C-1 YEAR	-40 to 85	O1641A	Samples
OPA1641AIDGKR	ACTIVE	VSSOP	DGK	8	2500	Green (RoHS & no Sb/Br)	CU NIPDAUAG Call TI	Level-2-260C-1 YEAR	-40 to 85	1641	Samples
OPA1641AIDGKT	ACTIVE	VSSOP	DGK	8	250	Green (RoHS & no Sb/Br)	CU NIPDAUAG Call TI	Level-2-260C-1 YEAR	-40 to 85	1641	Samples
OPA1641AIDR	ACTIVE	SOIC	D	8	2500	Green (RoHS & no Sb/Br)	CU NIPDAU	Level-2-260C-1 YEAR	-40 to 85	O1641A	Samples
OPA1642AID	ACTIVE	SOIC	D	8	75	Green (RoHS & no Sb/Br)	CU NIPDAU	Level-2-260C-1 YEAR	-40 to 85	O1642A	Samples
OPA1642AIDGKR	ACTIVE	VSSOP	DGK	8	2500	Green (RoHS & no Sb/Br)	CU NIPDAUAG	Level-2-260C-1 YEAR	-40 to 85	1642	Samples
OPA1642AIDGKT	ACTIVE	VSSOP	DGK	8	250	Green (RoHS & no Sb/Br)	CU NIPDAUAG	Level-2-260C-1 YEAR	-40 to 85	1642	Samples
OPA1642AIDR	ACTIVE	SOIC	D	8	2500	Green (RoHS & no Sb/Br)	CU NIPDAU	Level-2-260C-1 YEAR	-40 to 85	O1642A	Samples
OPA1644AID	ACTIVE	SOIC	D	14	50	Green (RoHS & no Sb/Br)	CU NIPDAU	Level-2-260C-1 YEAR	-40 to 85	O1644A	Samples
OPA1644AIDR	ACTIVE	SOIC	D	14	2500	Green (RoHS & no Sb/Br)	CU NIPDAU	Level-2-260C-1 YEAR	-40 to 85	O1644A	Samples
OPA1644AIPW	ACTIVE	TSSOP	PW	14	90	Green (RoHS & no Sb/Br)	CU NIPDAU	Level-2-260C-1 YEAR	-40 to 85	O1644A	Samples
OPA1644AIPWR	ACTIVE	TSSOP	PW	14	2000	Green (RoHS & no Sb/Br)	CU NIPDAU	Level-2-260C-1 YEAR	-40 to 85	O1644A	Samples

(1) The marketing status values are defined as follows:

ACTIVE: Product device recommended for new designs.

LIFEBUY: TI has announced that the device will be discontinued, and a lifetime-buy period is in effect.

NRND: Not recommended for new designs. Device is in production to support existing customers, but TI does not recommend using this part in a new design.

PREVIEW: Device has been announced but is not in production. Samples may or may not be available.

OBSELETE: TI has discontinued the production of the device.

(2) Eco Plan - The planned eco-friendly classification: Pb-Free (RoHS), Pb-Free (RoHS Exempt), or Green (RoHS & no Sb/Br) - please check <http://www.ti.com/productcontent> for the latest availability information and additional product content details.

TBD: The Pb-Free/Green conversion plan has not been defined.

Pb-Free (RoHS): TI's terms "Lead-Free" or "Pb-Free" mean semiconductor products that are compatible with the current RoHS requirements for all 6 substances, including the requirement that lead not exceed 0.1% by weight in homogeneous materials. Where designed to be soldered at high temperatures, TI Pb-Free products are suitable for use in specified lead-free processes.

Pb-Free (RoHS Exempt): This component has a RoHS exemption for either 1) lead-based flip-chip solder bumps used between the die and package, or 2) lead-based die adhesive used between the die and leadframe. The component is otherwise considered Pb-Free (RoHS compatible) as defined above.

Green (RoHS & no Sb/Br): TI defines "Green" to mean Pb-Free (RoHS compatible), and free of Bromine (Br) and Antimony (Sb) based flame retardants (Br or Sb do not exceed 0.1% by weight in homogeneous material)

⁽³⁾ MSL, Peak Temp. - The Moisture Sensitivity Level rating according to the JEDEC industry standard classifications, and peak solder temperature.

⁽⁴⁾ There may be additional marking, which relates to the logo, the lot trace code information, or the environmental category on the device.

⁽⁵⁾ Multiple Device Markings will be inside parentheses. Only one Device Marking contained in parentheses and separated by a "~" will appear on a device. If a line is indented then it is a continuation of the previous line and the two combined represent the entire Device Marking for that device.

⁽⁶⁾ Lead/Ball Finish - Orderable Devices may have multiple material finish options. Finish options are separated by a vertical ruled line. Lead/Ball Finish values may wrap to two lines if the finish value exceeds the maximum column width.

Important Information and Disclaimer:The information provided on this page represents TI's knowledge and belief as of the date that it is provided. TI bases its knowledge and belief on information provided by third parties, and makes no representation or warranty as to the accuracy of such information. Efforts are underway to better integrate information from third parties. TI has taken and continues to take reasonable steps to provide representative and accurate information but may not have conducted destructive testing or chemical analysis on incoming materials and chemicals. TI and TI suppliers consider certain information to be proprietary, and thus CAS numbers and other limited information may not be available for release.

In no event shall TI's liability arising out of such information exceed the total purchase price of the TI part(s) at issue in this document sold by TI to Customer on an annual basis.

TAPE AND REEL INFORMATION

QUADRANT ASSIGNMENTS FOR PIN 1 ORIENTATION IN TAPE

*All dimensions are nominal

Device	Package Type	Package Drawing	Pins	SPQ	Reel Diameter (mm)	Reel Width W1 (mm)	A0 (mm)	B0 (mm)	K0 (mm)	P1 (mm)	W (mm)	Pin1 Quadrant
OPA1641AIDGKR	VSSOP	DGK	8	2500	330.0	12.4	5.3	3.4	1.4	8.0	12.0	Q1
OPA1641AIDGKT	VSSOP	DGK	8	250	180.0	12.4	5.3	3.4	1.4	8.0	12.0	Q1
OPA1641AIDR	SOIC	D	8	2500	330.0	12.4	6.4	5.2	2.1	8.0	12.0	Q1
OPA1642AIDGKR	VSSOP	DGK	8	2500	330.0	12.4	5.3	3.4	1.4	8.0	12.0	Q1
OPA1642AIDGKT	VSSOP	DGK	8	250	180.0	12.4	5.3	3.4	1.4	8.0	12.0	Q1
OPA1642AIDR	SOIC	D	8	2500	330.0	12.4	6.4	5.2	2.1	8.0	12.0	Q1
OPA1644AIDR	SOIC	D	14	2500	330.0	16.4	6.5	9.0	2.1	8.0	16.0	Q1
OPA1644AIPWR	TSSOP	PW	14	2000	330.0	12.4	6.9	5.6	1.6	8.0	12.0	Q1

TAPE AND REEL BOX DIMENSIONS

*All dimensions are nominal

Device	Package Type	Package Drawing	Pins	SPQ	Length (mm)	Width (mm)	Height (mm)
OPA1641AIDGKR	VSSOP	DGK	8	2500	367.0	367.0	35.0
OPA1641AIDGKT	VSSOP	DGK	8	250	210.0	185.0	35.0
OPA1641AIDR	SOIC	D	8	2500	367.0	367.0	35.0
OPA1642AIDGKR	VSSOP	DGK	8	2500	367.0	367.0	35.0
OPA1642AIDGKT	VSSOP	DGK	8	250	210.0	185.0	35.0
OPA1642AIDR	SOIC	D	8	2500	367.0	367.0	35.0
OPA1644AIDR	SOIC	D	14	2500	367.0	367.0	38.0
OPA1644AIPWR	TSSOP	PW	14	2000	367.0	367.0	35.0

D (R-PDSO-G14)

PLASTIC SMALL OUTLINE

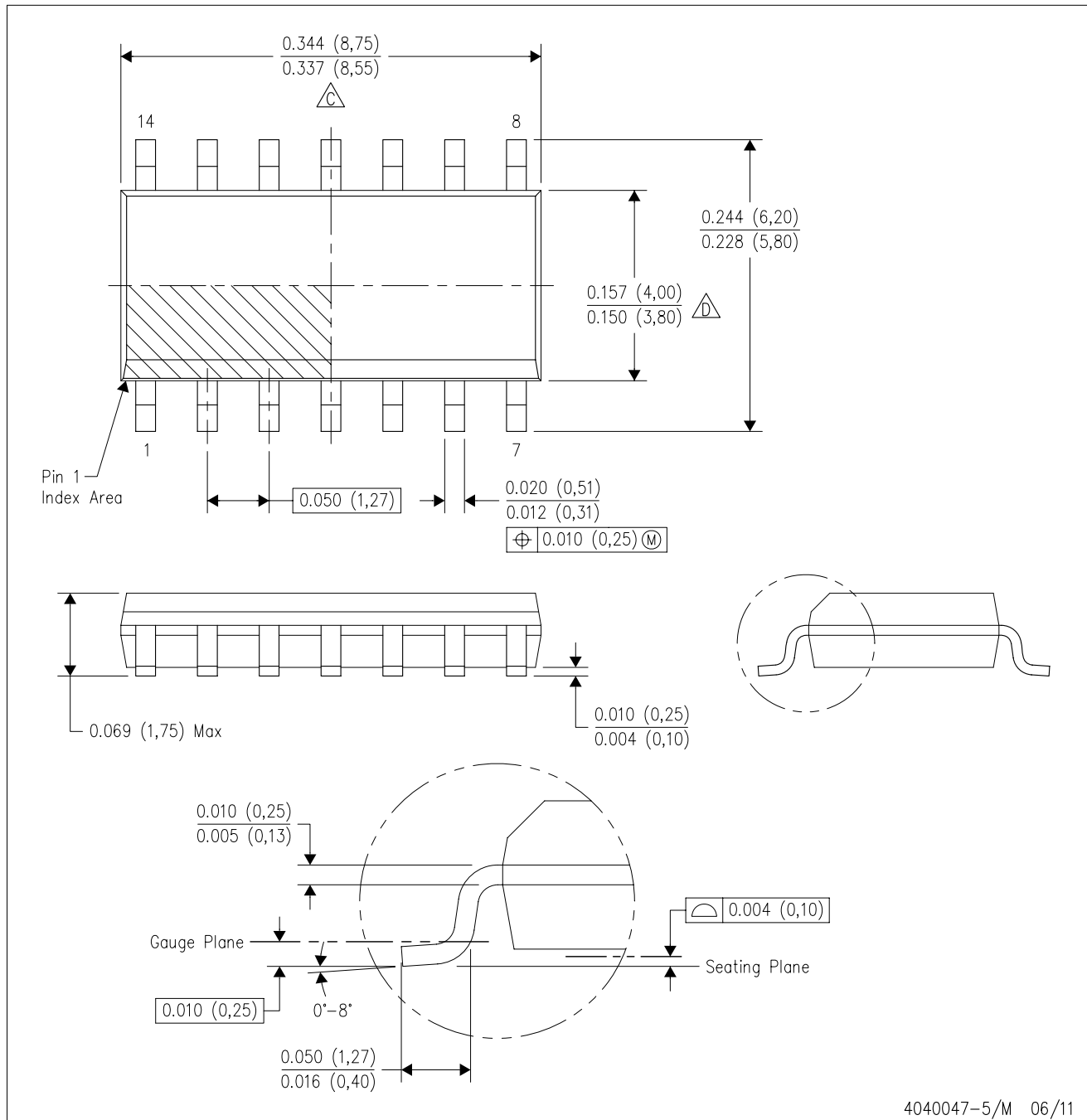

- NOTES:
- A. All linear dimensions are in inches (millimeters).
 - B. This drawing is subject to change without notice.
 - $\triangle C$ Body length does not include mold flash, protrusions, or gate burrs. Mold flash, protrusions, or gate burrs shall not exceed 0.006 (0,15) each side.
 - $\triangle D$ Body width does not include interlead flash. Interlead flash shall not exceed 0.017 (0,43) each side.
 - E. Reference JEDEC MS-012 variation AB.

D (R-PDSO-G14)

PLASTIC SMALL OUTLINE



4211283-3/E 08/12

- NOTES:
- A. All linear dimensions are in millimeters.
 - B. This drawing is subject to change without notice.
 - C. Publication IPC-7351 is recommended for alternate designs.
 - D. Laser cutting apertures with trapezoidal walls and also rounding corners will offer better paste release. Customers should contact their board assembly site for stencil design recommendations. Refer to IPC-7525 for other stencil recommendations.
 - E. Customers should contact their board fabrication site for solder mask tolerances between and around signal pads.

PW (R-PDSO-G14)

PLASTIC SMALL OUTLINE



4040064-3/G 02/11

- NOTES:
- A. All linear dimensions are in millimeters. Dimensioning and tolerancing per ASME Y14.5M-1994.
 - B. This drawing is subject to change without notice.
 - C. Body length does not include mold flash, protrusions, or gate burrs. Mold flash, protrusions, or gate burrs shall not exceed 0,15 each side.
 - D. Body width does not include interlead flash. Interlead flash shall not exceed 0,25 each side.
 - E. Falls within JEDEC MO-153

PW (R-PDSO-G14)

PLASTIC SMALL OUTLINE

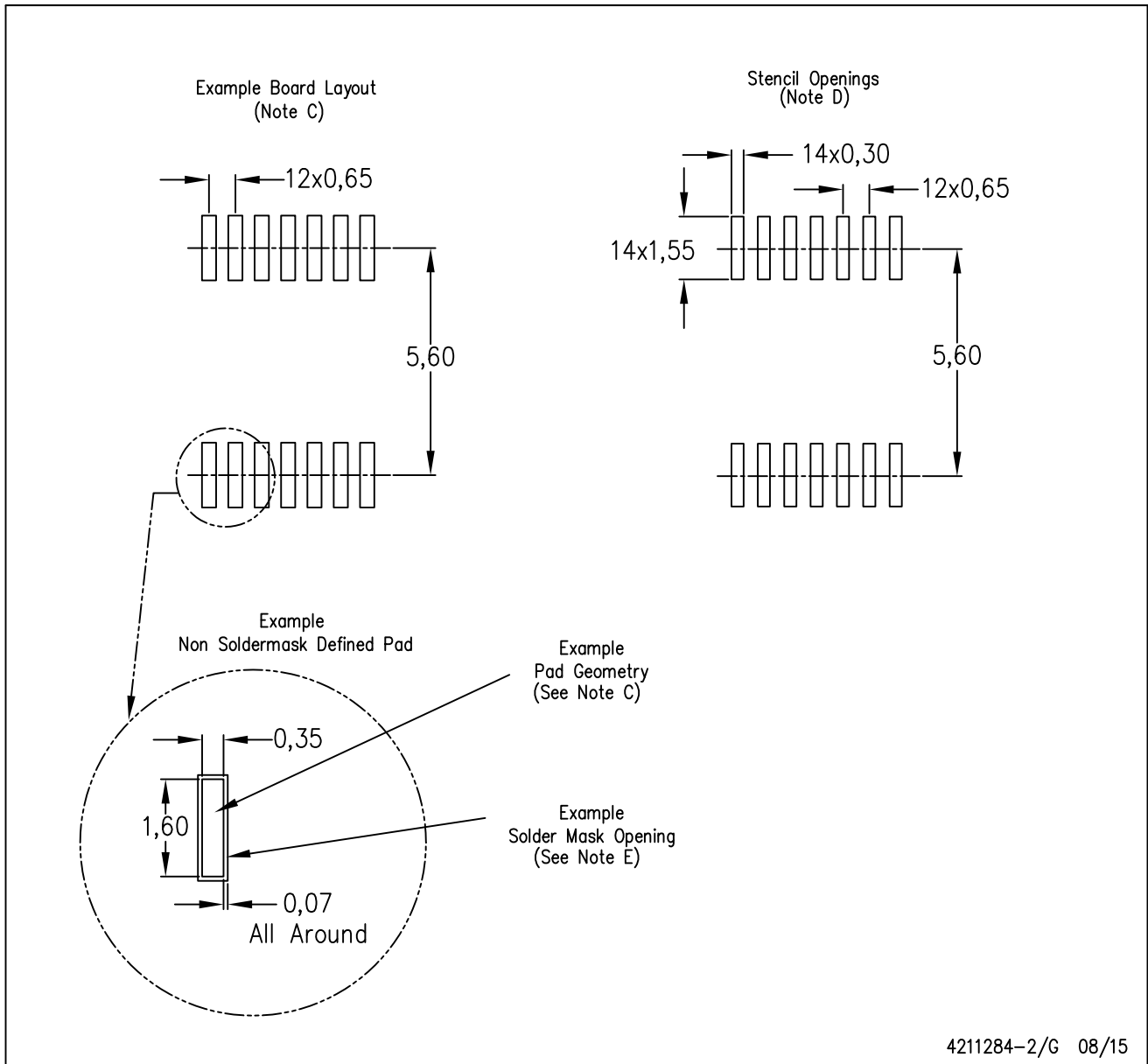

4211284-2/G 08/15

- NOTES:
- A. All linear dimensions are in millimeters.
 - B. This drawing is subject to change without notice.
 - C. Publication IPC-7351 is recommended for alternate designs.
 - D. Laser cutting apertures with trapezoidal walls and also rounding corners will offer better paste release. Customers should contact their board assembly site for stencil design recommendations. Refer to IPC-7525 for other stencil recommendations.
 - E. Customers should contact their board fabrication site for solder mask tolerances between and around signal pads.



D0008A

PACKAGE OUTLINE

SOIC - 1.75 mm max height

SMALL OUTLINE INTEGRATED CIRCUIT



NOTES:

1. Linear dimensions are in inches [millimeters]. Dimensions in parenthesis are for reference only. Controlling dimensions are in inches. Dimensioning and tolerancing per ASME Y14.5M.
2. This drawing is subject to change without notice.
3. This dimension does not include mold flash, protrusions, or gate burrs. Mold flash, protrusions, or gate burrs shall not exceed $.006$ [0.15] per side.
4. This dimension does not include interlead flash.
5. Reference JEDEC registration MS-012, variation AA.

EXAMPLE BOARD LAYOUT

D0008A

SOIC - 1.75 mm max height

SMALL OUTLINE INTEGRATED CIRCUIT

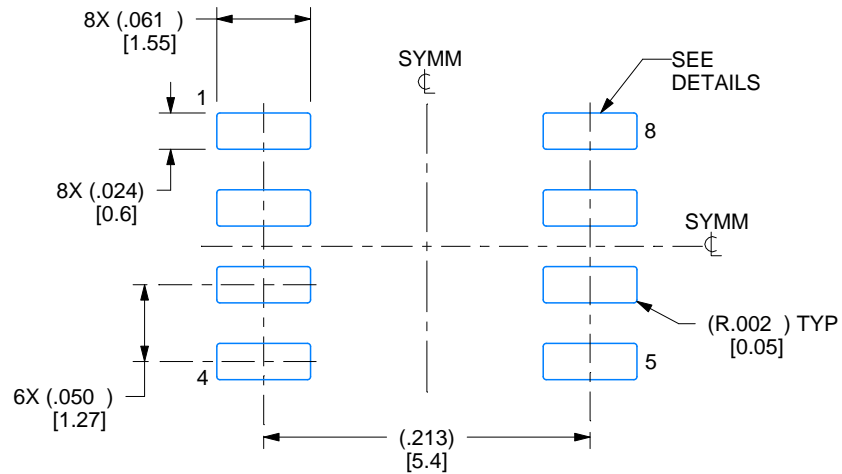

LAND PATTERN EXAMPLE
EXPOSED METAL SHOWN
SCALE:8X

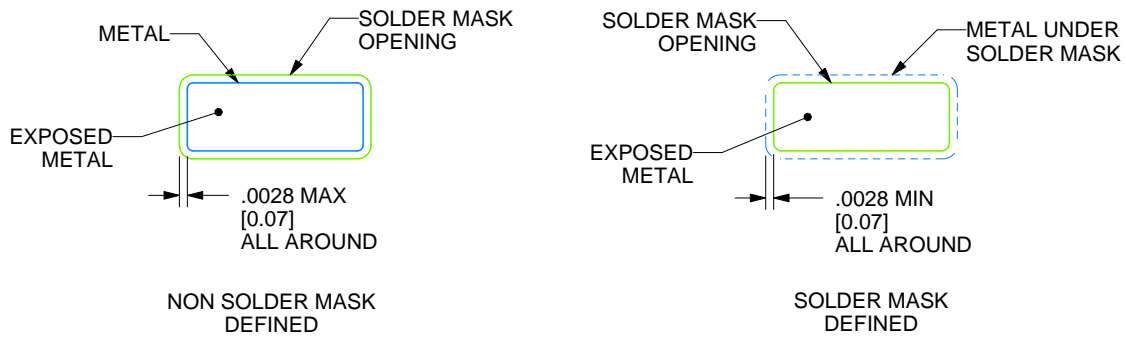

SOLDER MASK DETAILS

4214825/C 02/2019

NOTES: (continued)

6. Publication IPC-7351 may have alternate designs.

7. Solder mask tolerances between and around signal pads can vary based on board fabrication site.

EXAMPLE STENCIL DESIGN

D0008A

SOIC - 1.75 mm max height

SMALL OUTLINE INTEGRATED CIRCUIT



SOLDER PASTE EXAMPLE
BASED ON .005 INCH [0.125 MM] THICK STENCIL
SCALE:8X

4214825/C 02/2019

NOTES: (continued)

8. Laser cutting apertures with trapezoidal walls and rounded corners may offer better paste release. IPC-7525 may have alternate design recommendations.
9. Board assembly site may have different recommendations for stencil design.

DGK (S-PDSO-G8)

PLASTIC SMALL-OUTLINE PACKAGE

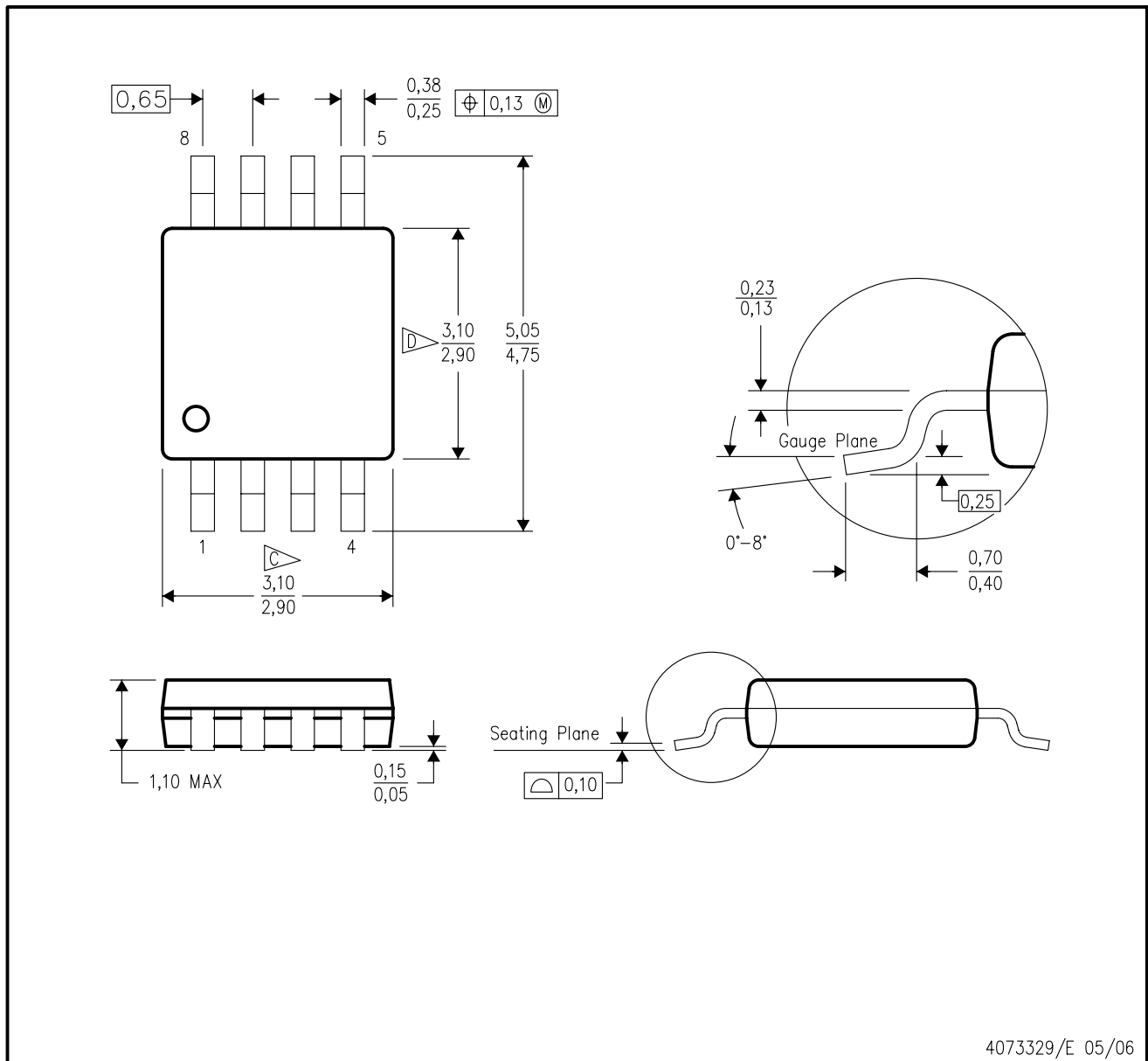

- NOTES:
- A. All linear dimensions are in millimeters.
 - B. This drawing is subject to change without notice.
 - C. Body length does not include mold flash, protrusions, or gate burrs. Mold flash, protrusions, or gate burrs shall not exceed 0.15 per end.
 - D. Body width does not include interlead flash. Interlead flash shall not exceed 0.50 per side.
 - E. Falls within JEDEC MO-187 variation AA, except interlead flash.

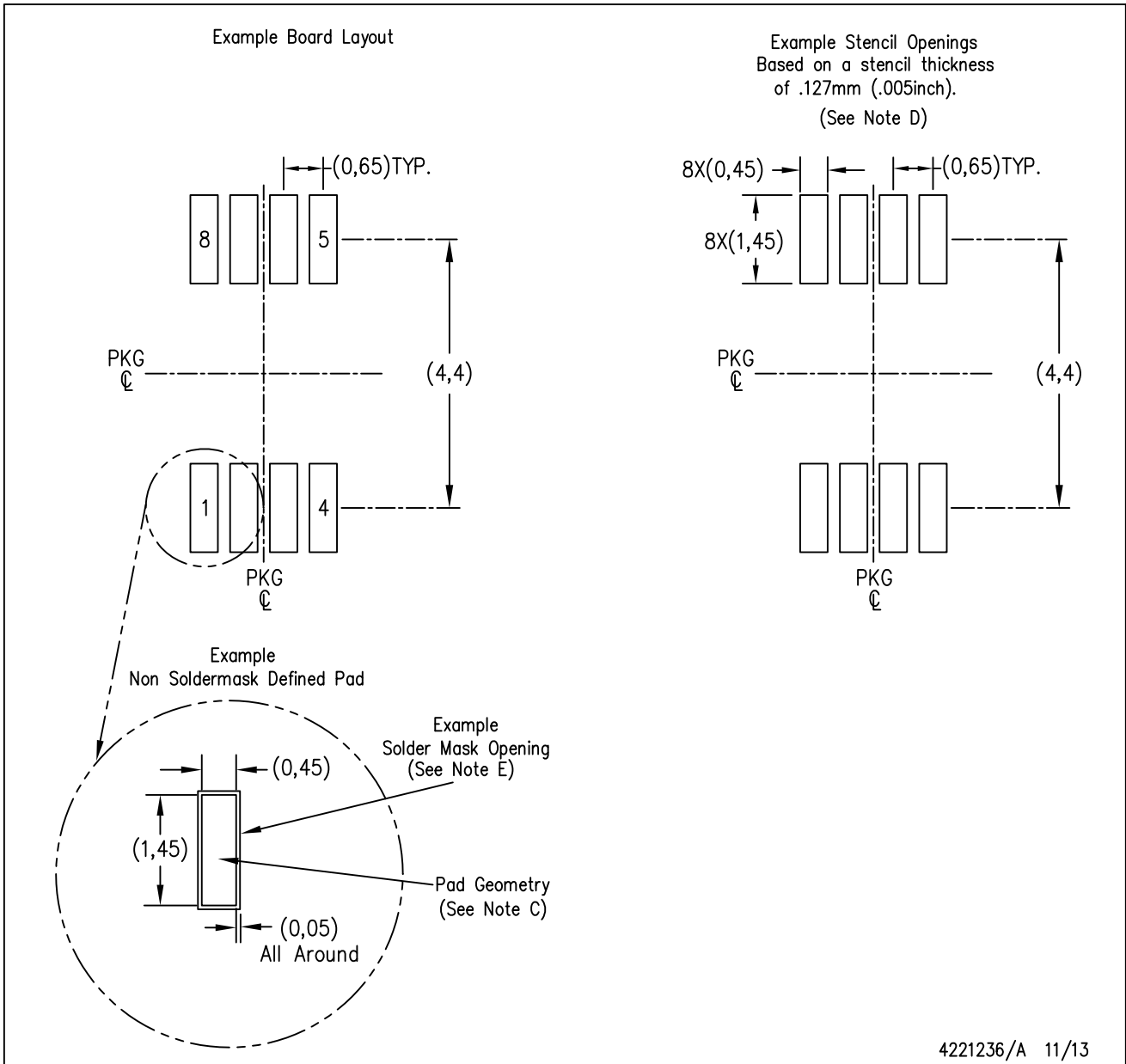

- NOTES:
- A. All linear dimensions are in millimeters.
 - B. This drawing is subject to change without notice.
 - C. Publication IPC-7351 is recommended for alternate designs.
 - D. Laser cutting apertures with trapezoidal walls and also rounding corners will offer better paste release. Customers should contact their board assembly site for stencil design recommendations. Refer to IPC-7525 for other stencil recommendations.
 - E. Customers should contact their board fabrication site for solder mask tolerances between and around signal pads.

IMPORTANT NOTICE AND DISCLAIMER

TI PROVIDES TECHNICAL AND RELIABILITY DATA (INCLUDING DATASHEETS), DESIGN RESOURCES (INCLUDING REFERENCE DESIGNS), APPLICATION OR OTHER DESIGN ADVICE, WEB TOOLS, SAFETY INFORMATION, AND OTHER RESOURCES "AS IS" AND WITH ALL FAULTS, AND DISCLAIMS ALL WARRANTIES, EXPRESS AND IMPLIED, INCLUDING WITHOUT LIMITATION ANY IMPLIED WARRANTIES OF MERCHANTABILITY, FITNESS FOR A PARTICULAR PURPOSE OR NON-INFRINGEMENT OF THIRD PARTY INTELLECTUAL PROPERTY RIGHTS.

These resources are intended for skilled developers designing with TI products. You are solely responsible for (1) selecting the appropriate TI products for your application, (2) designing, validating and testing your application, and (3) ensuring your application meets applicable standards, and any other safety, security, or other requirements. These resources are subject to change without notice. TI grants you permission to use these resources only for development of an application that uses the TI products described in the resource. Other reproduction and display of these resources is prohibited. No license is granted to any other TI intellectual property right or to any third party intellectual property right. TI disclaims responsibility for, and you will fully indemnify TI and its representatives against, any claims, damages, costs, losses, and liabilities arising out of your use of these resources.

TI's products are provided subject to TI's Terms of Sale (www.ti.com/legal/termsofsale.html) or other applicable terms available either on ti.com or provided in conjunction with such TI products. TI's provision of these resources does not expand or otherwise alter TI's applicable warranties or warranty disclaimers for TI products.

Mailing Address: Texas Instruments, Post Office Box 655303, Dallas, Texas 75265
Copyright © 2019, Texas Instruments Incorporated

Looking for pricing, stock, or lifecycle information?

Click below to explore more details on WIN SOURCE:

 [View OPA1641AID](#) on WIN SOURCE

 [Texas Instruments](#) Information

Optimize Your Supply Chain with WIN SOURCE Solutions

-  Global Sourcing Solution
-  Obsolete Management
-  Cost Control Management
-  Shortage Management
-  Alternative Solution
-  Excess Inventory Management