



**THE DATASHEET OF
MM74C74M**



MM74C74 Dual D-Type Flip-Flop

General Description

The MM74C74 dual D-type flip-flop is a monolithic complementary MOS (CMOS) integrated circuit constructed with N- and P-channel enhancement transistors. Each flip-flop has independent data, preset, clear and clock inputs and Q and \bar{Q} outputs. The logic level present at the data input is transferred to the output during the positive going transition of the clock pulse. Preset or clear is independent of the clock and accomplished by a low level at the preset or clear input.

Features

- Supply voltage range: 3V to 15V
- Tenth power TTL compatible: Drive 2 LPT²L loads
- High noise immunity: 0.45 V_{CC} (typ.)
- Low power: 50 nW (typ.)
- Medium speed operation: 10 MHz (typ.) with 10V supply

Applications

- Automotive
- Data terminals
- Instrumentation
- Medical electronics
- Alarm system
- Industrial electronics
- Remote metering
- Computers

Ordering Code:

Order Number	Package Number	Package Description
MM74C74M	M14A	14-Lead Small Outline Integrated Circuit (SOIC), JEDEC MS-012, 0.150" Narrow
MM74C74N	N14A	14-Lead Plastic Dual-In-Line Package (PDIP), JEDEC MS-001, 0.300" Wide

Devices also available in Tape and Reel. Specify by appending the suffix letter "X" to the ordering code.

Connection Diagram

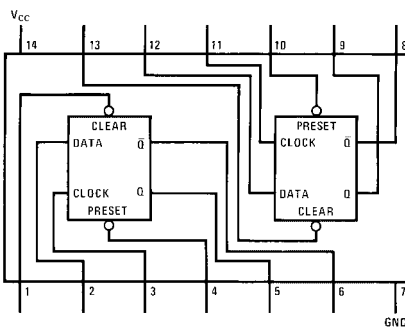

Note: A logic "0" on clear sets Q to logic "0".
A logic "0" on preset sets Q to logic "1".

Top View

Truth Table

Preset	Clear	Q _n	\bar{Q}_n
0	0	0	0
0	1	1	0
1	0	0	1
1	1	Q _n (Note 1)	\bar{Q}_n (Note 1)

Note 1: No change in output from previous state.

Absolute Maximum Ratings^(Note 2)

Voltage at Any Pin (Note 2)	-0.3V to $V_{CC} + 0.3V$
Operating Temperature Range	-55°C to +125°C
Storage Temperature Range	-65°C to +150°C
Power Dissipation	
Dual-In-Line	700 mW
Small Outline	500 mW
Lead Temperature	
(Soldering, 10 seconds)	260°C
Operating V_{CC} Range	3V to 15V
V_{CC} (Max)	18V

Note 2: "Absolute Maximum Ratings" are those values beyond which the safety of the device cannot be guaranteed. Except for "Operating Temperature Range" they are not meant to imply that the devices should be operated at these limits. The table of "Electrical Characteristics" provides conditions for actual device operation.

DC Electrical Characteristics

Min/Max limits apply across temperature range unless otherwise noted

Symbol	Parameter	Conditions	Min	Typ	Max	Units
CMOS TO CMOS						
$V_{IN(1)}$	Logical "1" Input Voltage	$V_{CC} = 5V$	3.5			V
		$V_{CC} = 10V$	80			
$V_{IN(0)}$	Logical "0" Input Voltage	$V_{CC} = 5V$			1.5	V
		$V_{CC} = 10V$			2.0	
$V_{OUT(1)}$	Logical "1" Output Voltage	$V_{CC} = 5V$	4.5			V
		$V_{CC} = 10V$	9.0			
$V_{OUT(0)}$	Logical "0" Output Voltage	$V_{CC} = 5V$			0.5	V
		$V_{CC} = 10V$			1.0	
$I_{IN(1)}$	Logical "1" Input Current	$V_{CC} = 15V$			1.0	μA
$I_{IN(0)}$	Logical "0" Input Current	$V_{CC} = 15V$	-1.0			μA
I_{CC}	Supply Current	$V_{CC} = 15V$		0.05	60	μA
CMOS/LPTTL INTERFACE						
$V_{IN(1)}$	Logical "1" Input Voltage	$V_{CC} = 4.75V$	$V_{CC} - 1.5$			
$V_{IN(0)}$	Logical "0" Input Voltage	$V_{CC} = 4.75V$			0.8	V
$V_{OUT(1)}$	Logical "1" Output Voltage	$V_{CC} = 4.75V, I_D = -360 \mu A$	2.4			V
$V_{OUT(0)}$	Logical "0" Output Voltage	$V_{CC} = 4.75V, I_D = 360 \mu A$			0.4	V
OUTPUT DRIVE (See Family Characteristics Data Sheet)						
I_{SOURCE}	Output Source Current	$V_{CC} = 5V, V_{IN(0)} = 0V$ $T_A = 25^\circ C, V_{OUT} = 0V$	-1.75			mA
I_{SOURCE}	Output Source Current	$V_{CC} = 10V, V_{IN(0)} = 0V$ $T_A = 25^\circ C, V_{OUT} = 0V$	-8.0			mA
I_{SINK}	Output Sink Current	$V_{CC} = 5V, V_{IN(1)} = 5V$ $T_A = 25^\circ C, V_{OUT} = V_{CC}$	1.75			mA
I_{SINK}	Output Sink Current	$V_{CC} = 10V, V_{IN(1)} = 10V$ $T_A = 25^\circ C, V_{OUT} = V_{CC}$	8.0			mA

AC Electrical Characteristics (Note 3)

$T_A = 25^\circ\text{C}$, $C_L = 50\text{ pF}$, unless otherwise noted

Symbol	Parameter	Conditions	Min	Typ	Max	Units
C_{IN}	Input Capacitance	Any Input (Note 4)		5.0		pF
t_{pd}	Propagation Delay Time to a Logical "0" t_{pd0} or Logical "1" t_{pd1} from Clock to Q or \bar{Q}	$V_{CC} = 5\text{V}$ $V_{CC} = 10\text{V}$		180 70	300 110	ns
t_{pd}	Propagation Delay Time to a Logical "0" from Preset or Clear	$V_{CC} = 5\text{V}$ $V_{CC} = 10\text{V}$		180 70	300 110	ns
t_{pd}	Propagation Delay Time to a Logical "1" from Preset or Clear	$V_{CC} = 5\text{V}$ $V_{CC} = 10\text{V}$		250 100	400 150	ns
t_{S0}, t_{S1}	Time Prior to Clock Pulse that Data Must be Present t_{SETUP}	$V_{CC} = 5\text{V}$ $V_{CC} = 10\text{V}$	100 40	50 20		ns
t_{H0}, t_{H1}	Time after Clock Pulse that Data Must be Held	$V_{CC} = 5\text{V}$ $V_{CC} = 10\text{V}$		-20 -8.0	0 0	ns
t_{PW1}	Minimum Clock Pulse Width ($t_{WL} = t_{WH}$)	$V_{CC} = 5\text{V}$ $V_{CC} = 10\text{V}$		100 40	250 100	ns
t_{PW2}	Minimum Preset and Clear Pulse Width	$V_{CC} = 5\text{V}$ $V_{CC} = 10\text{V}$		100 40	160 70	ns
t_r, t_f	Maximum Clock Rise and Fall Time	$V_{CC} = 5\text{V}$ $V_{CC} = 10\text{V}$	15.0 5.0			μs
f_{MAX}	Maximum Clock Frequency	$V_{CC} = 5\text{V}$ $V_{CC} = 10\text{V}$	2.0 5.0	3.5 8.0		MHz
C_{PD}	Power Dissipation Capacitance (Note 5)			40		pF

Note 3: AC Parameters are guaranteed by DC correlated testing.

Note 4: Capacitance is guaranteed by periodic testing.

Note 5: C_{PD} determines the no load AC power consumption of any CMOS device. For complete explanation see Family Characteristics Application Note—AN-90.

Typical Applications

Ripple Counter (Divide by 2^N)

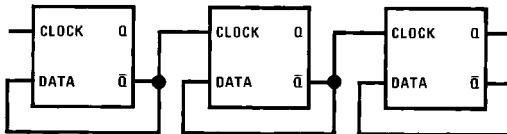

Shift Register

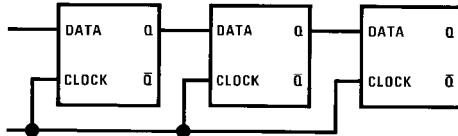

74C Compatibility

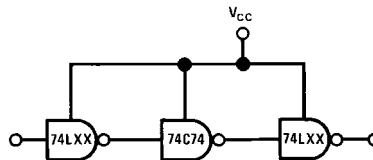

Guaranteed Noise Margin as a Function of V_{CC}

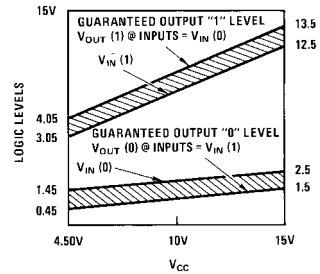

Switching Time Waveform

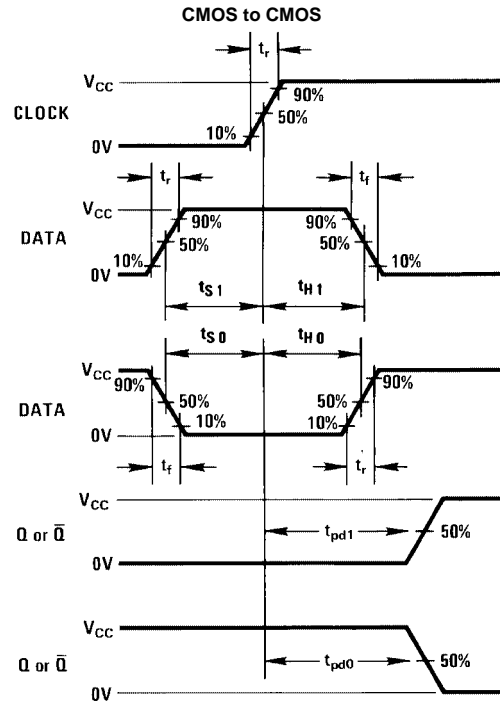

$t_r = t_f = 20 \text{ ns}$

AC Test Circuit

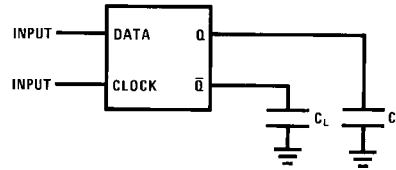

Physical Dimensions inches (millimeters) unless otherwise noted

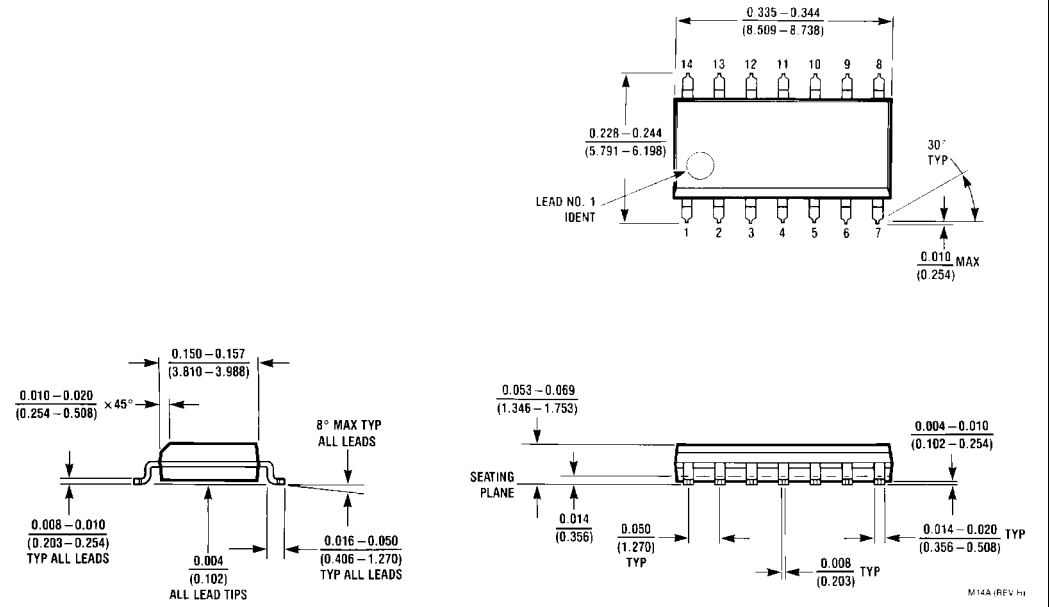

14-Lead Small Outline Integrated Circuit (SOIC), JEDEC MS-012, 0.150" Narrow Package Number M14A

Physical Dimensions inches (millimeters) unless otherwise noted (Continued)

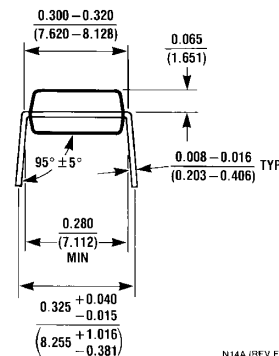
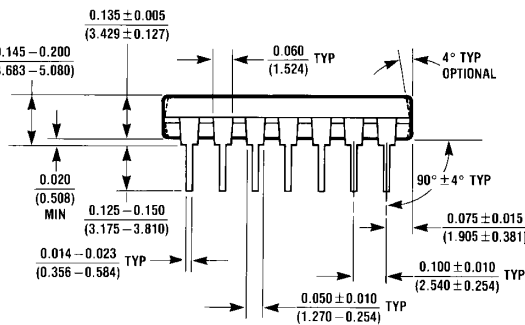
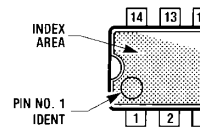
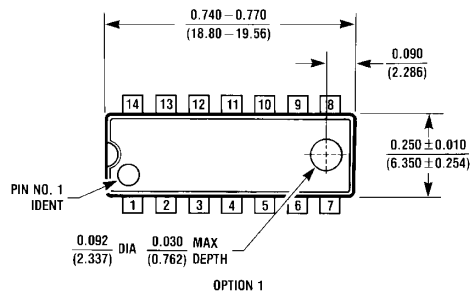

N14A (REV F)

14-Lead Plastic Dual-In-Line Package (PDIP), JEDEC MS-001, 0.300" Wide Package Number N14A

Fairchild does not assume any responsibility for use of any circuitry described, no circuit patent licenses are implied and Fairchild reserves the right at any time without notice to change said circuitry and specifications.

LIFE SUPPORT POLICY

FAIRCHILD'S PRODUCTS ARE NOT AUTHORIZED FOR USE AS CRITICAL COMPONENTS IN LIFE SUPPORT DEVICES OR SYSTEMS WITHOUT THE EXPRESS WRITTEN APPROVAL OF THE PRESIDENT OF FAIRCHILD SEMICONDUCTOR CORPORATION. As used herein:

1. Life support devices or systems are devices or systems which, (a) are intended for surgical implant into the body, or (b) support or sustain life, and (c) whose failure to perform when properly used in accordance with instructions for use provided in the labeling, can be reasonably expected to result in a significant injury to the user.
2. A critical component in any component of a life support device or system whose failure to perform can be reasonably expected to cause the failure of the life support device or system, or to affect its safety or effectiveness.

www.fairchildsemi.com

Looking for pricing, stock, or lifecycle information?

Click below to explore more details on WIN SOURCE:

-  [View MM74C74M on WIN SOURCE](#)
-  [Fairchild/ON Semiconductor Information](#)

Optimize Your Supply Chain with WIN SOURCE Solutions

-  Global Sourcing Solution
-  Obsolete Management
-  Cost Control Management
-  Shortage Management
-  Alternative Solution
-  Excess Inventory Management