



# THE DATASHEET OF ECLAMP2357N.TCT



### PROTECTION PRODUCTS - EMIClamp™

#### Description

The EClamp™2357N is a low pass filter array with integrated TVS diodes. It is designed to suppress unwanted EMI/RFI signals and provide electrostatic discharge (ESD) protection in portable electronic equipment. They have been optimized for **protection of touch screen displays, secure digital (SD) card interfaces, and color LCD panels** in cellular phones and other portable electronics.

The device consists of six pi filter circuits comprised of TVS diodes for ESD protection, and a resistor capacitor network for EMI/RFI filtering. A series resistor value of 100Ω and a component capacitance value of 10pF are used to achieve 20dB minimum attenuation from 1.0GHz to 3GHz. The device also includes 4 discrete TVS diodes for dedicated ESD protection. All of the TVS diodes provide effective suppression of ESD voltages in excess of ±15kV (air discharge) and ±8kV (contact discharge) per IEC 61000-4-2, level 4.

#### Features

- ◆ EMI/RFI filter with integrated ESD protection
- ◆ ESD protection to **IEC 61000-4-2 (ESD) Level4, ±15kV (air), ±8kV (contact)**
- ◆ Filter performance: **>30dB attenuation** at 1.8GHz
- ◆ TVS working voltage: 5V
- ◆ Resistor: 100Ω +/- 15%
- ◆ Component Capacitance: 10pF (VR = 0V)
- ◆ EMI & ESD protection for six lines
- ◆ Dedicated ESD protection for four lines
- ◆ Solid-state technology

#### Mechanical Characteristics

- ◆ 16 pin QFN
- ◆ RoHS/WEEE Compliant
- ◆ Nominal Dimensions: 3.0 x 3.0 x 1.0 mm
- ◆ Lead Pitch: 0.5mm
- ◆ Lead Finish: Matte Tin
- ◆ Marking: Marking Code
- ◆ Packaging: Tape and Reel per EIA 481

#### Applications

- ◆ Touch Screen Display Interfaces
- ◆ Secure Digital (SD) Memory Card Interfaces
- ◆ Multimedia Card Interfaces (MCI)
- ◆ Color LCD Panel Protection
- ◆ Cell Phone Handsets and Accessories

#### PIN Configuration

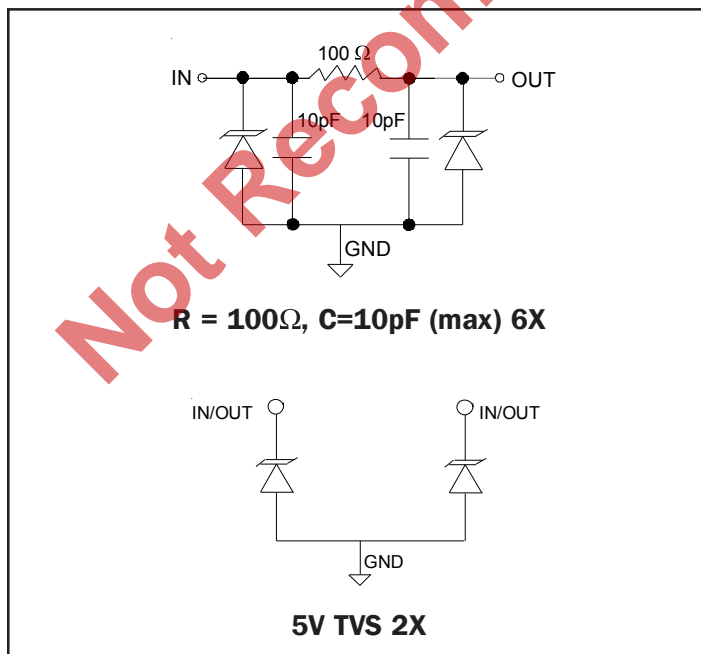

#### Package Configuration

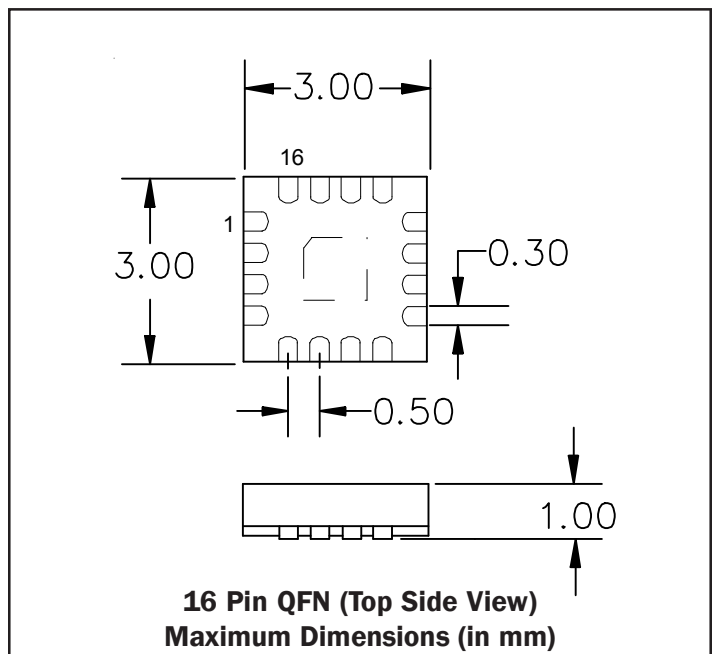

## PROTECTION PRODUCTS

### Maximum Ratings

Rating	Symbol	Value	Units
ESD per IEC 61000-4-2 (Air) ESD per IEC 61000-4-2 (Contact)	$V_{ESD}$	+/- 20 +/- 12	kV
Junction Temperature	$T_J$	125	°C
Operating Temperature	$T_{op}$	-40 to +85	°C
Storage Temperature	$T_{STG}$	-55 to +150	°C

### Electrical Characteristics

Parameter	Symbol	Conditions	Minimum	Typical	Maximum	Units
TVS Reverse Stand-Off Voltage	$V_{RWM}$				5	V
TVS Reverse Breakdown Voltage	$V_{BR}$	$I_t = 1mA$	6	8	10	V
TVS Reverse Leakage Current	$I_R$	$V_{RWM} = 3.3V$			0.5	μA
Total Series Resistance	R	Each Line	85	100	115	Ohms
Total Capacitance	$C_{in}$	Input to Gnd, Each Line $V_R = 0V, f = 1MHz$		20	22	pF
Total Capacitance	$C_{in}$	Input to Gnd, Each Line $V_R = 2.5V, f = 1MHz$		12	15	pF

### Typical Insertion Loss S21 (Each Filter)

CH1 S21 LOG 6 dB / REF 0 dB

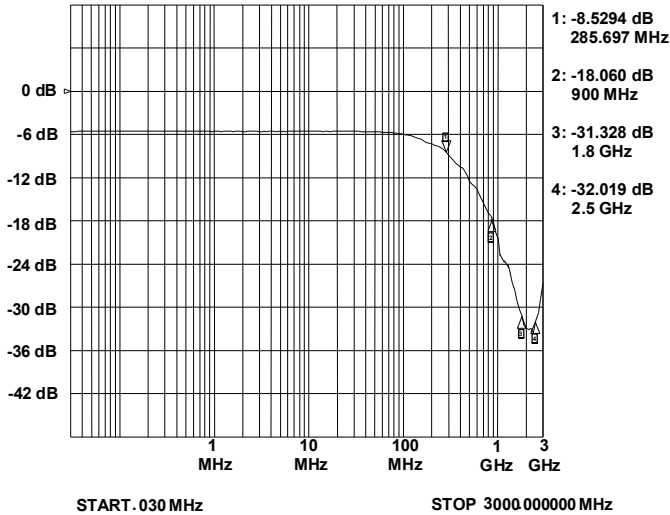

### Analog Crosstalk (Each Line)

CH1 S21 LOG 6 dB / REF 0 dB



### ESD Clamping (+8kV Contact)

Tek Run: 1.00GS/s Sample 1713

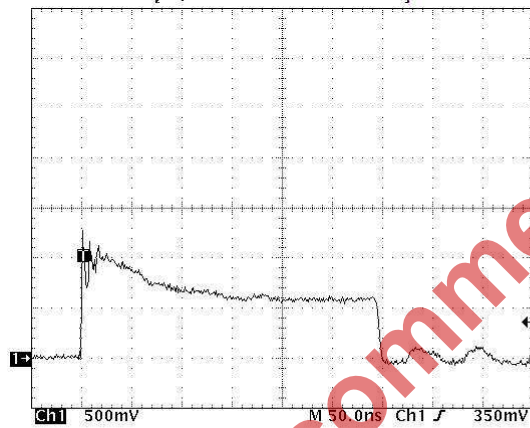

### ESD Clamping (-8kV Contact)

Tek Run: 2.50GS/s Sample 1713

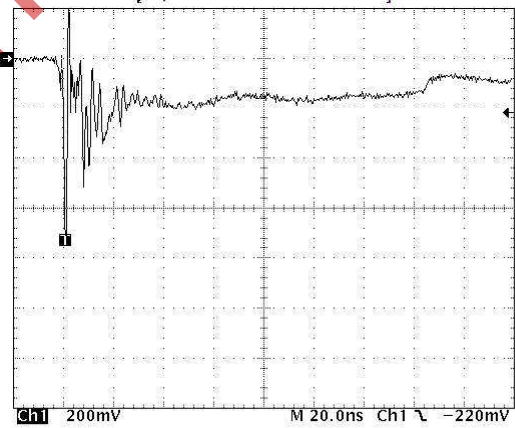

### Capacitance vs. Reverse Voltage (Normalized to 0 volts)

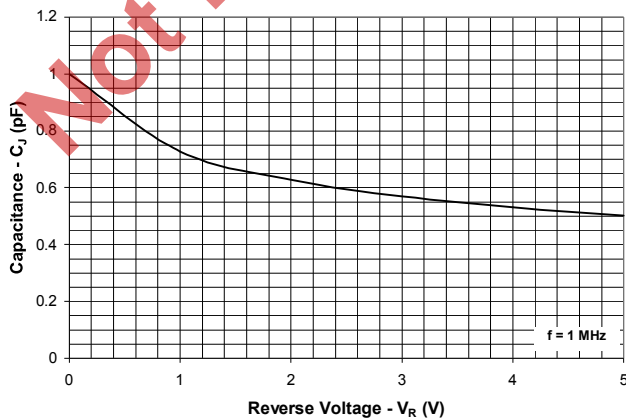

### Series Resistance vs. Temperature (Normalized to 25 Degrees Celcius)

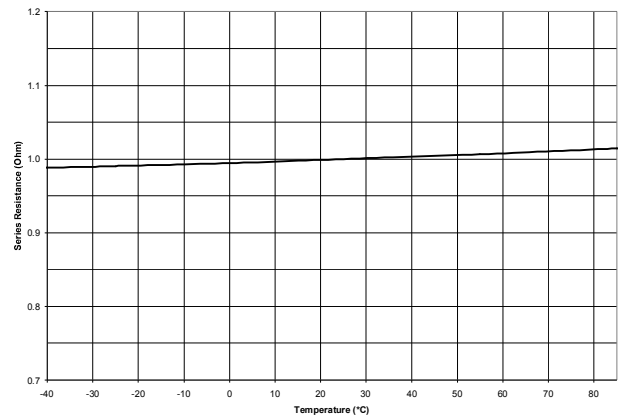

## PROTECTION PRODUCTS

### Applications Information

#### Device Connection

The EClamp2357N is comprised of six circuits each consisting of a low pass filter for EMI/RFI suppression and dual TVS diodes for ESD protection. It also includes 4 lines of TVS diodes for ESD protection of power lines or high speed I/O lines. The device is housed in a 16-pin Quad Flat No-Lead (QFN) package. Electrical connection is made via 16 pins located at the bottom of the device. A center tab serves as the ground connection. Pin connections are noted in the table to the right. The device is designed for easy PCB routing as shown in the application examples. All path lengths should be kept as short as possible to minimize the effects of parasitic inductance in the board traces.

#### Matte Tin Lead Finish

Matte tin has become the industry standard lead-free replacement for SnPb lead finishes. A matte tin finish is composed of 100% tin solder with large grains. Since the solder volume on the leads is small compared to the solder paste volume that is placed on the land pattern of the PCB, the reflow profile will be determined by the requirements of the solder paste. Therefore, these devices are compatible with both lead-free and SnPb assembly techniques. In addition, unlike other lead-free compositions, matte tin does not have any added alloys that can cause degradation of the solder joint.

#### Pin Identification and Configuration (Top Side View)

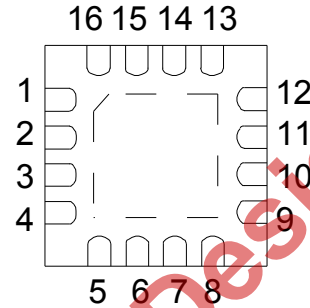

Pin	Identification
3, 4, 5, 7, 9, 10	Input EMI/ESD Protected Lines
1, 2, 11, 12, 14, 16	Output EMI/ESD Protected Lines
6, 8, 13, 15	Input/Output ESD Protected Lines
Center Tab	Ground

#### Pin Configuration and Schematic

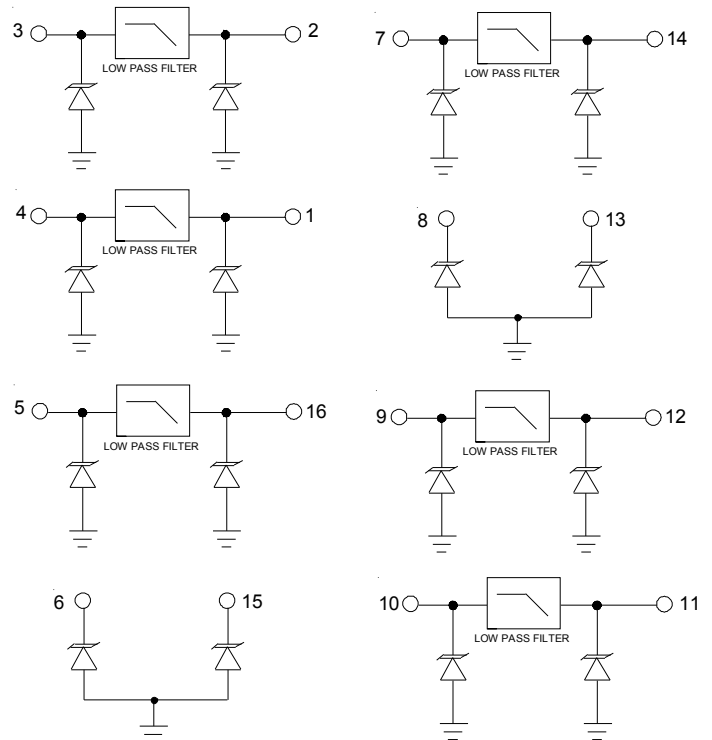

PROTECTION PRODUCTS

Typical Applications

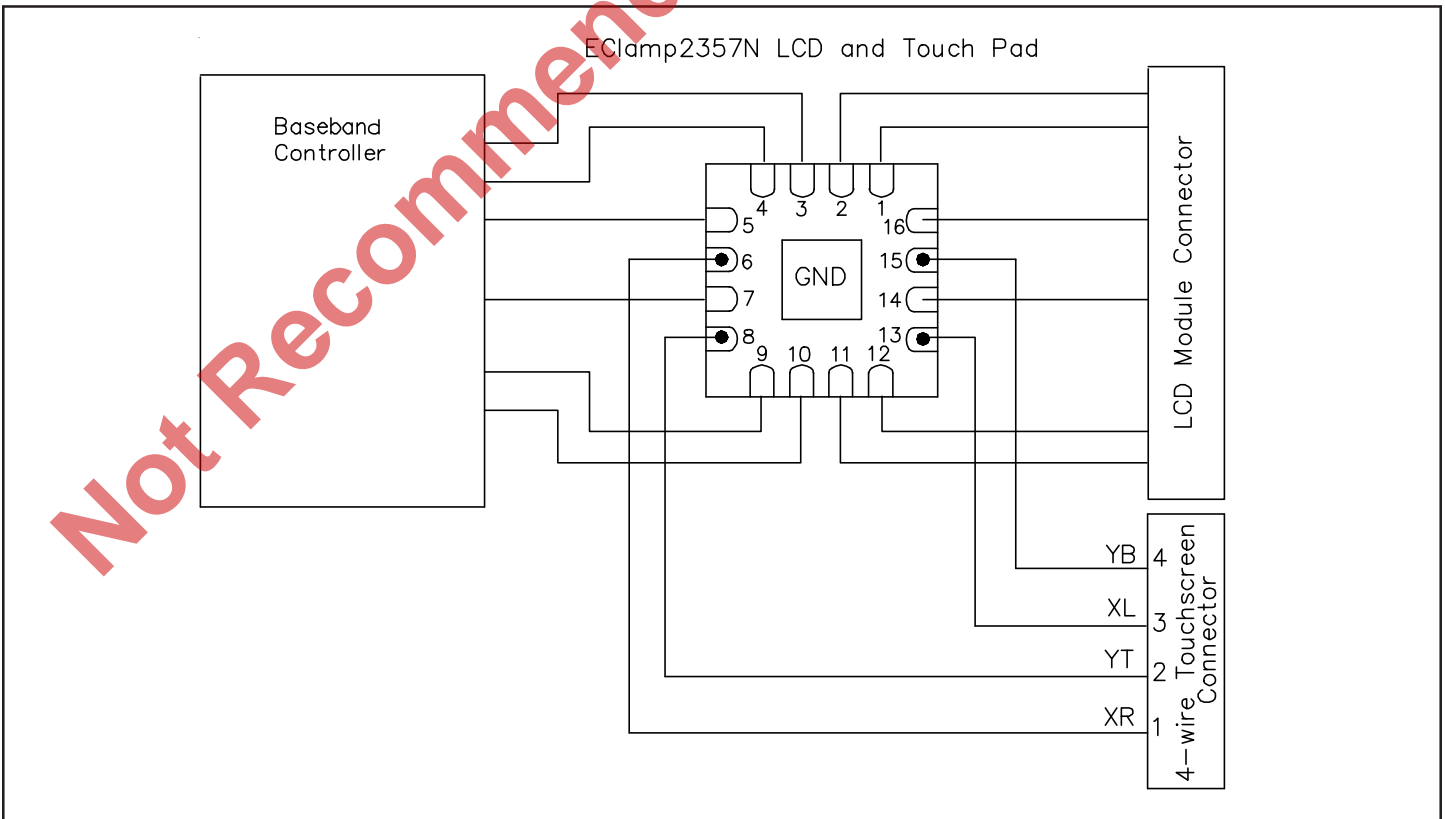
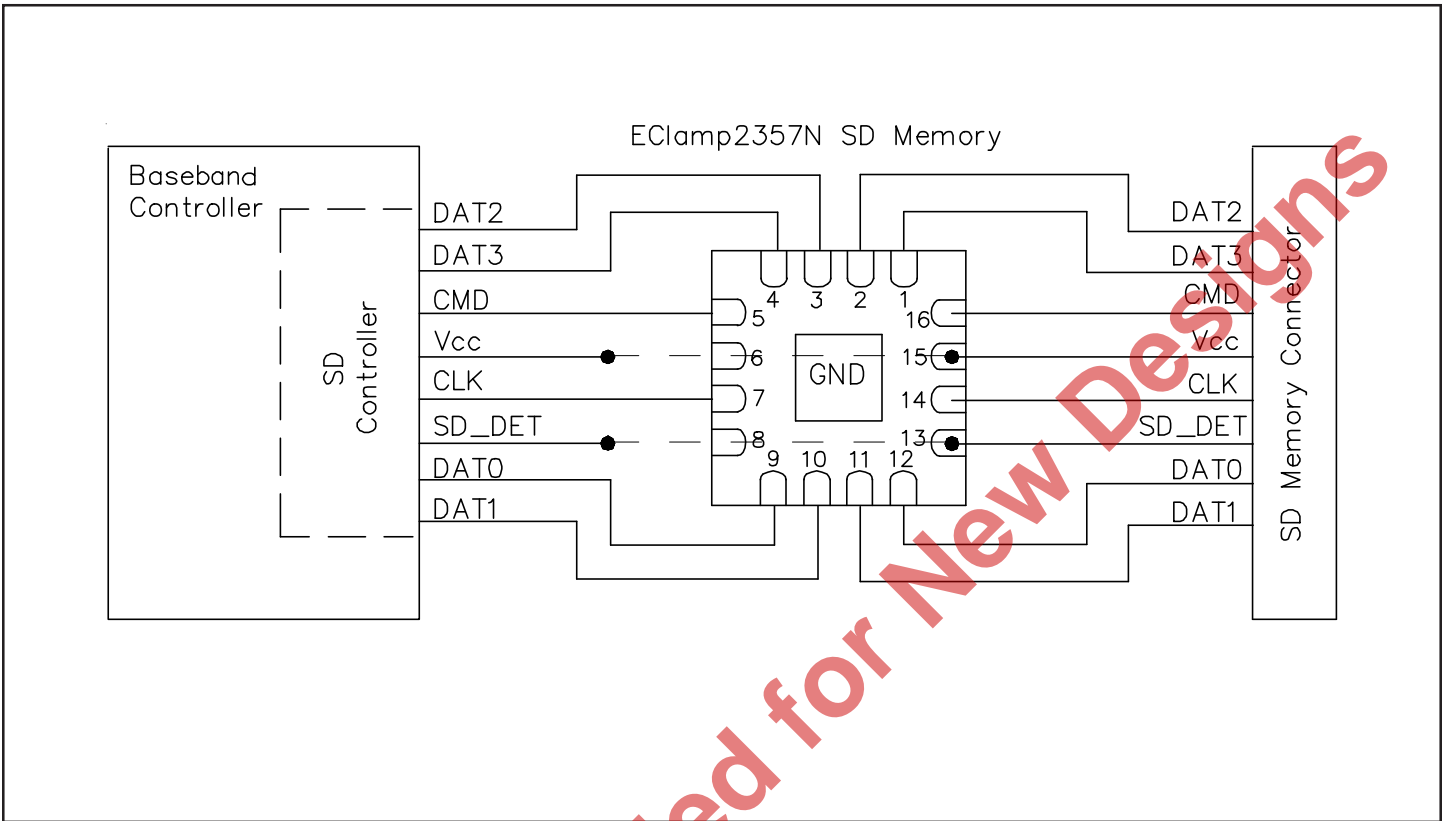

PROTECTION PRODUCTS

Outline Drawing - 16L QFN

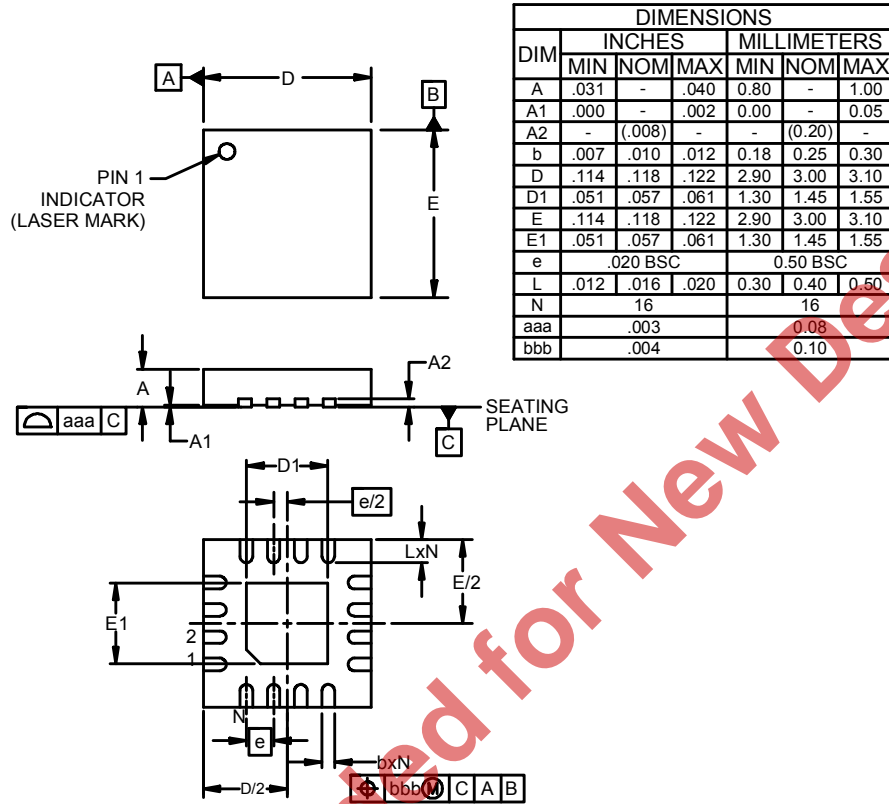

- NOTES:
1. CONTROLLING DIMENSIONS ARE IN MILLIMETERS (ANGLES IN DEGREES).
  2. COPLANARITY APPLIES TO THE EXPOSED PAD AS WELL AS THE TERMINALS.

Land Pattern - 16L QFN

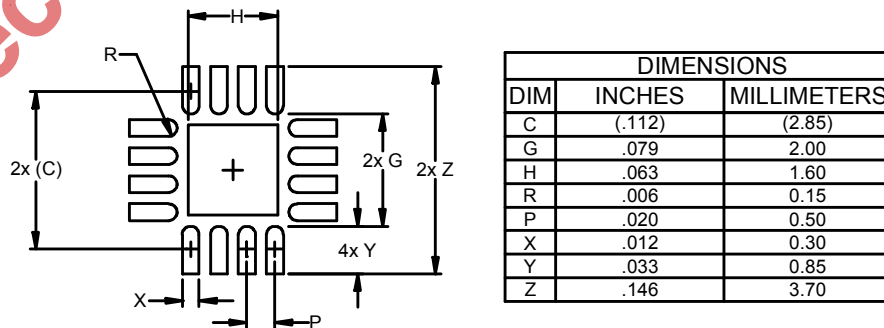

- NOTES:
1. THIS LAND PATTERN IS FOR REFERENCE PURPOSES ONLY. CONSULT YOUR MANUFACTURING GROUP TO ENSURE YOUR COMPANY'S MANUFACTURING GUIDELINES ARE MET.

## PROTECTION PRODUCTS

### Marking

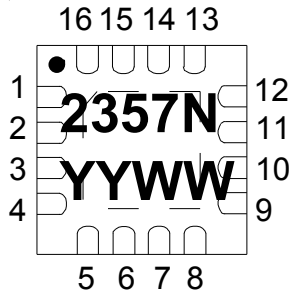

**Top View Showing Device Marking**

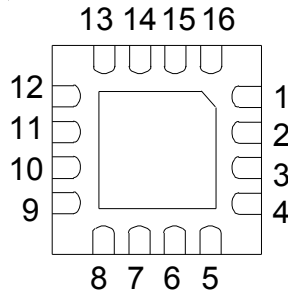

**Bottom View Showing Pin 1 Identifier**

### Ordering Information

Part Number	Qty per Reel	Reel Size
EClamp2357N.TCT	3000	7 Inch

EClamp and EMIClamp are marks of Semtech Corporation

### Notes:

- 1) YYWW = Date Code
- 2) Pin 1 indicated by bevel on the ground pad

### Tape and Reel Specification

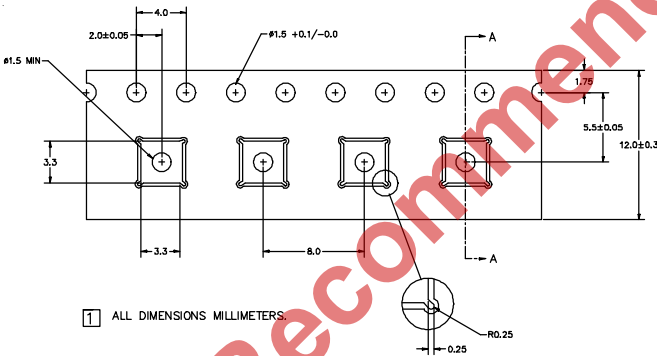

**Tape Specifications**

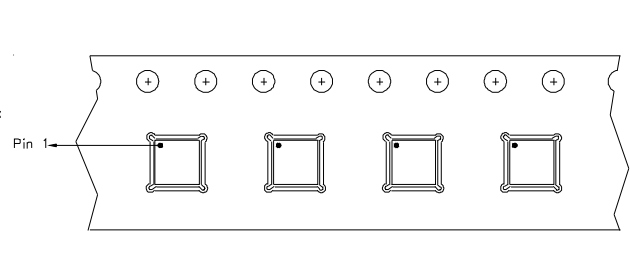

**Device Orientation in Tape**

### Contact Information

Semtech Corporation  
 Protection Products Division  
 200 Flynn Rd., Camarillo, CA 93012  
 Phone: (805)498-2111 FAX (805)498-3804

## Looking for pricing, stock, or lifecycle information?

Click below to explore more details on WIN SOURCE:

- ⊖ [View ECLAMP2357N.TCT on WIN SOURCE](#)
- ⊖ [Semtech Corporation](#) Information

## Optimize Your Supply Chain with WIN SOURCE Solutions

- ✓ Global Sourcing Solution
- ✓ Obsolete Management
- ✓ Cost Control Management
- ✓ Shortage Management
- ✓ Alternative Solution
- ✓ Excess Inventory Management