



## DCP02x 2-W, Isolated, Unregulated DC/DC Converter Modules

### 1 Features

- 1-kV Isolation (Operational)
- Device-to-Device Synchronization
- EN55022 Class B EMC Performance
- UL1950 Recognized Component
- 7-Pin PDIP and 12-Pin SOP Packages

### 2 Applications

- Signal Path Isolation
- Ground Loop Elimination
- Data Acquisition
- Industrial Control and Instrumentation
- Test Equipment

### 3 Description

The DCP02 series is a family of 2-W, isolated, unregulated DC/DC converter modules. Requiring a minimum of external components and including on-chip device protection, the DCP02 series of devices provide extra features such as output disable and synchronization of switching frequencies.

This combination of features and small size makes the DCP02 series of devices suitable for a wide range of applications, and is an easy-to-use solution in applications requiring signal path isolation.

**WARNING:** This product has operational isolation and is intended for signal isolation only. It should not be used as a part of a safety isolation circuit requiring reinforced isolation. See definitions in the [Feature Description](#) section.

#### Device Information<sup>(1)</sup>

PART NUMBER	PACKAGE	BODY SIZE (NOM)
DCP02xxxx	PDIP (7)	19.18 mm x 10.60 mm
	SOP (12)	17.90 mm x 10.33 mm

(1) For all available packages, see the orderable addendum at the end of the data sheet.

Single Output Block Diagram

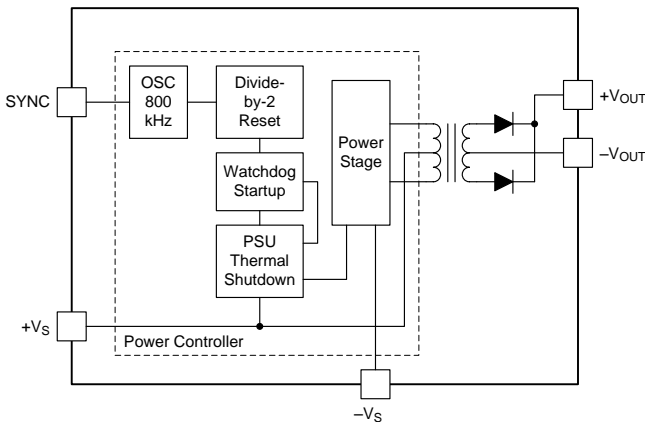

Dual Output Block Diagram

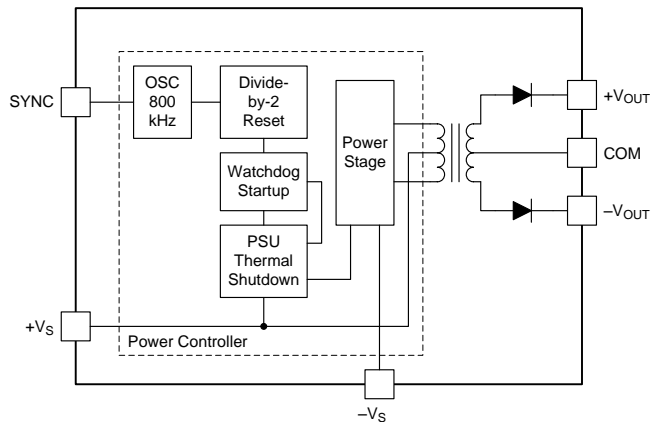

## Table of Contents

<b>1 Features</b> .....	1	8.4 Device Functional Modes.....	11
<b>2 Applications</b> .....	1	<b>9 Application and Implementation</b> .....	13
<b>3 Description</b> .....	1	9.1 Application Information.....	13
<b>4 Revision History</b> .....	2	9.2 Typical Application .....	13
<b>5 Device Comparison Table</b> .....	3	<b>10 Power Supply Recommendations</b> .....	16
<b>6 Pin Configuration and Functions</b> .....	4	<b>11 Layout</b> .....	17
<b>7 Specifications</b> .....	5	11.1 Layout Guidelines .....	17
7.1 Absolute Maximum Ratings .....	5	11.2 Layout Example .....	17
7.2 ESD Ratings .....	5	<b>12 Device and Documentation Support</b> .....	19
7.3 Recommended Operating Conditions.....	5	12.1 Device Support .....	19
7.4 Thermal Information .....	5	12.2 Documentation Support .....	19
7.5 Electrical Characteristics.....	6	12.3 Community Resources.....	19
7.6 Switching Characteristics .....	6	12.4 Related Links .....	20
7.7 Typical Characteristics .....	7	12.5 Trademarks .....	20
<b>8 Detailed Description</b> .....	8	12.6 Electrostatic Discharge Caution.....	20
8.1 Overview .....	8	12.7 Glossary .....	20
8.2 Functional Block Diagrams .....	8	<b>13 Mechanical, Packaging, and Orderable Information</b> .....	20
8.3 Feature Description.....	9		

## 4 Revision History

Changes from Revision K (February 2008) to Revision L	Page
• Updated <a href="#">Features</a> .....	1
• Added <i>ESD Ratings</i> table, <i>Feature Description</i> section, <i>Device Functional Modes</i> section, <i>Application and Implementation</i> section, <i>Power Supply Recommendations</i> section, <i>Layout</i> section, <i>Device and Documentation Support</i> section, and <i>Mechanical, Packaging, and Orderable Information</i> section.....	1
• Added <a href="#">Dual Output Block Diagram</a> .....	1
• Renamed pin " <b>0V</b> " to " <b>COM</b> " (output side common pin) in table.....	4
• Renamed pin " <b>V<sub>S</sub></b> " to " <b>+V<sub>S</sub></b> " (input voltage pin) in table .....	4
• Renamed pin " <b>0V</b> " to " <b>-V<sub>S</sub></b> " (input side common pin) in table .....	4
• Added <a href="#">Recommended Operating Conditions</a> table .....	5
• Added <a href="#">Thermal Information</a> table .....	5
• Added information to the ISOLATION section of the <a href="#">Electrical Characteristics</a> table .....	6
• Added <a href="#">Isolation</a> section to the <i>Feature Description</i> section .....	9
• Added a typical application design to the <i>Application Information</i> section.....	13

## 5 Device Comparison Table

DEVICE NUMBER	INPUT VOLTAGE $V_s$ (V)			OUTPUT VOLTAGE $V_{NOM}$ @ $V_s$ (TYP)(V) 75% LOAD			DEVICE OUTPUT CURRENT (mA) <sup>(1)</sup>	LOAD REGULATION 10% TO 100% LOAD <sup>(2)</sup>		NO LOAD CURRENT $I_q$ (mA) 0% LOAD	EFFICIENCY (%) 100% LOAD	BARRIER CAPACITANCE $C_{iso}$ (pF) $V_{iso} = 750V_{rms}$
	MIN	TYP	MAX	MIN	TYP	MAX		MAX	TYP			
DCP020503P DCP020503U	4.5	5	5.5	3.13	3.3	3.46	600	19	30	18	74	26
DCP020505P DCP020505U				4.75	5	5.25	400	14	20	18	80	22
DCP020507P DCP020507U				6.65	7	7.35	285	14	25	20	81	30
DCP020509P DCP020509U				8.55	9	9.45	222	12	20	23	82	31
DCP020515DP DCP020515DU				±14.25	±15	±15.75	133 <sup>(3)</sup>	11	20	27	85	24
DCP021205P DCP021205U	10.8	12	13.2	4.75	5	5.25	400	7	15	14	83	33
DCP021212P DCP021212U				11.4	12	12.6	166	7	20	15	87	47
DCP021212DP DCP021212DU				±11.4	±12	±12.6	166 <sup>(3)</sup>	6	20	16	88	35
DCP021515P DCP021515U	13.5	15	16.5	14.25	15	15.75	133	6	20	15	88	42
DCP022405P DCP022405U	21.6	24	26.4	4.75	5	5.25	400	6	15	13	81	33
DCP022405DP DCP022405DU				±4.75	±5	±5.25	400 <sup>(3)</sup>	6	15	12	80	22
DCP022415DP DCP022415DU				±14.25	±15	±15.75	133 <sup>(3)</sup>	6	25	16	79	44

(1)  $P_{OUT(max)} = 2\text{ W}$

(2) Load regulation =  $(V_{OUT}$  at 10% load –  $V_{OUT}$  at 100%)/ $V_{OUT}$  at 75% load

(3)  $I_{OUT1} + I_{OUT2}$

## 6 Pin Configuration and Functions



### Pin Functions

PIN NAME	NUMBER				I/O <sup>(1)</sup>	DESCRIPTION
	DVB (DUAL)	DVB (SINGLE)	NVA (DUAL)	NVA (SINGLE)		
COM	12	—	5	—	O	Output side common
NC	15	14	8	7	—	No connection
	16	16		8		
	17	17				
	26	26				
	27	27				
SYNC	28	28	14	14	I	Synchronization Pin - Synchronize multiple devices by connecting their SYNC pins together. Pulling this pin low disables the internal oscillator.
+V <sub>OUT</sub>	13	13	6	6	O	Positive output voltage
-V <sub>OUT</sub>	14	12	7	5	O	Negative output voltage
+V <sub>S</sub>	1	1	1	1	I	Input voltage
-V <sub>S</sub>	2	2	2	2	I	Input side common
	3	3				

(1) I = Input, O = Output

## 7 Specifications

### 7.1 Absolute Maximum Ratings

over operating free-air temperature range (unless otherwise noted) <sup>(1)</sup>

		MIN	MAX	UNIT
Input voltage	5-V input devices		7	V
	12-V input devices		15	
	15-V input devices		18	
	24-V input devices		29	
Storage temperature, T <sub>stg</sub>		-60	125	°C

(1) Stresses beyond those listed under *Absolute Maximum Ratings* may cause permanent damage to the device. These are stress ratings only, which do not imply functional operation of the device at these or any other conditions beyond those indicated under *Recommended Operating Conditions*. Exposure to absolute-maximum-rated conditions for extended periods may affect device reliability.

### 7.2 ESD Ratings

		VALUE	UNIT
V <sub>(ESD)</sub> Electrostatic discharge	Human-body model (HBM), per ANSI/ESDA/JEDEC JS-001 <sup>(1)</sup>	±1000	V
	Charged-device model (CDM), per JEDEC specification JESD22-C101 <sup>(2)</sup>	±250	

(1) JEDEC document JEP155 states that 500-V HBM allows safe manufacturing with a standard ESD control process.

(2) JEDEC document JEP157 states that 250-V CDM allows safe manufacturing with a standard ESD control process.

### 7.3 Recommended Operating Conditions

over operating free-air temperature range (unless otherwise noted)

		MIN	NOM	MAX	UNIT
Input Voltage	5-V input devices	4.5	5	5.5	V
	12-V input devices	10.8	12	13.2	
	15-V input devices	13.5	15	16.5	
	24-V input devices	21.6	24	26.4	
Operating temperature		-40		85	°C

### 7.4 Thermal Information

THERMAL METRIC <sup>(1)</sup>		DCP020x	DCP020x	UNIT
		NVA (PDIP)	DVB (SOP)	
		7 PINS	12 PINS	
R <sub>θJA</sub>	Junction-to-ambient thermal resistance	61	61	°C/W
R <sub>θJC(top)</sub>	Junction-to-case (top) thermal resistance	19	19	
R <sub>θJB</sub>	Junction-to-board thermal resistance	24	24	
Ψ <sub>JT</sub>	Junction-to-top characterization parameter	7	7	
Ψ <sub>JB</sub>	Junction-to-board characterization parameter	24	24	
R <sub>θJC(bot)</sub>	Junction-to-case (bottom) thermal resistance	N/A	N/A	

(1) For more information about traditional and new thermal metrics, see the *Semiconductor and IC Package Thermal Metrics* application report, [SPRA953](#).

## 7.5 Electrical Characteristics

over operating free-air temperature range (unless otherwise noted)

PARAMETER		TEST CONDITIONS	MIN	TYP	MAX	UNIT
<b>OUTPUT</b>						
$P_{OUT}$	Output power	$I_{LOAD} = 100\%$ (full load)			2	W
$V_{RIPPLE}$	Output voltage ripple	$C_{OUT} = 1 \mu F$ , $I_{LOAD} = 50\%$		20		mV <sub>PP</sub>
	Voltage vs. Temperature	$-40^{\circ}C \leq T_A \leq 25^{\circ}C$		0.046		%/ $^{\circ}C$
		$25^{\circ}C \leq T_A \leq 85^{\circ}C$		0.016		%/ $^{\circ}C$
<b>INPUT</b>						
$V_S$	Input voltage range		-10%		10%	
<b>ISOLATION</b>						
$V_{ISO}$	Isolation	1-second flash test	Voltage	1		kVrms
			dV/dt		500	V/s
			Leakage Current		30	nA
		Continuous working voltage across isolation barrier	DC		60	VDC
			AC		42.5	VAC
<b>LINE REGULATION</b>						
	Output voltage	$I_{OUT} \geq 10\%$ load current and constant, $V_S$ (min) to $V_S$ (typ)		1%	15%	
		$I_{OUT} \geq 10\%$ load current and constant, $V_S$ (typ) to $V_S$ (max)		1%	15%	
<b>RELIABILITY</b>						
	Demonstrated	$T_A = 55^{\circ}C$	75			FITS
<b>THERMAL SHUTDOWN</b>						
$T_{SD}$	Die temperature at shutdown			150		$^{\circ}C$
$I_{SD}$	Shutdown current			3		mA

## 7.6 Switching Characteristics

over operating free-air temperature range (unless otherwise noted)

PARAMETER		TEST CONDITIONS	MIN	TYP	MAX	UNIT
$f_{OSC}$	Oscillator frequency	$f_{SW} = f_{OSC}/2$		800		kHz
$V_{IL}$	Low-level input voltage, SYNC		0		0.4	V
$I_{SYNC}$	Input current, SYNC	$V_{SYNC} = 2 V$		75		$\mu A$
$t_{DISABLE}$	Disable time			2		$\mu s$
$C_{SYNC}$	Capacitance loading on SYNC pin <sup>(1)</sup>	External			3	pF

(1) The application report *External Synchronization of the DCP01/02 Series of DC/DC Converters*([SBAA035](#)) describes this configuration.

## 7.7 Typical Characteristics

T<sub>A</sub> = 25°C, unless otherwise noted.

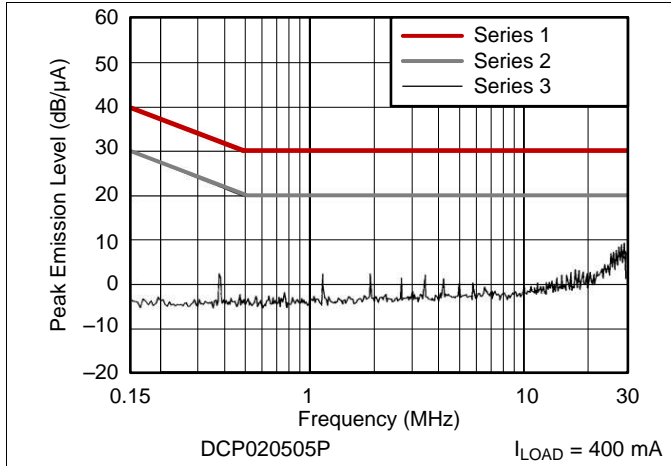

Figure 1. Conducted Emissions vs. Frequency

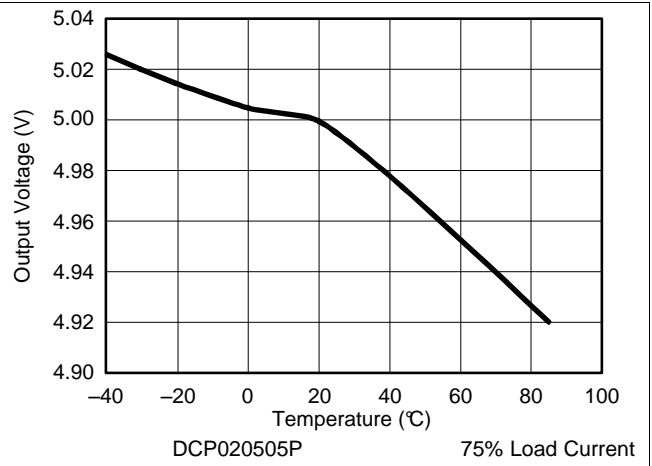

Figure 2. Output Voltage vs. Temperature

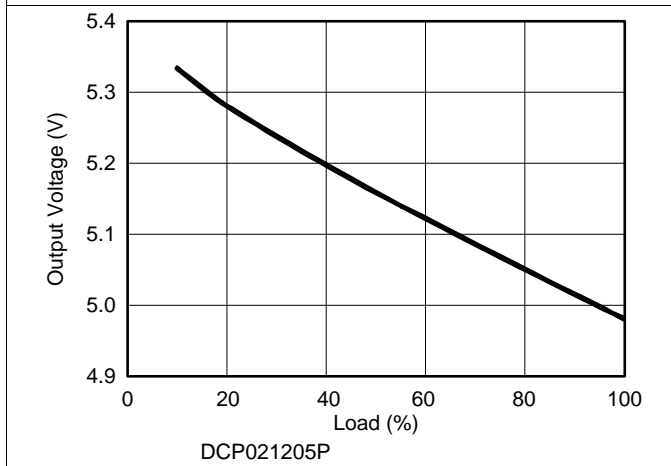

Figure 3. Output Voltage vs. Output Current

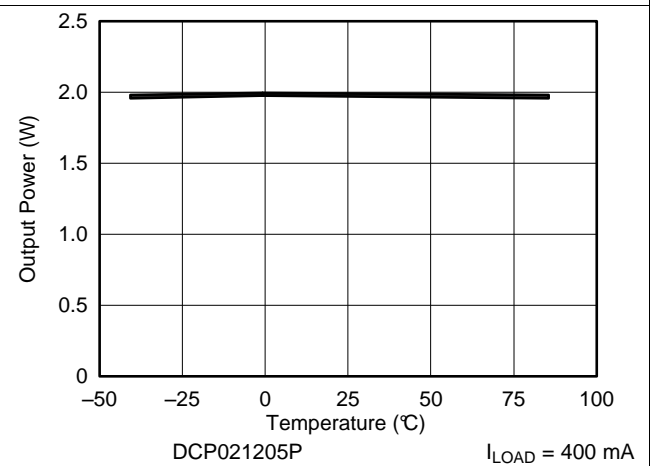

Figure 4. Output Power vs. Temperature

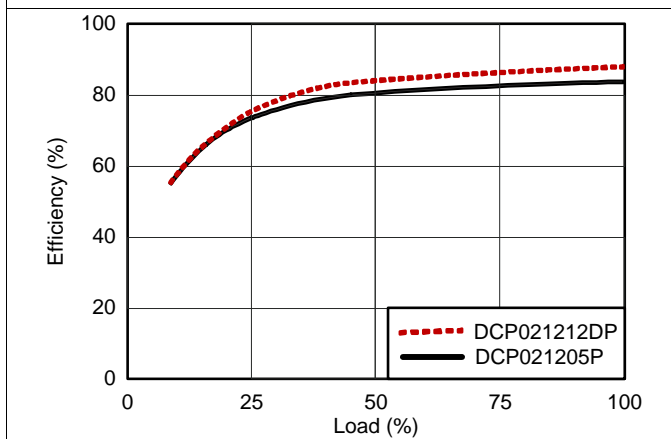

Figure 5. Efficiency vs. Percent Load Current

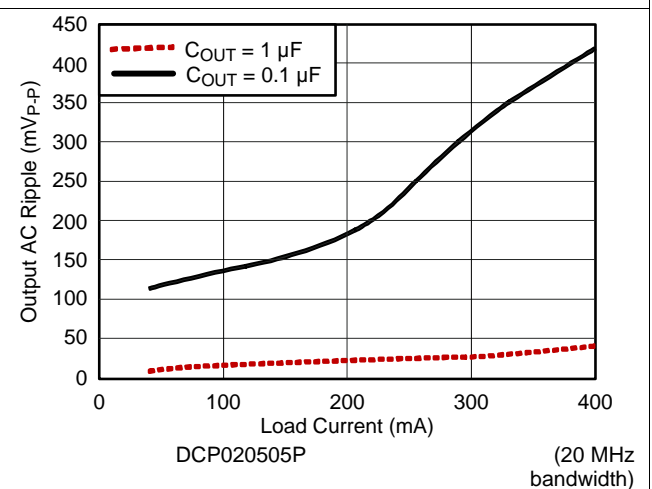

Figure 6. Output AC Ripple vs. Load Current

## 8 Detailed Description

### 8.1 Overview

The DCP02 offers up to 2 W of isolated, unregulated output power from a 5-V, 12-V, 15-V, or 24-V input source with a typical efficiency of up to 89%. This efficiency is achieved through highly integrated packaging technology and the implementation of a custom power stage and control device. The DCP02 devices are specified for operational isolation only. The circuit design uses an advanced BiCMOS/DMOS process.

### 8.2 Functional Block Diagrams

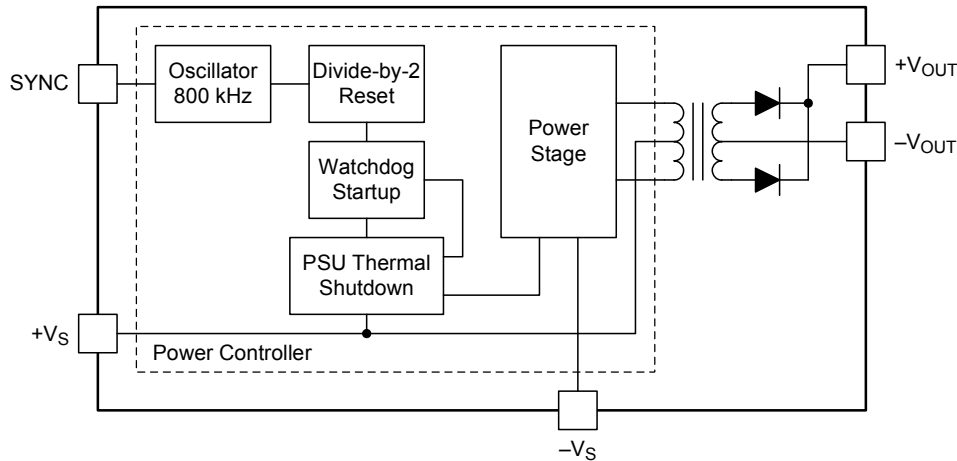

Figure 7. Single Output Device

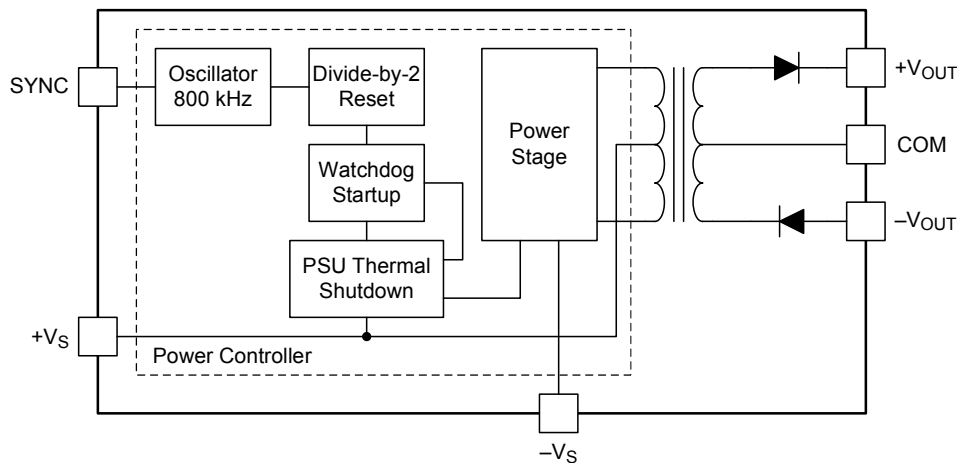

Figure 8. Dual Output Device

## 8.3 Feature Description

### 8.3.1 Isolation

Underwriters Laboratories, UL™ defines several classes of isolation that are used in modern power supplies.

*Safety extra low voltage (SELV)* is defined by UL (UL1950 E199929) as a secondary circuit which is so designated and protected that under normal and single fault conditions the voltage between any two accessible parts, or between an accessible part and the equipment earthing terminal for operational isolation does not exceed steady state 42 V peak or 60 V<sub>DC</sub> for more than 1 second.

#### 8.3.1.1 Operation or Functional Isolation

Operational or functional isolation is defined by the use of a high-potential (hipot) test only. Typically, this isolation is defined as the use of insulated wire in the construction of the transformer as the primary isolation barrier. The hipot one-second duration test (dielectric voltage, withstand test) is a production test used to verify that the isolation barrier is functioning. Products with operational isolation should never be used as an element in a safety-isolation system.

#### 8.3.1.2 Basic or Enhanced Isolation

Basic or enhanced isolation is defined by specified creepage and clearance limits between the primary and secondary circuits of the power supply. Basic isolation is the use of an isolation barrier in addition to the insulated wire in the construction of the transformer. Input and output circuits must also be physically separated by specified distances.

#### 8.3.1.3 Continuous Voltage

For a device that has no specific safety agency approvals (operational isolation), the continuous voltage that can be applied across the part in normal operation is less than 42.4 V<sub>RMS</sub>, or 60 V<sub>DC</sub>. Ensure that both input and output voltages maintain normal SELV limits. The isolation test voltage represents a measure of immunity to transient voltages.

#### WARNING

**Do not use the device as an element of a safety isolation system when SELV is exceeded**

If the device is expected to function correctly with more than 42.4 V<sub>RMS</sub> or 60 V<sub>DC</sub> applied continuously across the isolation barrier, then the circuitry on both sides of the barrier must be regarded as operating at an unsafe voltage, and further isolation or insulation systems must form a barrier between these circuits and any user-accessible circuitry according to safety standard requirements.

#### 8.3.1.4 Isolation Voltage

*Hipot test, flash-tested, withstand voltage, proof voltage, dielectric withstand voltage, and isolation test voltage* are all terms that relate to the same thing: a test voltage applied for a specified time across a component designed to provide electrical isolation to verify the integrity of that isolation. TI's DCP02 series of dc-dc converters are all 100% production tested at 1.0 kV<sub>AC</sub> for one second.

#### 8.3.1.5 Repeated High-Voltage Isolation Testing

Repeated high-voltage isolation testing of a barrier component can degrade the isolation capability, depending on materials, construction, and environment. The DCP02 series of dc-dc converters have toroidal, enameled, wire isolation transformers with no additional insulation between the primary and secondary windings. While a device can be expected to withstand several times the stated test voltage, the isolation capability depends on the wire insulation. Any material, including this enamel (typically polyurethane), is susceptible to eventual chemical degradation when subject to very-high applied voltages. Therefore, strictly limit the number of high-voltage tests and repeated high-voltage isolation testing. However, if it is absolutely required, reduce the voltage by 20% from specified test voltage with a duration limit of one second per test.

## Feature Description (continued)

### 8.3.2 Power Stage

The DCP02 series of devices use a push-pull, center-tapped topology. The DCP02 devices switch at 400 kHz (divide-by-2 from an 800-kHz oscillator).

### 8.3.3 Oscillator And Watchdog Circuit

The onboard, 800-kHz oscillator generates the switching frequency via a divide-by-2 circuit. The oscillator can be synchronized to other DCP02-series device circuits or an external source, and is used to minimize system noise.

A watchdog circuit checks the operation of the oscillator circuit. The oscillator can be disabled by pulling the SYNC pin low. When the SYNC pin goes low, the output pins transition into tri-state mode, which occurs within 2  $\mu$ s.

### 8.3.4 Thermal Shutdown

The DCP02 series of devices are protected by a thermal-shutdown circuit.

If the on-chip temperature rises above 150°C, the device shuts down. Normal operation resumes as soon as the temperature falls below 150°C.

### 8.3.5 Synchronization

In the event that more than one DC/DC converter is needed onboard, beat frequencies and other electrical interference can be generated. This interference occurs because of the small variations in switching frequencies between the DC/DC converters.

The DCP02 series of devices overcome this interference by allowing devices to be synchronized to one another. Up to eight devices can be synchronized by connecting the SYNC pins together, taking care to minimize the capacitance of tracking. Stray capacitance (greater than 3 pF) has the effect of reducing the switching frequency, or even stopping the oscillator circuit. The maximum recommended voltage applied to the SYNC pin is 3.0 V.

For an application that uses more than eight synchronized devices use an external device to drive the SYNC pins. The application report *External Synchronization of the DCP01/02 Series of DC/DC Converters* ([SBAA035](#)) describes this configuration.

---

#### NOTE

**During the start-up period, all synchronized devices draw maximum current from the input simultaneously. If the input voltage falls below approximately 4 V, the devices may not start up. A 2.2- $\mu$ F capacitor should be connected close to each device's input pin.**

---

### 8.3.6 Construction

The basic construction of the DCP02 series of devices is the same as standard integrated circuits. The molded package contains no substrate. The DCP02 series of devices are constructed using an IC, rectifier diodes, and a wound magnetic toroid on a leadframe. Because the package contains no solder, the devices do not require any special printed circuit board (PCB) assembly processing. This architecture results in an isolated DC/DC converter with inherently high reliability.

### 8.3.7 Thermal Management

Due to the high power density of this device, it is advisable to provide ground planes on the input and output.

## 8.4 Device Functional Modes

### 8.4.1 Disable/Enable (SYNC pin)

Any of the DCP02 series devices can be disabled or enabled by driving the SYNC pin using an open drain CMOS gate. If the SYNC pin is pulled low, the DCP02 becomes disabled. The disable time depends upon the external loading. The internal disable function is implemented in 2  $\mu$ s. Removal of the pull down causes the DCP02 to be enabled.

Capacitive loading on the SYNC pin should be minimized ( $\leq 3$  pF) in order to prevent a reduction in the oscillator frequency. The application report *External Synchronization of the DCP01/02 Series of DC/DC Converters* (SBAA035) describes disable/enable control circuitry.

### 8.4.2 Decoupling

#### 8.4.2.1 Ripple Reduction

The high switching frequency of 400 kHz allows simple filtering. To reduce ripple, it is recommended that a minimum of 1- $\mu$ F capacitor be used on the  $V_{OUT}$  pin. For dual output devices, decouple both of the outputs to the COM pin. A 2.2- $\mu$ F capacitor on the input is also recommended.

#### 8.4.2.2 Connecting the DCP02 in Series

Multiple DCP02 isolated 2W DC/DC converters can be connected in series to provide non-standard voltage rails. This configuration is possible by using the floating outputs provided by the galvanic isolation of the DCP02.

Connect the  $+V_{OUT}$  from one DCP02 to the  $-V_{OUT}$  of another (see Figure 9). If the SYNC pins are tied together, the self-synchronization feature of the DCP02 prevents beat frequencies on the voltage rails. The SYNC feature of the DCP02 allows easy series connection without external filtering, thus minimizing cost.

The outputs of a dual-output DCP02 can also be connected in series to provide two times the magnitude of  $V_{OUT}$ , as shown in Figure 10. For example, connect a dual-output, 15-V, DCP022415D device to provide a 30-V rail.

All 5-V, 12-V, and 15-V input voltage designs require a 2.2- $\mu$ F, low-ESR ceramic input capacitor, while 24-V input applications require only 0.47  $\mu$ F of input capacitance.



Figure 9. Multiple DCP02 Devices Connected in Series



Figure 10. Dual Output Devices Connected in Series

### 8.4.2.3 Connecting the DCP02 in Parallel

If the output power from one DCP02 is not sufficient, it is possible to parallel the outputs of multiple DCP02s, as shown in Figure 11, ( applies to single output devices only). The SYNC feature allows easy synchronization to prevent power-rail beat frequencies at no additional filtering cost.

All 5-V, 12-V, and 15-V input voltage designs require a 2.2- $\mu$ F, low-ESR, ceramic input capacitor, while 24-V input applications require only 0.47  $\mu$ F of input capacitance.



Figure 11. Multiple DCP02 Devices Connected in Parallel

## 9 Application and Implementation

### NOTE

Information in the following applications sections is not part of the TI component specification, and TI does not warrant its accuracy or completeness. TI's customers are responsible for determining suitability of components for their purposes. Customers should validate and test their design implementation to confirm system functionality.

### 9.1 Application Information

### 9.2 Typical Application

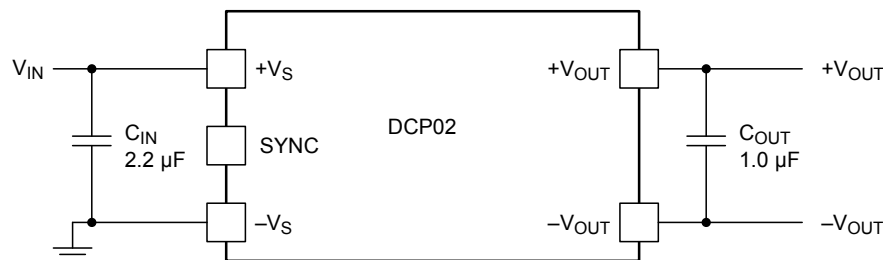

Figure 12. Typical DCP020505 Application

#### 9.2.1 Design Requirements

For this design example, use the parameters listed in [Table 1](#) and follow the design procedures shown in [Detailed Design Procedure](#) section.

Table 1. Design Example Parameters

PARAMETER		VALUE	UNIT
$V_{(+VS)}$	Input voltage	5	V
$V_{(+VOUT)}$	Output voltage	5	V
$I_{OUT}$	Output current rating	400	mA
$f_{SW}$	Operating frequency	400	kHz

#### 9.2.2 DCP020505 Application Curves

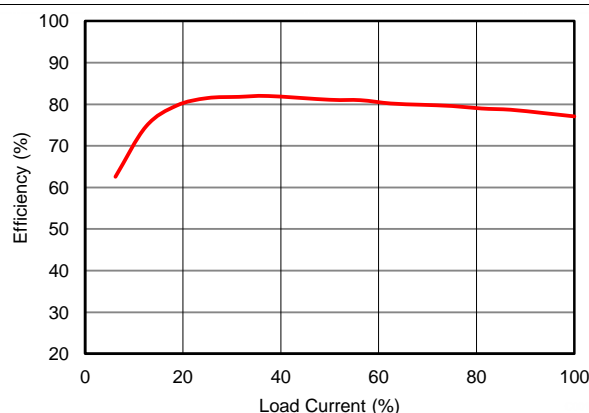

Figure 13. DCP020505 Efficiency

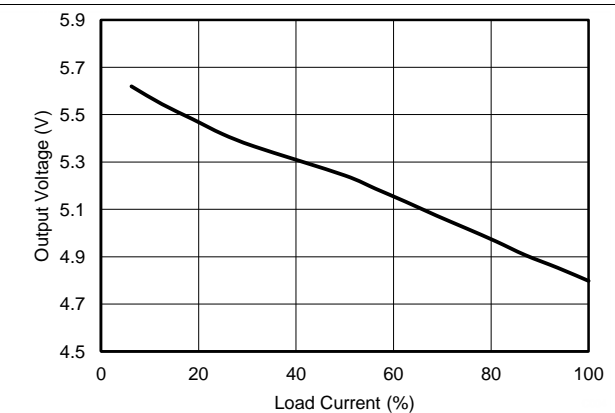

Figure 14. DCP020505 Load Regulation

## 9.2.3 Detailed Design Procedure

### 9.2.3.1 Input Capacitor

For all 5-V, 12-V, and 15-V input voltage designs, select a 2.2- $\mu\text{F}$  low-ESR ceramic input capacitor to ensure a good startup performance. 24-V input applications require only 0.47- $\mu\text{F}$  of input capacitance.

### 9.2.3.2 Output Capacitor

For any DCP02 design, select a 1.0- $\mu\text{F}$  low-ESR ceramic output capacitor to reduce output ripple.

### 9.2.3.3 SYNC Pin

In a stand-alone application, leave the SYNC pin floating.

## 9.2.4 PCB Design

The copper losses (resistance and inductance) can be minimized by the use of mutual ground and power planes (tracks) where possible. If that is not possible, use wide tracks to reduce the losses. If several devices are being powered from a common power source, a star-connected system for the track must be deployed; devices must not be connected in series, as this will cascade the resistive losses. The position of the decoupling capacitors is important. They must be as close to the devices as possible in order to reduce losses. See the [PCB Layout](#) section for more details.

## 9.2.5 Decoupling Ceramic Capacitors

All capacitors have losses because of internal equivalent series resistance (ESR), and to a lesser degree, equivalent series inductance (ESL). Values for ESL are not always easy to obtain. However, some manufacturers provide graphs of frequency versus capacitor impedance. These graphs typically show the capacitor impedance falling as frequency is increased (as shown in [Figure 15](#)). In [Figure 15](#),  $X_C$  is the reactance due to the capacitance,  $X_L$  is the reactance due to the ESL, and  $f_0$  is the resonant frequency. As the frequency increases, the impedance stops decreasing and begins to rise. The point of minimum impedance indicates the resonant frequency of the capacitor. This frequency is where the components of capacitance and inductance reactance are of equal magnitude. Beyond this point, the capacitor is not effective as a capacitor.

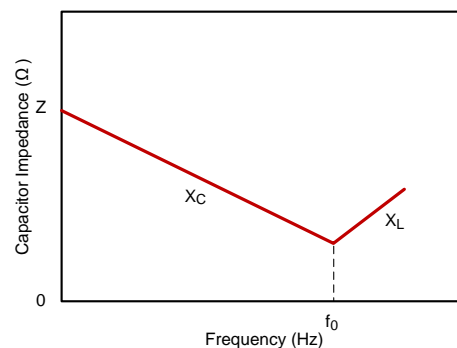

**Figure 15. Capacitor Impedance vs Frequency**

At  $f_0$ ,  $X_C = X_L$ ; however, there is a 180° phase difference resulting in cancellation of the imaginary component. The resulting effect is that the impedance at the resonant point is the real part of the complex impedance; namely, the value of the ESR. The resonant frequency must be well above the 800-kHz switching frequency of the DCP and DCVs.

The effect of the ESR is to cause a voltage drop within the capacitor. The value of this voltage drop is simply the product of the ESR and the transient load current, as shown in [Equation 1](#).

$$V_{IN} = V_{PK} - (ESR \times I_{TR})$$

where

- $V_{IN}$  is the voltage at the device input
  - $V_{PK}$  is the maximum value of the voltage on the capacitor during charge
  - $I_{TR}$  is the transient load current
- (1)

The other factor that affects the performance is the value of the capacitance. However, for the input and the full wave outputs (single-output voltage devices), ESR is the dominant factor.

### 9.2.6 Input Capacitor and the Effects of ESR

If the input decoupling capacitor is not ceramic (and has an ESR greater than 20 mΩ), then at the instant the power transistors switch on, the voltage at the input pins falls momentarily. If the voltage falls below approximately 4 V, the DCP detects an undervoltage condition and switches the DCP drive circuits to the off state. This detection is carried out as a precaution against a genuine low input voltage condition that could slow down or even stop the internal circuits from operating correctly. A slow-down or stoppage results in the drive transistors being turned on too long, causing saturation of the transformer and destruction of the device.

Following detection of a low input voltage condition, the device switches off the internal drive circuits until the input voltage returns to a safe value, at which time the device tries to restart. If the input capacitor is still unable to maintain the input voltage, shutdown recurs. This process repeats until the input capacitor charges sufficiently to start the device correctly.

Normal startup should occur in approximately 1 ms after power is applied to the device. If a considerably longer startup duration time is encountered, it is likely that either (or both) the input supply or the capacitors are not performing adequately.

For 5-V to 15-V input devices, a 2.2-μF, low-ESR ceramic capacitor ensures a good startup performance. For 24-V input voltage devices, 0.47 μF ceramic capacitors are recommended. Tantalum capacitors are not recommended, since most do not have low-ESR values and will degrade performance. If tantalum capacitors must be used, close attention must be paid to both the ESR and voltage as derated by the vendor.

#### NOTE

**During the start-up period, these devices may draw maximum current from the input supply. If the input voltage falls below approximately 4 V, the devices may not start up. Connect a 2.2-μF ceramic capacitor close to the input pins.**

### 9.2.7 Ripple and Noise

A good quality, low-ESR ceramic capacitor placed as close as practical across the input reduces reflected ripple and ensures a smooth startup.

A good quality, low-ESR ceramic capacitor placed as close as practical across the rectifier output terminal and output ground gives the best ripple and noise performance. See *DC-to-DC Converter Noise Reduction (SBVA012)*, for more information on noise rejection.

#### 9.2.7.1 Output Ripple Calculation Example

The following example shows that increasing the capacitance has a much smaller effect on the output ripple voltage than does reducing the value of the ESR for the filter capacitor.

To calculate the output ripple for a DCP020505 device:

- $V_{OUT} = 5 \text{ V}$
- $I_{OUT} = 0.4 \text{ A}$
- At full output power, the load resistor is 12.5Ω
- Output capacitor of 1μF, ESR of 0.1Ω
- Capacitor discharge time 1% of 800 kHz (ripple frequency)

$$t_{DIS} = 0.0125 \mu\text{s}$$

$$\tau = C \times R_{LOAD}$$

$$\tau = 1 \times 10^{-6} \times 12.5 = 12.5 \mu\text{s}$$

$$V_{DIS} = V_O(1 - \text{EXP}(-t_{DIS}/\tau))$$

$$V_{DIS} = 5 \text{ mV}$$

By contrast, the voltage dropped because of ESR:

$$V_{ESR} = I_{LOAD} \times \text{ESR}$$

$$V_{ESR} = 40 \text{ mV}$$

$$\text{Ripple voltage} = 45 \text{ mV}$$

### 9.2.8 Dual DCP02 Output Voltage

The voltage output for dual DCP02 devices is half wave rectified; therefore, the discharge time is 1.25  $\mu\text{s}$ . Repeating the above calculations using the 100% load resistance of 25  $\Omega$  (0.2 A per output), the results are:

$$\tau = 25 \mu\text{s}$$

$$t_{DIS} = 1.25 \mu\text{s}$$

$$V_{DIS} = 244 \text{ mV}$$

$$V_{ESR} = 20 \text{ mV}$$

$$\text{Ripple Voltage} = 266 \text{ mV}$$

This time, it is the capacitor discharging that contributes to the largest component of ripple. Changing the output filter to 10  $\mu\text{F}$ , and repeating the calculations, the result is:

$$\text{Ripple Voltage} = 45 \text{ mV.}$$

This value is composed of almost equal components.

The previous calculations are offered as a guideline only. Capacitor parameters usually have large tolerances and can be susceptible to environmental conditions.

### 9.2.9 Optimizing Performance

Optimum performance can only be achieved if the device is correctly supported. The very nature of a switching converter requires power to be instantly available when it switches on. If the converter has DMOS switching transistors, the fast edges will create a high current demand on the input supply. This transient load placed on the input is supplied by the external input decoupling capacitor, thus maintaining the input voltage. Therefore, the input supply does not see this transient (this is an analogy to high-speed digital circuits). The positioning of the capacitor is critical and must be placed as close as possible to the input pins and connected via a low-impedance path.

The optimum performance primarily depends on two factors:

- Connection of the input and output circuits for minimal loss.
- The ability of the decoupling capacitors to maintain the input and output voltages at a constant level.

## 10 Power Supply Recommendations

The DCP02 is a switching power supply, and as such can place high peak current demands on the input supply. In order to avoid the supply falling momentarily during the fast switching pulses, ground and power planes should be used to connect the power to the input of DCP02. If this connection is not possible, then the supplies must be connected in a star formation with the traces made as wide as possible.

## 11 Layout

### 11.1 Layout Guidelines

Due to the high power density of these devices, provide ground planes on the input and output.

Figure 19 and Figure 17 illustrate a printed circuit board (PCB) layout for the two conventional (DCP01/02, DCV01), and two SOP surface-mount packages (DCP02U). Figure 16 shows the schematic.

Including input power and ground planes provides a low-impedance path for the input power. For the output, the COM signal connects via a ground plane, while the connections for the positive and negative voltage outputs conduct via wide traces in order to minimize losses.

The output should be taken from the device using ground and power planes, thereby ensuring minimum losses.

The location of the decoupling capacitors in close proximity to their respective pins ensures low losses due to the effects of stray inductance, thus improving the ripple performance. This location is of particular importance to the input decoupling capacitor, because this capacitor supplies the transient current associated with the fast switching waveforms of the power drive circuits.

Allow the unused SYNC pin, to remain configured as a floating pad. It is advisable to place a guard ring (connected to input ground) or annulus connected around this pin to avoid any noise pick up. When connecting a SYNC pin to one or more SYNC design the linking trace to be short and narrow to avoid stray capacitance. Ensure that no other trace is in close proximity to this trace SYNC trace to decrease the stray capacitance on this pin. The stray capacitance affects the performance of the oscillator.

### 11.2 Layout Example

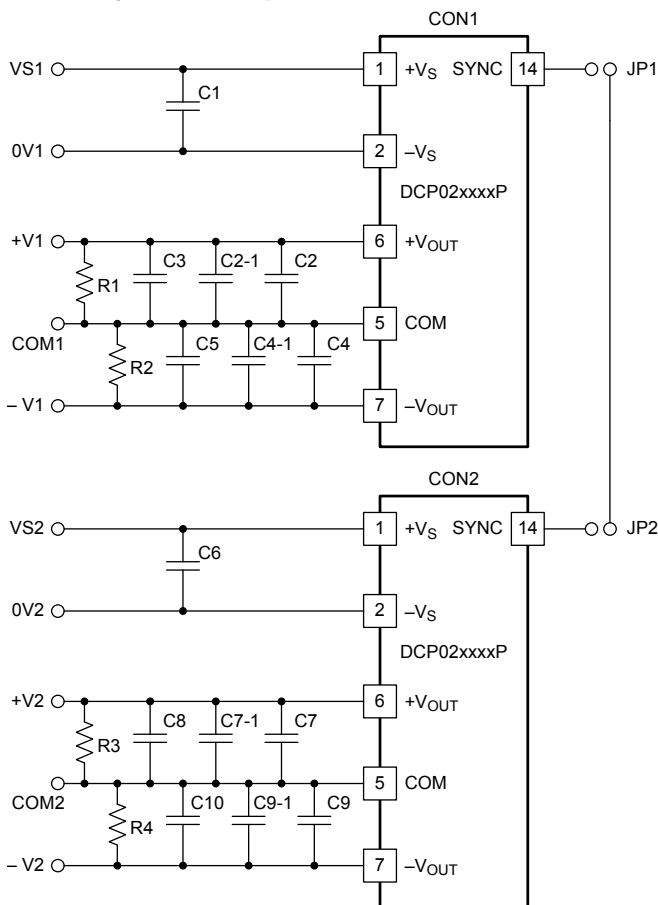

Figure 16. PCB Schematic, P Package

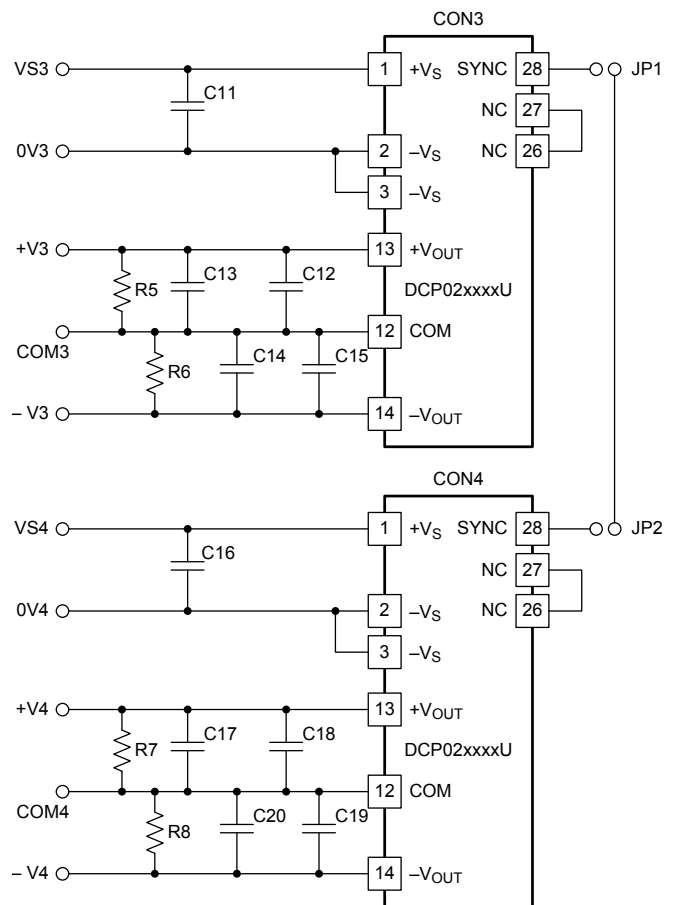

Figure 17. PCB Schematic, U Package

Layout Example (continued)

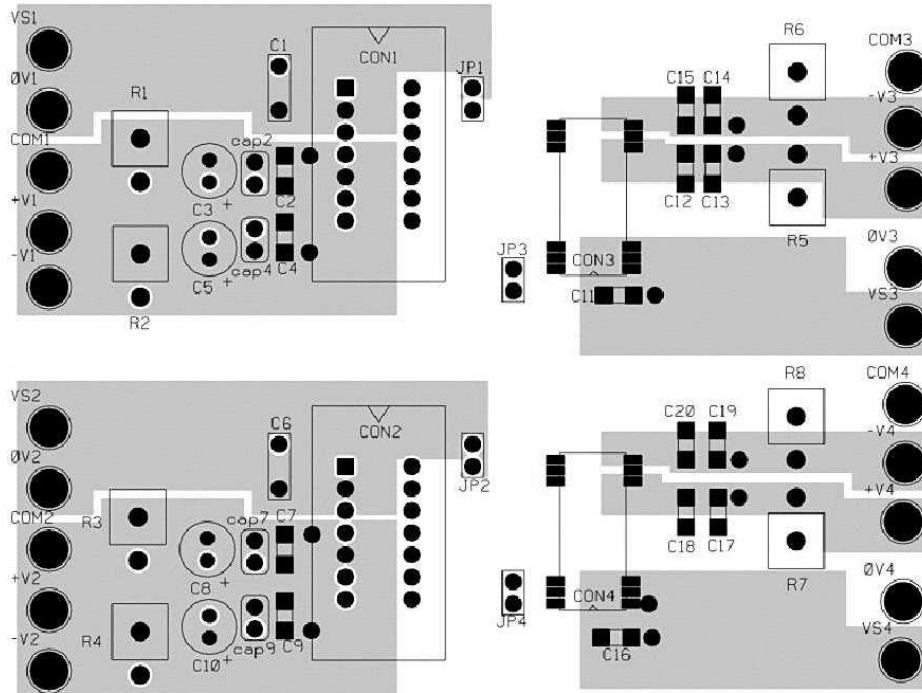

Figure 18. PCB Layout Example, Component-Side View

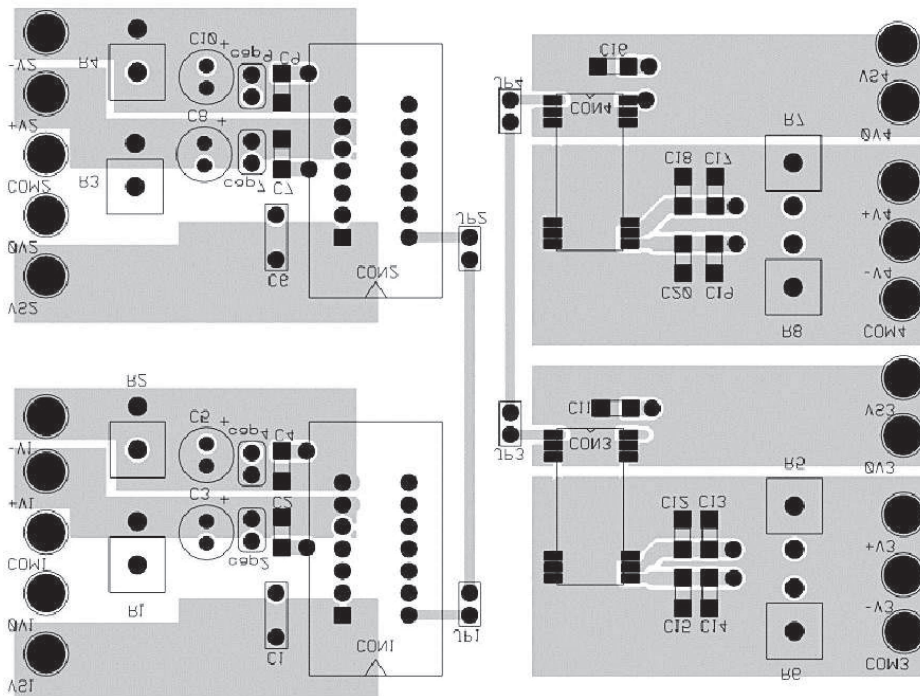

Figure 19. PCB Layout Example, Non-Component-Side View

## 12 Device and Documentation Support

### 12.1 Device Support

#### 12.1.1 Device Nomenclature



**Figure 20. Supplemental Ordering Information**

### 12.2 Documentation Support

#### 12.2.1 Related Documentation

*DC-to-DC Converter Noise Reduction* ([SBVA012](#))

*External Synchronization of the DCP01/02 Series of DC/DC Converters* ([SBAA035](#))

*Optimizing Performance of the DCP01/02 Series of DC/DC Converters* ([SBVA013](#))

#### 12.3 Community Resources

The following links connect to TI community resources. Linked contents are provided "AS IS" by the respective contributors. They do not constitute TI specifications and do not necessarily reflect TI's views; see TI's [Terms of Use](#).

**TI E2E™ Online Community** *TI's Engineer-to-Engineer (E2E) Community*. Created to foster collaboration among engineers. At [e2e.ti.com](http://e2e.ti.com), you can ask questions, share knowledge, explore ideas and help solve problems with fellow engineers.

**Design Support** *TI's Design Support* Quickly find helpful E2E forums along with design support tools and contact information for technical support.

## 12.4 Related Links

The table below lists quick access links. Categories include technical documents, support and community resources, tools and software, and quick access to sample or buy.

Table 2. Related Links

PARTS	PRODUCT FOLDER	SAMPLE & BUY	TECHNICAL DOCUMENTS	TOOLS & SOFTWARE	SUPPORT & COMMUNITY
DCP020503	<a href="#">Click here</a>	<a href="#">Click here</a>	<a href="#">Click here</a>	<a href="#">Click here</a>	<a href="#">Click here</a>
DCP020505	<a href="#">Click here</a>	<a href="#">Click here</a>	<a href="#">Click here</a>	<a href="#">Click here</a>	<a href="#">Click here</a>
DCP020507	<a href="#">Click here</a>	<a href="#">Click here</a>	<a href="#">Click here</a>	<a href="#">Click here</a>	<a href="#">Click here</a>
DCP020509	<a href="#">Click here</a>	<a href="#">Click here</a>	<a href="#">Click here</a>	<a href="#">Click here</a>	<a href="#">Click here</a>
DCP020515D	<a href="#">Click here</a>	<a href="#">Click here</a>	<a href="#">Click here</a>	<a href="#">Click here</a>	<a href="#">Click here</a>
DCP021205	<a href="#">Click here</a>	<a href="#">Click here</a>	<a href="#">Click here</a>	<a href="#">Click here</a>	<a href="#">Click here</a>
DCP021212	<a href="#">Click here</a>	<a href="#">Click here</a>	<a href="#">Click here</a>	<a href="#">Click here</a>	<a href="#">Click here</a>
DCP021212D	<a href="#">Click here</a>	<a href="#">Click here</a>	<a href="#">Click here</a>	<a href="#">Click here</a>	<a href="#">Click here</a>
DCP021515	<a href="#">Click here</a>	<a href="#">Click here</a>	<a href="#">Click here</a>	<a href="#">Click here</a>	<a href="#">Click here</a>
DCP022405	<a href="#">Click here</a>	<a href="#">Click here</a>	<a href="#">Click here</a>	<a href="#">Click here</a>	<a href="#">Click here</a>
DCP022405D	<a href="#">Click here</a>	<a href="#">Click here</a>	<a href="#">Click here</a>	<a href="#">Click here</a>	<a href="#">Click here</a>
DCP022415D	<a href="#">Click here</a>	<a href="#">Click here</a>	<a href="#">Click here</a>	<a href="#">Click here</a>	<a href="#">Click here</a>

## 12.5 Trademarks

E2E is a trademark of Texas Instruments.  
 Underwriters Laboratories, UL are trademarks of UL LLC.  
 All other trademarks are the property of their respective owners.

## 12.6 Electrostatic Discharge Caution



These devices have limited built-in ESD protection. The leads should be shorted together or the device placed in conductive foam during storage or handling to prevent electrostatic damage to the MOS gates.

## 12.7 Glossary

[SLYZ022](#) — *TI Glossary*.

This glossary lists and explains terms, acronyms, and definitions.

## 13 Mechanical, Packaging, and Orderable Information

The following pages include mechanical, packaging, and orderable information. This information is the most current data available for the designated devices. This data is subject to change without notice and revision of this document. For browser-based versions of this data sheet, refer to the left-hand navigation.

**PACKAGING INFORMATION**

Orderable Device	Status (1)	Package Type	Package Drawing	Pins	Package Qty	Eco Plan (2)	Lead/Ball Finish (6)	MSL Peak Temp (3)	Op Temp (°C)	Device Marking (4/5)	Samples
DCP020503P	ACTIVE	PDIP	NVA	7	25	Pb-Free (RoHS)	CU NIPDAU	N / A for Pkg Type	-40 to 85	DCP020503P	<a href="#">Samples</a>
DCP020503U	ACTIVE	SOP	DVB	12	28	Pb-Free (RoHS)	CU NIPDAU	Level-3-260C-168 HR	-40 to 85	DCP020503U	<a href="#">Samples</a>
DCP020505P	ACTIVE	PDIP	NVA	7	25	Pb-Free (RoHS)	CU NIPDAU	N / A for Pkg Type	-40 to 85	DCP020505P	<a href="#">Samples</a>
DCP020505U	ACTIVE	SOP	DVB	12	28	Pb-Free (RoHS)	CU NIPDAU	Level-3-260C-168 HR	-40 to 85	DCP020505U	<a href="#">Samples</a>
DCP020505U/1K	ACTIVE	SOP	DVB	12	1000	Pb-Free (RoHS)	CU NIPDAU	Level-3-260C-168 HR	-40 to 85	DCP020505U	<a href="#">Samples</a>
DCP020505UE4	ACTIVE	SOP	DVB	12	28	Pb-Free (RoHS)	CU NIPDAU	Level-3-260C-168 HR	-40 to 85	DCP020505U	<a href="#">Samples</a>
DCP020507P	ACTIVE	PDIP	NVA	7	25	Pb-Free (RoHS)	CU NIPDAU	N / A for Pkg Type	-40 to 85	DCP020507P	<a href="#">Samples</a>
DCP020507U	ACTIVE	SOP	DVB	12	28	Pb-Free (RoHS)	CU NIPDAU	Level-3-260C-168 HR	-40 to 85	DCP020507U	<a href="#">Samples</a>
DCP020507U/1K	ACTIVE	SOP	DVB	12	1000	Pb-Free (RoHS)	CU NIPDAU	Level-3-260C-168 HR	-40 to 85	DCP020507U	<a href="#">Samples</a>
DCP020509P	ACTIVE	PDIP	NVA	7	25	Pb-Free (RoHS)	CU NIPDAU	N / A for Pkg Type	-40 to 85	DCP020509P	<a href="#">Samples</a>
DCP020509U	ACTIVE	SOP	DVB	12	28	Pb-Free (RoHS)	CU NIPDAU	Level-3-260C-168 HR	-40 to 85	DCP020509U	<a href="#">Samples</a>
DCP020515DP	ACTIVE	PDIP	NVA	7	25	Pb-Free (RoHS)	CU NIPDAU	N / A for Pkg Type	-40 to 85	DCP020515DP	<a href="#">Samples</a>
DCP020515DU	ACTIVE	SOP	DVB	12	28	Pb-Free (RoHS)	CU NIPDAU	Level-3-260C-168 HR	-40 to 85	DCP020515DU	<a href="#">Samples</a>
DCP020515DU/1K	ACTIVE	SOP	DVB	12	1000	Pb-Free (RoHS)	CU NIPDAU	Level-3-260C-168 HR	-40 to 85	DCP020515DU	<a href="#">Samples</a>
DCP021205P	ACTIVE	PDIP	NVA	7	25	Pb-Free (RoHS)	CU NIPDAU	N / A for Pkg Type	-40 to 85	DCP021205P	<a href="#">Samples</a>
DCP021205PE4	ACTIVE	PDIP	NVA	7	25	Pb-Free (RoHS)	CU NIPDAU	N / A for Pkg Type	-40 to 85	DCP021205P	<a href="#">Samples</a>
DCP021205U	ACTIVE	SOP	DVB	12	28	Pb-Free (RoHS)	CU NIPDAU	Level-3-260C-168 HR	-40 to 85	DCP021205U	<a href="#">Samples</a>

Orderable Device	Status (1)	Package Type	Package Drawing	Pins	Package Qty	Eco Plan (2)	Lead/Ball Finish (6)	MSL Peak Temp (3)	Op Temp (°C)	Device Marking (4/5)	Samples
DCP021205U/1K	ACTIVE	SOP	DVB	12	1000	Pb-Free (RoHS)	CU NIPDAU	Level-3-260C-168 HR	-40 to 85	DCP021205U	<a href="#">Samples</a>
DCP021212DP	ACTIVE	PDIP	NVA	7	25	Pb-Free (RoHS)	CU NIPDAU	N / A for Pkg Type	-40 to 85	DCP021212DP	<a href="#">Samples</a>
DCP021212DU	ACTIVE	SOP	DVB	12	28	Pb-Free (RoHS)	CU NIPDAU	Level-3-260C-168 HR	-40 to 85	DCP021212DU	<a href="#">Samples</a>
DCP021212DU/1K	ACTIVE	SOP	DVB	12	1000	Pb-Free (RoHS)	CU NIPDAU	Level-3-260C-168 HR	-40 to 85	DCP021212DU	<a href="#">Samples</a>
DCP021212P	ACTIVE	PDIP	NVA	7	25	Pb-Free (RoHS)	CU NIPDAU	N / A for Pkg Type	-40 to 85	DCP021212P	<a href="#">Samples</a>
DCP021212U	ACTIVE	SOP	DVB	12	28	Pb-Free (RoHS)	CU NIPDAU	Level-3-260C-168 HR	-40 to 85	DCP021212U	<a href="#">Samples</a>
DCP021212U/1K	ACTIVE	SOP	DVB	12	1000	Pb-Free (RoHS)	CU NIPDAU	Level-3-260C-168 HR	-40 to 85	DCP021212U	<a href="#">Samples</a>
DCP021515P	ACTIVE	PDIP	NVA	7	25	Pb-Free (RoHS)	CU NIPDAU	N / A for Pkg Type	-40 to 85	DCP021515P	<a href="#">Samples</a>
DCP021515U	ACTIVE	SOP	DVB	12	28	Pb-Free (RoHS)	CU NIPDAU	Level-3-260C-168 HR	-40 to 85	DCP021515U	<a href="#">Samples</a>
DCP021515U/1K	ACTIVE	SOP	DVB	12	1000	Pb-Free (RoHS)	CU NIPDAU	Level-3-260C-168 HR	-40 to 85	DCP021515U	<a href="#">Samples</a>
DCP022405DP	ACTIVE	PDIP	NVA	7	25	Pb-Free (RoHS)	CU NIPDAU	N / A for Pkg Type	-40 to 85	DCP022405DP	<a href="#">Samples</a>
DCP022405DU	ACTIVE	SOP	DVB	12	28	Pb-Free (RoHS)	CU NIPDAU	Level-3-260C-168 HR	-40 to 85	DCP022405DU	<a href="#">Samples</a>
DCP022405P	ACTIVE	PDIP	NVA	7	25	Pb-Free (RoHS)	CU NIPDAU	N / A for Pkg Type	-40 to 85	DCP022405P	<a href="#">Samples</a>
DCP022405U	ACTIVE	SOP	DVB	12	28	Pb-Free (RoHS)	CU NIPDAU	Level-3-260C-168 HR	-40 to 85	DCP022405U	<a href="#">Samples</a>
DCP022415DP	ACTIVE	PDIP	NVA	7	25	Pb-Free (RoHS)	CU NIPDAU	N / A for Pkg Type	-40 to 85	DCP022415DP	<a href="#">Samples</a>
DCP022415DU	ACTIVE	SOP	DVB	12	28	Pb-Free (RoHS)	CU NIPDAU	Level-3-260C-168 HR	-40 to 85	DCP022415DU	<a href="#">Samples</a>
DCP022415DU/1K	ACTIVE	SOP	DVB	12	1000	Pb-Free (RoHS)	CU NIPDAU	Level-3-260C-168 HR	-40 to 85	DCP022415DU	<a href="#">Samples</a>

(1) The marketing status values are defined as follows:

---

**ACTIVE:** Product device recommended for new designs.

**LIFEBUY:** TI has announced that the device will be discontinued, and a lifetime-buy period is in effect.

**NRND:** Not recommended for new designs. Device is in production to support existing customers, but TI does not recommend using this part in a new design.

**PREVIEW:** Device has been announced but is not in production. Samples may or may not be available.

**OBSOLETE:** TI has discontinued the production of the device.

<sup>(2)</sup> **RoHS:** TI defines "RoHS" to mean semiconductor products that are compliant with the current EU RoHS requirements for all 10 RoHS substances, including the requirement that RoHS substance do not exceed 0.1% by weight in homogeneous materials. Where designed to be soldered at high temperatures, "RoHS" products are suitable for use in specified lead-free processes. TI may reference these types of products as "Pb-Free".

**RoHS Exempt:** TI defines "RoHS Exempt" to mean products that contain lead but are compliant with EU RoHS pursuant to a specific EU RoHS exemption.

**Green:** TI defines "Green" to mean the content of Chlorine (Cl) and Bromine (Br) based flame retardants meet JS709B low halogen requirements of  $\leq 1000$ ppm threshold. Antimony trioxide based flame retardants must also meet the  $\leq 1000$ ppm threshold requirement.

<sup>(3)</sup> **MSL, Peak Temp.** - The Moisture Sensitivity Level rating according to the JEDEC industry standard classifications, and peak solder temperature.

<sup>(4)</sup> There may be additional marking, which relates to the logo, the lot trace code information, or the environmental category on the device.

<sup>(5)</sup> Multiple Device Markings will be inside parentheses. Only one Device Marking contained in parentheses and separated by a "~" will appear on a device. If a line is indented then it is a continuation of the previous line and the two combined represent the entire Device Marking for that device.

<sup>(6)</sup> **Lead/Ball Finish** - Orderable Devices may have multiple material finish options. Finish options are separated by a vertical ruled line. Lead/Ball Finish values may wrap to two lines if the finish value exceeds the maximum column width.

**Important Information and Disclaimer:** The information provided on this page represents TI's knowledge and belief as of the date that it is provided. TI bases its knowledge and belief on information provided by third parties, and makes no representation or warranty as to the accuracy of such information. Efforts are underway to better integrate information from third parties. TI has taken and continues to take reasonable steps to provide representative and accurate information but may not have conducted destructive testing or chemical analysis on incoming materials and chemicals. TI and TI suppliers consider certain information to be proprietary, and thus CAS numbers and other limited information may not be available for release.

In no event shall TI's liability arising out of such information exceed the total purchase price of the TI part(s) at issue in this document sold by TI to Customer on an annual basis.

NVA (R-PDIP-T7/14)

PLASTIC DUAL-IN-LINE

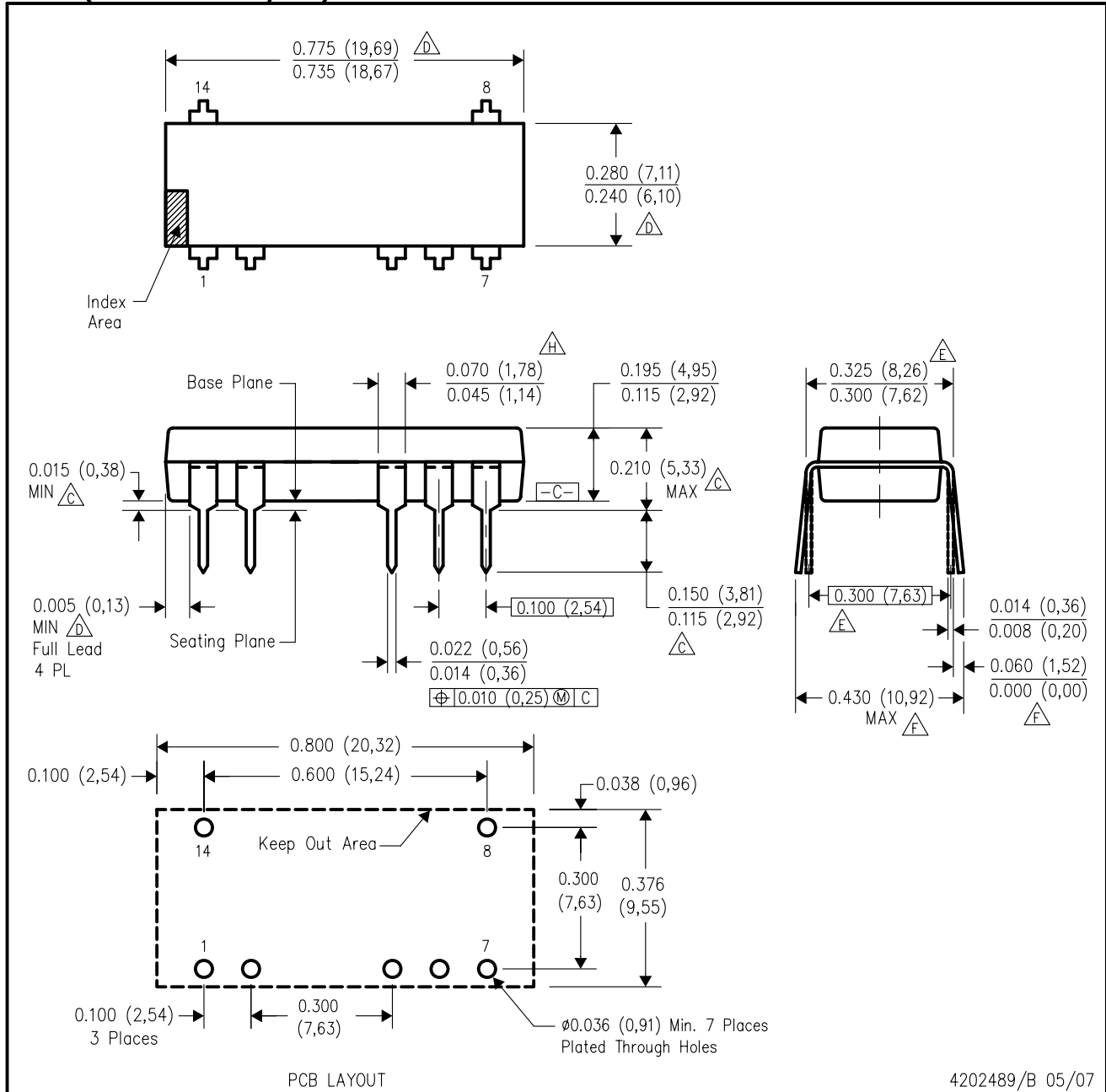

- NOTES:
- A. All linear dimensions are in inches (millimeters).
  - B. This drawing is subject to change without notice.
  - $\triangle A$  Dimensions are measured with the package seated in JEDEC seating plane gauge GS-3.
  - $\triangle D$  Dimensions do not include mold flash or protrusions. Mold flash or protrusions shall not exceed 0.010 (0,25).
  - $\triangle E$  Dimensions measured with the leads constrained to be perpendicular to Datum C.
  - $\triangle F$  Dimensions are measured at the lead tips with the leads unconstrained.
  - G. Pointed or rounded lead tips are preferred to ease insertion.
  - $\triangle H$  Lead shoulder maximum dimension does not include dambar protrusions. Dambar protrusions shall not exceed 0.010 (0,25).
  - I. Distance between leads including dambar protrusions to be 0.005 (0,13) minimum.
  - J. A visual index feature must be located within the cross-hatched area.
  - K. For automatic insertion, any raised irregularity on the top surface (step, mesa, etc.) shall be symmetrical about the lateral and longitudinal package centerlines.
  - L. Falls within JEDEC MS-001-AA.

# DVB0012A



# PACKAGE OUTLINE

## SOP - 2.65 mm max height

PLASTIC SMALL OUTLINE



4222497/A 10/2015

**NOTES:**

1. All linear dimensions are in millimeters. Dimensions in parenthesis are for reference only. Dimensioning and tolerancing per ASME Y14.5M.
2. This drawing is subject to change without notice.
3. This dimension does not include mold flash, protrusions, or gate burrs. Mold flash, protrusions, or gate burrs shall not exceed 0.15 mm per side.
4. Reference JEDEC registration MS-013.

# EXAMPLE BOARD LAYOUT

DVB0012A

SOP - 2.65 mm max height

PLASTIC SMALL OUTLINE



LAND PATTERN EXAMPLE  
SCALE:6X



SOLDER MASK DETAILS

4222497/A 10/2015

NOTES: (continued)

5. Publication IPC-7351 may have alternate designs.
6. Solder mask tolerances between and around signal pads can vary based on board fabrication site.

# EXAMPLE STENCIL DESIGN

DVB0012A

SOP - 2.65 mm max height

PLASTIC SMALL OUTLINE



NOTES: (continued)

7. Laser cutting apertures with trapezoidal walls and rounded corners may offer better paste release. IPC-7525 may have alternate design recommendations.
8. Board assembly site may have different recommendations for stencil design.

## IMPORTANT NOTICE

Texas Instruments Incorporated (TI) reserves the right to make corrections, enhancements, improvements and other changes to its semiconductor products and services per JESD46, latest issue, and to discontinue any product or service per JESD48, latest issue. Buyers should obtain the latest relevant information before placing orders and should verify that such information is current and complete.

TI's published terms of sale for semiconductor products (<http://www.ti.com/sc/docs/stdterms.htm>) apply to the sale of packaged integrated circuit products that TI has qualified and released to market. Additional terms may apply to the use or sale of other types of TI products and services.

Reproduction of significant portions of TI information in TI data sheets is permissible only if reproduction is without alteration and is accompanied by all associated warranties, conditions, limitations, and notices. TI is not responsible or liable for such reproduced documentation. Information of third parties may be subject to additional restrictions. Resale of TI products or services with statements different from or beyond the parameters stated by TI for that product or service voids all express and any implied warranties for the associated TI product or service and is an unfair and deceptive business practice. TI is not responsible or liable for any such statements.

Buyers and others who are developing systems that incorporate TI products (collectively, "Designers") understand and agree that Designers remain responsible for using their independent analysis, evaluation and judgment in designing their applications and that Designers have full and exclusive responsibility to assure the safety of Designers' applications and compliance of their applications (and of all TI products used in or for Designers' applications) with all applicable regulations, laws and other applicable requirements. Designer represents that, with respect to their applications, Designer has all the necessary expertise to create and implement safeguards that (1) anticipate dangerous consequences of failures, (2) monitor failures and their consequences, and (3) lessen the likelihood of failures that might cause harm and take appropriate actions. Designer agrees that prior to using or distributing any applications that include TI products, Designer will thoroughly test such applications and the functionality of such TI products as used in such applications.

TI's provision of technical, application or other design advice, quality characterization, reliability data or other services or information, including, but not limited to, reference designs and materials relating to evaluation modules, (collectively, "TI Resources") are intended to assist designers who are developing applications that incorporate TI products; by downloading, accessing or using TI Resources in any way, Designer (individually or, if Designer is acting on behalf of a company, Designer's company) agrees to use any particular TI Resource solely for this purpose and subject to the terms of this Notice.

TI's provision of TI Resources does not expand or otherwise alter TI's applicable published warranties or warranty disclaimers for TI products, and no additional obligations or liabilities arise from TI providing such TI Resources. TI reserves the right to make corrections, enhancements, improvements and other changes to its TI Resources. TI has not conducted any testing other than that specifically described in the published documentation for a particular TI Resource.

Designer is authorized to use, copy and modify any individual TI Resource only in connection with the development of applications that include the TI product(s) identified in such TI Resource. NO OTHER LICENSE, EXPRESS OR IMPLIED, BY ESTOPPEL OR OTHERWISE TO ANY OTHER TI INTELLECTUAL PROPERTY RIGHT, AND NO LICENSE TO ANY TECHNOLOGY OR INTELLECTUAL PROPERTY RIGHT OF TI OR ANY THIRD PARTY IS GRANTED HEREIN, including but not limited to any patent right, copyright, mask work right, or other intellectual property right relating to any combination, machine, or process in which TI products or services are used. Information regarding or referencing third-party products or services does not constitute a license to use such products or services, or a warranty or endorsement thereof. Use of TI Resources may require a license from a third party under the patents or other intellectual property of the third party, or a license from TI under the patents or other intellectual property of TI.

TI RESOURCES ARE PROVIDED "AS IS" AND WITH ALL FAULTS. TI DISCLAIMS ALL OTHER WARRANTIES OR REPRESENTATIONS, EXPRESS OR IMPLIED, REGARDING RESOURCES OR USE THEREOF, INCLUDING BUT NOT LIMITED TO ACCURACY OR COMPLETENESS, TITLE, ANY EPIDEMIC FAILURE WARRANTY AND ANY IMPLIED WARRANTIES OF MERCHANTABILITY, FITNESS FOR A PARTICULAR PURPOSE, AND NON-INFRINGEMENT OF ANY THIRD PARTY INTELLECTUAL PROPERTY RIGHTS. TI SHALL NOT BE LIABLE FOR AND SHALL NOT DEFEND OR INDEMNIFY DESIGNER AGAINST ANY CLAIM, INCLUDING BUT NOT LIMITED TO ANY INFRINGEMENT CLAIM THAT RELATES TO OR IS BASED ON ANY COMBINATION OF PRODUCTS EVEN IF DESCRIBED IN TI RESOURCES OR OTHERWISE. IN NO EVENT SHALL TI BE LIABLE FOR ANY ACTUAL, DIRECT, SPECIAL, COLLATERAL, INDIRECT, PUNITIVE, INCIDENTAL, CONSEQUENTIAL OR EXEMPLARY DAMAGES IN CONNECTION WITH OR ARISING OUT OF TI RESOURCES OR USE THEREOF, AND REGARDLESS OF WHETHER TI HAS BEEN ADVISED OF THE POSSIBILITY OF SUCH DAMAGES.

Unless TI has explicitly designated an individual product as meeting the requirements of a particular industry standard (e.g., ISO/TS 16949 and ISO 26262), TI is not responsible for any failure to meet such industry standard requirements.

Where TI specifically promotes products as facilitating functional safety or as compliant with industry functional safety standards, such products are intended to help enable customers to design and create their own applications that meet applicable functional safety standards and requirements. Using products in an application does not by itself establish any safety features in the application. Designers must ensure compliance with safety-related requirements and standards applicable to their applications. Designer may not use any TI products in life-critical medical equipment unless authorized officers of the parties have executed a special contract specifically governing such use. Life-critical medical equipment is medical equipment where failure of such equipment would cause serious bodily injury or death (e.g., life support, pacemakers, defibrillators, heart pumps, neurostimulators, and implantables). Such equipment includes, without limitation, all medical devices identified by the U.S. Food and Drug Administration as Class III devices and equivalent classifications outside the U.S.

TI may expressly designate certain products as completing a particular qualification (e.g., Q100, Military Grade, or Enhanced Product). Designers agree that it has the necessary expertise to select the product with the appropriate qualification designation for their applications and that proper product selection is at Designers' own risk. Designers are solely responsible for compliance with all legal and regulatory requirements in connection with such selection.

Designer will fully indemnify TI and its representatives against any damages, costs, losses, and/or liabilities arising out of Designer's non-compliance with the terms and provisions of this Notice.

## Looking for pricing, stock, or lifecycle information?

Click below to explore more details on WIN SOURCE:

 [View DCP022405U](#) on WIN SOURCE

 [Texas Instruments](#) Information

## Optimize Your Supply Chain with WIN SOURCE Solutions

-  Global Sourcing Solution
-  Obsolete Management
-  Cost Control Management
-  Shortage Management
-  Alternative Solution
-  Excess Inventory Management