



**THE DATASHEET OF
CY7C1046D-10VXI**



Features

- Pin- and function-compatible with CY7C1046B
- High speed
 - $t_{AA} = 10 \text{ ns}$
- CMOS for optimum speed and power
- Low active power
 - $I_{CC} = 90 \text{ mA}$ at 10 ns
- Low CMOS standby power
 - $I_{SB2} = 10 \text{ mA}$
- Data retention at 2.0 V
- Automatic power-down when deselected
- TTL-compatible inputs and outputs
- Easy memory expansion with \overline{CE} and \overline{OE} features
- Available in lead-free 400-mil-wide 32-pin SOJ package

Functional Description

The CY7C1046D is a high-performance CMOS static RAM organized as 1M words by 4 bits. Easy memory expansion is

provided by an active LOW Chip Enable (\overline{CE}), an active LOW Output Enable (\overline{OE}), and tri-state drivers. Writing to the device is accomplished by taking Chip Enable (\overline{CE}) and Write Enable (\overline{WE}) inputs LOW. Data on the four I/O pins (I/O_0 through I/O_3) is then written into the location specified on the address pins (A_0 through A_{19}).

Reading from the device is accomplished by taking Chip Enable (\overline{CE}) and Output Enable (\overline{OE}) LOW while forcing Write Enable (\overline{WE}) HIGH. Under these conditions, the contents of the memory location specified by the address pins will appear on the I/O pins.

The four input/output pins (I/O_0 through I/O_3) are placed in a high-impedance state when the device is deselected (\overline{CE} HIGH), the outputs are disabled (\overline{OE} HIGH), or during a write operation (\overline{CE} LOW, and \overline{WE} LOW).

The CY7C1046D is available in a standard 400-mil-wide 32-pin SOJ package with center power and ground (revolutionary) pinout.

The CY7C1046D device is suitable for interfacing with processors that have TTL I/P levels. It is not suitable for processors that require CMOS I/P levels. Please see [Electrical Characteristics on page 4](#) for more details and suggested alternatives.

For a complete list of related documentation, [click here](#).

Logic Block Diagram

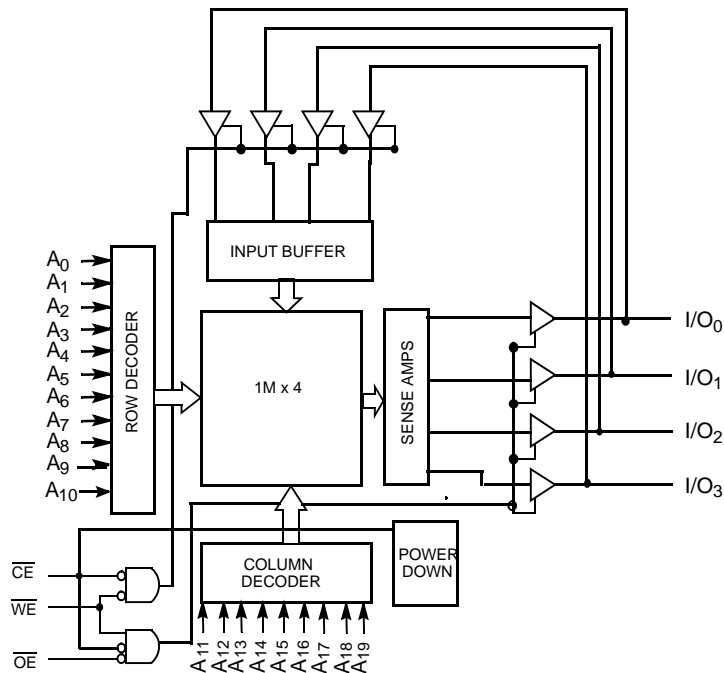

Contents

Selection Guide	3	Ordering Information	12
Pin Configuration	3	Ordering Code Definitions	12
Maximum Ratings	4	Package Diagrams	13
Operating Range	4	Acronyms	14
Electrical Characteristics	4	Document Conventions	14
Capacitance	5	Units of Measure	14
Thermal Resistance	5	Document History Page	15
AC Test Loads and Waveforms	5	Sales, Solutions, and Legal Information	16
Data Retention Characteristics	6	Worldwide Sales and Design Support	16
Data Retention Waveform	6	Products	16
Switching Characteristics	7	PSoC® Solutions	16
Switching Waveforms	8	Cypress Developer Community	16
Truth Table	11	Technical Support	16

Selection Guide

Description	-10	Unit
Maximum Access Time	10	ns
Maximum Operating Current	90	mA
Maximum CMOS Standby Current (mA)	10	mA

Pin Configuration

Figure 1. 32-pin SOJ pinout (Top View)

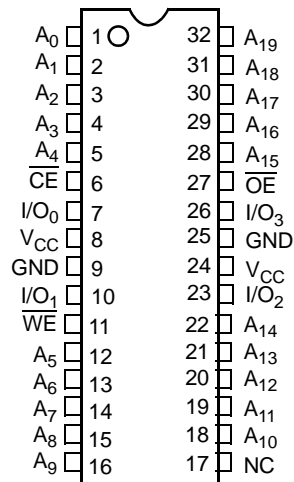

Maximum Ratings

Exceeding maximum ratings may shorten the useful life of the device. User guidelines are not tested.

Storage temperature -65 °C to +150 °C
 Ambient temperature with power applied -55 °C to +125 °C
 Supply voltage on V_{CC} to relative GND ^[1] -0.5 V to +6.0 V
 DC voltage applied to outputs in high Z state ^[1] -0.5 V to $V_{CC} + 0.5$ V

DC input voltage ^[1] -0.5 V to $V_{CC} + 0.5$ V
 Current into outputs (LOW) 20 mA
 Static discharge voltage (per MIL-STD-883, method 3015) > 2001 V
 Latch up current > 200 mA

Operating Range

Range	Ambient Temperature	V_{CC}
Industrial	-40 °C to +85 °C	4.5 V–5.5 V

Electrical Characteristics

Over the Operating Range

Parameter	Description	Test Conditions	-10		Unit	
			Min	Max		
V_{OH}	Output HIGH voltage	$V_{CC} = \text{Min}, I_{OH} = -4.0 \text{ mA}$	2.4	–	V	
		$V_{CC} = \text{Max}, I_{OH} = -0.1 \text{ mA}$	–	3.4 ^[2]		
V_{OL}	Output LOW voltage	$V_{CC} = \text{Min}, I_{OL} = 8.0 \text{ mA}$	–	0.4	V	
V_{IH}	Input HIGH voltage		2.0	$V_{CC} + 0.5$	V	
V_{IL}	Input LOW voltage ^[1]		-0.5	0.8	V	
I_{IX}	Input leakage current	$GND \leq V_{IN} \leq V_{CC}$	-1	+1	μA	
I_{OZ}	Output leakage current	$GND \leq V_{OUT} \leq V_{CC}$, output disabled	-1	+1	μA	
I_{CC}	V_{CC} operating supply current	$V_{CC} = \text{Max}, f = f_{\text{MAX}} = 1/t_{RC}$	100 MHz	–	90	mA
			83 MHz	–	80	
			66 MHz	–	70	
			40 MHz	–	60	
I_{SB1}	Automatic CE Power-Down Current – TTL inputs	$\text{Max } V_{CC}, \overline{CE} \geq V_{IH}, V_{IN} \geq V_{IH}$ or $V_{IN} \leq V_{IL}, f = f_{\text{MAX}}$	–	20	mA	
I_{SB2}	Automatic CE Power-Down Current – CMOS inputs	$\text{Max } V_{CC}, \overline{CE} \geq V_{CC} - 0.3 \text{ V}, V_{IN} \geq V_{CC} - 0.3 \text{ V},$ or $V_{IN} \leq 0.3 \text{ V}, f = 0$	–	10	mA	

Notes

- $V_{IL}(\text{min}) = -2.0 \text{ V}$ and $V_{IH}(\text{max}) = V_{CC} + 2 \text{ V}$ for pulse durations of less than 20 ns.
- Please note that the maximum V_{OH} limit does not exceed minimum CMOS V_{IH} of 3.5V. If you are interfacing this SRAM with 5V legacy processors that require a minimum V_{IH} of 3.5V, please refer to Application Note [AN6081](#) for technical details and options you may consider.

Capacitance

Parameter ^[3]	Description	Test Conditions	Max	Unit
C _{IN}	Input capacitance	T _A = 25 °C, f = 1 MHz, V _{CC} = 5.0 V	8	pF
C _{OUT}	I/O capacitance		8	pF

Thermal Resistance

Parameter ^[3]	Description	Test Conditions	SOJ Package	Unit
Θ _{JA}	Thermal resistance (junction to ambient)	Still Air, soldered on a 3 × 4.5 inch, four-layer printed circuit board	53.44	°C/W
Θ _{JC}	Thermal resistance (junction to case)		38.25	°C/W

AC Test Loads and Waveforms

Figure 2. AC Test Loads and Waveforms ^[4]

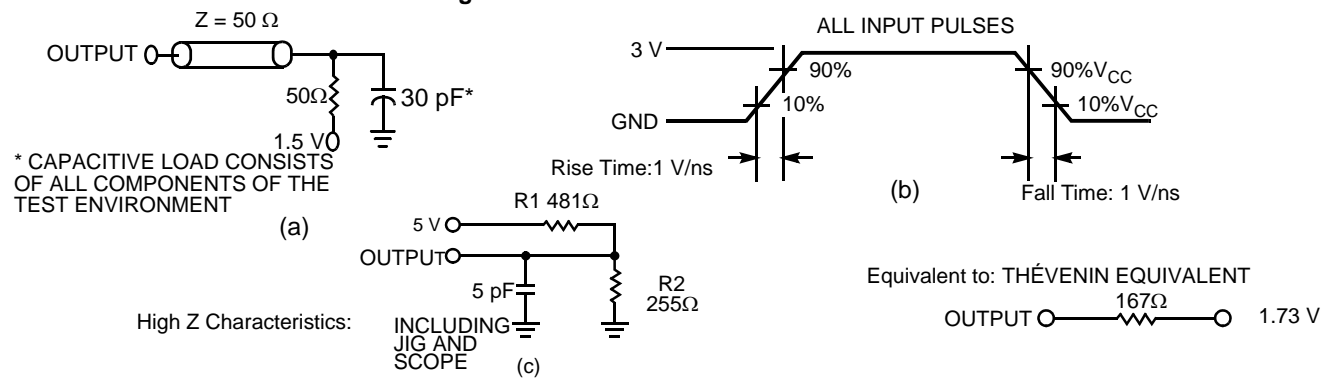

Notes

3. Tested initially and after any design or process changes that may affect these parameters.
4. AC characteristics (except high Z) are tested using the load conditions shown in (a). High Z characteristics are tested for all speeds using the test load shown in (c).

Data Retention Characteristics

Over the Operating Range

Parameter	Description	Conditions ^[5]	Min	Max	Unit
V_{DR}	V_{CC} for data retention		2.0	–	V
I_{CCDR}	Data retention current	$V_{CC} = V_{DR} = 2.0\text{ V}$, $CE \geq V_{CC} - 0.3\text{ V}$, $V_{IN} \geq V_{CC} - 0.3\text{ V}$ or $V_{IN} \leq 0.3\text{ V}$	–	10	mA
$t_{CDR}^{[6]}$	Chip deselect to data retention time		0	–	ns
$t_R^{[7]}$	Operation recovery time		t_{RC}	–	ns

Data Retention Waveform

Figure 3. Data Retention Waveform

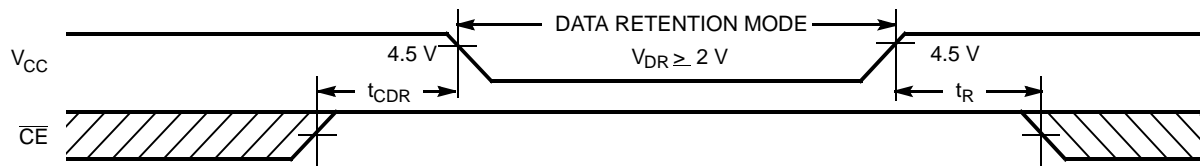

Notes

- No inputs may exceed $V_{CC} + 0.3\text{ V}$.
- Tested initially and after any design or process changes that may affect these parameters.
- Full device operation requires linear V_{CC} ramp from V_{DR} to $V_{CC(\min)} \geq 50\ \mu\text{s}$ or stable at $V_{CC(\min)} \geq 50\ \mu\text{s}$.

Switching Characteristics

Over the Operating Range

Parameter ^[8]	Description	7C1046D-10		Unit
		Min	Max	
Read Cycle				
t_{power}	V_{CC} (typical) to the first access ^[9]	100	–	μs
t_{RC}	Read cycle time	10	–	ns
t_{AA}	Address to data valid	–	10	ns
t_{OHA}	Data hold from address change	3	–	ns
t_{ACE}	$\overline{\text{CE}}$ LOW to data valid	–	10	ns
t_{DOE}	$\overline{\text{OE}}$ LOW to data valid	–	5	ns
t_{LZOE}	$\overline{\text{OE}}$ LOW to low $Z^{[11]}$	0	–	ns
t_{HZOE}	$\overline{\text{OE}}$ HIGH to high $Z^{[10, 11]}$	–	5	ns
t_{LZCE}	$\overline{\text{CE}}$ LOW to low $Z^{[11]}$	3	–	ns
t_{HZCE}	$\overline{\text{CE}}$ HIGH to high $Z^{[10, 11]}$	–	5	ns
t_{PU}	$\overline{\text{CE}}$ LOW to power-up	0	–	ns
t_{PD}	$\overline{\text{CE}}$ HIGH to power-down	–	10	ns
Write Cycle^[12, 13]				
t_{WC}	Write cycle time	10	–	ns
t_{SCE}	$\overline{\text{CE}}$ LOW to write end	7	–	ns
t_{AW}	Address set-up to write end	7	–	ns
t_{HA}	Address hold from write end	0	–	ns
t_{SA}	Address set-up to write start	0	–	ns
t_{PWE}	$\overline{\text{WE}}$ pulse width	7	–	ns
t_{SD}	Data set-up to write end	6	–	ns
t_{HD}	Data hold from write end	0	–	ns
t_{LZWE}	$\overline{\text{WE}}$ HIGH to low $Z^{[11]}$	3	–	ns
t_{HZWE}	$\overline{\text{WE}}$ LOW to high $Z^{[10, 11]}$	–	5	ns

Notes

8. Test conditions assume signal transition time of 3 ns or less, timing reference levels of 1.5 V, input pulse levels of 0 to 3.0 V.
9. t_{POWER} gives the minimum amount of time that the power supply should be at stable, typical V_{CC} values until the first memory access can be performed.
10. t_{HZOE} , t_{HZCE} , and t_{HZWE} are specified with a load capacitance of 5 pF as in part (b) of AC Test Loads. Transition is measured when the outputs enter a high impedance state.
11. At any given temperature and voltage condition, t_{HZCE} is less than t_{LZCE} , t_{HZOE} is less than t_{LZOE} , and t_{HZWE} is less than t_{LZWE} for any given device.
12. The internal write time of the memory is defined by the overlap of $\overline{\text{CE}}$ LOW, and $\overline{\text{WE}}$ LOW. $\overline{\text{CE}}$ and $\overline{\text{WE}}$ must be LOW to initiate a write, and the transition of either of these signals can terminate the write. The input data set-up and hold timing should be referenced to the leading edge of the signal that terminates the write.
13. The minimum write cycle time for Write Cycle no. 3 ($\overline{\text{WE}}$ controlled, $\overline{\text{OE}}$ LOW) is the sum of t_{HZWE} and t_{SD} .

Switching Waveforms

Figure 4. Read Cycle No. 1 [14, 15]

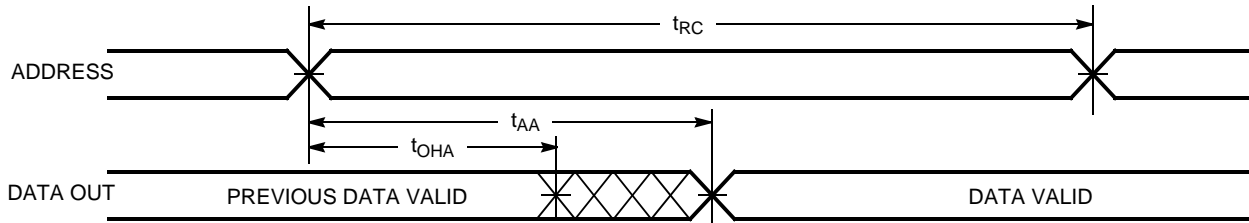
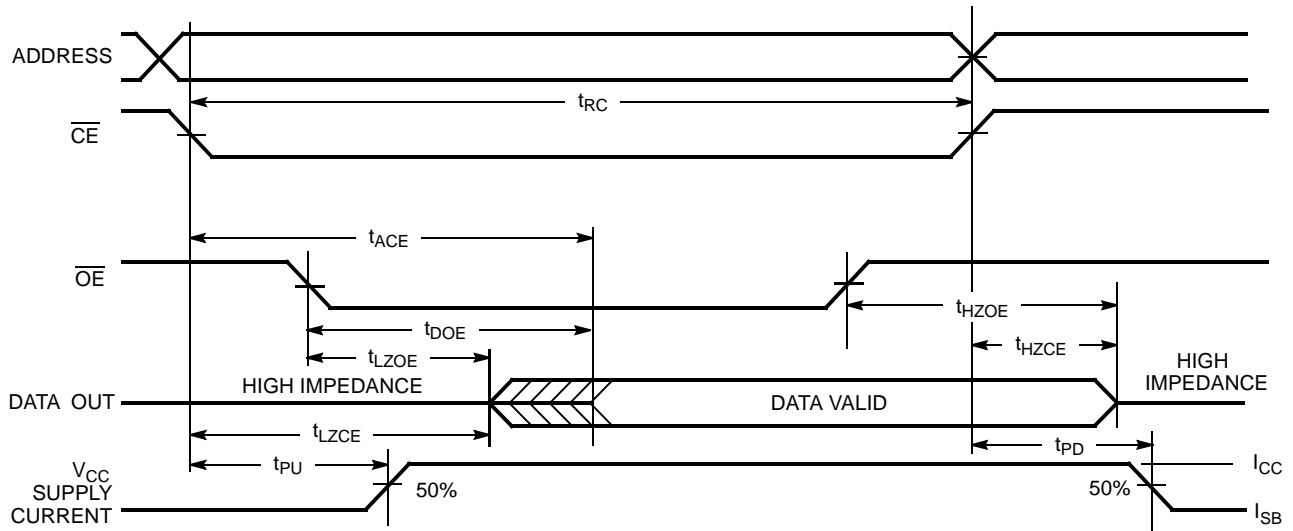

Figure 5. Read Cycle No. 2 (\overline{OE} Controlled) [15, 16]



Notes

- 14. Device is continuously selected. \overline{OE} , $\overline{CE} = V_{IL}$.
- 15. WE is HIGH for read cycle.
- 16. Address valid prior to or coincident with \overline{CE} transition LOW.

Switching Waveforms (continued)

Figure 6. Write Cycle No. 1 ($\overline{\text{CE}}$ Controlled) [17, 18]

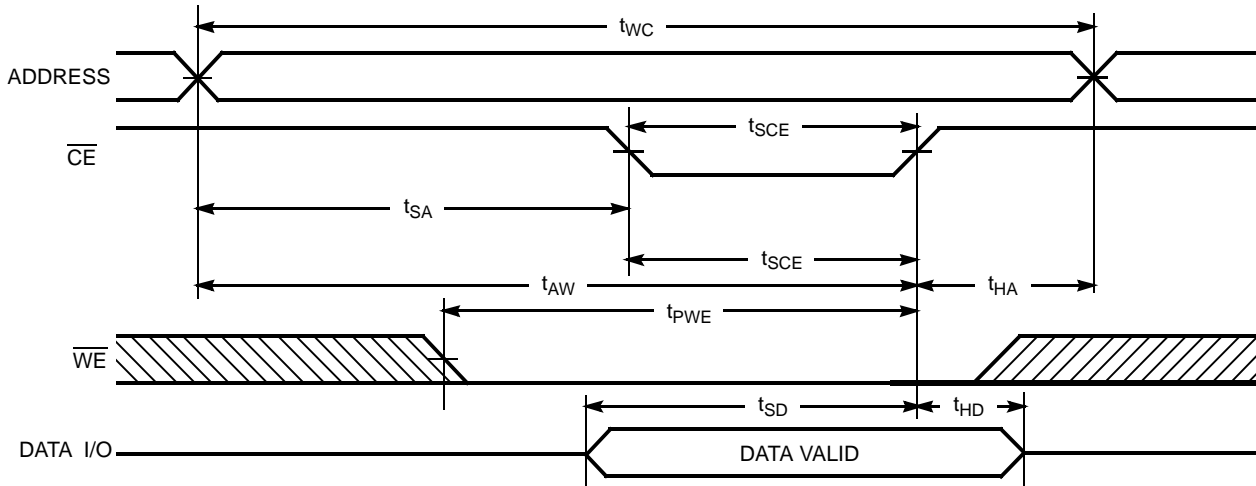
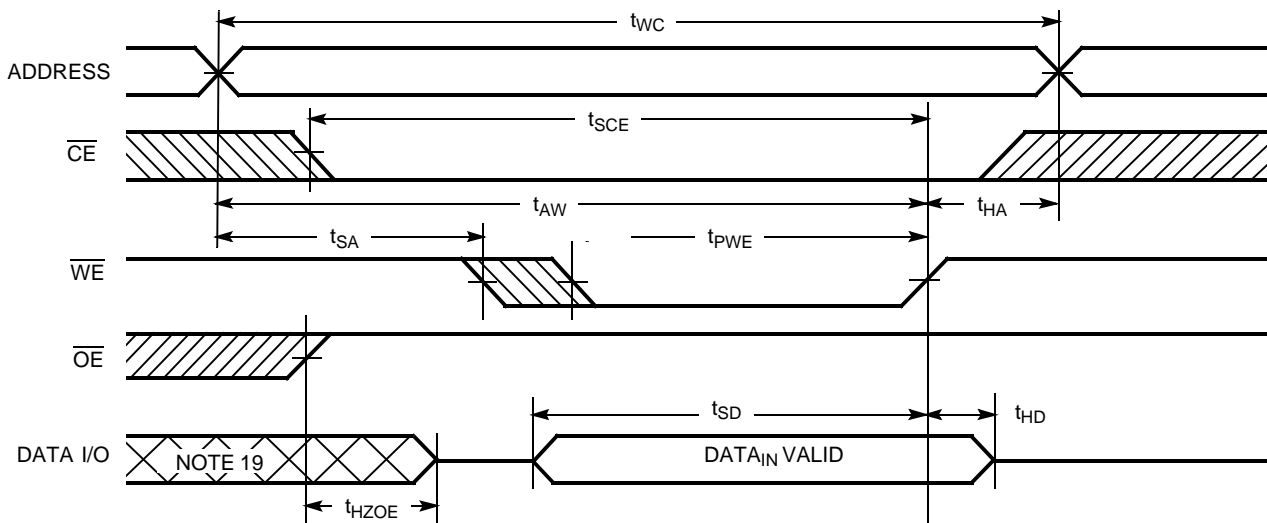

Figure 7. Write Cycle No. 2 ($\overline{\text{WE}}$ Controlled, $\overline{\text{OE}}$ HIGH During Write) [17, 18]



Notes

- 17. Data I/O is high impedance if $\overline{\text{OE}} = V_{IH}$.
- 18. If $\overline{\text{CE}}$ goes HIGH simultaneously with $\overline{\text{WE}}$ going HIGH, the output remains in a high-impedance state.
- 19. During this period the I/Os are in the output state and input signals should not be applied.

Switching Waveforms (continued)

Figure 8. Write Cycle No. 3 (\overline{WE} Controlled, \overline{OE} LOW) [20]

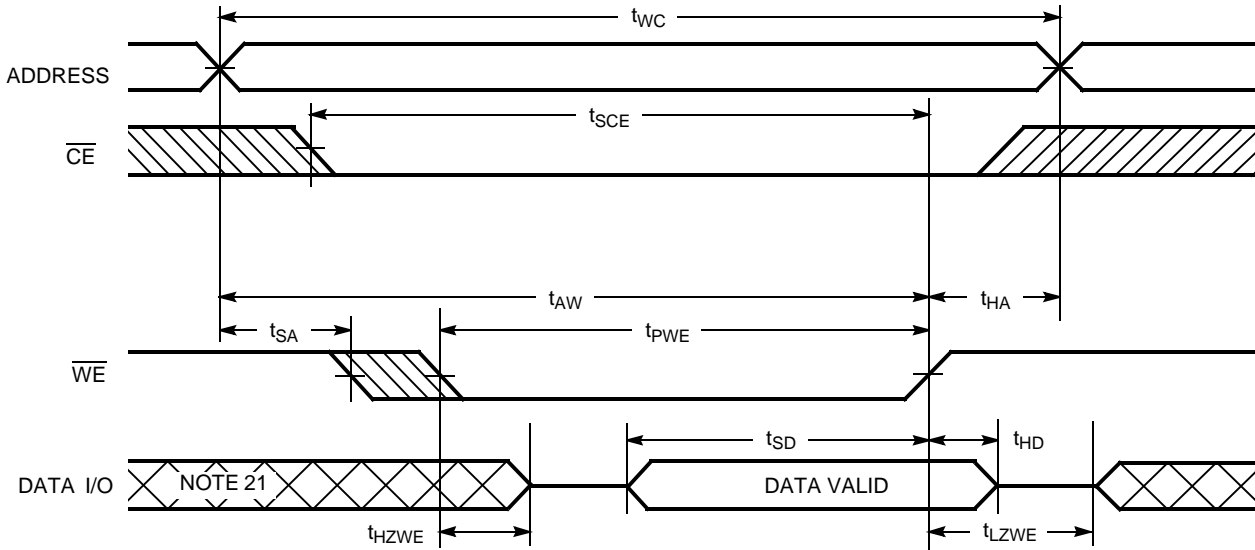

Notes

- 20. If \overline{CE} goes HIGH simultaneously with \overline{WE} going HIGH, the output remains in a high-impedance state.
- 21. During this period the I/Os are in the output state and input signals should not be applied.

Truth Table

$\overline{\text{CE}}$	$\overline{\text{OE}}$	$\overline{\text{WE}}$	I/O ₀ –I/O ₃	Mode	Power
H	X	X	High Z	Power-down	Standby (I _{SB})
L	L	H	Data Out	Read	Active (I _{CC})
L	X	L	Data In	Write	Active (I _{CC})
L	H	H	High Z	Selected, outputs disabled	Active (I _{CC})

Ordering Information

Speed (ns)	Ordering Code	Package Diagram	Package Type	Operating Range
10	CY7C1046D-10VXI	51-85033	32-pin (400-Mil) Molded SOJ (Pb-free)	Industrial

Please contact your local Cypress sales representative for availability of these parts.

Ordering Code Definitions

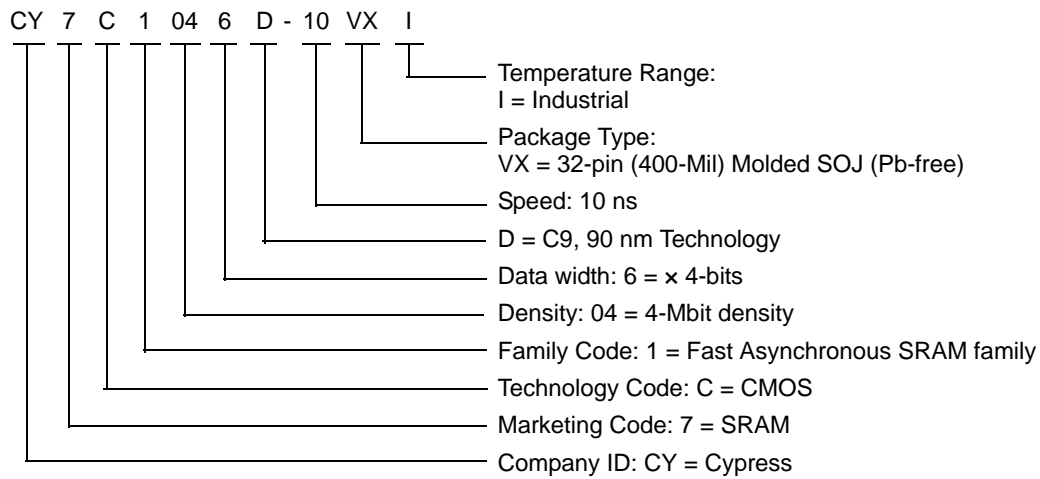

Package Diagrams

Figure 9. 32-pin SOJ (400 Mils) V32.4 (Molded SOJ V33) Package Outline, 51-85033

32 Lead (400 MIL) Molded SOJ V33

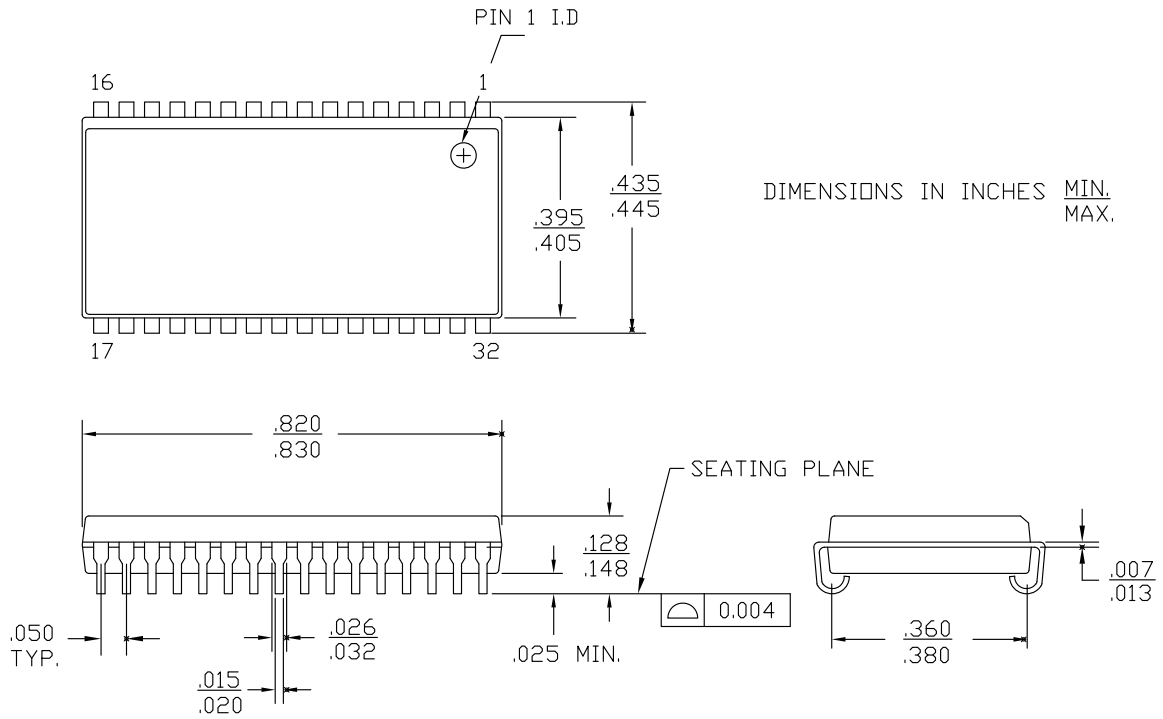

51-85033 *E

Acronyms

Acronym	Description
CMOS	Complementary Metal Oxide Semiconductor
\overline{CE}	Chip Enable
I/O	Input/Output
\overline{OE}	Output Enable
SOJ	Small-Outline J-leaded
SRAM	Static Random Access Memory
TTL	Transistor-Transistor Logic
\overline{WE}	Write Enable

Document Conventions

Units of Measure

Symbol	Unit of Measure
°C	degree Celsius
MHz	megahertz
μs	microsecond
μA	microampere
mA	milliampere
ns	nanosecond
%	percent
pF	picofarad
V	volt
W	watt

Document History Page

Document Title: CY7C1046D, 4-Mbit (1 M × 4) Static RAM Document Number: 38-05705				
Rev.	ECN No.	Issue Date	Orig. of Change	Description of Change
**	307613	See ECN	RKF	New data sheet.
*A	399070	See ECN	NXR	<p>Changed from Advance to Preliminary</p> <p>Changed address of Cypress Semiconductor Corporation on Page# 1 from "3901 North First Street" to "198 Champion Court"</p> <p>Removed -20 speed bin</p> <p>Removed L-Version</p> <p>Redefined I_{CC} values for Com'l and Ind'l temperature ranges</p> <p>I_{CC} (Com'l): Changed from 70 and 55 mA to 75 and 70 mA for 12 and 15 ns speed bins respectively</p> <p>I_{CC} (Ind'l): Changed from 80, 70 and 55 mA to 90, 85 and 80 mA for 10, 12 and 15 ns speed bins respectively</p> <p>Added Industrial Operating Range</p> <p>Changed reference voltage level for measurement of Hi-Z parameters from ±500 mV to ±200 mV</p> <p>Changed V_{CC} to 3 V in the Input pulse waveform at the AC Test Loads and Waveforms on page # 3</p> <p>Changed t_{SCE} from 8 to 7 ns for -10 speed bin</p> <p>Added Truth Table</p> <p>Added 10 ns parts in the Ordering Information table</p> <p>Changed part names from V33 to V324 in the Ordering Information Table</p> <p>Shaded Ordering Information Table</p>
*B	459072	See ECN	NXR	<p>Converted from Preliminary to Final.</p> <p>Removed -12 and -15 Speed bins</p> <p>Removed Commercial Operating Range product information.</p> <p>Changed Maximum Rating for supply voltage from 7V to 6V</p> <p>Changed the Capacitance value of input pins and I/O pins from 6 pF to 8 pF</p> <p>Updated the Thermal Resistance table.</p> <p>Changed t_{HZWE} from 6 ns to 5 ns</p> <p>Added footnote #4 and 11</p> <p>Updated footnote #7 on High-Z parameter measurement</p> <p>Updated the Ordering Information and replaced Package Name column with Package Diagram in the Ordering Information table.</p>
*C	3059162	10/14/2010	PRAS	<p>Added Ordering Code Definitions.</p> <p>Updated Package Diagrams.</p>
*D	3098812	12/01/2010	PRAS	<p>Added Acronyms and Units of Measure.</p> <p>Minor edits and updated in new template.</p>
*E	3446913	11/24/2011	TAVA	<p>Removed Note referring to SRAM System Guidelines application note on page 1.</p> <p>Updated test conditions for IIX parameter.</p>
*F	4039540	06/25/2013	MEMJ	<p>Updated Functional Description.</p> <p>Updated Electrical Characteristics:</p> <p>Added one more Test Condition "V_{CC} = Max, I_{OH} = -0.1 mA" for V_{OH} parameter and added maximum value corresponding to that Test Condition.</p> <p>Added Note 2 and referred the same note in maximum value for V_{OH} parameter corresponding to Test Condition "V_{CC} = Max, I_{OH} = -0.1 mA".</p>
*G	4574311	11/20/2014	MEMJ	<p>Added related documentation hyperlink in page 1.</p> <p>Updated Figure 9 in Package Diagrams (spec 51-85033 *D to *E).</p>

Sales, Solutions, and Legal Information

Worldwide Sales and Design Support

Cypress maintains a worldwide network of offices, solution centers, manufacturer's representatives, and distributors. To find the office closest to you, visit us at [Cypress Locations](#).

Products

Automotive	cypress.com/go/automotive
Clocks & Buffers	cypress.com/go/clocks
Interface	cypress.com/go/interface
Lighting & Power Control	cypress.com/go/powerpsoc cypress.com/go/plc
Memory	cypress.com/go/memory
PSoC	cypress.com/go/psoc
Touch Sensing	cypress.com/go/touch
USB Controllers	cypress.com/go/USB
Wireless/RF	cypress.com/go/wireless

PSoC[®] Solutions

[psoc.cypress.com/solutions](#)
[PSoC 1](#) | [PSoC 3](#) | [PSoC 4](#) | [PSoC 5LP](#)

Cypress Developer Community

[Community](#) | [Forums](#) | [Blogs](#) | [Video](#) | [Training](#)

Technical Support

[cypress.com/go/support](#)

© Cypress Semiconductor Corporation, 2005-2014. The information contained herein is subject to change without notice. Cypress Semiconductor Corporation assumes no responsibility for the use of any circuitry other than circuitry embodied in a Cypress product. Nor does it convey or imply any license under patent or other rights. Cypress products are not warranted nor intended to be used for medical, life support, life saving, critical control or safety applications, unless pursuant to an express written agreement with Cypress. Furthermore, Cypress does not authorize its products for use as critical components in life-support systems where a malfunction or failure may reasonably be expected to result in significant injury to the user. The inclusion of Cypress products in life-support systems application implies that the manufacturer assumes all risk of such use and in doing so indemnifies Cypress against all charges.



Any Source Code (software and/or firmware) is owned by Cypress Semiconductor Corporation (Cypress) and is protected by and subject to worldwide patent protection (United States and foreign), United States copyright laws and international treaty provisions. Cypress hereby grants to licensee a personal, non-exclusive, non-transferable license to copy, use, modify, create derivative works of, and compile the Cypress Source Code and derivative works for the sole purpose of creating custom software and or firmware in support of licensee product to be used only in conjunction with a Cypress integrated circuit as specified in the applicable agreement. Any reproduction, modification, translation, compilation, or representation of this Source Code except as specified above is prohibited without the express written permission of Cypress.

Disclaimer: CYPRESS MAKES NO WARRANTY OF ANY KIND, EXPRESS OR IMPLIED, WITH REGARD TO THIS MATERIAL, INCLUDING, BUT NOT LIMITED TO, THE IMPLIED WARRANTIES OF MERCHANTABILITY AND FITNESS FOR A PARTICULAR PURPOSE. Cypress reserves the right to make changes without further notice to the materials described herein. Cypress does not assume any liability arising out of the application or use of any product or circuit described herein. Cypress does not authorize its products for use as critical components in life-support systems where a malfunction or failure may reasonably be expected to result in significant injury to the user. The inclusion of Cypress' product in a life-support systems application implies that the manufacturer assumes all risk of such use and in doing so indemnifies Cypress against all charges.

Use may be limited by and subject to the applicable Cypress software license agreement.

Looking for pricing, stock, or lifecycle information?

Click below to explore more details on WIN SOURCE:

-  [View CY7C1046D-10VXI on WIN SOURCE](#)
-  [Cypress Semiconductor Corp Information](#)

Optimize Your Supply Chain with WIN SOURCE Solutions

-  Global Sourcing Solution
-  Obsolete Management
-  Cost Control Management
-  Shortage Management
-  Alternative Solution
-  Excess Inventory Management